

Vehicle Standards Bulletin 14

**NATIONAL CODE OF PRACTICE
for
LIGHT VEHICLE CONSTRUCTION
and
MODIFICATION**

**SECTION LK
SEATING and OCCUPANT PROTECTION**

VERSION 2.0 JANUARY 2011

Vehicle Standards Bulletin 14

National Code of Practice for Light Vehicle Construction and Modification (VSB 14)

Important Information for Users

Users of VSB 14 need to be aware that this document needs to be used in conjunction with the appropriate administrative requirements of the jurisdiction in which they wish to either register a vehicle or to obtain approval for a modification for an already registered vehicle. *Administrative requirements* include, amongst other things, processes for vehicle registration, obtaining exemptions, obtaining modification approvals, vehicle inspections, preparation and submission of reports and the payment of appropriate fees and charges.

If unsure of any of the requirements specified in VSB 14, or if more information is needed for any other issues concerning the administrative requirements, users should contact their relevant Registration Authority **prior** to commencing any work.

While VSB 14 provides advice on the construction of Individually Constructed Vehicles (ICVs) and the execution of modifications, it is not to be taken to be a design manual. Determination of component strength, performance, suitability and functionality must be either calculated or determined on a case by case basis by suitably qualified personnel experienced in each matter under consideration.

Users of VSB 14 also need to ensure that they refer to the most recent version of the relevant Section/s when working on a project. The version is identified by the version number and date on the face page of each Section. The version and date is also located in the footer of each page in each Section. On the website the version number is specified in the Section file name for easy identification.

If a project is taking a long time to complete, check the currency of the version you are using.

Users must be familiar with the provisions stated in the Preface and Introduction. These two Sections provide the necessary background information to assist users in understanding how VSB 14 is administered by Registration Authorities across Australia, on how it is structured, and the meaning of the types of modification codes specified in VSB 14. If not already done so, users should download them for study and reference.

Understanding these requirements is important to ensure that the correct processes are followed thereby reducing the likelihood of having work rejected by Registration Authorities.

Many of the Sections refer to other Sections within VSB 14 for further information or additional requirements. Users must read and apply all relevant Sections.

If in doubt about any issue concerning or contained in VSB 14, users should seek clarification from the appropriate State or Territory Registration Authority.

Please do not contact Vehicle Safety Standards (VSS) of the Australian Government Department of Infrastructure and Transport in Canberra about VSB 14. VSS provides the website as a service only.

Document Amendments by Version

Edition

Version 2

Published 1 January 2011

Amendments

Code LK8 *Roll-bar and Roll-cage* Installation has been totally revised to include three new codes.

Code LK8 now covers one-off roll-bars and roll-cages, LK9 covers the design of commercially produced roll-bars, roll-cages and ROPS. Code LK10 covers the installation of devices certified under Code LK9.

All mandatory padding must meet the padding specifications detailed in Appendix B *Foam Padding for Occupant Protection* in Section LZ *Appendices*.

This document has also a number of editorial amendments that have had no affect on its technical content.

CONTENTS

		Page
1	Scope	5
1.1	Basic Modifications Not Requiring Certification	5
1.2	Modifications Requiring Certification Under LK Codes	5
2	General Requirements	5
2.1	Fabrication	6
2.2	Laden Mass Limits	7
3	Australian Design Rules	7
4	Basic Modifications Without Certification	8
4.1	Optional Seats	8
5	Certified Modifications (LK Codes)	9
LK1	Seat and Seatbelt Installation/Removal	10
	Checklist	19
LK2	Seat and Anchorage Certification	22
	Checklist	26
LK3 to LK5	Not in use	
LK6	Child Restraint Anchorage Installation	28
	Checklist	38
LK7	Not in use	
LK8	Construction and Installation of One-Off Roll-bars and Roll-cages by Individuals	39
	Checklist	51
LK9	Design and Manufacture of Commercial Aftermarket Roll-bars, Roll-cages and Other Types of ROPS	53
	Checklist	59
LK10	Installation of Aftermarket Roll-bars, Roll-cages and ROPS	62
	Checklist	66
	Appendix LK1 Supporting Information for Codes LK8, LK9 and LK10	69
	Table LK9 Applicability Table for Codes LK8, LK9 and LK10	71

1 SCOPE

This Section outlines the minimum design, fabrication, and installation requirements for the installation of seats, seatbelts, anchorage points for seats and seatbelts, child restraint anchorage points and roll-over protection devices.

Section LK does not cover the installation of externally mounted *roll-bars*, *roll-cages* or other types of *roll-over protective structures* (ROPS).

Section LK does not apply to ADR Category L-Group vehicles and motor cycles.

1.1 BASIC MODIFICATIONS NOT REQUIRING CERTIFICATION

Fitting a manufacturer's optional seating configuration to the particular make/model.

1.2 MODIFICATIONS REQUIRING CERTIFICATION UNDER LK CODES

The following modifications require certification under the LK Codes:

- Fitting complying seating to complying seat anchorages;
- Fitting complying seatbelts to complying seatbelt anchorages;
- Fitting complying child restraint anchorages;
- Reduction in Seating Capacity; and
- Fitting roll-bars, roll-cages and other types of ROPS.

2 GENERAL REQUIREMENTS

This sub-section applies to all light vehicles and must be read and applied in conjunction with all the LK Codes applicable to the proposed modifications.

Modified vehicles must continue to comply with the Australian Design Rules (ADRs) to which they were originally constructed, except as allowed for in the Australian Vehicle Standards Rules (AVSR). These modified vehicles must also comply with the applicable in-service requirements of the AVSR.

Modified pre-ADR vehicles must continue to comply with the AVSR.

Compliance with the AVSR also means compliance with the equivalent regulations of a State or Territory of Australia.

Seats and seatbelts play a critical role in occupant protection and personal comfort. The seat and seatbelt can be subjected to substantial forces in a crash. It is important therefore that each device is carefully designed, constructed and installed to ensure that adequate occupant protection is provided.

Passenger vehicles generally provide a higher level of safety than goods carrying vehicles. Where additional seats fitted to a new vehicle prior to first registration results in a change of vehicle category from a goods carrying vehicle (Category N series) to a passenger carrying vehicle (Category MA, MB and MC), the modified vehicle must be certified as a vehicle which has undergone a second stage of manufacture and be affixed with a second stage of manufacture plate.

If a goods carrying vehicle that has already been registered and used, is converted to a passenger carrying vehicle by the fitting of additional seats, engineering evidence must be provided that the vehicle meets those higher safety standards.

A goods carrying vehicle becomes a passenger carrying vehicle when the total number of seating positions multiplied by 68 kg is 50% or more of the vehicle's load carrying capacity.

Registration Authorities in Australia have recognised the need for guidelines to assist those individuals who wish to construct and install their own additional seats in vehicles. To this end, the following two codes of practice were developed – Vehicle Standards Bulletin VSB 5A, *Commercial Manufacture and Installation of Additional Seats* and Vehicle Standards Bulletin VSB 5B *Construction and Installation of Additional Seats by Individuals*.

If these Guidelines are followed closely, the completed installation will be accepted by all State and Territory Registration Authorities as providing an acceptable level of occupant protection without having to demonstrate compliance with the latest edition of the ADRs.

Both codes of practice may be downloaded from the Department of Infrastructure and Transport website located at: www.infrastructure.gov.au or may be found on the CD published by that Department that contains the ADRs. (The CD is not available free of charge and needs to be purchased from the Department).

Vehicle Standards Bulletin VSB 5A, Commercial Manufacture and Installation of Additional Seats (VSB 5A)

This National Code of Practice provides information for the commercial manufacture and installation of additional seating and provides supplementary information on seatbelts, seatbelt anchorages and their correct installation. It applies to vehicle manufacturers, vehicle modifiers, seat manufacturers and seat suppliers.

Vehicle Standards Bulletin VSB 5B Construction and Installation of Additional Seats by Individuals (VSB 5B)

This National Code of Practice is intended to assist individuals who wish to construct and install additional seats for their own use and to ensure that when these seats are installed they comply with an acceptable level of occupant protection and comfort. Supplementary information on seatbelts, seatbelt anchorages and their correct installation is also provided.

2.1 FABRICATION

All work must be performed in accordance with recognised engineering standards. Cutting, heating, welding or bending of components should be avoided by choosing unmodified production components wherever possible.

2.1.1 Welding, Fasteners and Electroplating

Mandatory requirements and guidance on the above items are contained in Section LZ *Appendices*.

- For the use of fasteners refer to Appendix A *Fasteners*;
- For welding techniques and procedures refer to Appendix C *Heating and Welding of Steering Components*; and
- For electroplating refer to Appendix D *Electroplating*.

2.2 LADEN MASS LIMITS

The installation of items such as additional seats and/or roll-over protection devices may result in a substantial change in a vehicle's tare mass and may therefore significantly affect its load carrying capacity. Modifications to existing production vehicles must therefore take into account the following guidelines relating to laden mass:

- The laden mass of a vehicle, such as a passenger vehicle, must not exceed the vehicle manufacturer's recommended limit for the vehicle in question;
- In the case of vehicles with a designated Gross Vehicle Mass (GVM), the vehicle's GVM must not be exceeded;
- In all cases, the vehicle manufacturer's recommended individual axle loads must not be exceeded. For passenger vehicles a minimum loading allowance of 68 kg for each adult seating position must be included in the determination of laden mass. If provisions exist for carrying luggage, a minimum loading allowance of 13.6 kg for each seating position must be used for determining laden mass;
- A goods carrying vehicle (ADR category NA, NB) becomes a passenger carrying vehicle when the total number of seating positions multiplied by 68 kg is 50% or more of the vehicle's load carrying capacity. In this situation engineering evidence must be provided that the modified vehicle meets the higher safety standards applicable to passenger carrying vehicles; and
- In all cases where an installation results in a change in vehicle ADR category, the relevant Registration Authority must be contacted for further advice.

3 AUSTRALIAN DESIGN RULES

A modified vehicle must continue to comply with the ADRs to which it was originally constructed, except as allowed for in the AVSR.

Outlined in Table LK1 below are requirements and/or components of the vehicle that may be affected by the modifications and that may require re-certification, testing and/or data to show continuing compliance for the modified vehicle. This is not an exhaustive list and other modifications may also affect ADR compliance.

The applicable ADRs are individually listed on the Identification Plate of Second Edition ADR vehicles. For Third Edition ADR vehicles, the Identification Plate contains the vehicle category and the date of manufacture, from which the applicable ADRs can be determined (refer to the applicability tables in Section LO *ADR Compliance*).

For early model vehicles, it is recommended that any replacement or additional seat should meet the intent of ADR 3 and should incorporate head restraints complying with ADR 22.

Table LK1 Summary of items that if modified, may detrimentally affect compliance with applicable ADRs

Title and Comments	ADR
Seat Anchorages	3x, 3/...
Seatbelts	4x, 4/...
Anchorages for Seatbelts and Child Restraints	5x, 5/...
Internal Sun Visors	11, 11/...
Rear Vision Mirrors	14, 14/...
Instrument Panels	21, 21/...
Head Restraints	22x, 22/...
Child Restraint Anchorages	34x, 34/...
General Safety Requirements	42/...
Frontal Impact Protection	69/...
Side Impact Protection	72/...
Offset Impact Protection	73/...

4 BASIC MODIFICATIONS WITHOUT CERTIFICATION

The following modifications may be carried out without certification under an LK Code, provided that the vehicle continues to comply with relevant ADRs and AVSR and provided that the vehicle meets the following general safety requirements.

4.1 OPTIONAL SEATS

Manufacturer's optional seats may be fitted provided that:

- the seats, seatbelts and all other associated components are from the same make and model as the vehicle to which they are being fitted;
- the installation is in accordance with the manufacturer's specifications;
- all components used are unmodified;
- the seating capacity is unaltered; and
- the safety features of the seat are not downgraded (e.g. seats fitted with side airbags are not replaced with seats that do not have this feature or are not compatible with the parent vehicle safety systems).

5 CERTIFIED MODIFICATIONS (LK CODES)

This section specifies particular requirements and covers limitations on the modifications that may be carried out under individual LK Codes.

Each Code is supplemented with a checklist (refer to Table LK2).

Table LK2 LK Code Directory

LK CODE DIRECTORY		PAGE
LK1	Seat and Seatbelt Installation/Removal	10
	Checklist	19
LK2	Seat and Anchorage Certification	22
	Checklist	26
LK6	Child Restraint Anchorage Installation	28
	Checklist	38
LK8	Construction and Installation of One-Off Roll-bars and Roll-cages by Individuals	39
	Checklist	51
LK9	Design and Manufacture of Commercial Aftermarket Roll-bars, Roll-cages and Other Types of ROPS	53
	Checklist	59
LK10	Installation of Aftermarket Roll-bars, Roll-cages and ROPS	62
	Checklist	66

SEAT AND SEATBELT INSTALLATION / REMOVAL

CODE LK1

SCOPE

Code LK1 provides for the installation of seats and seatbelts that have already been certified as complying with the applicable ADRs to seat anchorages and seatbelt anchorage points that have already been certified as complying with the applicable ADRs.

Code LK1 also provides for the removal of seats and seatbelts to reduce seating capacity.

Code LK1 does not apply to ADR Category L-Group vehicles and motor cycles.

MODIFICATIONS COVERED UNDER CODE LK1

The following is a summary of the modifications that may be performed under Code LK1.

- Installation of complying seats to complying anchorage points;
- Installation of complying seatbelts to complying anchorage points;
- Installation of complying seat and seatbelt anchorages; and
- Removal of seats and seatbelts to reduce seating capacity.

A *complying seat* means a seat that already complies with the appropriate clauses of ADR 3/..., VSB 5A or VSB 5B. e.g. an original seat taken from a production vehicle that complies with the ADRs is a *complying seat*, providing the seat is in good condition and unmodified.

A *complying seatbelt* is a seatbelt that:

- has been designed to comply with the ADRs applicable to the vehicle to which it will be fitted (e.g. a spare part), or
- has been taken from a production vehicle that complies with the ADRs, or
- for pre-ADR vehicles complies with AS/NZS 2596.

A *complying anchorage point* means an anchorage point that already exists in a vehicle that was designed to comply with the ADRs or is an anchor point kit supplied with a *complying seat* or a *complying seatbelt*.

MODIFICATIONS NOT COVERED UNDER CODE LK1

The following modifications may not be carried out under code LK1:

- Installation of non-complying seats to vehicles that were built to comply with the ADRs;
- Installation of seatbelts that do not comply with AS/NZS 2596 or ADR 4/...; and
- Installation of replacement front seats to vehicles manufactured to comply with ADR 69 or ADR 73, unless the seat is a manufacturer's option.

COMPLIANCE WITH APPLICABLE VEHICLE STANDARDS

Modified vehicles must continue to comply with the ADRs to which they were originally constructed, except as allowed for in the AVSR. These modified vehicles must also comply with the applicable in-service requirements of the AVSR.

Modified pre-ADR vehicles must continue to comply with the AVSR.

Compliance with the AVSR also means compliance with the equivalent regulations of a State or Territory of Australia.

Outlined below in Table LK3 are areas of the vehicle that may be affected by the modifications and that may require re-certification, testing and/or data to show compliance for the modified vehicle. This is not an exhaustive list and other modifications may also affect ADR compliance.

Table LK3 Summary of items that if modified, may detrimentally affect compliance with applicable ADRs

DETAIL	REQUIREMENTS
Seats and seat anchorages	ADR 3x, 3/..., VSB 5A or VSB 5B
Seatbelts	ADR 4x, 4/..., AS/NZS 2596
Seatbelt anchorages	ADR 5x, 5/...
Child restraint anchorages	ADR 5/..., 34x, 34/...
Impact/occupant protection	ADR 69/..., 72/..., 73/...

To determine the ADRs that apply to the vehicle in question, refer to the applicability tables in Section LO. Vehicles manufactured on or after 1 January 1969 and prior to 1 July 1988 need to comply with the Second Edition ADRs whilst vehicles manufactured after this date need to comply with the Third Edition ADRs. Section LO has separate applicability tables for each edition.

Alternatively, ADR applicability tables for individual vehicle categories may be referenced on the Department of Infrastructure and Transport *RVCS* website at the following address and under the section titled *ADR Applicability Tables*:

<http://rvcs.dotars.gov.au/>

The ADRs apply according to the vehicle's category and date of manufacture. It is the responsibility of the signatory to refer to the appropriate ADR applicable to the vehicle.

SPECIFIC REQUIREMENTS

The following are specific requirements for complying seat replacements under Code LK1.

The approval must also comply with the general guidelines contained in sub-section 2 *General Requirements*.

1. SEAT REQUIREMENTS

Additional or replacement seats must be installed in accordance with the current issue of Standards Bulletin VSB 5A, *Commercial Manufacture and Installation of Additional Seats* or Standards Bulletin VSB 5B *Construction and Installation of Additional Seats by Individuals*.

Code LK1 also allows bench seats to be replaced with bucket seats and bucket seats to be replaced with bench seats in vehicles that were not built to comply with ADR 69 or ADR 73. However, where the latter modification is performed an additional seatbelt must be provided for the centre seating position except where:

- The design of the transmission tunnel is such that it is impractical for a person to sit in the centre of the seat, or
- There is insufficient space for a third seating position when calculated in complete multiples of 410mm for each seating position – in other words, when the width of the bench seat is less than 1230mm.

1.1 Seat Anchorage Construction

Single seats may be adequately anchored to sheet steel floors by using not less than four 8mm ISO Grade 8.8 (5/16 inch UNF SAE Grade 5) bolts, with a mild steel reinforcement backing plate of an area not less than 3750mm² in contact with the mounting surface and a thickness not less than 3mm at each anchorage point. For double and triple seats, the number/size of anchorage points should be increased accordingly.

The shape of the backing plates must match the contour of the floor material. The corners of the reinforcement plates must have a minimum radius of 5mm and the edges adjacent to the floor material must be chamfered.

The anchor bolts must be tightened to the correct tension and fully engage all the thread of the nut.

In cases where seatbelt anchorages are fixed to the seat assembly, the seat anchorages must be certified in accordance with the requirements of Code LK2.

Anchorage must not be fitted through wood, fibreglass, sheet aluminium or plastic or where wood or other non-metal material is sandwiched between steel unless certified in accordance with the requirements of Code LK2.

Unless supported by engineering evidence, seats located over wooden floors must be anchored to the vehicle structure via steel members (e.g. C - section, channel section or rectangular hollow section) of adequate strength to meet the strength requirements specified in VSB 5A or VSB 5B.

1.2 Seat Anchorage Location

Replacement seats must be located so that the occupant's seating reference point is as close as possible to that of the original seat.

Front seats must face forward and be parallel to the longitudinal centreline of the vehicle.

Seats should be located so as to allow freedom of adjustment throughout the complete range of travel.

Care should be taken when fitting replacement seats in utilities or other vehicles where windows are close to the back of the seat. Seat back or head restraints should not press against the window panel in the most rearward position of the seat.

2 SEATBELT REQUIREMENTS

Where additional seats are to be fitted (e.g. into a van or station wagon) the Vehicle Standards Bulletin VSB 5A, *Commercial Manufacture and Installation of Additional Seats* or Vehicle Standards Bulletin VSB 5B *Construction and Installation of Additional Seats by Individuals* apply.

Note: This will generally mean that *Retractor Belts* will need to be fitted. Installation of retractor assemblies require careful attention to detail and therefore must be installed as directed by the seatbelt assembly manufacturer. Incorrect installation may result in the assembly not operating as intended.

When replacing a vehicle's front bench seat with bucket seats or vice-versa, seatbelts must be fitted in accordance with the ADRs applicable for that particular vehicle's ADR category and the date of its original manufacture.

Any replacement or additional seatbelt should be new and comply with Australian Standard 2596 (*Seatbelt Assemblies for Motor Vehicles*). For vehicles originally built to comply with the ADRs, replacement belts must comply with ADR 4 or with Australian Standard 2596 (*Seatbelt Assemblies for Motor Vehicles*), and must:

- carry the manufacturer's identification, date of manufacture, part number or other identification, such as an E or SAA marking;
- have the fixed part of the buckle either on a stalk, properly adjusted strap or fixed length strap, be located against the occupant's hip when buckled up and restrained from falling on the floor when unbuckled;
- have webbing and stalk installations such that no obstruction results in a significant change of direction between anchorage and occupant. If such an obstruction exists, a complete analysis of the belt/set installation system must be carried out;
- pass through all sash guides smoothly without any edge loading or twisting which might cause premature wear; and
- provide neat, obstruction free stowage with accessibility and excess length meeting ADR 4 requirements.

2.1 Seatbelt Anchorage Strength

Seatbelt anchorages must be able to meet the applicable strength requirements given in VSB 5A or VSB 5B.

2.2 Seatbelt Anchorage Construction

Seatbelts must be adequately anchored to a steel floorpan, upper body or pillar by using bolts designed specifically for anchoring seatbelts. Seatbelts are usually supplied in kit form with the appropriate anchor bolts and backing plates. If not, they may be purchased separately.

Lower and upper anchoring systems employ different mountings as shown in Figure LK1 below.

If the backing plate supplied with the seatbelt is not suitable because of its shape or dimensions, an alternative backing plate may be used. It must have an area not less than 3750mm² in contact with the mounting surface and a thickness of 3 - 4.5mm (1/8 - 3/16 inch).

The reinforcement backing plate and anchor bolt should be positioned so that the backing plate is loaded approximately centrally. Edge loading should be avoided.

The shape of the backing plates must match the contour of the floorpan/pillar material in the region of the anchorage. The corners of the reinforcement plates must have a minimum radius of 5mm and the edges adjacent to the body must be chamfered. The anchor bolts must be tightened to the correct tension and fully engage all the thread of the nut.

The ductility of low carbon steel is beneficial in allowing redistribution and sharing of loads, and plastic deformation helps to absorb impact energy.

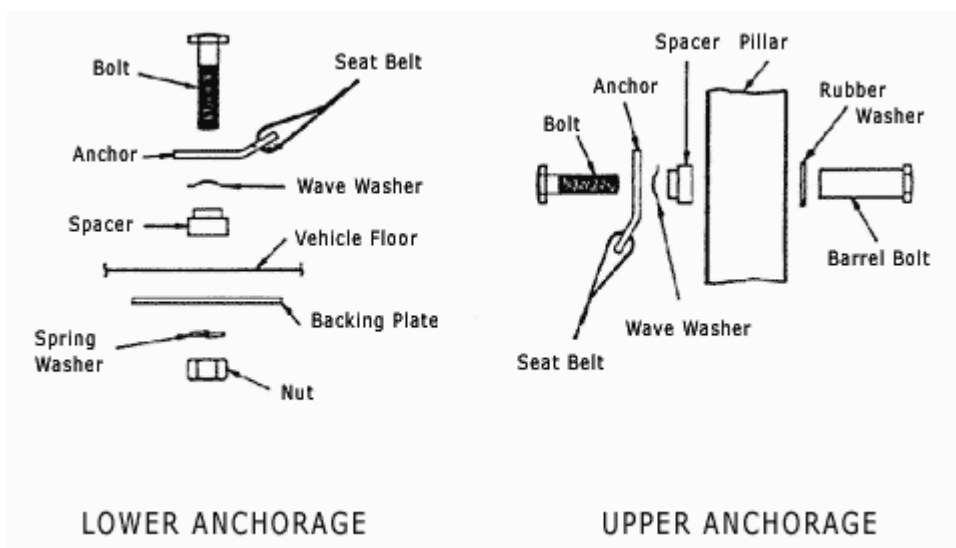

Figure LK1 Typical Lower Anchorage and Upper Anchorage Installations

Anchorage must not be fitted through wood or where wood or other non-metallic material is sandwiched between steel. Anchorage must not be fitted to any part of the vehicle which is affected by rust or impact damage.

Anchorage must not be fitted to wooden, aluminium, plastic or fibreglass panels unless the anchorage has been physically tested and certified in accordance with Code LK2.

2.3 Locations of Anchorages

Only seatbelt anchorages of a type determined by ADR 5 *Anchorage for Seatbelts and Child Restraints* may be installed.

2.3.1 Lap Anchorages

The two lap anchor points for a particular seating position must be located on opposite sides of the Seating Reference Plane (longitudinal centreline of the seat) a minimum distance of 165mm apart. A distance of 250mm to 350mm between the anchorages is desirable. See Figure LK2.

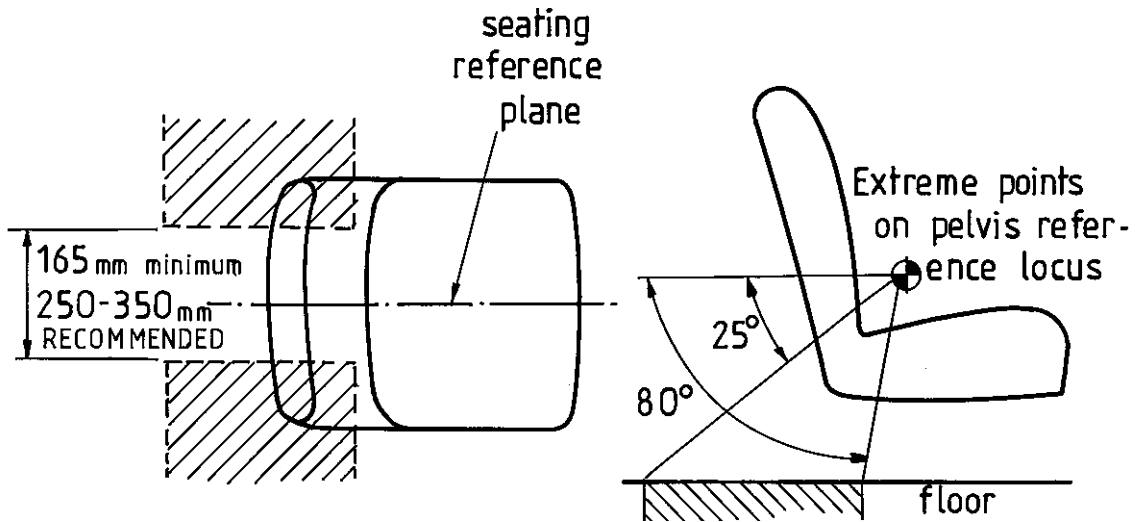

Figure LK2 Lap anchorages must be located within shaded areas

Unless supported by engineering evidence, the lower seatbelt anchorages must not be superimposed, i.e. each seatbelt must be anchored by separate bolts. The anchorages provided for different seating positions must be separated by at least 200mm.

In cases where the lap strap is not in a straight line when viewed from the side, the positioning of the anchorage points should be such that the requirements of Clause 5 of ADR 5 are met.

Since most seatbelts are made to a standard length, it is not good practice to have the anchorage points too far behind the seat. The buckle strap should be of such length that the buckle is accessible and at the side of the hip of the seat occupant, but not so long that the buckle rests on the seated person's abdomen.

Where a seatbelt is mounted on a seat, the two pelvic restraint anchorages must be mounted on the seat to maintain the positional relationship between the retractor assembly and the Seating Reference Point. Care should be taken to ensure that the seat, seat anchorages and seatbelt anchorages are of sufficient strength.

2.3.2 Sash Location Point

A sash guide must be fitted for each seating position fitted with a lap sash belt.

Lap sash and harness belts must not be used on side facing seats. These seats may be fitted with lap belts only.

The sash location point must lie in *Area A* and must be at least 140mm from the Seating Reference Plane (see Figure LK3).

Where the distance of the sash location point to the seating reference plane(s) is less than 200mm, *Area A* is extended to include the area contained within KPQT.

$$CR = 315 + 1.6 s \quad MJ = 1.3s$$

$$RB = 260 + s \quad MP = 250$$

All Dimensions are in mm

s = the shortest transverse distance in mm from the seating reference plane to the sash location point under consideration.

When s is less than 200mm, *Area A* is extended to include the area contained within KPQT.

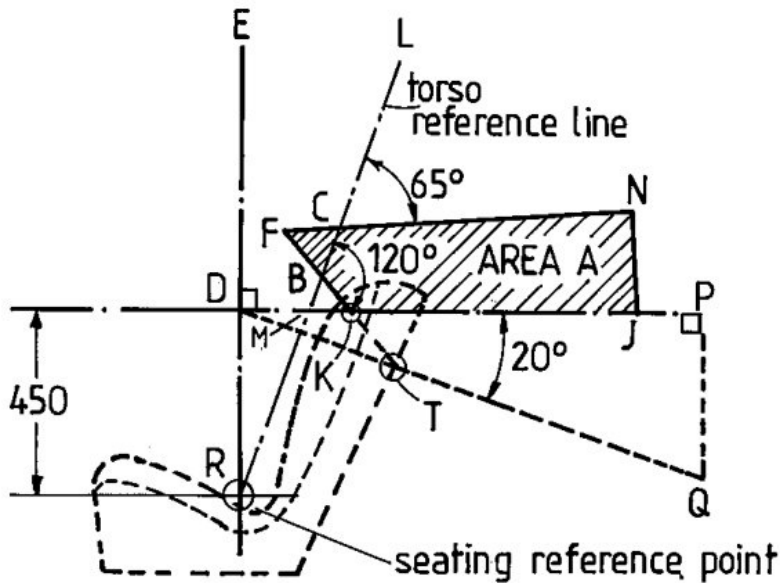

Figure LK3 Location of Area A Construction Detail

2.3.3 Harness Anchor Point

In cases where only one harness anchorage is provided, the anchor point must be located:

- rearward of a transverse plane inclined at the same angle as the Torso Reference Line and 500mm horizontally rearward of the Seating Reference Point (see Figure LK3);
- not more than 50mm from the seating reference plane; and
- within Area B (see Figure LK4).

In cases where two harness anchorages are provided for a particular seating location, the anchor points must be located:

- rearward of a transverse plane inclined at the same angle as the Torso Reference Line and 75mm horizontally rearward of the Seating Reference Point;
- either side of the Seating Reference Plane in such a way that the distance from the Seating Reference Plane does not differ by more than 100mm;
- such that the transverse separation is either 250-300mm or less than 250mm by not more than half the horizontal distance from either anchor point to the transverse plane through the Torso Reference Line; and
- within Area B (see Figure LK4).

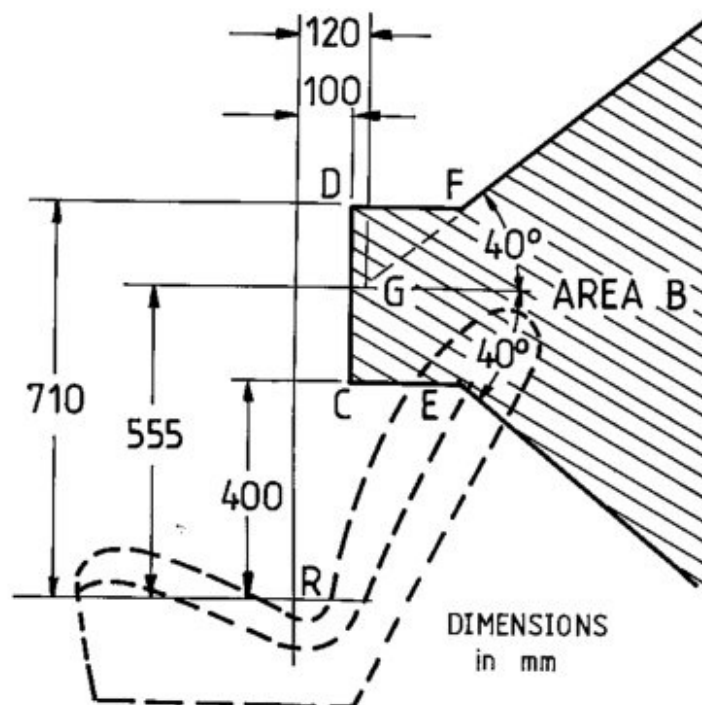

Figure LK4 Location of Area B

3 DEFINITIONS

The following terms are defined in the ADRs which contain more detailed explanations of the requirements for locations of seatbelt anchorage points.

ADR 5 *Anchorage for Seatbelts and Child Restraints.*

ADR 34 *Child Restraint Anchorages and Child Restraint Anchor Fittings*

Seating Reference Plane: the vertical longitudinal plane through the geometric centre of the seat.

Seating Reference Point: simulates the position of the pivot centre of human torso and thigh in the rearmost normal seating position of the centre of a 100mm diameter disc placed in the Seating Reference Plane at the join of the seat and backrest. See Figure LK3.

Pelvis Reference Point: simulates the correct position of a lap strap when worn by the seat occupant. It is located at a height of 95mm above and 70mm forward of the *Seating Reference Point*.

Torso Reference Line: a line passing through the *Seating Reference Point* and parallel to the backrest. For seats with an adjustable backrest, it is a line passing through the *Seating Reference Point* at an angle of 30° from the vertical. See Figure LK3.

Harness Belt: a seatbelt assembly consisting of at least one strap designed to provide pelvic restraint and two or more torso straps designed to provide upper torso restraint.

4 REMOVAL OF SEAT(S) AND SEATBELT(S) TO REDUCE SEATING CAPACITY

Seats and seatbelts may be permanently removed to reduce seating capacity of the vehicle. The vehicle must be certified to represent the new seating capacity. All holes in the bodywork must be blanked off.

Any removal of seats and/or seatbelts to achieve a reduction in seating capacity must not interfere with the vehicle's *Supplementary Restraint System* (SRS). For example removing a front seat and seatbelts with pre-tensioners may disarm the entire vehicle SRS and therefore would not be able to be certified.

If the reduction in seating capacity results in a change of vehicle category the signatory must show that the vehicle complies with all additional ADRs that may now apply to that vehicle.

CHECKLIST LK1

SEAT AND SEATBELT INSTALLATION/REMOVAL

CODE LK1

(N/A=Not Applicable, Y=Yes, N=No)

1	SEATS			
1.1(a)	Have all <u>additional</u> seats been certified to Code LK2 in accordance with the requirements of the ADRs or the National Code of Practice for the manufacture of additional seats (VSB 5A or VSB 5B)? (Design Approval No.....)	N/A	Y	N
1.1(b)	Do commercial installations comply with VSB 5A?	N/A	Y	N
1.2	Do all <u>replacement</u> seats meet the strength requirements given in Clause 3.2 of ADR 3/... for the date of manufacture of the vehicle?	N/A	Y	N
1.3	Are the seats mounted on existing anchorage points or anchorage points fitted in accordance with sub-sections 1, 2 and 3 of Code LK1?	N/A	Y	N
1.4	If the additional replacement seats are hinged, or have hinged backs, do they meet the requirements for these seats given in Clause 3.2.3 of ADR 3/...?	N/A	Y	N
1.5	Are the head and leg space requirements of VSB 5 satisfied?	N/A	Y	N
1.6	Are the additional seat(s) positioned away from areas where there would be a high probability of injury to the occupant(s) in an accident?	N/A	Y	N
1.7	Is access to additional seats unimpeded?	N/A	Y	N
1.8	With the installation of any additional seats, is access to exits, access aisles, doors, door latches, folding seat controls, etc. unobstructed?	N/A	Y	N
1.9	Are seat backs, armrests and other fittings padded to minimise injury to occupants in an accident?	N/A	Y	N
1.10	Is adequate rear vision for the driver maintained or have additional mirrors been fitted to maintain adequate rear vision?	N/A	Y	N
1.11	Are all rearward facing seats fitted with irremovable head restraints?	N/A	Y	N
1.12	Are Category 2 and Category 3 seats labelled or plated in accordance with VSB 5A or VSB 5B?	N/A	Y	N
1.13	If seats have been permanently removed, have all holes been adequately sealed?	N/A	Y	N

[Continued overleaf]

(N/A=Not Applicable, Y=Yes, N=No)

2	SEATBELTS			
2.1	Is the type of seatbelt fitted in accordance with that determined by the anchorage system specified for the particular application by ADR 5 <i>Anchorage for Seatbelts and Child Restraints</i> ?	N/A	Y	N
2.2	Are the seatbelts fitted to existing complying anchorage points or to anchorage points fitted in accordance with VSB 5A or VSB 5B?	N/A	Y	N
2.3	Do the seatbelts comply with the requirements of the applicable version of ADR 4?	N/A	Y	N
2.4	<u>If seats have been removed:</u> Has the vehicle supplementary restraint system not been affected by the removal of any seats and/ or seatbelts?	N/A	Y	N
3	SEATING CAPACITY			
3.1	New Seating Capacity..... NB: This may need to be recorded by the Registration Authority.	N/A		
4	WORKMANSHIP			
4.1	Is all work, including welding, of satisfactory quality and has all work been performed in accordance with recognised engineering standards?		Y	N
5	ADR COMPLIANCE			
5.1	Does the modified vehicle continue to comply with applicable ADRs?	N/A	Y	N

Note: If the answer to any question is **N (No)**, the modification cannot be certified under Code LK1.

[Continued overleaf]

CERTIFICATION DETAILS																
Make						Model						Year of Manufacture				
VIN																
Chassis Number (If applicable)																
Brief Description of Modification/s																
Vehicle Modified By																
Certificate Number (If applicable)																
Vehicle Certified By (<i>Print</i>)																
Signatory's Employer (If applicable)																
Signatory's Signature											Date					

SEAT AND ANCHORAGE CERTIFICATION

CODE LK2

SCOPE

Code LK2 provides for the certification of seat designs, the certification of seat anchorages and the certification of seatbelt anchorages mounted integrally on a seat.

Code LK2 does not apply to ADR Category L-Group vehicles and motor cycles.

MODIFICATIONS COVERED UNDER CODE LK2

The following is a summary of the modifications that may be certified under Code LK2:

- Certification of seat design;
- Certification of seat anchorages; or
- Certification of seatbelt anchorages mounted integrally on a seat.

MODIFICATIONS NOT COVERED UNDER CODE LK2

The following modifications may not be performed under Code LK2:

- Seat and seat anchorage installation;
- Seatbelt and seatbelt anchorage installation; or
- Child restraint anchorage installation.

COMPLIANCE WITH APPLICABLE VEHICLE STANDARDS

Modified vehicles must continue to comply with the ADRs to which they were originally constructed, except as allowed for in the AVSR. These modified vehicles must also comply with the applicable in-service requirements of the AVSR.

Modified pre-ADR vehicles must continue to comply with the AVSR.

Compliance with the AVSR also means compliance with the equivalent regulations of a State or Territory of Australia.

Outlined below in Table LK4 are areas of the vehicle that may be affected by the modifications and that may require re-certification, testing and/or data to show compliance for the modified vehicle. This is not an exhaustive list and other modifications may also affect ADR compliance.

Table LK4 Summary of items that if modified, may detrimentally affect compliance with applicable ADRs

DETAIL	REQUIREMENTS
Seats and seat anchorages	ADR 3x, 3/..., VSB 5
Seatbelts	ADR 4x, 4/..., AS/NZS 2596
Seatbelt anchorages	ADR 5x, 5/...
Child restraint anchorages	ADR 5/..., ADR 34x, 34/...

To determine the ADRs that apply to the vehicle in question, refer to the applicability tables in Section LO. Vehicles manufactured on or after 1 January 1969 and prior to 1 July 1988 need to comply with the Second Edition ADRs whilst vehicles manufactured after this date need to comply with the Third Edition ADRs. Section LO has separate applicability tables for each edition.

Alternatively, ADR applicability tables for individual vehicle categories may be referenced on the Department of Infrastructure and Transport *RVCS* website at the following address and under the section titled *ADR Applicability Tables*:

<http://rvcs.dotars.gov.au/>

The ADRs apply according to the vehicle's category and date of manufacture. It is the responsibility of the signatory to refer to the appropriate ADR applicable to the vehicle.

SPECIFIC REQUIREMENTS

1 SEAT AND SEAT ANCHORAGES

Seats and seat anchorages must be able to withstand the force requirements specified in the National Code of Practice for the manufacture of additional seats VSB 5A or VSB 5B.

In cases where seatbelt anchorages are fixed to the seat assembly, the seat anchorages must satisfy the additional force requirements from the seatbelt loadings.

Unless supported by engineering evidence, seats located over wooden floors must be anchored to the vehicle structure via steel members (e.g. C - section channel or rectangular hollow section) of adequate design to meet the strength requirements.

Seats and seat anchorages must be physically tested or fully certified by engineering calculations in accordance with VSB 5A or VSB 5B requirements.

2 SEATBELT ANCHORAGES

Seatbelt anchorages must be able to meet the applicable strength requirements specified in the National Code of Practice for the manufacture of additional seats VSB 5A or VSB 5B.

Seatbelt anchorages located in wooden floors must be anchored to the vehicle structure via steel members (e.g. C - section channel or rectangular or hollow section) of adequate design to meet the strength requirements.

Seatbelt anchorages must be physically tested or fully certified by engineering calculations in accordance with the VSB 5A or VSB 5B requirements.

3 ENERGY ABSORBING (PADDED) SEAT BACKS

Energy absorbing material (padding) is required on all seats that have seats behind them, that is:

- front row seats in vehicles with two rows;
- front and second row seats in vehicles with three rows; and
- front, second and third row seats in vehicles with four rows.

Energy absorbing material is not required on:

- seats in vehicles with a single row of seats; or
- seats installed back to back (i.e. when a rear facing seat is installed immediately behind a forward facing seat); and

The padding is required on the parts of the seat backs indicated in the figures below.

3.1 Padding location requirements

The location for energy absorbing material is illustrated in Figure LK5(a) for seats without headrests and in Figure LK5(b) for seats with headrests.

Area 1

The whole of *Area 1* must be capable of meeting the requirements outlined below (i.e. the whole of the dark shaded area must be padded).

Area 2

All surfaces with a radius of curvature less of than 5mm in *Area 2* must be capable of meeting the requirements outlined below (i.e. the edges of frame members and the like in the lighter shaded area must be padded).

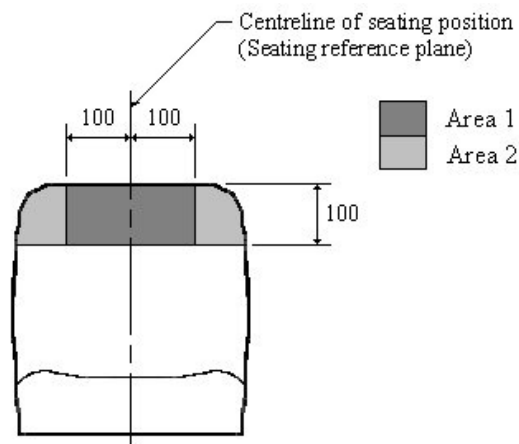

Figure LK5(a) Seat Without Headrest

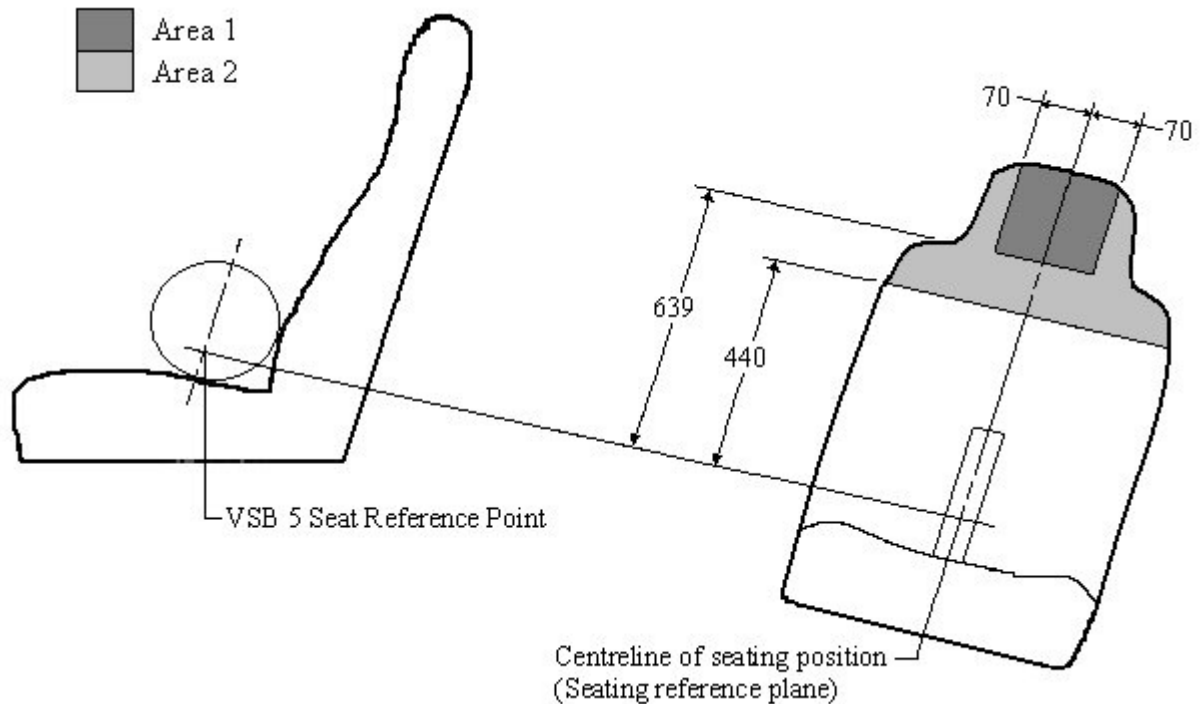

Figure LK5(b) Seat With Headrest

Figure LK5 Padding Location Requirements for Seats, With or Without Headrests

3.2 Test Requirements

Seat backs must be tested according to the requirements of ADR 3/02 *Energy Dissipation Test* (clause 6.4). This requires a 6.8 kg, 165mm diameter rigid spherical headform to contact the surfaces in *Area 1* and *Area 2* at a velocity of not less than 6.69 m/s (24 km/h). The deceleration of the headform should not be more than 80 times the acceleration due to gravity (80 g) for more than 3 milliseconds.

Alternatively, materials that have been shown to meet the performance requirement above, when mounted on a structure of at least the same stiffness as the seat back on which they are to be installed, may be used (refer to Appendix B *Foam Padding for Occupant Protection* of Section LZ *Appendices* for details of acceptable materials).

CHECKLIST LK2
SEAT AND ANCHORAGE CERTIFICATION
CODE LK2

(N/A=Not Applicable, Y=Yes, N=No)

1	SEAT AND SEAT ANCHORAGE CERTIFICATION			
1.1(a)	Do the seat anchorages meet the strength requirements specified in the national code of practice for the manufacture of additional seats VSB 5A or VSB 5B?	N/A	Y	N
1.1(b)	Are commercial installations in conformity with VSB 5A?	N/A	Y	N
1.2	Does the seat and head restraint meet the strength and deflection requirements?	N/A	Y	N
1.3	Are seats anchored through non-structural floors (e.g. wood or fibreglass) adequately anchored to the vehicle structure (i.e. with <i>C section</i> channel or RHS steel members)? If not, has engineering or testing evidence been provided that demonstrates the suitability of the anchorage system?	N/A	Y	N
2	SEATBELT ANCHORAGE CERTIFICATION			
2.1	Do the seatbelt anchorages meet the strength requirements given in the national code of practice for the manufacture of additional seats VSB 5A or VSB 5B?	N/A	Y	N
2.2	Are all anchorage bolts specified as 7/16 inch UNF SAE Grade 8?		Y	N
2.3	Are the seatbelt anchor points for each particular seating position located in accordance with the specifications in Section 5.4 of ADR 5?		Y	N
2.4	Are all side-facing positions fitted with lap seatbelts only?	N/A	Y	N
2.5	Are all seatbelt anchorages located to allow the seatbelt to be worn in a comfortable and safe position?		Y	N
3	PADDING LOCATION REQUIREMENTS			
3.1	Is the whole of <i>Area A</i> padded on the back of seats that require padding as specified in clause 3.		Y	N
3.2	Are all surfaces with a radius of curvature less of than 5mm in <i>Area 2</i> covered with padding?		Y	N
3.3	Does the seat back or alternative material used as padding meet the specified Test Requirements?		Y	N

Note: If the answer to any question is **N (No)**, the design cannot be certified under Code LK2.

[Continued overleaf]

CERTIFICATION DETAILS																
Make						Model						Year of Manufacture				
VIN																
Chassis Number (If applicable)																
Brief Description of Modification/s																
Vehicle Modified By																
Certificate Number (If applicable)																
Vehicle Certified By (<i>Print</i>)																
Signatory's Employer (If applicable)																
Signatory's Signature											Date					

CHILD RESTRAINT ANCHORAGE INSTALLATION CODE LK6

SCOPE

Code LK6 provides for the installation of child restraint anchorage systems that have been tested or otherwise approved by Registration Authorities.

Code LK6 does not apply to ADR Category L-Group vehicles and motor cycles.

MODIFICATIONS COVERED UNDER CODE LK6

The following is a summary of the modifications that may be certified under Code LK6.

- The location and drilling of an anchor hole into vehicles;
- The installation of a child restraint anchor bar;
- The installation of a Vertical Post;
- The installation of a Universal Frame; and
- The installation of a Twin Cab Device.

MODIFICATIONS NOT COVERED UNDER CODE LK6

The following modifications are not covered by Code LK6:

- The installation of restraints that have not been tested or approved by Registration Authorities; and
- The installation of seatbelts (this is covered by Code LK1).

COMPLIANCE WITH APPLICABLE VEHICLE STANDARDS.

Modified vehicles must continue to comply with the ADRs to which they were originally constructed, except as allowed for in the AVSR. These modified vehicles must also comply with the applicable in-service requirements of the AVSR.

Modified pre-ADR vehicles must continue to comply with the AVSR.

Compliance with the AVSR also means compliance with the equivalent regulations of a State or Territory of Australia.

Outlined below in Table LK5 are areas of the vehicle that may be affected by the modifications and that may require re-certification, testing and/or data to show compliance for the modified vehicle. This is not an exhaustive list and other modifications may also affect ADR compliance.

Table LK5 Summary of items that if modified, may detrimentally affect compliance with applicable ADRs

DETAIL	REQUIREMENTS
Seat Mountings	ADR 3x, 3/...
Seatbelt and Child Restraint Anchorages	ADR 5x, 5/..., ADR 34x, 34/...
Seatbelts	ADR 4x, 4/...

To determine the ADRs that apply to the vehicle in question, refer to the applicability tables in Section LO. Vehicles manufactured on or after 1 January 1969 and prior to 1 July 1988 need to comply with the Second Edition ADRs whilst vehicles manufactured after this date need to comply with the Third Edition ADRs. Section LO has separate applicability tables for each edition.

Alternatively, ADR applicability tables for individual vehicle categories may be referenced on the Department of Infrastructure and Transport *RVCS* website at the following address and under the section titled *ADR Applicability Tables*:

<http://rvcs.dotars.gov.au/>

The ADRs apply according to the vehicle's category and date of manufacture. It is the responsibility of the signatory to refer to the appropriate ADR applicable to the vehicle.

SPECIFIC REQUIREMENTS

Vehicles that do not have child restraint anchorage points may be modified to provide one or more child restraint anchorages.

The incorrect fitting of child restraint anchorages can result in the anchor point not having adequate strength to withstand the forces generated during a crash. This in turn means a child restrained in a child restraint utilising such an anchor point will not be offered sufficient occupant protection.

Child restraint anchorages can be fitted to a:

- parcel shelf of a sedan;
- Child Restraint Anchor Bar (CRAB Bar);
- Vertical Post;
- Universal Frame; or
- Twin Cab Device.

The following sections outline the minimum requirements for the installation of each of these restraint devices.

1 GENERAL

The drilling and location of anchor points in pre ADR 34 (July 1976) passenger vehicles must be in accordance with sub-section 2.0 of this Code.

The installation of specialised restraint anchorage equipment such as *CRAB Bars*, *Vertical Posts*, *Universal Frames*, or *Twin Cab Devices*, must be in accordance with the relevant clauses of this Code.

The installation and requirements for seatbelts must be in accordance with Code LK1.

Seatbelts used in conjunction with child restraints must be in a serviceable condition.

Only complying child restraints and restraint anchorage systems may be used.

All work performed must be in accordance with recognised engineering standards.

2 REAR PARCEL SHELF ANCHORAGES

Child restraint anchorages may be installed in pre ADR 34 (July 1976) passenger vehicles by utilising a standard anchor bracket and anchor bolt kit. The kit requires a 9mm diameter hole to be drilled in the rear parcel shelf. It is essential that the hole is:

- drilled through a substantially flat, structurally sound, rust free section of metal;
- located more than 50mm from any existing hole in the metal and within 40mm of the longitudinal centreline of the seating position. (see Figure LK6); and
- located in such a position so as to allow the top tether strap to be easily adjusted and to allow the easy engagement and disengagement of the anchorage fitting to the anchor bolt.

All components of the anchor bolt kit should be used; the spreader plate washer must be brought to bear on a flat surface on the underside of the parcel shelf.

Anchor bolt kits must not be used in pre-ADR 34 (1 Jan. 1977) station wagons and hatchbacks, unless a report from a signatory is provided that confirms that the rear seats together with their attachments are able to withstand the forces generated during a crash. The rear seats of these vehicles may not be designed to resist the forces generated during a crash and as a consequence, rear seat-back failure may occur. Alternative mounting structures such as a *CRAB Bar* or *Vertical Posts* should be used in these cases.

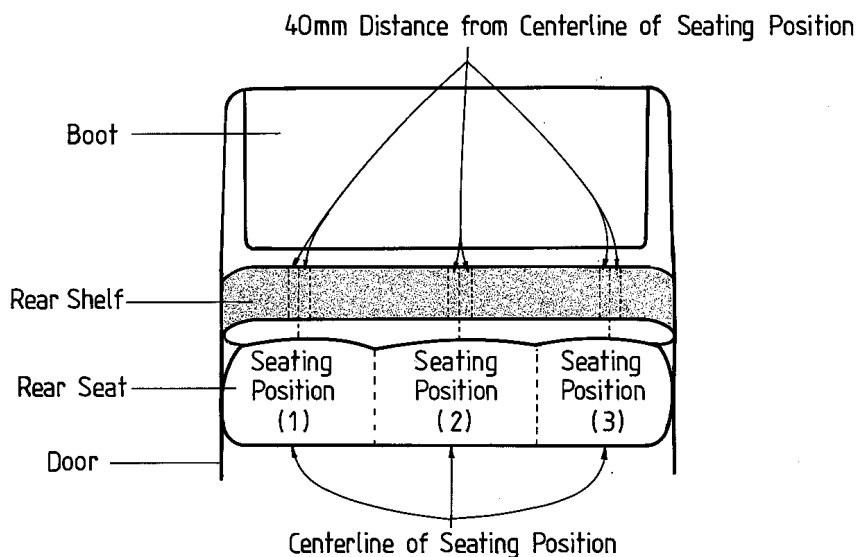

Figure LK6 Anchorage Positions

3 CHILD RESTRAINT ANCHORAGE BAR

In vehicles that do not have rear parcel shelves, (e.g. hatch-backs, station wagons, four wheel drive and forward control passenger vehicles) a device known as a *Child Restraint Anchorage Bar* (*CRAB Bar*) (Figure LK7) may be installed.

The *CRAB Bar* can incorporate anchorage points for up to three children, who each do not have a body plus restraint mass exceeding 32.5kg. It is suitable for the restraint of child seats and child safety harnesses.

CRAB Bars are currently available in two telescopic sizes to suit the width of the vehicle to which they will be fitted - 1250mm to 1460mm width for small to medium size vehicles and 1460 to 1600 for larger vehicles. The 1250 to 1460mm bar can be shortened to suit small vehicles by cutting the *Main Tube* and re-drilling the *Pilot Hole* to suit. The *Main Tube* and *Pilot Hole* are shown in Figure LK7. After shortening, the main tube must not have been reduced in length by more than 100mm of the distance between the proposed *CRAB Bar* anchor points.

The anchor bar must be installed in accordance with manufacturer's instructions.

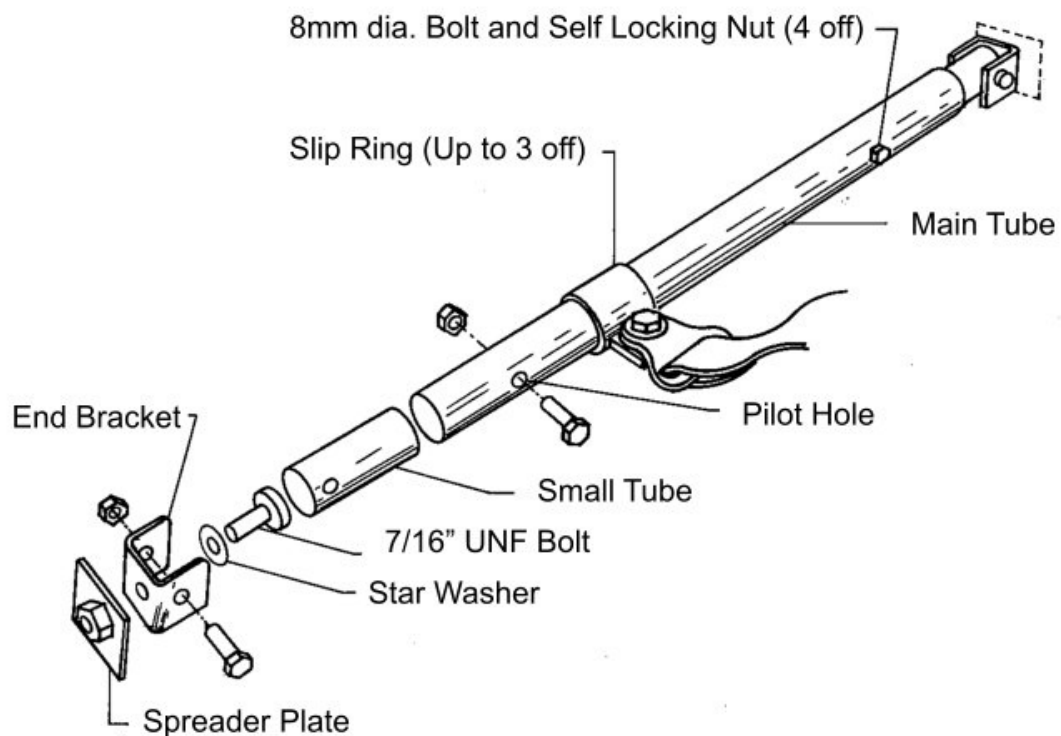

Figure LK7 Child Restraint Anchorage Bar

The *CRAB Bar* must be fitted not less than 200mm behind and not more than 100mm below the top rear edge of the seat back. To meet this requirement, it is recommended that the *CRAB Bar* be installed at waist rail height in the cross hatched area shown in Figure LK8.

Sufficient clearance must exist between the inner and outer body panels to accommodate the 7/16" UNF mounting bolt without it fouling the outer panels.

The spreader plate must have a flat surface on which to bear when positioned behind the panel. Failure to do this will result in distortion of the panel, which may lead to failure of the anchorage system in the event of a crash.

Drill a 12mm hole through inner body panel and install end bracket and spacer (if required) and spreader plate using 7/16" UNF bolt (refer to Figure LK9).

Unless supported by an engineering report, the *CRAB Bar* must not be used in vehicles with aluminium or composite body panels. For these vehicles, a *Vertical Post* may be a suitable alternative.

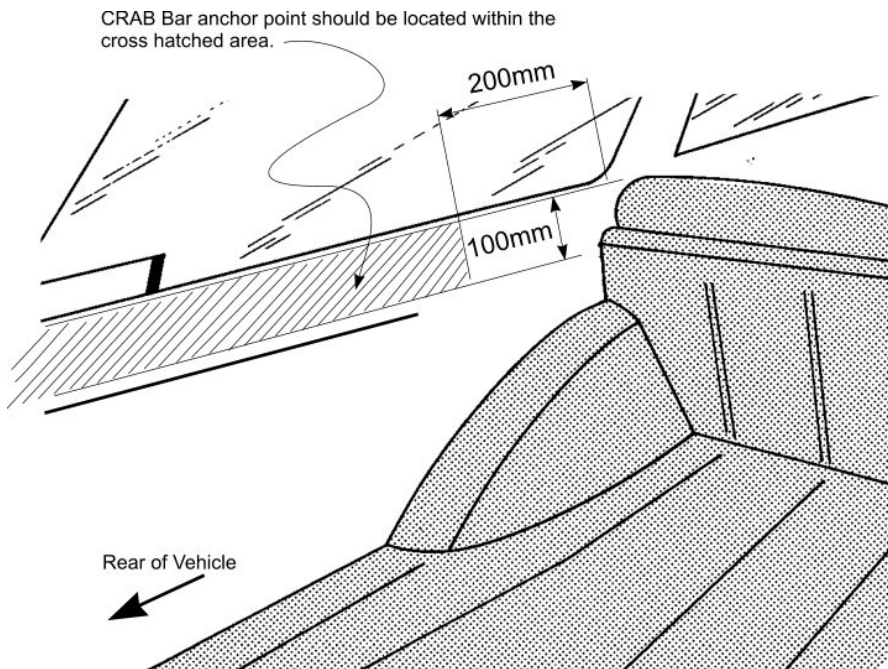

Figure LK8(a) *CRAB Bar* Location (Not to scale)

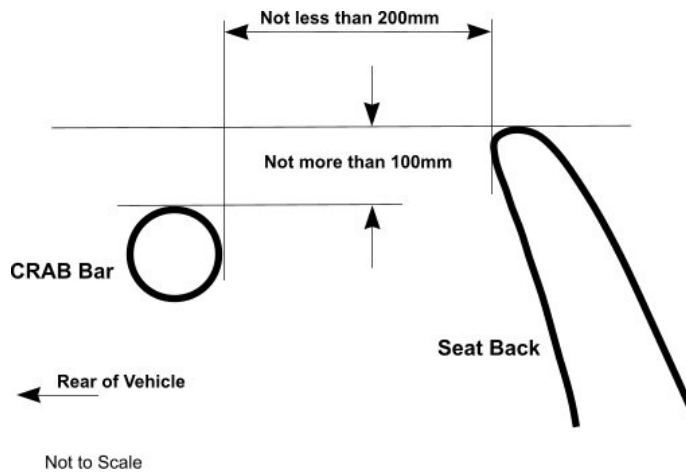

Figure LK8(b) *CRAB Bar* Location Relative to Seat Back (Not to scale)

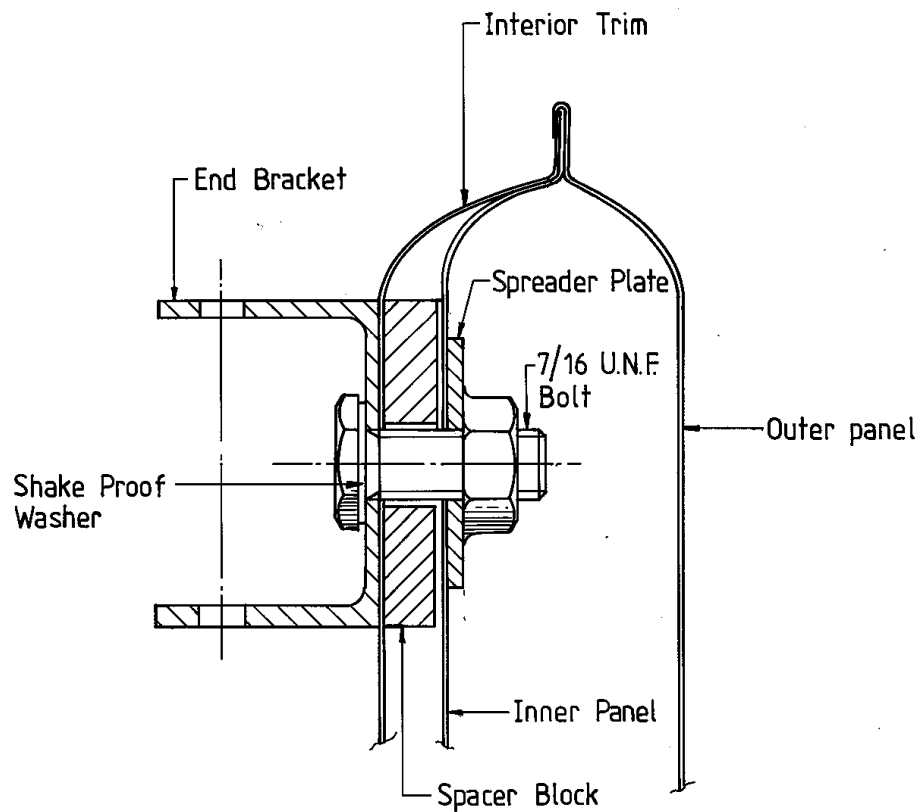

Figure LK9 Child Restraint Anchorage Bar Attachment

4 VERTICAL POST

An alternative to the *CRAB Bar* is the *Vertical Post*. This device (Figure LK10) is also suitable for provision of a single child restraint anchorage in station wagons, four wheel drive vehicles and forward control passenger vehicles.

The installation of a *Vertical Post* provides a single anchorage point and is suitable for any height of seat back up to 640mm. The device can be an anchorage for the installation of child seats and child safety harnesses.

The post must be installed in accordance with the manufacturer's instructions.

The centreline of the post must lie within 40mm of the longitudinal centreline of the child restraint when installed in the required seating position.

Load spreader plates must be utilised.

For corrugated floors, the base channel must be positioned so that holes are drilled through the middle of the *vee*. Spacers must be used to fill the depth of the *vee* (refer to Figure LK11).

The vertical tube may be reduced in height to suit seat back heights less than 640mm. Under no circumstances must the anchorage point be more than 100mm below the top of the seat back.

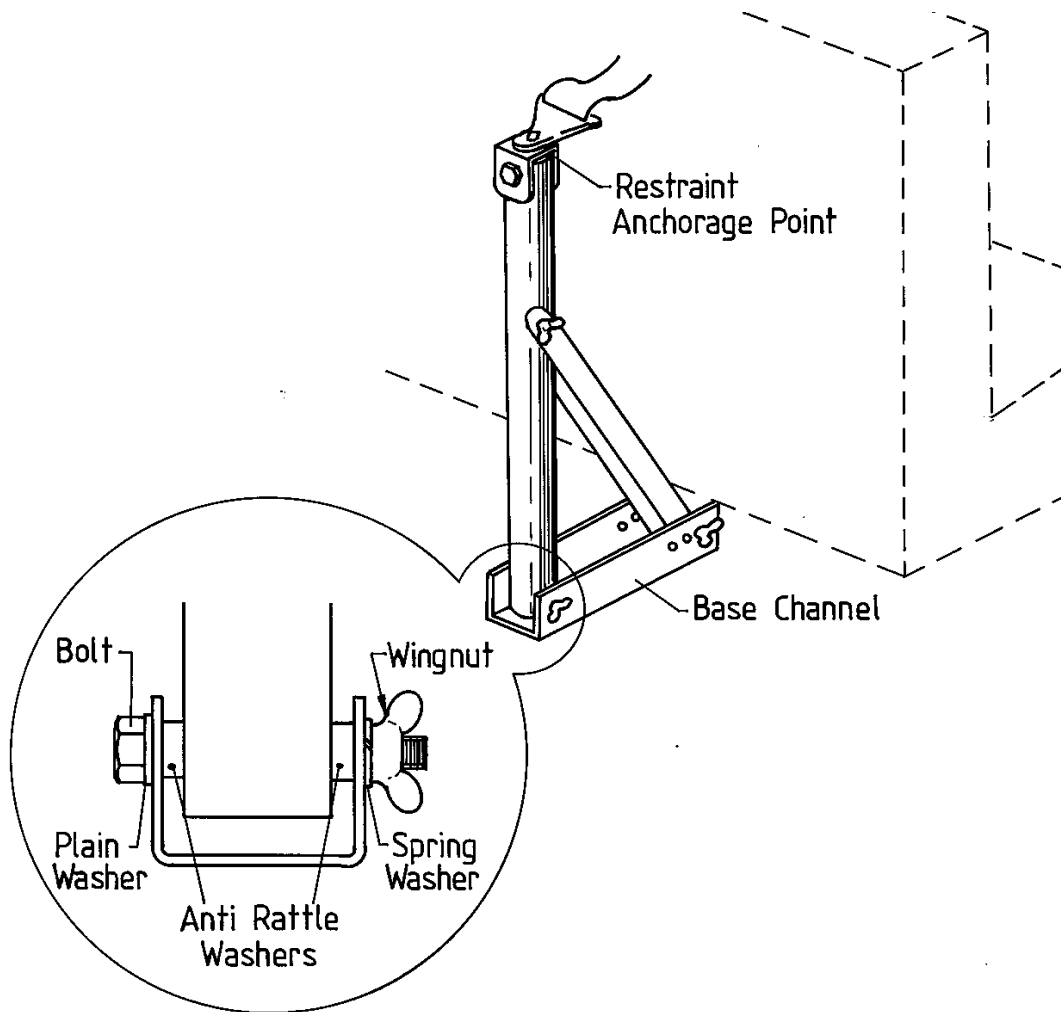

Figure LK10 Vertical Post

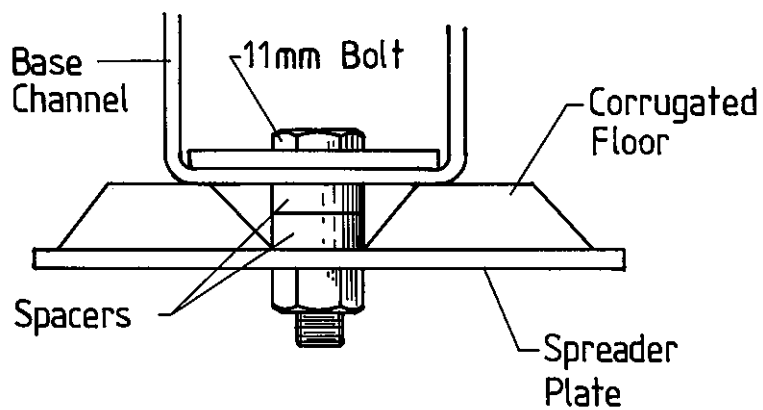

Figure LK11 Vertical Post Attachment

5 UNIVERSAL FRAME

A *Universal Frame* (refer to Figure LK12) has been developed for use in panel vans and station wagons to accommodate all of the presently available child seats.

While it has been designed for installation in the rear of vehicles with a single steel floor pan, it may be possible to install it on vehicles with raised false floors, provided the cavity between the false floor and floor pan can be accessed. The *Universal Frame* must not be used for any purpose other than that for which it was designed.

The *Universal Frame* must be installed in accordance with the manufacturer's fitting instructions and must not be modified in any way.

The frame should be positioned as close as possible behind the front seats to ensure good access to the child restraint and the child, whilst at the same time allowing sufficient space between the vehicle seats and the frame, for the child's legs and feet.

The frame must only be used for child seats and must be installed in the normal forward facing position.

The frame must be secured using high tensile bolts with suitable locking devices such as shake-proof washers.

Spreader plates and spacers to fill in the depth of vee in corrugated floors must be utilised (refer to Figure to LK13).

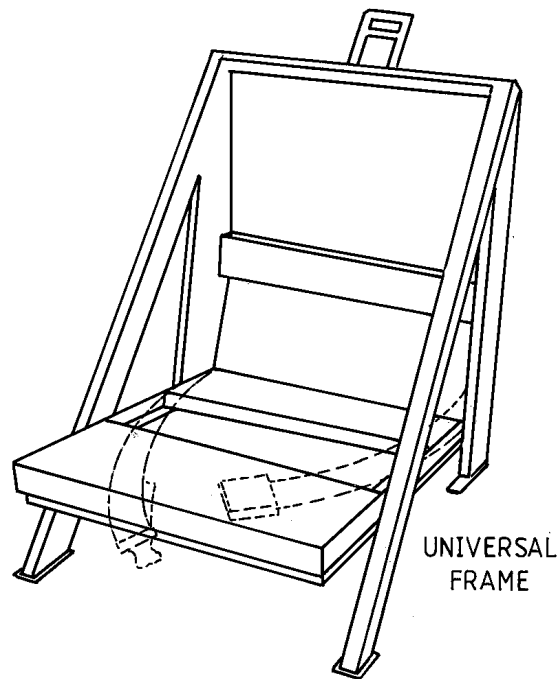

Figure LK12 Universal Frame

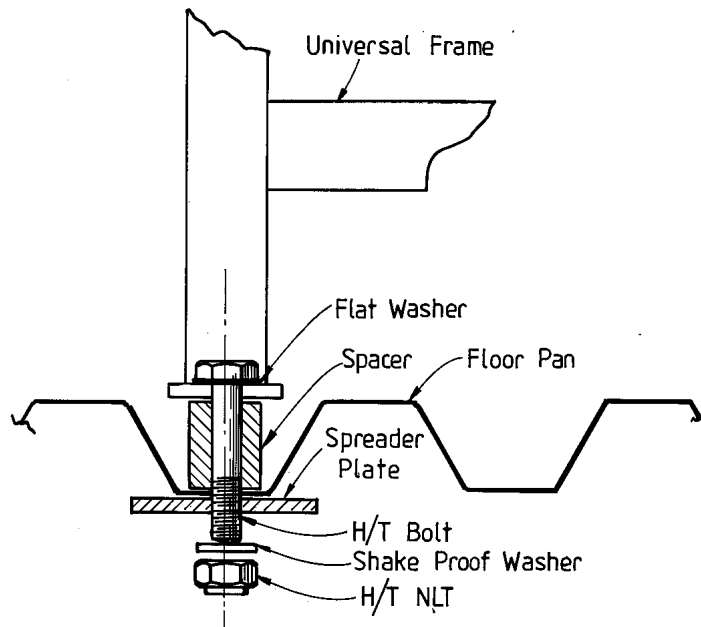

Figure LK13 Universal Frame Attachment

6 DUAL CAB ANCHORAGE

Anchorage for child seats and capsules may be provided in twin cab or dual cab vehicles using a *dual cab anchorage* (DCA) (refer to Figure LK14).

The device may be fitted to any of the rear seat positions providing there is nothing obstructing any spreader plate positions (e.g. fuel tank, lines, chassis rails, etc.).

The device is suitable for use with child seats and safety harnesses.

The twin cab device must be installed in accordance with the manufacturer's instructions and load spreader plates must be utilised.

The centreline of the device must lie within 40mm of the centreline of the child restraint when installed in the required seating position.

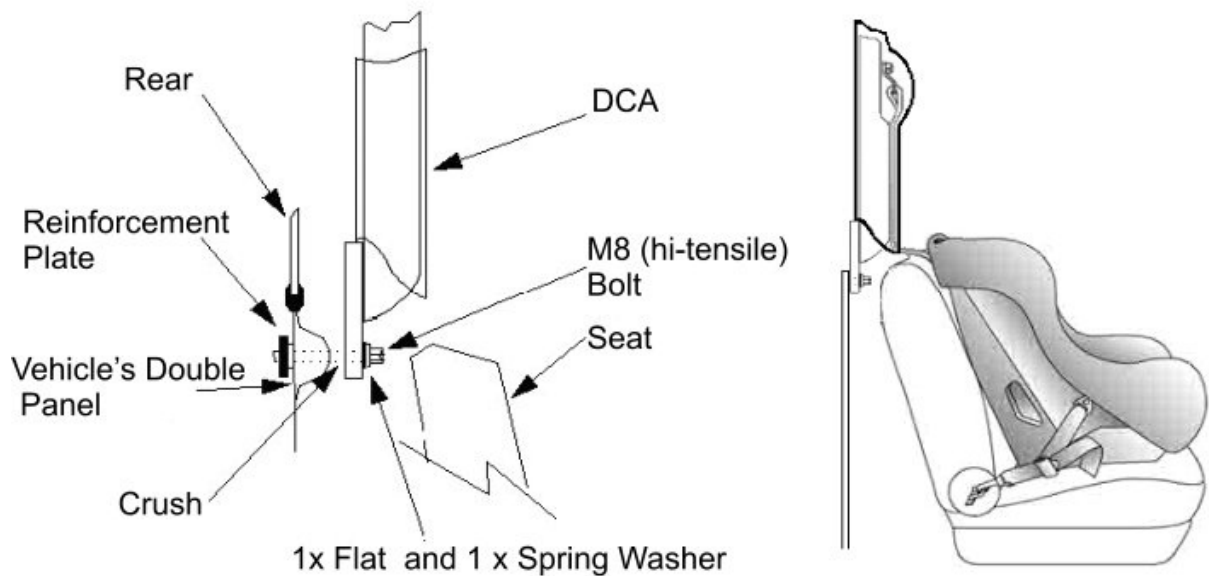

Figure LK14 Dual Cab Anchorage (DCA)

CHECKLIST LK6
CHILD RESTRAINT ANCHORAGE INSTALLATION
CODE LK6

(N/A=Not Applicable, Y=Yes, N=No)

1	INSTALLATION			
1.1	Does the installation comply with the manufacturer's instructions and the relevant sections of Code LK6?		Y	N
1.2	Do the vehicle's seatbelts comply with ADR4, Australian Standards or equivalent?		Y	N
2	WORKMANSHIP			
2.1	Is all work, including welding, of satisfactory quality and has all work been performed in accordance with recognised engineering standards?		Y	N

Note: If the answer to any question is **N (No)**, the modification cannot be certified under Code LK6.

CERTIFICATION DETAILS																	
Make						Model						Year of Manufacture					
VIN																	
Chassis Number (If applicable)																	
Brief Description of Modification/s																	
Vehicle Modified By																	
Certificate Number (If applicable)																	
Vehicle Certified By (<i>Print</i>)																	
Signatory's Employer (If applicable)																	
Signatory's Signature											Date						

CONSTRUCTION AND INSTALLATION OF ONE-OFF ROLL-BARS AND ROLL-CAGES BY INDIVIDUALS

CODE LK8

Code LK8 must be read in conjunction with Appendix LK1 *Supporting Information for Codes LK8, LK9 AND LK10*. Appendix LK1 provides a glossary of terms and examples of roll-over protection structures (ROPS). Code LK8 covers the construction and installation of *roll-bars* and *roll-cages* constructed by individuals.

SCOPE

Code LK8 is intended to assist individuals who wish to construct and install roll-bars or roll-cages for their own use.

Code LK8 covers the construction and installation of one-off *roll-bars* and *roll-cages* that when fitted internally to a vehicle do not compromise the level of safety offered by the vehicle to its passengers.

Code LK8 does not apply to *roll-bars* and *roll-cages* that are produced for the aftermarket.

Code LK8 does not cover *externally mounted roll-bars* or *roll-cages* or ROPS such as those required by the mining industry.

Code LK8 does not apply to ADR Category L-Group vehicles and motor cycles.

MODIFICATIONS COVERED UNDER CODE LK8

The following is a summary of the modifications that may be performed under Code LK8:

- Manufacture and installation of internal four-point roll-bars;
- Manufacture and installation of internal four-point roll-bars in extra cab and dual cab utilities;
- Manufacture and installation of internal six-point roll-bars in station wagons; and
- Manufacture and installation of internal six-point (or more) roll-bars in panel vans and light buses.

MODIFICATIONS NOT COVERED UNDER CODE LK8

Modifications not covered under Code LK8 include:

- Roll-bars, or roll-cages intended for sale as aftermarket products (the design and installation of these devices are covered by Codes LK9 and LK10 in combination);
- ROPS (the design and installation of these devices are covered by Codes LK9 and LK10 in combination);
- Any structure that has a hoop/bar/support or brace along the A pillar;
- Any structure that results in a reduction of the number of passengers the vehicle is designed to carry (this does not apply to vehicles such as rally vehicles that have restrictions or limitations placed on their road use via conditional registration or permits);

- Single hoops without either a rear brace or an upper structural support in convertibles, cabriolets and soft top vehicles;
- External roll-over protection devices of any description;
- Installation of four-point roll-cages, which convert to six-point roll-cages for off-road use; and
- Installation of fixed six-point roll-cages in vehicles other than station wagons, panel vans and light buses.

COMPLIANCE WITH APPLICABLE VEHICLE STANDARDS

Modified vehicles must continue to comply with the ADRs to which they were originally constructed, except as allowed for in the AVSR. These modified vehicles must also comply with the applicable in-service requirements of the AVSR.

Modified pre-ADR vehicles must continue to comply with the AVSR.

Compliance with the AVSR also means compliance with the equivalent regulations of a State or Territory of Australia.

Outlined below in Table LK6 are areas of the vehicle that may be affected by the modifications and that may require re-certification, testing and/or data to show compliance for the modified vehicle. This is not an exhaustive list and other modifications may also affect ADR compliance.

Table LK6 Summary of items that if modified, may detrimentally affect compliance with applicable ADRs

DETAIL	REQUIREMENTS
Installation of Seatbelts and Seatbelt Anchorages	ADR 4x, 4/..., ADR 5x, 5/..., VSB 5
Dangerous internal protrusions	ADR 42/...
Child Restraint Anchorages	ADR 5/..., ADR 34x, 34/..., VSB 5

To determine the ADRs that apply to the vehicle in question, refer to the applicability tables in Section LO. Vehicles manufactured on or after 1 January 1969 and prior to 1 July 1988 need to comply with the Second Edition ADRs, whilst vehicles manufactured after this date need to comply with the Third Edition ADRs. Section LO has separate applicability tables for each edition.

Alternatively, ADR applicability tables for individual vehicle categories may be referenced on the Department of Infrastructure and Transport *RVCS* website at the following address and under the section titled *ADR Applicability Tables*:

<http://rvcs.dotars.gov.au/>

The ADRs apply according to the vehicle’s category and date of manufacture. It is the responsibility of the signatory to refer to the appropriate ADRs applicable to the vehicle.

SPECIFIC REQUIREMENTS

The following are specific requirements for roll-bar and roll-over protection system installations to be certified under Code LK8.

The installations must also comply with the general guidelines contained in sub-section 2 - *General Requirements*.

1 SAFETY

The majority of internal roll-bars or roll-cages were originally designed for use in competition vehicles where the driver and any passengers are required to wear helmets. In normal road use, occupants of motor vehicles do not wear helmets, therefore any modifications to the inside of the cabin must be carefully designed to reduce the risk of injuries to all occupants in the event of a crash.

Six-point roll-cages that have supports running down the *A* pillars and *B* pillars, and braces running to the rear are not acceptable for normal road use as the additional forward supports are likely to constitute an increased injury risk to front seat occupants in a crash. They typically decrease visibility for the driver and usually prevent the correct positioning of sun-visors.

Registration Authorities may allow the use of specialised or six-point roll-cages for competition purposes. However, in these cases, the vehicles to which they are fitted have restricted access to the road system or are conditionally registered. Persons who wish to fit specialised or *six-point* roll-cages for competition or other purposes must consult with their respective Registration Authority for further information. These types of roll-cages are not covered by Code LK8.

2 OCCUPANT PROTECTION AND OCCUPANT REQUIREMENTS

2.1 Access

The roll-bar or roll-cage must not obstruct front seat access nor encroach upon the area occupied by the driver or front seat passenger. Longitudinal braces alongside front seats are therefore not acceptable.

The roll-bar or roll-cage may encroach upon the rear passenger space, but must not obstruct passenger access or the head space (refer to Figure LK15).

2.2 Vehicle Function

The roll-cage must not obstruct the driver in the control of the vehicle.

The roll-bar or roll-cage must not interfere with the normal functioning of any standard or mandatory equipment (e.g. seatbelts, seats and head restraints).

2.3 SRS Side Impact Airbags

Manufacturer's must ensure that, when a roll-bar or roll-cage is designed to suit a vehicle with side curtain/lumbar thoracic air bags, they are aware of the firing squib locations, bag positions and deployment patterns of the air bags and ensure that they are not impeded by the installation of these devices. The roll-bar or roll-cage must also be designed to ensure it does not interfere with the triggering of the air bags during a crash.

2.4 Head Space

No components of the roll-bar or roll-cage may project outside the shaded zone shown in Figure LK15 overleaf. These head space requirements apply to all seating positions.

If the rear braces of the roll-bar or roll-cage lie within the head space for any rear seat passengers then the affected seating position is to be disabled (refer to sub-section 4 of Code LK1) and the vehicle is to be re-certified to the revised seating capacity.

The head space zone requirements of a vehicle can be determined as follows:

- The centre of radius is determined using a 200mm diameter disc, placed on the centre line of the seating position. Measurements are made from point C on the disc with contact point D against the seat back, as shown in Figure LK15;
- Front seat head space limits are determined with the seat in its foremost position (zone limited by windscreen or 45° forward of the vertical) and in the rearmost position (zone limited by 25° rearward of the vertical);
- Rear seat headspace limits are determined by 45° forward and 25° rearward of the vertical. If a seat back angle is adjustable, it must be set at no more than 25° rearward of the vertical; and
- If a seat's height is adjustable, it must be set at the lowest position.

Note:

Any gauge or measuring device utilised for measuring head space requirements must be free standing and not have a gross mass of more than 3 kg when placed in the seating position for measuring purposes.

The top of any gauge utilised for this purpose must have the ability to travel laterally 100mm either side of the centre line of the seating position.

Original vehicle components that intrude into the headspace are not covered by these requirements.

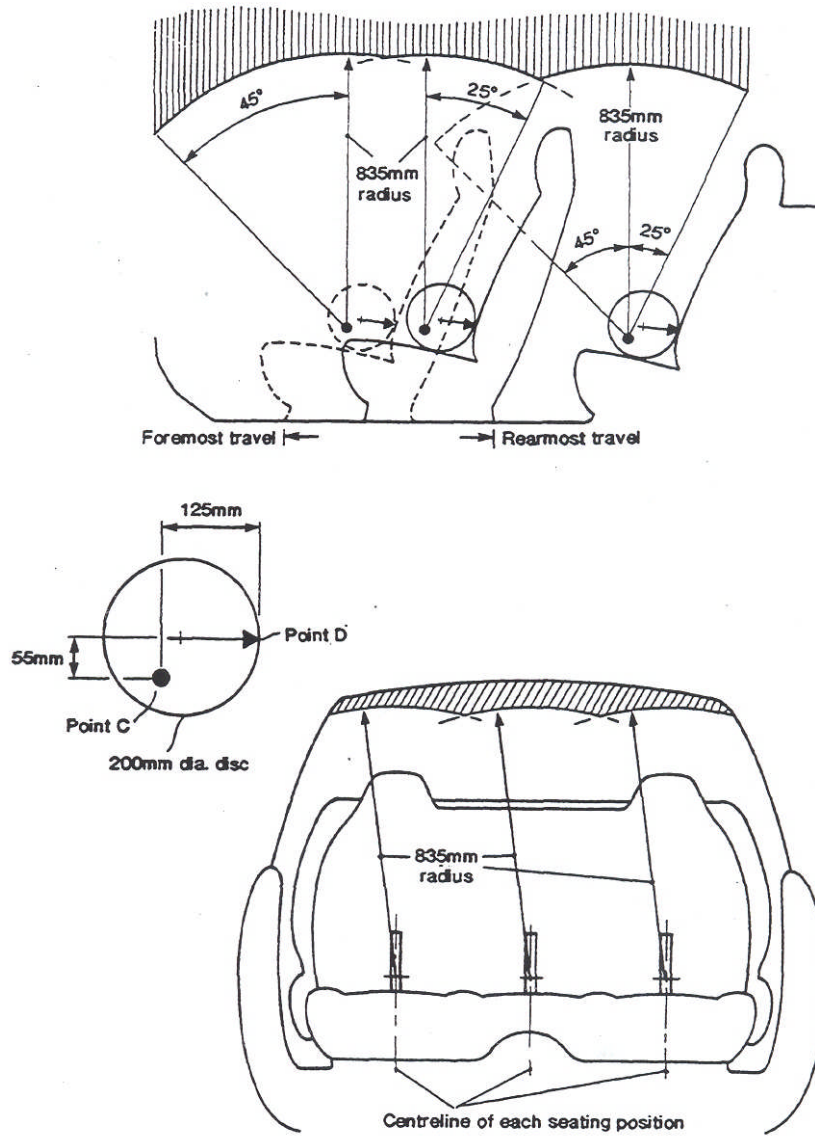
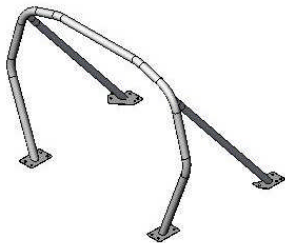

Figure LK15 Head Space Requirements

3 CONFIGURATION

Examples of roll-cages are shown in Figure LK16.



Four-Point Roll-Cage for Cabriolets, Convertibles, Dual Cabs and Utilities

Diagram 1a



Four-Point Roll-Cage for Extra and Dual Cab Utilities

Diagram 1b

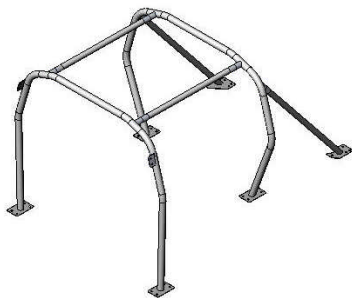

Six-Point Roll-Cage for Station Wagons

Diagram 2a



Six-Point Roll-Cage for Certain Station Wagons and Vans Only

Diagram 2b

Figure LK16 Typical Examples of Roll-Cage Configurations (at or to rear of *B* Pillar)

3.1 Main Hoops

Roll-cages have a hoop that must be placed rearward of the front seat occupants' heads when the seat is in the rearmost position to a maximum distance of 150mm. Each hoop must be built of a single tubular piece, its construction must be without unevenness, cracking, wrinkling or flattening of the tubes. Tube to tube connections must not exist within each hoop.

In closed vehicles, the main hoops must follow as close as practicable the profile of the vehicle's interior so as to minimise the risk of body shell deformation in the event of a vehicle roll-over.

In vehicles converted to convertible/cabriolet body styles, the hoop must be placed no lower than 50mm below the original roofline.

In open vehicles, the occupants' profiles, including shoulders, must be within the hoop when viewed from the front or rear.

Any hole drilled in a main hoop or brace must be fitted with a welded bush, the wall thickness of which must be equal to or greater than the drilled tube.

3.2 Braces and Backstays

Braces and backstays should be straight, where possible. Where braces or backstays with a bend of greater than 20 degrees are required, tubing equivalent in section to the main hoop must be used.

Backstays should extend towards the rear on each side of the vehicle as far as practicable, and be mounted onto the vehicle structure. They must make an angle of at least 30 degrees with the vertical. Backstays should be attached to the upper vertical or horizontal sections of the main hoop.

Single hoops may be attached to the upper section of the *B* or *C* pillar above the seatbelt anchorage point without bracing or backstays. The hoop must not be attached to the seatbelt anchorage unless supported by engineering evidence or testing provided by a suitably qualified and experienced person.

In multi hoop roll-cages, any brace bars that connect the hoops must be as close as possible to the roof line of the vehicle. These brace bars may be out-board of the seating position or run directly over the seatbelt buckle location (i.e. must not be directly over a seating position).

All braces and backstays must be joined with a minimum of two, 10mm diameter (minimum) Grade 8.8, high tensile bolts per joint (refer to Figure LK17).

Where there are no rear passenger seats, a diagonal brace in the plane of the rearmost hoop is recommended.

To attach any brace or back stay to a roll-bar hoop, two 10mm bolts may be used, provided that bushes are welded into the tube to eliminate deformation when the bolts are tightened.

Any welded bush must be of equal or greater wall thickness than that of the tube it is being welded into (refer to Figure LK17).

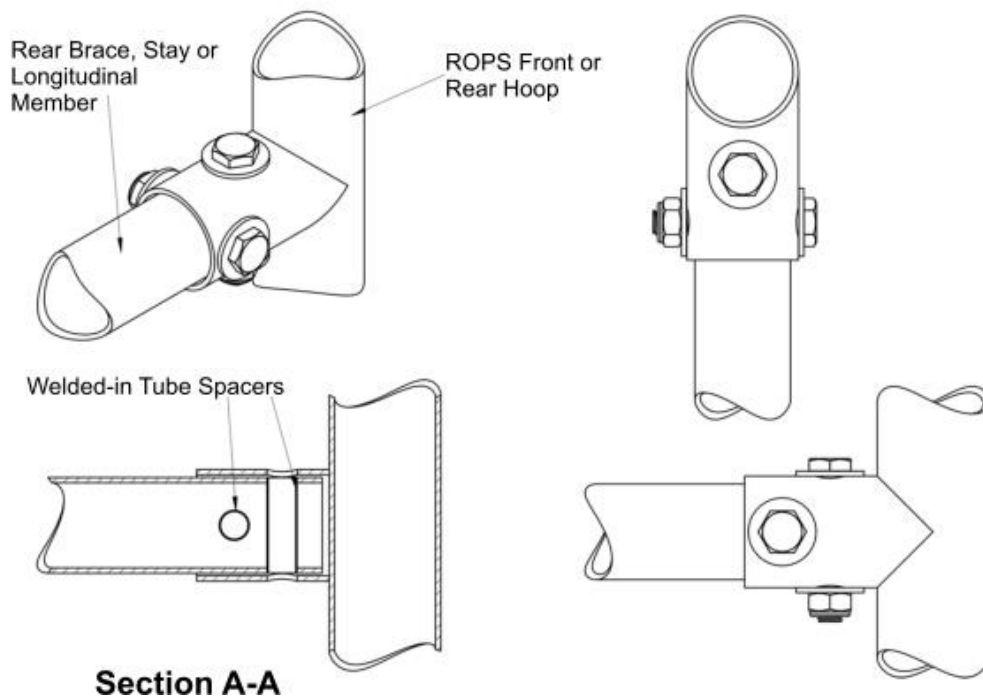

Figure LK17 Tube Joins

3.3 Tube Bending

The tubing must be bent by a cold working process (mandrel bending or drawn over die bending) and have a minimum bend radius of three times the material diameter.

4 ROLL-CAGE MOUNTINGS

4.1 Type of Mounting

Mountings for main hoops and braces should comprise an upper foot mounting plate attached to the roll-over protection system and a lower mounting plate, sandwiching a section of the vehicle's structure between them. These plates must be fixed to the floor of the vehicle as close as possible to the chassis beams or any floor supports/fixing brackets to the chassis. The following requirements outline minimum sizes for mounting plates. Smaller width plates (minimum 45mm wide) may be used provided that the overall area is not reduced.

On four and six point roll-cages (Diagram 1a, 1b, 2a and 2b of Figure LK16), a minimum of two upper mounting tags (one each side) should be attached to one of the main hoops. If an upper pillar captive reinforced mounting has already been provided by the vehicle manufacturer, this should be used if the mounting is designed for a bolt of at least 10mm diameter. Use of the seatbelt mount is discouraged but if the upper torso seatbelt mount is being utilised the roll-over protection system manufacturer must provide an alternate roll-cage mounted tag to relocate the upper belt mount. If this option is utilised, the manufacturer must ensure that the seatbelt still rotates and operates correctly and certification to Code LK2 – Seat and Seatbelt Anchorage is provided.

Where alternate seatbelt anchorage points are utilised, certification of the anchorage point to Code LK1 and LK2 (where necessary) must be carried out. This also requires the cage structure to be

capable of resisting the design loads applied to the seatbelt anchorage points.

4.2 Hollow Section Reinforcement

Where roll-bar or roll-cage mounting bolts pass through a hollow section of the vehicle's structure (e.g. the vehicles floor or pillar), the section must be locally reinforced to prevent crushing (refer to Figure LK18).

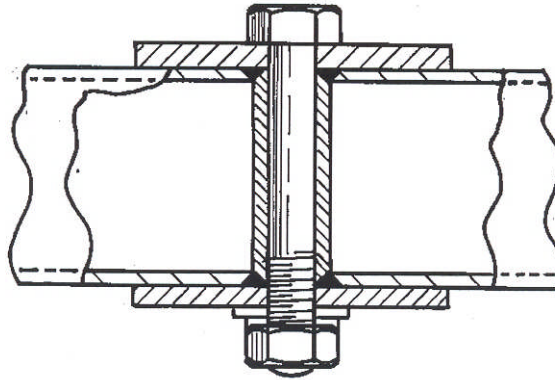

Figure LK18 Reinforcing a hollow section

4.3 Mounting Plates

The mounting plates must be steel and must have a minimum thickness of 3mm and may be as thick as 6mm. Good engineering practices are necessary in selecting the foot plate thickness. In some cases, a square cut 6mm plate can have a guillotine action on the vehicles sheet metal, where a 3mm plate would be more pliable. When selecting plate thickness, consideration needs to be made as to the location of the mounting bolts in proximity to the tubular member. All upper and lower mounting plates used must be of the same thickness.

The main hoop mounting plates must have length times width dimensions of at least:

- 100mm x 75mm for vehicles up to 1150 kg tare mass, or
- 100mm x 100mm for vehicles greater than 1150 kg and up to 1600 kg tare mass; or
- 120mm x 120mm for vehicles greater than 1600 kg tare mass.

The lower underfloor mounting plates must be at least 120mm x 45mm.

Mounting plates of equivalent area may be used.

Mounting plates must be free of sharp edges or protrusions and the mating surface edges must be rounded to reduce the likelihood of any guillotine action occurring.

4.4 Mounting Hardware

High tensile bolts must be used to restrain roll-over protection devices. All mounting hardware and fasteners in general, must comply with the requirements of Section LZ *Appendices, Appendix A Fasteners*.

Where a bolt passes through a tube, the tube must be fitted with a welded spacer/crush

tube of equal material thickness to prevent crushing of the tube as required in sub-section 4.2.

4.5 Typical Roll-Bar and Roll-Cage Mountings

A minimum of three Grade 8.8 high tensile bolts of a minimum 10mm diameter are required at each mounting foot. All holes for fixing bolts must be drilled no nearer to the edge of the full material than the diameter of the hole drilled.

Figure LK19 illustrates typical mounting details that may be utilised for roll-bars and roll-cages fitted to all vehicles.

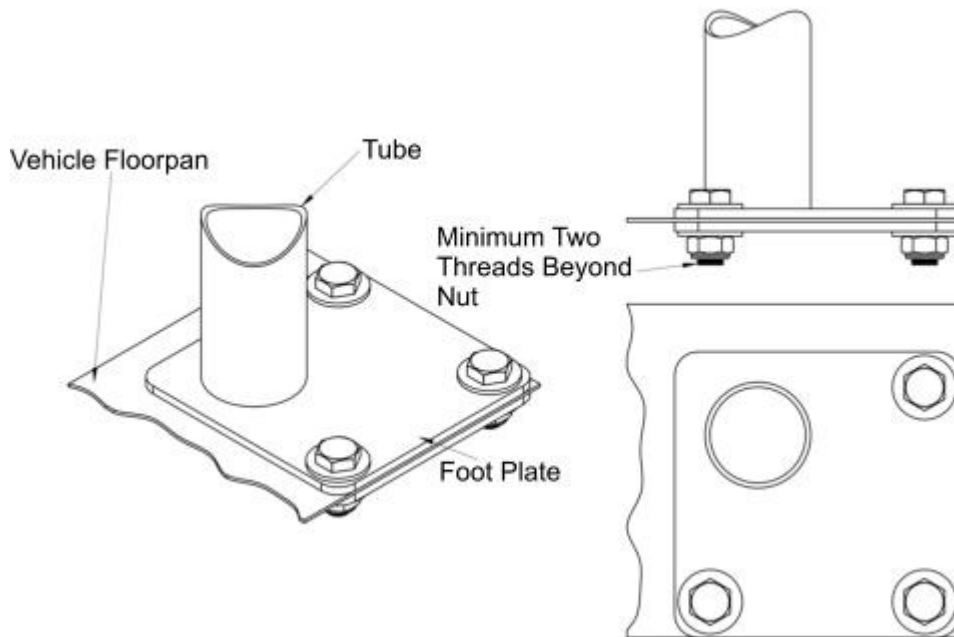

Figure LK19 Roll-Over Protection System Mounting Plates

4.6 General Mounting Guidelines

Modifiers and installers should take into account how open holes and modifications to the body as a result of the installation of a roll-bar or roll-cage will be protected from dust and water penetration.

Modifiers and installers need to be aware of the location of original equipment wiring looms, fuel lines, brake lines and cables (e.g. fuel filler release) to ensure that their designs do not interfere with, damage or in any way adversely affect their proper operation.

Further information and guidance on fasteners is contained in Section LZ *Appendices*, Appendix A *Fasteners*.

5 MATERIAL SPECIFICATIONS

5.1 Tubular Members

All tubular members must be of steel and must meet the minimum specifications listed in Table LK7:

Table LK7 Minimum Dimensions for Tubular Material

Application	Outside Diameter	Wall Thickness
Main Hoops	44.45mm	2.50mm
Braces/Backstays	38.00mm	2.50mm
Braces/Backstays – Bent > 20 Deg	44.45mm	2.50mm

In selecting the steel tube, attention must be paid to obtaining good elongation properties and adequate weldability.

The following materials are not acceptable for use under this code:

- Galvanised pipe or tube; and
- Nominal Bore (NB) black pipe.

5.2 Finish and Corrosion Protection

The entire roll-bar or roll-cage, including mounting plates, should be coated in a rust-prohibitive coating. A powder coat or two pack paint finish is preferable.

6 WELDING

Welds attaching mounting plates and bracing to the main hoop should be full penetration butt welds. This requires bevelling of the tubes to provide the weld preparation.

Welds are not to be ground back. Spot welds must not be used.

For mandatory requirements and guidance on welding techniques and procedures refer to Appendix C *Heating and Welding of Steering Components* in Section LZ *Appendices*.

7 PADDING REQUIREMENTS

All sections of the roll-bar or roll-cage in the passenger area that lie within the defined head space area (refer to sub-section 2 of Code LK8 and figure LK15) between 710mm and 835mm or which are 150mm or less from an occupants head must be covered by padding that meets the padding specifications detailed in Appendix B *Foam Padding for Occupant Protection* in Section LZ *Appendices*.

Hollow pipe insulation or foams typically used for upholstery work are not acceptable for occupant protection padding.

8 SEATBELT ANCHORAGES

Upper torso seatbelt anchorages may be incorporated in the vertical sections of the main hoop. Where the anchorage bolt passes through a hollow section it must be locally reinforced as detailed in Figure LK18 and must be certified to comply with Code LK2.

Where alternate seatbelt anchorage points are utilised, certification of the anchorage point to Code LK2 must be carried out.

Alternate mounting points may be utilised to anchor the hoops at both *B* and *C* pillars but must not interfere with the correct operation of the seatbelt.

In the case where a roof modification results in no suitable structure for the seatbelt upper anchorage points, a suitably designed roll-bar must be fitted to accommodate the upper anchorage points. Certification of the anchorage point to Code LK2 must be carried out.

CHECKLIST LK8

CONSTRUCTION AND INSTALLATION OF ONE-OFF
ROLL-BARS AND ROLL-CAGES BY INDIVIDUALS

CODE LK8

(N/A=Not Applicable, Y=Yes, N=No)

1.	CONFIGURATION			
1.1	Is the central hoop correctly shaped and positioned?		Y	N
1.2	Is the seat access unobstructed, is adequate driver and passenger space retained and are headspace requirements met?		Y	N
1.3	Are there sufficient support points?		Y	N
1.4	Are all body components properly fabricated?		Y	N
1.5	Does any part of the installation not interfere with the use of seatbelts, head restraints or with the operation or deployment of air bags?		Y	N
1.6	Are any additional or replacement mechanical components certified (where necessary) under the appropriate codes of VSB 14?	N/A	Y	N
2.	MOUNTINGS			
2.1	Are all mounting plates the correct size and thickness?		Y	N
2.2	Are at least three (3) 10mm Grade 8.8 high tensile bolts (or equivalent) and self locking nuts used at each mounting point?		Y	N
2.3	Are hollow mounting points correctly reinforced at mounting points?	N/A	Y	N
3.	TUBING			
3.1	Is tubing, including bent braces, of the correct size and material?		Y	N
3.2	Is tubing correctly padded where required?	N/A	Y	N
3.3	Is Padding used of acceptable quality and density? Does the padding used comply with the requirements specified in Appendix B <i>Foam Padding for Occupant Protection</i> in Section LZ <i>Appendices</i> ?	N/A	Y	N

[Continued overleaf]

(N/A=Not Applicable, Y=Yes, N=No)

3.4	Where seatbelt anchor points are attached to tubing, is the tubing of sufficient strength to carry the design loads?	N/A	Y	N
4.	WORKMANSHIP			
4.1	Is all work, including welding, of satisfactory quality and has all work been performed in accordance with recognised engineering standards?		Y	N
4.2	Do all new or replaced fasteners comply with the applicable requirements of Section LZ <i>Appendices, Appendix A Fasteners</i> ?	N/A	Y	N
4.3	Does the quality of welding comply with the applicable requirements of Section LZ <i>Appendices, Appendix C Heating and Welding of Steering Components</i> ?	N/A	Y	N
5	LOAD CARRYING CAPACITY			
5.1	Has the installation of the roll-over protection device not exceeded the load carrying capacity of the vehicle?	N/A	Y	N

Note: If the answer to any question is **N (No)**, the modification cannot be certified under Code LK8.

CERTIFICATION DETAILS																
Make			Model				Year of Manufacture									
VIN																
Chassis Number (If applicable)																
Brief Description of Modification/s																
Vehicle Modified By																
Certificate Number (If applicable)																
Vehicle Certified By (<i>Print</i>)																
Signatory's Employer (If applicable)																
Signatory's Signature							Date									

DESIGN AND MANUFACTURE OF COMMERCIAL AFTERMARKET ROLL-BARS, ROLL-CAGES AND OTHER TYPES OF ROPS

CODE LK9

Code LK9 must be read in conjunction with Appendix LK1 *Supporting Information for Codes LK8, LK9 AND LK10*. Appendix LK1 provides a glossary of terms and examples of roll-over protection devices.

SCOPE

Code LK9 covers the design of roll-bars, roll-cages and *roll-over protection structures* (ROPS) that when fitted internally to a vehicle, do not compromise the level of safety offered by the vehicle to its passengers. Code LK9 and LK 10 are intended for use by manufacturers and installers of roll-over protection devices.

Code LK9 covers the vehicle occupant protection safety issues concerning the installation of these devices – it does not cover the *performance requirements* of these devices.

Code LK9 applies only to roll-bars, roll-cages and ROPS that are made under a production basis either for installation in fleet vehicles or other vehicles and that have had their *performance requirements* designed by suitably qualified and experienced personnel. A copy of the *performance requirements* must be retained by the ROPS manufacturer for audit purposes.

Code LK9 does not cover externally mounted roll-cages or ROPS.

Code LK9 does not apply to ADR Category L-Group vehicles and motor cycles.

DESIGNS COVERED UNDER CODE LK9

The following is a summary of the modifications that may be designed under Code LK9:

- Any internally mounted, roll-bar, roll-cage or ROPS; and
- Any other ROPS that may be required by legislation.

DESIGNS NOT COVERED UNDER CODE LK9

Code LK9 does not cover:

- Any roll-bar, roll-cage or ROPS that is externally mounted.

COMPLIANCE WITH APPLICABLE VEHICLE STANDARDS

Modified vehicles must continue to comply with the ADRs to which they were originally constructed, except as allowed for in the AVSR. These modified vehicles must also comply with the applicable in-service requirements of the AVSR.

Modified pre-ADR vehicles must continue to comply with the AVSR.

Compliance with the AVSR also means compliance with the equivalent regulations of a State or Territory of Australia.

Outlined below in Table LK8 are areas of the vehicle that may be affected by the modifications and that may require re-certification, testing and/or data to show compliance for the modified vehicle. This is not an exhaustive list and other modifications may also affect ADR compliance.

Table LK8 Summary of items that if modified, may detrimentally affect compliance with applicable ADRs

DETAIL	REQUIREMENTS
Installation of Seatbelts and Seatbelt Anchorages	ADR 4x, 4/..., ADR 5x, 5/..., VSB 5
Dangerous internal protrusions	ADR 42/...
Child Restraint Anchorages	ADR 5/..., ADR 34x, 34/..., VSB 5

To determine the ADRs that apply to the vehicle in question, refer to the applicability tables in Section LO. Vehicles manufactured on or after 1 January 1969 and prior to 1 July 1988 need to comply with the Second Edition ADRs, whilst vehicles manufactured after this date need to comply with the Third Edition ADRs. Section LO has separate applicability tables for each edition.

Alternatively, ADR applicability tables for individual vehicle categories may be referenced on the Department of Infrastructure and Transport *RVCS* website at the following address and under the section titled *ADR Applicability Tables*:

<http://rvcs.dotars.gov.au/>

The ADRs apply according to the vehicle's category and date of manufacture. It is the responsibility of the signatory to refer to the appropriate ADRs applicable to the vehicle.

SPECIFIC REQUIREMENTS

The following are specific requirements for roll-bars, roll-cages and ROPS installations to be processed under Code LK9.

The installations must also comply with the general guidelines contained in sub-section 2 - *General Requirements*.

1 OCCUPANT SAFETY REQUIREMENTS

1.1 Access

The roll-over protection structure must not obstruct front seat access nor encroach upon the area occupied by the driver or front seat passenger. Longitudinal braces must not be located alongside front seats.

The roll-over protection structure may encroach upon the rear passenger space, but must not obstruct passenger access or the head space (refer to Figure LK15).

1.2 Vehicle Function

The roll-over protection structure must not obstruct the driver in the control of the vehicle.

The roll-over protection structure after installation must not interfere with the normal functioning of any standard or mandatory equipment such as seatbelts, seats, head restraints and airbags.

1.3 SRS Side Impact Airbags

The design of roll-bars, roll-cages or ROPS must ensure that when these devices are fitted to vehicles with side air bags, they do not interfere with the operation of these safety devices. The firing squib locations, bag positions and deployment patterns of the air bags are parameters that must be considered and addressed in the design. The roll-over protection system must also be designed to ensure it does not interfere with the triggering of the air bags during a crash.

Where a roll-over protection system is designed for a vehicle that has side curtain/lumbar thoracic air bags as standard or available as an option in the model range, it is the responsibility of the roll-over protection system manufacturer to advise, as part of the fitting instructions (refer to subsection 9 of this Code LK9) and noted on the certification plate, whether the roll-over protection system *is or is not compatible* with the side impact air bags. This is to reduce the likelihood of a system that is not compatible with air bags being fitted to a vehicle equipped with these devices.

1.4 Head Space

No components of the roll-over protection system device may project outside the shaded zone shown in Figure LK15. These head space requirements apply to all seating positions.

If the rear braces of the roll-over protection system device lie within the head space for any rear seat passengers then the affected seating position is to be disabled (refer to Section 9 of this code) and the vehicle is to be re-certified to the revised seating capacity.

The head space zone requirements of a vehicle can be determined as follows:

- The centre of radius is determined using a 200mm diameter disc, placed on the centre line of the seating position. Measurements are made from point C on the disc with contact point D against the seat back, as shown in Figure LK15;
- Front seat head space limits are determined with the seat in its foremost position (zone limited by windscreen or 45° forward of the vertical) and in the rearmost position (zone limited by 25° rearward of the vertical);
- Rear seat headspace limits are determined by 45° forward and 25° rearward of the vertical. If a seat back angle is adjustable, it must be set at no more than 25° rearward of the vertical; and

- If a seat's height is adjustable, it must be set at the lowest position.

Note: Any gauge or measuring device utilised for measuring head space requirements must be free standing and not have a gross mass of more than 3 kg when placed in the seating position for measuring purposes.

The top of any gauge utilised for this purpose must have the ability to travel laterally 100mm either side of the centre line of the seating position.

Original vehicle components that intrude into the headspace are not covered by these requirements.

3 CONFIGURATION

3.1 Main Hoops

Roll-over protection system structures have a hoop that must be placed rearward of the front seat occupants' heads when the seat is in the rearmost position to a maximum distance of 150mm.

In closed vehicles, the main hoops must follow as close as practicable the profile of the vehicle's interior so as to minimise the risk of body shell deformation in the event of a vehicle roll-over.

3.2 Tube Bending

The tubing must be bent by a cold working process (mandrel bending or drawn over die bending) and have a minimum bend radius of three times the material diameter.

3.3 General Mounting Guidelines

In the preparation of the *performance requirements* design, designers should ensure that holes and modifications to the body, as a result of the installation of the roll-over protection system, are adequately protected from dust and water penetration.

Designers also need to be aware of the location and routing of original equipment electrical wiring, fuel lines, brake lines and cables (e.g. fuel filler release) and ensure that their design does not interfere, damage or in any way adversely affect the operation of any of these items.

4 WELDING

For mandatory requirements and guidance on welding techniques and procedures refer to Appendix C *Heating and Welding of Steering Components* in Section LZ *Appendices*.

5 PADDING REQUIREMENTS

All sections of the roll-over protection system in the passenger area that lie within the defined head space area (refer to sub-section 2 of Code LK8 and figure LK15) between 710mm and 835mm or which are 150mm or less from an occupants head must be covered by padding that meets the padding specifications detailed in Appendix B *Foam Padding for Occupant Protection* in Section LZ *Appendices*.

Hollow pipe insulation or foams typically used for upholstery work are not acceptable for occupant protection padding.

6 SEATBELT ANCHORAGES

Upper torso seatbelt anchorages may be incorporated in the vertical sections of a hoop. Where the anchorage bolt passes through a hollow section it must be locally reinforced as detailed in Figure LK17 and must be certified to comply with Code LK2.

Where alternate seatbelt anchorage points are utilised, certification of the anchorage point to Code LK2 must be carried out.

Alternate mounting points may be utilised to anchor the hoops at both *B* and *C* pillars but must not interfere with the correct operation of the seatbelt.

7 SEATING CAPACITY REDUCTION

Where the installation of a roll-over protection system interferes with occupant seating positions (e.g. Third row seating in a wagon) a seating reduction certification must be carried out (refer to Code LK1 – Seat and Seatbelt Installation/Removal).

In the situation where a seating reduction is necessary (i.e. a wagon being reduced from 7 seats to 5 seats) the affected seats and seatbelts must be removed. However, where the removal of the seat is not possible (i.e. in a dual cab where the rear central seating position needs to be removed due to head space requirements), the seatbelts are to be removed and a decal is to be placed in a conspicuous position stating, for example:

THIS VEHICLE HAS BEEN REGISTERED AS A 4 SEATER. THE CENTRE REAR SEATING POSITION IS NO LONGER USEABLE.

8 COMPLIANCE AND DECALS

The roll-over protection structure must have a permanently attached manufacturer's identification plate containing the following information:

- Manufacturer's Name;
- Part Number;
- Serial Number; and
- *SRS Compliant* or *SRS Not Compliant*.

Warning decals must be conspicuous and state:

SHOULD THIS ROLL-OVER PROTECTION SYSTEM BE INVOLVED IN AN ACCIDENT OR ROLL-OVER, THE REGISTERED OWNER SHOULD HAVE IT INSPECTED IMMEDIATELY.

DO NOT DRILL, WELD OR MODIFY.

SEATBELTS MUST BE WORN AT ALL TIMES.

9 FITTING INSTRUCTIONS

If the roll-over protection structure is marketed as an aftermarket accessory product for owner installation, the structure must be provided with fitting instructions by its manufacturer. The instructions must include the following:

- Manufacturer's name;
- Part Number;
- Vehicle Make, Model, Body Shape and Year Range that the roll-over protection system is suitable for;
- Information as to whether the structure is compatible with airbags. If the structure is compatible with airbags any installation issues that might affect the correct deployment of airbags must be clearly detailed;
- Whether a seating capacity reduction is required;
- Parts Inventory; and
- Detailed step by step fitting instructions.

10 RECORD AND DOCUMENTATION

The authorised manufacturer must hold copies of all drawings, specifications, test results, mill certificates and any other data necessary to fully describe both the ROP system and the modifications necessary to install it in the vehicle or vehicles for which it is intended.

CHECKLIST LK9

DESIGN AND MANUFACTURE OF COMMERCIAL AFTERMARKET ROLL-BARS,
ROLL-CAGES AND OTHER TYPES OF ROPS

CODE LK9

(N/A=Not Applicable, Y=Yes, N=No)

1.	Performance Design			
1.1	Does the roll-over protection device have a <i>performance requirements</i> design?		Y	N
1.2	<i>Performance requirements</i> design identification		
2	CONFIGURATION			
2.1	Has the designer ensured that seat access is not obstructed, that there is adequate driver and passenger space and that all headspace requirements have been met?		Y	N
2.2	Has the proposed installation been designed so as not to interfere with the correct use of seatbelts or with the operation or deployment of air bags?		Y	N
2.3	Are any additional or replacement mechanical components certified (where necessary) under the appropriate codes of VSB 14?	N/A	Y	N
3.	MOUNTINGS			
3.1	Are all the dimensions of mounting plates specified in the <i>performance requirements</i> design?		Y	N
3.2	Are the size, number and grade of bolts specified in the <i>performance requirements</i> design and are the locations of locking nuts specified?		Y	N
3.2	Does the <i>performance requirements</i> design provide sufficient information as to how hollow mounting points are to be reinforced?	N/A	Y	N
4.	TUBING			
4.1	Have the dimensions and material specifications of all tubing been specified?		Y	N
4.2	Has the design provided for padding in the required areas?		Y	N

[Continued overleaf]

(N/A=Not Applicable, Y=Yes, N=No)

4.3	Does the padding specified comply with the requirements specified in Appendix B <i>Foam Padding for Occupant Protection</i> in Section LZ <i>Appendices</i> ?	N/A	Y	N
4.4	Where seatbelt anchor points are attached to tubing, is the tubing of sufficient strength to carry the design loads and have the anchor points been certified to Code LK2?	N/A	Y	N
5.	WORKMANSHIP			
5.1	Has all work, including welding, that has been specified in the certification to LK9 design and in the <i>performance requirements</i> design been designed and specified in accordance with recognised engineering standards and the relevant <i>Appendices</i> of Section LZ <i>Appendices</i> ?		Y	N
6	LOAD CARRYING CAPACITY			
6.1	Does the design of the roll-over protection device take into account the load carrying capacity of the vehicle?	N/A	Y	N
7	RECORDS			
7.1	Have records been kept of all drawings, specifications, test results and any other data necessary to fully describe both the roll-over protection device and the modifications necessary to install it in the vehicle or vehicles for which it is intended.		Y	N

Note: If the answer to any question is **N (No)**, the modification cannot be certified under this Code LK9.

[Continued overleaf]

CERTIFICATION DETAILS																
Make						Model						Year of Manufacture				
VIN																
Chassis Number (If applicable)																
Brief Description of Modification/s																
Vehicle Modified By																
Certificate Number (If applicable)																
Vehicle Certified By (<i>Print</i>)																
Signatory's Employer (If applicable)																
Signatory's Signature											Date					

INSTALLATION OF AFTERMARKET ROLL-BARS, ROLL-CAGES AND ROPS

CODE LK10

Code LK10 must be read in conjunction with Appendix LK1 *Supporting Information for Codes LK8, LK9 AND LK10*. Appendix LK1 provides a glossary of terms and examples of roll-over protection devices.

SCOPE

Code LK10 covers the installation of roll-bars, roll-cages and ROPS that when fitted to a vehicle do not compromise the level of safety offered by the vehicle to its passengers. Code LK9 and LK10 are intended for use by manufacturers and installers of roll-over protection devices.

Code LK10 covers the vehicle occupant protection safety issues to do with the installation of these devices.

Installations to Code LK10 may only be performed by utilizing roll-bars, roll-cages and ROPS that have:

- A Code LK9 design; and
- A *performance requirements* design.

Code LK10 does not cover *externally mounted* roll-cages or ROPS.

Code LK10 does not apply to ADR Category L-Group vehicles and motor cycles.

INSTALLATIONS COVERED UNDER CODE LK10

The following is a summary of the installations that are covered under Code LK10:

- Any internally mounted, roll-bar, roll-cage or ROPS that has a Code LK9 design approved by a Registration Authority; and
- Any other ROPS that may be required by legislation and has a Code LK9 design approved by a Registration Authority.

INSTALLATIONS NOT COVERED UNDER CODE LK10

Code LK10 does not cover:

- Any roll-bar, roll-cage or ROPS that does not have a Code LK9 design approval from a Registration Authority;
- The design of a roll-bar, roll-cage or ROPS. (Designs are covered by LK9); and
- One-off roll-bars and roll-cages. (These are covered by LK8).

COMPLIANCE WITH APPLICABLE VEHICLE STANDARDS

Modified vehicles must continue to comply with the ADRs to which they were originally constructed, except as allowed for in the AVSR. These modified vehicles must also comply with the applicable in-service requirements of the AVSR.

Modified pre-ADR vehicles must continue to comply with the AVSR.

Compliance with the AVSR also means compliance with the equivalent regulations of a State or Territory of Australia.

SPECIFIC REQUIREMENTS

The following are specific requirements for roll-cages and ROP system installations to be processed under Code LK10.

The installations must also comply with the general guidelines contained in sub-section 2 - *General Requirements*.

1 DESIGN

Installations to Code LK10 may only be performed by utilizing roll-bars, roll-cages and ROPS that have a Code LK9 design approved by a Registration Authority, and the completed and installed roll-bar must be constructed and fitted in accordance with the specifications detailed in the Code LK9 design.

2 ACCESS

When fitted, the roll-over protection structure must not obstruct front seat access nor encroach upon the area occupied by the driver or front seat passenger. Horizontal braces alongside front seats are not acceptable.

The roll-over protection structure may encroach upon the rear passenger space, but must not obstruct passenger access or the head space (refer to Figure LK15).

3 VEHICLE FUNCTION

When fitted, the roll-over protection structure must not obstruct the driver in the control of the vehicle. It must also not interfere with the normal functioning of any standard or mandatory equipment such as seatbelts, seats, head restraints and airbags.

4 HEAD SPACE

No components of the roll-over protection system structure installation may project outside the shaded zone shown in Figure LK15. These head space requirements apply to all seating positions.

If the rear braces of the roll-over protection system structure design lie within the head space for any rear seat passengers then the affected seating position is to be disabled and the vehicle is to be re-certified to the revised seating capacity (refer to sub-clause Clause 7).

5 PADDING REQUIREMENTS

All components of the roll-over protection device in the passenger area that lie within the defined head space area (refer to sub-section 2 of Code LK8 and figure LK15) between 710mm and 835mm or which are 150mm or less from an occupants head must be covered by padding that meets the padding specifications detailed in Appendix B *Foam Padding for Occupant Protection* in Section LZ *Appendices*.

Hollow pipe insulation or foams typically used for upholstery work are not acceptable for occupant protection padding.

6 SEATBELT ANCHORAGES

Upper torso seatbelt anchorages may be incorporated in the vertical sections of a hoop. Where the anchorage bolt passes through a hollow section it must be locally reinforced as detailed in Figure LK17 and must be certified to comply with Code LK2.

Where alternate seatbelt anchorage points are utilised, certification of the anchorage point to Code LK2 must be carried out.

Alternate mounting points may be utilised to anchor the hoops at both *B* and *C* pillars but must not interfere with the correct operation of the seatbelt.

7 SEATING CAPACITY REDUCTION

Where the installation of a roll-over protection structure interferes with occupant seating positions (e.g. Third row seating in a wagon) the seats must be removed (refer to Code LK1 – Seat and Seatbelt Installation/Removal and to the requirements of the Registration Authority in which the vehicle is be used).

In the situation where a seating reduction is necessary (i.e. a wagon being reduced from 7 seats to 5 seats) the affected seats and seatbelts must be removed. However, where the removal of the seat is not possible (i.e. in a dual cab where the rear central seating position needs to be removed due to head space requirements), the seatbelts are to be removed and a decal is to be placed in a conspicuous position stating, for example:

THIS VEHICLE HAS BEEN REGISTERED AS A 4 SEATER. THE CENTRE REAR SEATING POSITION IS NO LONGER USEABLE.

8 COMPLIANCE AND DECALS

The roll-over protection structure must have a permanently attached manufacturer's identification plate containing the following information:

- Manufacturer's Name;
- Part Number;
- Serial Number; and
- SRS Compliant or SRS Not Compliant.

Warning decals must be conspicuous and state:

SHOULD THIS ROLL-OVER PROTECTION SYSTEM BE INVOLVED IN AN ACCIDENT OR ROLL-OVER, THE REGISTERED OWNER SHOULD HAVE IT INSPECTED IMMEDIATELY.

DO NOT DRILL, WELD OR MODIFY.

SEATBELTS MUST BE WORN AT ALL TIMES.

9 FITTING INSTRUCTIONS

If the roll-over protection structure is marketed as an aftermarket accessory product for owner installation, the structure must be provided with fitting instructions by its manufacturer. The instructions must include the following:

- Manufacturer's name;
- Part Number;
- Vehicle Make, Model, Body Shape and Year Range that the roll-over protection system is suitable for;
- Information as to whether the structure is compatible with airbags. If the structure is compatible with airbags any installation issues that might affect the correct deployment of airbags must be clearly detailed;
- Whether a seating capacity reduction is required;
- Parts Inventory; and
- Detailed step by step fitting instructions.

10 RECORDS AND DOCUMENTATION

The authorised manufacturer must hold copies of all drawings, specifications, test results, mill certificates and any other data necessary to fully describe both the ROP system and the modifications necessary to install it in the vehicle or vehicles for which it is intended.

CHECKLIST LK10

**INSTALLATION OF AFTERMARKET ROLL-BARS,
ROLL-CAGES AND ROPS**

CODE LK10

(N/A=Not Applicable, Y=Yes, N=No)

1.	DESIGN		
1.1	Has the roll-bar, roll-cage or ROPS been built to a <i>performance requirements</i> design?		Y N
1.2	<i>Performance requirements</i> design identification.....		
1.3	Has the roll-bar, roll-cage or ROPS been built to a Code LK9 design?		Y N
1.4	Code LK9 Design Approval No (where applicable).....		
2.	CONFIGURATION		
2.1	Is the seat access unobstructed, is adequate driver and passenger space retained and are headspace requirements met?		Y N
2.2	Are there sufficient support points as specified in the <i>performance requirements</i> device design?		Y N
2.3	Does any part of the installation not interfere with the correct use of seatbelts, head restraints or with the operation or deployment of air bags?		Y N
2.4	Is any additional or replacement work certified (where necessary) under the appropriate Sections and codes of VSB 14?	N/A	Y N
3.	MOUNTINGS		
3.1	Are all mounting plate dimensions as specified in the <i>performance requirements</i> design?		Y N
3.2	Are hollow mounting points reinforced at mounting points as specified in the device <i>performance requirements</i> design?	N/A	Y N
4.	TUBING AND PADDING		
4.1	Is tubing, including bent braces, of the size and material as specified in the <i>performance requirements</i> design?		Y N
4.2	Is tubing padded where required?	N/A	Y N

[Continued overleaf]

(N/A=Not Applicable, Y=Yes, N=No)

4.3	Does all padding comply with the specifications for padding as required in Appendix B <i>Foam Padding for Occupant Protection</i> of Section LZ <i>Appendices</i> ?		Y	N
4.4	Where seatbelt anchor points are attached to tubing, is the tubing of sufficient strength to carry the design loads?		Y	N
5.	WORKMANSHIP			
5.1	Is all work, including welding, of satisfactory quality and has all work been performed in accordance with recognised engineering standards?		Y	N
5.2	Do all new or replaced fasteners comply with the applicable requirements of Appendix A <i>Fasteners</i> in Section LZ <i>Appendices</i> ?	N/A	Y	N
5.3	Does the quality of welding comply with the applicable requirements of Appendix C <i>Heating and Welding of Steering Components</i> in Section LZ <i>Appendices</i> ?	N/A	Y	N
6	COMPLIANCE AND WARNING DECALS			
6.1	Does the roll-over protection structure have a permanently attached manufacturer's identification plate containing the information required in Clause 8?		Y	N
6.2	Are decals complete with appropriate wording displayed in a conspicuous location as required by Clause 7 and or Clause 8?		Y	N
6.3	<u>For aftermarket products:</u> Are fitting instructions provided as required in Clause 9?	N/A	Y	N
7	LOAD CARRYING CAPACITY			
7.1	Has the installation of the roll-over protection device taken into account the load carrying capacity of the vehicle, including the mass of the structure and the mass allowances for passengers and luggage?		Y	N
7.2	Has the ADR vehicle category of the vehicle remained the same as a result of the installation?	N/A	Y	N

[Continued overleaf]

Note: If the answer to any question is **N (No)**, the modification cannot be certified under this Code LK10.

CERTIFICATION DETAILS																	
Make							Model							Year of Manufacture			
VIN																	
Chassis Number (If applicable)																	
Brief Description of Modification/s																	
Vehicle Modified By																	
Certificate Number (If applicable)																	
Vehicle Certified By (<i>Print</i>)																	
Signatory's Employer (If applicable)																	
Signatory's Signature												Date					

APPENDIX LK1 SUPPORTING INFORMATION FOR CODES LK8, LK9 AND LK10

The following information and terms apply to Codes LK8, LK9 and LK10.

LIMITED APPLICATION

Registration Authorities do not generally allow roll-cages and ROPS devices to be fitted to registered vehicles. Dispensation is allowed for vehicles that are used for specific purposes such as rescue vehicles, vehicles used on mine sites, and certain rally and other competition vehicles.

Registration Authorities control the use of these vehicles on public roads by various means including conditional registration or by the issue of permits.

To ensure a vehicle is eligible to be fitted with a roll-cage or ROP device, contact the Registration Authority that is responsible for the area in which the vehicle is intended to be used before performing any modifications under these codes.

While Code LK9 provides a great deal of flexibility on the design of roll-over protection devices, it does not guarantee that a device can be installed in all vehicles. Designers need to be aware that as the number and coverage of airbags inside the passenger compartment increases, the difficulty in demonstrating that an internal roll-over protection device does not affect the operation of the airbags increases accordingly also. There will be an increasing number of vehicles that will not be suitable for having a roll-over protection device fitted internally.

Currently there are no roll-over provisions in the ADRs. Should this situation change, Codes LK8, LK9 and LK10 will need to be revised accordingly.

Table LK9 *Applicability Table for Codes LK8, LK9 and LK10* provides an illustrative summary in matrix form of the majority of installations that may require certification in Section LK. Table LK9 is not exhaustive and other installations may apply.

TERMS

The following terms apply in the context of Codes LK8, LK9 and LK10.

Internally Mounted Structure means a structural device that is located inside of the original body of the vehicle so that when it is attached to the vehicle it does not cause an increase in the legal width of the vehicle.

Externally Mounted Structure means a structural device that is located outside of the original body of the vehicle so that when it is attached to the vehicle it results in an increase in the legal width of the vehicle.

Roll-bar means a single hoop structure intended to protect the occupants of the vehicle in the case of a roll-over. (These devices are usually fitted to convertibles or cabriolets that are registered for unrestricted use. In certain circumstances a roll-bar is mandatory such as in the case where the roof and the upper portion of the *B* pillar are removed, thereby removing the upper anchorage points for the seatbelt. If after the roof modification is completed, no suitable structure is available to position the upper anchorage point for the seatbelt, a suitably designed roll-bar needs to be fitted to accommodate the upper anchorage point).

Roll-cage means a structure comprising more than one hoop designed to primarily protect the driver of the vehicle to which it is fitted in the case of a roll-over. In certain circumstances a navigator who sits in the front passenger seat may also need to be protected by the device.

(These structures are usually fitted to competition vehicles -- the rear seats of these vehicles are usually removed and no occupant protection is required for rear passengers).

Roll-over protection system or structure (ROPS) means a structure designed to protect the occupants of a vehicle to which the structure is fitted, in the case of a roll-over. (These devices are typically required by the mining industry, and are fitted to vehicles that are registered for unrestricted use. Consequently occupant protection needs to be considered for all passengers despite their seating position).

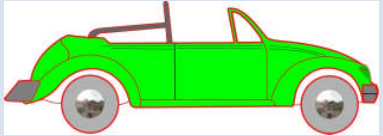

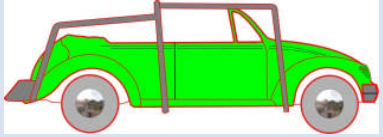











Figure LK20 Typical example of an internal ROPS fitted to a station wagon providing protection for both front and rear passengers.

Performance requirements in the context of LK9 and LK10 means the level of roll-over protection that is expected from the device in question over and above that already offered by the unmodified vehicle.









Requires Jurisdictional Approval includes approval obtained directly from an officer of a Registration Authority or certification from a signatory or other person authorised by a jurisdiction to certify modifications and/or installations in accordance with Codes LK8, LK9 and LK10.

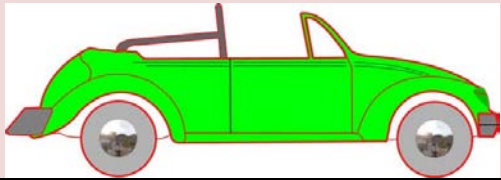

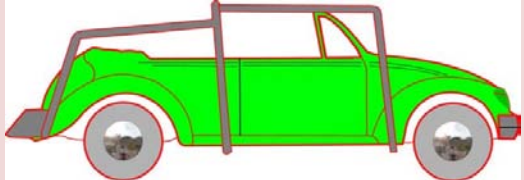
Table LK9 Applicability Table for Codes LK8, LK9 and LK10.



Production	Structure	Needs Performance Requirements Design	Needs Certification	Requires Jurisdictional Approval*	Comments	Typical Examples (for illustrative purposes only)
One Off Construction	Roll-bar Internal to the Vehicle	No	Yes - to LK8	Yes		 
	Roll-bar External to the Vehicle	Not Covered by VSB 14	Not Covered by VSB 14	By Application to Jurisdiction Only	May be considered on a case by case basis by the relevant jurisdiction.	 
	Roll-bar mounted outside of the cabin at the rear of a truck or utility	No	No	No	Provided the roll-bar does not result in an increase in the vehicle width.	   

Production	Structure	Needs Performance Requirements Design	Needs Certification	Requires Jurisdictional Approval*	Comments	Typical Examples (for illustrative purposes only)
One Off Construction	Roll-cage Internal to the Vehicle	No	Yes - to LK8	Yes	Limitations placed on the designs covered by LK8 – (Does not allow for structural elements to the A-Pillar).	 
	Roll-cage external to the Vehicle	Not Covered by VSB 14	Not Covered by VSB 14	By Application to Jurisdiction Only	May be considered on a case by case basis by the relevant jurisdiction.	
	ROPS (Internal to the Vehicle)	Not covered – Aftermarket Requirements apply	Not covered – Aftermarket Requirements apply	Not covered – Aftermarket Requirements apply	All ROPS need to be certified to LK9 and LK10.	

Production	Structure	Needs Performance Requirements Design	Needs Certification	Requires Jurisdictional Approval*	Comments	Typical Examples (for illustrative purposes only)
	ROPS (external to the Vehicle)	Not Covered by VSB 14	Not Covered by VSB 14	By Application to Jurisdiction Only	May be considered on a case by case basis by the relevant jurisdiction.	

Production	Structure	Needs Performance Requirements Design	Needs Certification to Section LK	Requires Jurisdictional Approval*	Comments	Typical Examples (for illustrative purposes only)
Aftermarket/ Commercial	Roll-bar Internal to the Vehicle	Yes - to LK9 and LK10	Yes - to LK9 and LK10	Yes		 
	Roll-bar External to the Vehicle	Not Covered by VSB 14	Not Covered by VSB 14	By Application to Jurisdiction Only	May be considered on a case by case basis by the relevant jurisdiction.	 
	Roll-bar mounted outside of the cabin at the rear of a truck or utility	No	No	No	Provided the roll-bar does not result in an increase in the vehicle width.	   

Production	Structure	Needs Performance Requirements Design	Needs Certification to Section LK	Requires Jurisdictional Approval*	Comments	Typical Examples (for illustrative purposes only)
Aftermarket/ Commercial	Roll-cage Internal to the Vehicle	Yes - to LK9 and LK10	Yes - to LK9 and LK10	Yes		
	Roll-cage external to the Vehicle	Not Covered by VSB 14	Not Covered by VSB 14	By Application to Jurisdiction Only	May be considered on a case by case basis by the relevant jurisdiction.	
	ROPS (Internal to the Vehicle)	Yes - to LK9 and LK10	Yes - to LK9 and LK10s	Yes		

Production	Structure	Needs Performance Requirements Design	Needs Certification to Section LK	Requires Jurisdictional Approval*	Comments	Typical Examples (for illustrative purposes only)
	ROPS (external to the Vehicle)	Not covered by VSB14	Not covered by VSB 14	By Application to Jurisdiction Only	May be considered on a case by case basis by the relevant jurisdiction.	 

* **Requires Jurisdictional Approval** includes approval obtained directly from an officer of a Registration Authority or certification from a signatory or other person authorised by a jurisdiction to certify modifications and/or installations in accordance with Codes LK8, LK9 and LK10.