

ONE WAY TRAFFIC DEPARTURE DETAILS are to be used only when there is no possibility of opposing traffic impacting them. They are not to be used within clear zone of opposing traffic.

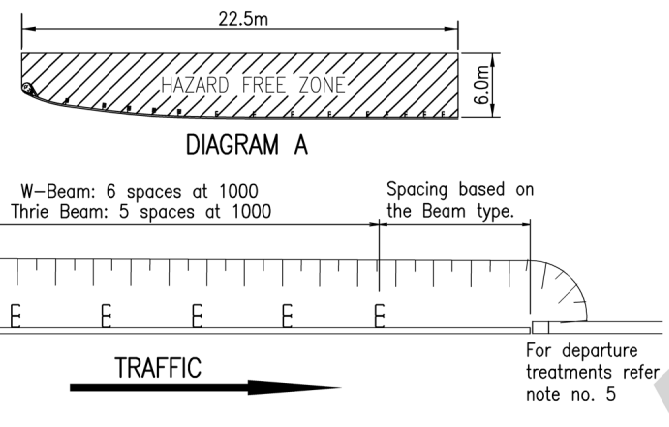

†1200 for Modified Thrie Beam  
 \* Denotes typical dimension for all cases. Where barriers are constructed on a grade this dimension shall be measured along reference line as shown.

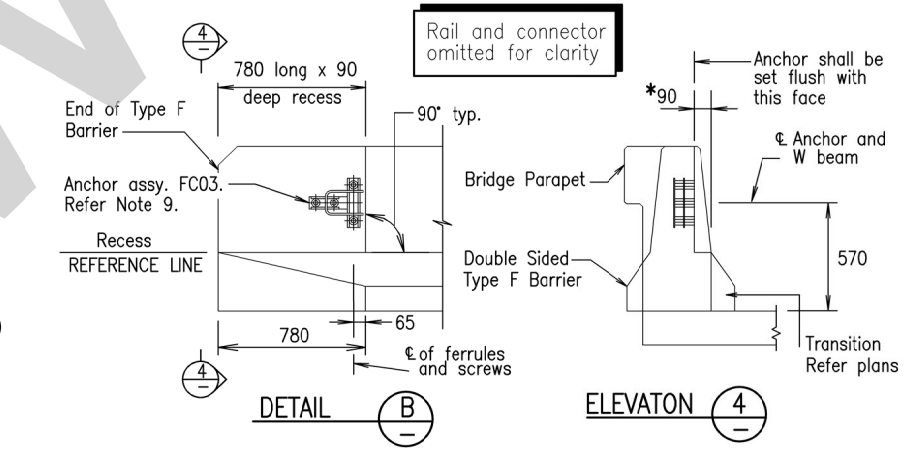
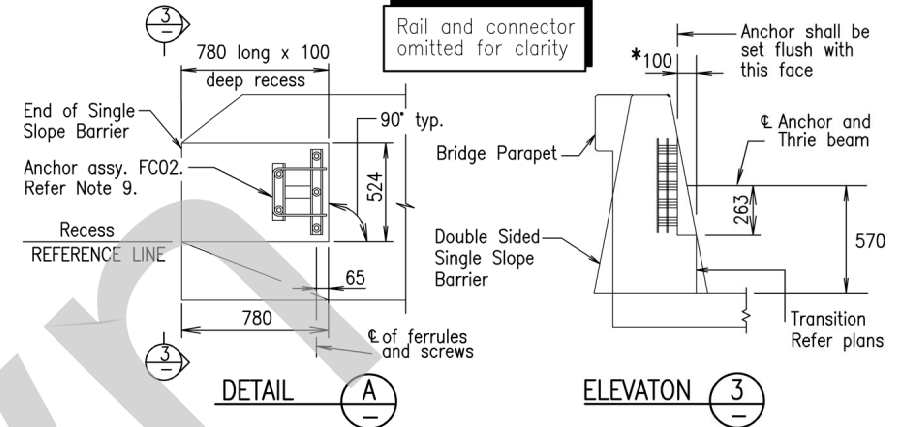
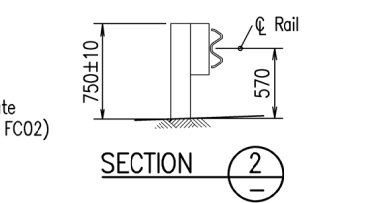
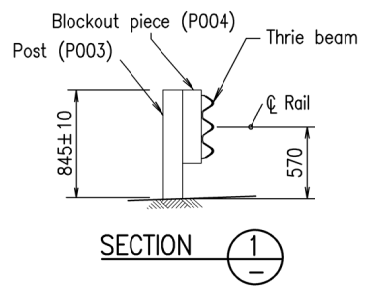
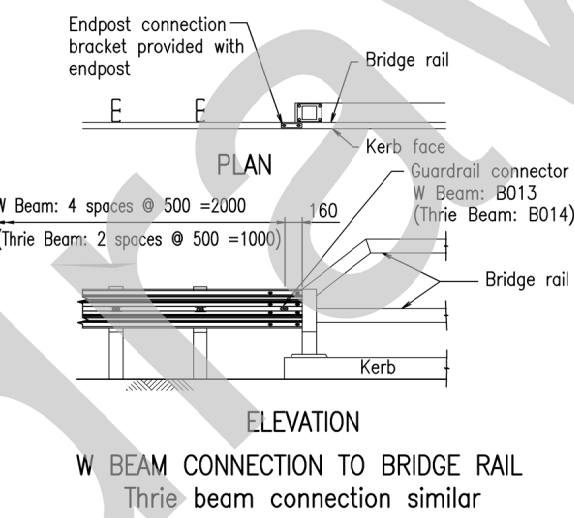

- NOTES:**
- RAIL LAP, post and blockout orientation in relation to traffic direction as shown is essential.
  - FASTENERS for blockout to post and rail to rail connections not shown on this drawing.
  - STIFFENER PLATES shall be used at posts without rail lap except in the MELT.
  - BLOCKOUT PIECE P006/P007 not to be used in thrie beam transition.
  - DEPARTURE TREATMENTS:
    - Two way traffic and within opposing traffic clear zone:- Same as for approach treatment.
    - Outside of opposing traffic clear zone:- Refer "One Way Traffic Departure Detail" on this drawing.
  - MELT and one way traffic departure end treatment setout as shown on Std Dwg 1474.
  - THE MINIMUM installed length of guardrail is:
    - 20 metres including transition, plus the length of a Terminal Type 1 or proprietary system.
    - 20 metres for one way traffic departure including a Terminal 2
  - W AND THRIE BEAM CONNECTION TO Parapet/Barrier refer to Bridge/Barrier drawings for details.
  - ANCHOR ASSEMBLIES (including bolts) are detailed on Std. Dwg. No. 1467.
  - NOTCHED BLOCKOUTS P006 and P007 are used for modified thrie beam guardrail as detailed on Std. Dwg. No. 1483.
  - APPROACH MELT details as shown on standard drawing 1474.
  - DEPARTURE MELT details as shown on standard drawing 1474.
  - ALL DIMENSIONS are in millimetres unless otherwise shown.

- ASSOCIATED DOCUMENTS:**  
 Main Roads Standard Drawings Roads Manual  
 Main Roads Specifications and Technical Standards Manual
- REFERENCED DOCUMENTS:**  
 Standard Drawings:  
 1467 Concrete Barrier/Bridge Parapet-Cast-in Anchor Assembly Connection.  
 1474 Steel Beam Guardrail - Installation and Setout  
 1483 Steel Beam Guardrail - Thrie Beam Layouts  
 Standard Specifications:  
 MRTS14A Road Furniture (Steel Work)  
 Australian Standards:  
 AS/NZS 3845 Road Safety Barrier Systems

This Standard Drawing is withdrawn. Public domain steel barrier systems are not to be used on new projects or installations within the TMR network. This drawing can be used for the purposes of maintaining existing installations when repairs and replacements can be reasonably and readily undertaken or if justified and certified by a RPEQ as an exception for new installation.

STEEL BEAM GUARDRAIL		Queensland Government	
Department of Transport and Main Roads		Standard Drawing No	
INSTALLATION ON BRIDGE AND BARRIER APPROACHES		1475	
A3		Date 1/11	
Not to Scale			
A	B	C	D