

# MAIN ROADS TECHNICAL STANDARD

## MRTS77

### Bridge Deck

**June 11**

 **Queensland** Government

## **TRADEMARKS ACKNOWLEDGEMENT**

Terms mentioned in this document that are known or understood to be trademarks, whether registered or not, have been identified. Where trademarks have been confirmed as registered in Australia, this has been indicated by the addition of the ® symbol, otherwise the ™ symbol is used. While all care has been taken to identify trademarks, users should rely on their own inquiries to determine trademark ownership. Use of a term in this document as a trademark should not be regarded as affecting the validity of any trademark.

## **IMPORTANT INFORMATION**

The requirements of this document represent Technical Policy of the department and contain Technical Standards. Compliance with the department's Technical Standards is mandatory for all applications for the design, construction, maintenance and operation of road transport infrastructure in Queensland by or on behalf of the State of Queensland.

This document will be reviewed from time to time as the need arises and in response to improvement suggestions by users. Please send your comments and suggestions to the feedback email given below.

## **FEEDBACK**

Your feedback is welcomed. Please send to [mr.techdocs@tmr.qld.gov.au](mailto:mr.techdocs@tmr.qld.gov.au).

## **DISCLAIMER**

This publication has been created for use in the design, construction, maintenance and operation of road transport infrastructure in Queensland by or on behalf of the State of Queensland.

Where the publication is used in other than the department's infrastructure projects, the State of Queensland and the department gives no warranties as to the completeness, accuracy or adequacy of the publication or any parts of it and accepts no responsibility or liability upon any basis whatever for anything contained in or omitted from the publication or for the consequences of the use or misuse of the publication or any parts of it.

If the publication or any part of it forms part of a written contract between the State of Queensland and a contractor, this disclaimer applies subject to the express terms of that contract.

## **COPYRIGHT**

Copyright protects this publication. Except for the purposes permitted by and subject to the conditions prescribed under the Copyright Act, reproduction by any means (including electronic, mechanical, photocopying, microcopying or otherwise) is prohibited without the prior written permission of the department. Enquiries regarding such permission should be directed to the Contracts and Technical Capability Branch, Queensland Department of Transport and Main Roads.

© State of Queensland (Department of Transport and Main Roads) 2011



<http://creativecommons.org/licences/by-nc-nd/2.5/au>

## Table of Contents

1	INTRODUCTION.....	1
2	DEFINITION OF TERMS .....	1
3	REFERENCED DOCUMENTS .....	1
3.1	Standard Drawings.....	2
4	QUALITY SYSTEM REQUIREMENTS.....	2
4.1	Hold Points, Witness Points and Milestones.....	2
4.2	Construction Procedures.....	3
5	MATERIALS.....	3
5.1	Epoxy Putty / Mortar.....	3
5.2	Joint Sealants.....	3
5.2.1	Bitumen Based.....	3
5.2.2	Gun Grade Polyurethane Joint Sealant.....	3
5.2.3	Silicone Joint Sealant .....	4
5.3	Compressible Filler .....	4
5.4	Closed Cell Expanded Polyethylene Sheeting.....	4
5.5	Cement Mortar .....	4
5.6	Dry Stabilised Sand.....	4
5.7	Tape .....	4
5.8	Closed Cell Foam Rod.....	4
5.9	Cold Galvanising Paint.....	4
6	CONCRETE .....	5
7	STEEL REINFORCING.....	5
8	PREPARATION OF PRESTRESSED CONCRETE DECK UNITS .....	5
9	PREPARATION OF PRESTRESSED CONCRETE T GIRDERS .....	5
10	CONSTRUCTION OF CROSS GIRDERS .....	5
10.1	Temporary Bracing.....	5
10.2	Preparation for Cross Girders to Prestressed Concrete Girders .....	5
10.3	Preparation for Cross Girders to Steel Girders .....	5
10.4	Formwork .....	6
11	CONSTRUCTION OF REINFORCED CONCRETE DECK, KERBS, PARAPETS AND RELIEVING SLABS .....	6
11.1	General.....	6
11.2	Surface Preparation .....	6
11.3	Formwork .....	6
11.4	Thickness and Level of Deck .....	6
11.5	Pre-camber of Deck Formwork.....	6
11.6	Embedded Items .....	6
11.7	Cast-in Aluminium Expansion Joint .....	7
11.8	Placement Procedures.....	7
11.9	Concrete Joints .....	7
11.10	Treatment at Abutting Ends of Prestressed Concrete Deck Units.....	7
11.11	Joint Sealant .....	7
11.12	Surface Finishes .....	7
11.13	Tolerances.....	8
11.14	Formwork Supports.....	8
12	INSTALLATION OF GIRDER RESTRAINTS .....	8
13	EMBEDDED ITEMS .....	8
13.1	Anchors for Bridge Railing and Lamp Standards.....	8
13.2	Sockets for Extruded Aluminium Expansion Joint .....	9

13.3	Sockets for Fibre Reinforced Concrete Expansion Joints.....	10
13.4	Date Plate.....	10
13.5	Permanent Survey Mark.....	10
13.6	Scuppers .....	10
14	ELECTRICAL COMPONENTS .....	11
14.1	Conduits .....	11
14.2	Lamp Standard Brackets.....	11
15	STAINLESS STEEL COVER PLATES .....	11
15.1	General.....	11
15.2	Material.....	11
15.3	Fabrication.....	11
15.4	Installation .....	12
16	NAVIGATION MARKERS.....	12
17	STABILISED SAND IN FOOTWAY .....	12
18	PRECAST CONCRETE FOOTWAY SLABS.....	12
19	DECK WEARING SURFACE.....	13
19.1	Asphalt Surfacing .....	13
19.2	Deck Expansion Joint.....	13
20	LOAD LIMITATION ON NEWLY CAST DECKS.....	13
20.1	Construction Loads (Light) .....	13
20.2	Construction Loads (Heavy).....	13
20.3	Legal Traffic Loads.....	14
21	ANTI-GRAFFITI PROTECTION .....	14
22	SUPPLEMENTARY REQUIREMENTS .....	14

# Bridge Deck

## 1 INTRODUCTION

This Standard applies to the construction of a reinforced concrete bridge deck constructed on prestressed concrete deck units, prestressed concrete girders or steel girders.

This Standard shall be read in conjunction with MRTS01 *Introduction to Technical Standards*, MRTS50 *Specific Quality System Requirements* and other Technical Standards as appropriate.

This Standard forms part of the Main Roads Specifications and Technical Standards Manual.

The requirements for construction of bridge decks include the use of suppliers and products for the items listed in Table 1 that are registered by Transport and Main Roads.

**Table 1 – Items Requiring Use of Registered Suppliers and Products**

<b>Clauses</b>	<b>Category of Work</b>
5.1	Epoxy Putty/Mortar
5.2.1	Bitumen based joint sealant.
5.2.2	Polyurethane elastomer based joint sealant.
5.2.3	Silicone joint sealant.
5.4	Compressible filler.
5.5	Closed cell expanded polyethylene sheeting.
5.8	Tape.
5.9	Closed Cell Foam Rod
5.10	Cold galvanising paint
11.11	Joint sealant.
13.4	Date Plate
13.5	Permanent Survey Mark

For information regarding registered suppliers and products for the above items refer to –

Director (Bridge Design)  
 Structures Division  
 Department of Transport and Main Roads  
 GPO Box 1412  
 Brisbane Qld 4001

## 2 DEFINITION OF TERMS

The terms used in this Standard shall be as defined in Clause 2 of MRTS01 *Introduction to Technical Standards*.

## 3 REFERENCED DOCUMENTS

Table 3 lists documents referenced in this Technical Standard.

**Table 3 – Referenced Documents**

<b>Reference</b>	<b>Title</b>
AS 1214	Hot-dip galvanized coatings on threaded fasteners (ISO metric coarse thread series)
AS/NZS 2053.1	Conduits and fittings for electrical installations General

<i>Reference</i>	<i>Title</i>
	requirements
AS/NZS 2053.2	Conduits and fittings for electrical installations Rigid plain conduits and fittings of insulating material
AS/NZS 2053.5	Conduits and fittings for electrical installations Corrugated conduits and fittings of insulating material
AS 2439	Perforated plastics drainage and effluent pipe and fittings Perforated drainage pipe and associated fittings
AS/NZS 3000	Electrical Installations (known as The Australian/New Zealand wiring rules)
AS/NZS 4680	Hot-dip galvanized (zinc) coatings on fabricated ferrous articles
TS-009	Austel Technical Standard Installation requirements for customer cabling – wiring rules.

### **3.1 Standard Drawings**

Table 3.1 lists Standard Drawings referenced in this Technical Standard.

**Table 3.1 – Standard Drawings**

<i>Reference</i>	<i>Title</i>
1063	Standard Date Plate – General Arrangement
1505 or 1506	Retaining Structures – Bridge Approach Relieving Slab

## **4 QUALITY SYSTEM REQUIREMENTS**

### **4.1 Hold Points, Witness Points and Milestones**

General requirements for Hold Points, Witness Points and Milestones are specified in Clause 5.2 of MRTS01 *Introduction to Technical Standards*.

The Hold Points, Witness Points and Milestones applicable to this Standard are summarised in Table 4.1

**Table 4.1 – Hold Points, Witness Points and Milestones**

<i>Clause</i>	<i>Hold Point</i>	<i>Witness Point</i>	<i>Milestone</i>
10.1			Submission of details for bracing cross girders (14 days).
10.2	1. Casting cross girders.		
11.1	2. Casting deck.		
11.4	3. Lifting of deck surface levels.		
11.8	4. Deck placement procedure.		Submission of deck placement procedure (21 days).
13.2		Concreting around anchors for extruded aluminium expansion joints.	

<i>Clause</i>	<i>Hold Point</i>	<i>Witness Point</i>	<i>Milestone</i>
13.3		Concreting around anchors for fibre reinforced concrete expansion joints.	
15.3	5. Welding procedure for stainless steel cover plates.		
18	6. Erection procedure for footway slabs.		Submission of footway slab erection procedure (14 days).
20.1 & 20.2	7. Loading of deck. (Construction)		
20.3	8. Legal Traffic Loads		

#### **4.2 Construction Procedures**

The Contractor shall prepare documented procedures for all construction processes in accordance with the quality system requirements of the Contract.

Procedures for those activities listed in Table 4.2 and Clause 1 of Annexure MRTS77.1 shall be submitted to the Administrator in accordance with the quality system requirements of the Contract.

**Table 4.2 – Construction Procedures**

<i>Clause</i>	<i>Conformance Requirement</i>
11.8	Placement of concrete in deck.

## **5 MATERIALS**

### **5.1 Epoxy Putty / Mortar**

Epoxy putty or mortar shall consist of a proprietary two-part epoxy product capable of gap filling between steel plate and a wood trowelled concrete surface.

A certificate from the manufacturer shall be provided to verify the suitability of the product for the intended purpose and shall be applied in accordance with the manufacturer’s recommendations.

The Epoxy Putty/Mortar shall be one of the registered products (refer CLAUSE 1).

### **5.2 Joint Sealants**

#### **5.2.1 Bitumen Based**

Bitumen based joint sealants shall exhibit superior adhesion to concrete and steel surfaces and shall have consistent extension properties at temperatures between 15°C and 75°C. Bitumen based joint sealants shall melt at elevated temperatures (greater than 170°C) and form a soft rubber at ambient temperatures.

Bitumen based joint sealants shall be one of the registered products (refer Clause 1).

Bitumen Based Joint Sealants shall be one of the registered products (refer CLAUSE 1).

#### **5.2.2 Gun Grade Polyurethane Joint Sealant**

Polyurethane elastomer based joint sealant shall be a two component product suitable for application in vertical joints using a dispensing gun.

Polyurethane elastomer based joint sealant shall be one of the registered products (refer Clause 1).

Registered products are listed in Clause 4.2 of Annexure MRTS77.1.

### **5.2.3 Silicone Joint Sealant**

Silicone joint sealant shall be a silicone sealant, suitable for application using a dispensing gun, for use on concrete surfaces.

Silicone joint sealant shall be one of the registered products (refer Clause 1).

Registered products are listed in Clause 4.3 of Annexure MRTS77.1. Fibre Cement Sheet

Fibre cement sheeting shall be a compressed fibre cement product capable of supporting deck concrete placement loads. Fibre cement sheeting shall be cut into strips of width and thickness shown in the Drawing. Cutting and handling shall be in accordance with the manufacturer's recommendations.

### **5.3 Compressible Filler**

Compressible filler shall consist of a bitumen impregnated fibrous material such as caneite. Compressible filler shall be installed in accordance with the manufacturer's recommendations.

Compressible filler shall be one of the registered products (refer Clause 1).

Registered products are listed in Clause 2 of Annexure MRTS77.1.

### **5.4 Closed Cell Expanded Polyethylene Sheeting**

Closed cell expanded polyethylene sheetings shall be an approved proprietary product. The thickness of closed cell polyethylene filler shall be as shown in the Drawing.

Closed cell expanded polyethylene sheetings shall be one of the registered products (refer Clause 1).

Registered products are listed in Clause 3 of Annexure MRTS77.1.

### **5.5 Cement Mortar**

Cement mortar shall consist of 1 part of Type GP cement and 3 parts of clean sharp sand with just sufficient water added to form a creamy consistency.

### **5.6 Dry Stabilised Sand**

Dry stabilised sand shall comply with the requirements of Clause 20 of MRTS04 *General Earthworks*.

### **5.7 Tape**

Tape for use in sealing joints between precast elements shall comprise a self-adhesive bituminous membrane incorporating a reinforcing heavy duty plastic film or woven fibre.

The tape shall be applied in accordance with the manufacturer's recommendations.

The tape shall be one of the registered products (refer Clause 1).

Registered products are listed in Clause 5 of Annexure MRTS77.1

### **5.8 Closed Cell Foam Rod**

Closed Cell Polyethylene Foam Backing Rod for use in sealing joints between precast elements.

The backing rod shall be applied in accordance with the manufacturer's recommendations.

The backing rod shall be one of the registered products (refer Clause 1).

Registered suppliers are listed in Clause 11 of Annexure MRTS77.1

### **5.9 Cold Galvanising Paint**

Cold Galvanising Paint shall be based on inorganic zinc rich material as per MRTS78 and applied in accordance with the manufacturer's recommendations.

The paint shall be sourced from a registered supplier. Registered suppliers are listed in Clause 9 of Annexure MRTS77.1

## 6 CONCRETE

The supply, manufacture, placement, surface finish and curing of concrete shall be in accordance with the requirements of MRTS70 *Concrete*.

## 7 STEEL REINFORCING

The supply, fabrication and placement of steel reinforcing shall be in accordance with the requirements of MRTS71 *Reinforcing Steel*.

## 8 PREPARATION OF PRESTRESSED CONCRETE DECK UNITS

When the Drawing shows cast in situ concrete is to be placed on precast units, the top surface of the unit shall be cleaned of any oil, clay, grout or other foreign material prior to placing concrete. No additional surface roughening is required unless specifically stated otherwise in the Drawing.

Along adjacent edges of precast units, a tape seal shall be installed on the top surface of the units. The tape seal shall overlap the edges of units by at least 40 mm.

Prior to application of the tape, the top surface of the units shall be swept clean.

The tape shall be applied in accordance with the manufacturer's recommendations.

## 9 PREPARATION OF PRESTRESSED CONCRETE T GIRDERS

Construction plant or equipment or vehicles of any type shall not be placed on the girders prior to casting the concrete deck.

Along the abutting edges of adjacent T girders, a tape seal shall be installed on the top surface of the flanges. The tape seal shall overlap the edge of the flange by at least 40 mm.

Prior to application of the tape, the surface of the flanges shall be swept clean.

The tape shall be applied in accordance with the manufacturer's recommendations.

## 10 CONSTRUCTION OF CROSS GIRDERS

### 10.1 Temporary Bracing

Temporary bracing, consisting of struts and ties to effectively prevent spreading or sideways movement of the girders during construction of the cross girders, shall be erected near each cross girder. Details of such bracing shall be submitted to the Administrator at least 14 days before construction of the cross girders. **Milestone.**

The bracing shall remain in place for at least 2 days after the adjacent cross girder has been cast.

### 10.2 Preparation for Cross Girders to Prestressed Concrete Girders

For a deck supported by prestressed concrete girders, cross girders shall not be cast until the interface area on the girder has been roughened by scabbling or sand blasting as shown in the Drawing. **Hold Point 1** Unless otherwise specified, this roughening shall have been carried out as part of the girder manufacture in accordance with MRTS73 *Manufacture of Prestressed Concrete Members and Stressing Bars*.

### 10.3 Preparation for Cross Girders to Steel Girders

Where the deck is supported by steel girders, longitudinal steel reinforcing in reinforced concrete cross girders shall be either welded to the existing cross girder reinforcement, as detailed in the Drawing(s) or located by nuts at the outer girders. The alignment of the girders shall be adjusted using nuts on the threaded ends of these bars. The nuts and washers shall be tack welded to prevent subsequent rotation.

Any welding shall be treated with two coats of an approved cold galvanising paint (inorganic zinc rich paint) in accordance with the manufacturer's recommendations.

The paint shall be sourced from a registered supplier. Registered suppliers are listed in Clause 9 of Annexure MRTS77.1

#### 10.4 Formwork

The formwork for the cross girders shall be supported from the girders.

### 11 CONSTRUCTION OF REINFORCED CONCRETE DECK, KERBS, PARAPETS AND RELIEVING SLABS

#### 11.1 General

The reinforced concrete deck and kerbs shall be cast in the sequence shown in the Drawing. The deck shall not be cast until 7 days after cross girders have been cast, where applicable. **Hold Point 2**

Parapets shall be cast separately from reinforced concrete decks and/or kerbs. Parapets shall be cast in one lift vertically.

Components which are consumed from precast concrete shall be manufactured in accordance with MRTS72.

Unless detailed otherwise in the Drawing, relieving slabs shall be constructed in accordance with the details shown on Standard Drawings number 1505 and 1506.

#### 11.2 Surface Preparation

Steel reinforcing and other steelwork protruding from units or girders shall be cleaned, in accordance with Clause 8 of MRTS71 *Reinforcing Steel* before any steel reinforcing bars or concrete is placed.

The top surface of units or girders shall be swept clean of loose material and rubbish but shall not be otherwise disturbed.

#### 11.3 Formwork

Formwork for the deck slab and kerbs shall be supported from the girders. In no case shall the formwork be tommed from the ground.

Where shown in the Drawing, fibre cement sheet strips shall be installed over any gaps and/or joints between prestressed deck units to act as sacrificial formwork. Fibre cement sheet strips shall be set in cement mortar.

#### 11.4 Thickness and Level of Deck

The deck thickness shall not be less than that shown in the Drawing nor shall it be increased without the Administrator's approval. In cases of excessive hog, lifting of the deck surface levels in order to preserve the minimum thickness of the deck over the units or girders may be necessary. Lifting of the deck surface levels shall not be carried out unless prior approval has been given by the Administrator. **Hold Point 3**

#### 11.5 Pre-camber of Deck Formwork

In order that the finished surface of the deck and kerbs be true to grade longitudinally, the deck formwork for each span shall be pre-cambered vertically in the longitudinal direction, as shown in the Drawing, so as to cancel the subsequent downward deflection due to the weight of the deck and kerbs.

Should the measured deflections of the first spans cast vary appreciably from those shown in the Drawing, the cambers for the remaining spans shall be adjusted accordingly.

#### 11.6 Embedded Items

Embedded items shall be supplied and installed where shown in the Drawing and in accordance with Clauses 13, 14, 15 and 16, as applicable.

Embedded items shall be set true to the locations shown in the Drawing and shall be held firmly in position so that they are not displaced during placement of concrete.

### **11.7 Cast-in Aluminium Expansion Joint**

Where the reinforced concrete deck is to be the final surface and an asphalt deck wearing surface is not required, a cast-in extruded aluminium expansion joint shall be installed in accordance with the requirements of MRTS82 *Bridge Deck Expansion Joints*.

### **11.8 Placement Procedures**

The Contractor shall submit to the Administrator, at least 21 days before the deck is due to be cast, full details of the equipment and methods proposed to be used to place, compact and finish the deck concrete. Milestone Such equipment and methods shall be verified by the Administrator before use. **Hold Point 4**

Unless otherwise specified, concrete in the deck slab, in each span, shall be placed in one operation. The concrete in the kerbs shall be placed at the same time as the concrete in the deck slab except where a construction joint between the deck slab and kerb is shown in the Drawing.

### **11.9 Concrete Joints**

Expansion joints and construction joints shall be installed at the locations and in accordance with the details shown in the Drawing.

Expansion joints shall be formed using compressible filler of the appropriate thickness in accordance with Clause 5.4 in the locations and to the details shown in the Drawing.

### **11.10 Treatment at Abutting Ends of Prestressed Concrete Deck Units**

For a deck supported by prestressed concrete deck units and where shown in the Drawing, construction joints shall be provided on both sides of and adjacent to the abutting ends of deck units. Prior to casting the infill section of deck slab after the nominated delay period, a sheet of closed cell expanded polyethylene sheet shall be installed on the top of the deck units as shown in the Drawing.

### **11.11 Joint Sealant**

Joints shall be sealed with a registered joint sealant (refer Clause 1) as shown in the Drawing.

The surfaces to which joint sealant is to be applied shall be prepared in accordance with the manufacturer's recommendations.

Hot applied bitumen based joint sealant shall be mixed, heated and applied strictly in accordance with the manufacturer's recommendations.

Where bitumen based joint sealant is required to be applied to a recess in a vertical surface, leak-proof forms shall be provided to retain the molten bitumen product until it cools. Alternatively, a gun grade, two pack polyurethane elastomer joint sealant may be applied using an appropriate dispensing gun. Two pack polyurethane shall be mixed thoroughly in accordance with the manufacturer's recommendations.

Silicone joint sealant shall be applied direct from the cartridge with an appropriate dispensing gun. Vertical recesses shall be filled from the bottom up.

Closed-cell expanded polyethylene filler rods shall be installed in joints where appropriate such that the cross section of the joint sealant remains approximately square or as otherwise recommended by the sealant manufacturer.

### **11.12 Surface Finishes**

The deck shall be screeded in the longitudinal direction. The screed shall travel on levelled runners and, preferably, shall extend in one piece from kerb to kerb.

The deck surface finish shall generally be in accordance with MRTS70 *Concrete* for those cases where the traffic is in direct contact with the concrete surface.

The surface shall be brushed in a direction at right angles to the direction of traffic using a broom not less than 400 mm wide to achieve an average texture depth of 0.8 mm. The texture depth produced by brushing shall be measured by the method described in Test Method Q705. The average texture depth for each set of tests shall not be less than 0.8 mm and not more than one test in each set shall show a texture depth of less than 0.6 mm. Tests in a set shall be carried out at one metre intervals along a line one metre inside any lane

edge. The number of tests in a set shall be ten. Testing shall be carried out as soon as practicable after curing of the concrete and before construction traffic is permitted to use the surface. Where compliance with the requirements of this section is not achieved, the Contractor shall make good the deficiencies in the texture depth by transverse mechanical grooving of the concrete surface by a means approved by the Administrator.

In cases where the concrete deck is overlain with a bituminous deck wearing surface, a suitable bond surface shall be achieved by means of brooming after initial set has taken place or, alternatively, by rolling with a small diameter expanded metal roller.

Kerbs shall be finished true to line with a smooth even surface and with chamfers neatly formed.

Finishes shall be obtained without plastering. Kerbs may require to be rubbed with a carborundum stone to produce the required finish.

### **11.13 Tolerances**

Concrete shapes and profiles shall be constructed to the tolerances specified in MRTS70 *Concrete* except as stated below.

In cases where the concrete deck is overlain with a bituminous deck wearing surface, the tolerance on the top surface of the deck may be relaxed to  $\pm 20$  mm provided that the deck thickness limitations of Clause 11.4 are maintained.

Notwithstanding all other provisions of the Drawing and/or Standards, the line of exposed edges of kerbs and medians shall form straight lines or smooth curves, as appropriate, and exposed faces shall form true planes between edges. The visual impact of the completed structures is considered important.

### **11.14 Formwork Supports**

After completion of casting kerbs and/or parapets, any inserts provided in prestressed concrete units or the cast in situ deck for the support of formwork shall be extracted, where possible, and the remaining voids backfilled with cement mortar.

## **12 INSTALLATION OF GIRDER RESTRAINTS**

The requirements of this Clause shall apply where restraint angles are used to anchor girders to the substructure.

At least 7 days after casting the deck slab, the girder restraint angles shall be permanently seated. The restraint angles at one end only of a girder shall be removed at any time for final seating.

The girder restraint angles shall be completely bedded on epoxy putty.

At the fixed end of the girder, the girder restraint angles shall be installed in such a manner that the girder bears on the girder restraint angles. The thickness of the epoxy putty shall be such that the girder restraint fastener touches the top of the hole in the girder restraint angles.

At the expansion joint end of the girder, the girder restraint angle shall be installed in such a manner that the girder restraint fastener is located mid-way along the length of the slotted hole in the girder restraint angle. The thickness of the epoxy putty shall be such that the girder restraint fastener touches the top of the slot in the girder restraint angles.

The girder restraint angles shall be supported in the correct positions until the epoxy putty has hardened. After the epoxy putty has cured, all nuts shall be securely tightened.

If the bridge is located on a vertical grade, care shall be exercised to ensure that no shear deflection is induced in the bearings or that the girders and/or deck do not move downhill during the above operations.

## **13 EMBEDDED ITEMS**

### **13.1 Anchors for Bridge Railing and Lamp Standards**

Anchor studs and sockets for bridge railing, lamp standard brackets and guardrail terminals shall be fabricated as shown in the Drawing. Fabrication shall be carried out in accordance with the requirements of MRTS78 *Fabrication of Structural Steelwork*.

Anchor studs and sockets shall be hot-dipped galvanised in accordance with the requirements of AS 1214 or AS 4680, as appropriate.

Male threads shall be cleaned after galvanising with a die nut and nuts and washers assembled on to studs. Female threads shall be cleaned with a tap after galvanising and bolts or studs and washers assembled into sockets.

### 13.2 Sockets for Extruded Aluminium Expansion Joint

Sockets for extruded aluminium expansion joints shall be fabricated to the details shown in Figure 13.2-A.

Sockets shall be fabricated from Grade 316 stainless steel. The cylinder section of the sockets shall be fabricated from a single piece of stainless steel.

The sockets shall have threads lightly greased and shall be set up to line and level in a rigid template.

Deck concrete shall be placed and well compacted around sockets with care to avoid displacement of sockets. **Witness Point**

After stripping of the installation template, plastic plugs shall be inserted in the sockets.

The tolerance on location of sockets shall be as shown in Figure 13.2-B and as described in Table 13.2.

**Figure 13.2-A – Extruded Aluminium Expansion Joint Sockets**

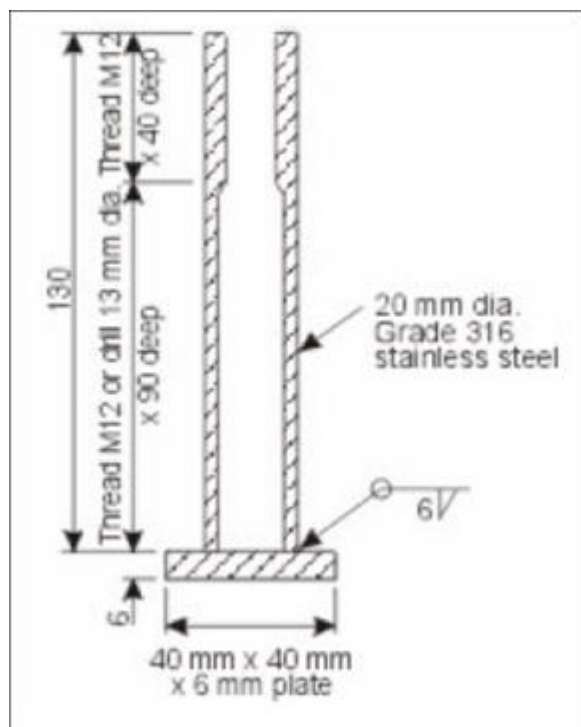

**Table 13.2 – Tolerances on Expansion Joint Socket Location**

Dimension		Tolerance (mm)
a)	Deviation from a straight line across the bridge	± 2
b)	Deviation from the correct centreline spacing between rows.	± 5
c)	Deviation from the correct lateral position in each row.	± 5
d)	Deviation from the correct level.	± 5

**Figure 13.2-B – Tolerances on Expansion Joint Socket Location**

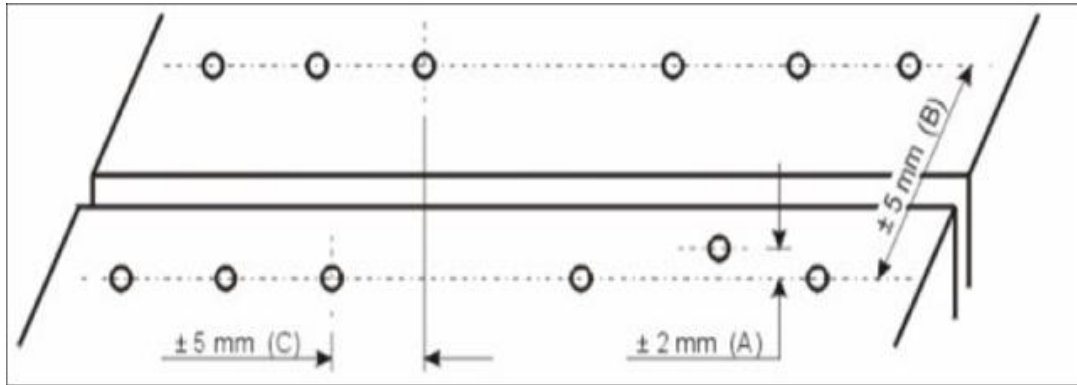

### 13.3 Sockets for Fibre Reinforced Concrete Expansion Joints

Sockets for fibre reinforced concrete expansion joints shall be proprietary cast-in threaded sockets of a diameter to suit the anchor rods. Sockets shall be either –

- a) Grade 316 stainless steel; or
- b) Grade 250 mild steel and hot dipped galvanised in accordance with AS 1214 or AS 4680, as appropriate.

as detailed in the Drawing.

Galvanised sockets shall be re-tapped after galvanising to clear the threads.

The sockets shall have threads lightly greased and shall be set up to line and level in a rigid template.

Deck concrete shall be placed and well compacted around sockets with care to avoid displacement of sockets. **Witness Point**

After stripping of the installation template, plastic plugs shall be inserted in the sockets.

The tolerance on the location of sockets shall be in accordance with the requirements of MRTS70 *Concrete*.

### 13.4 Date Plate

A date plate shall be cast into the bridge superstructure where shown in the Drawing.

Date plates shall be cast brass plates manufactured in accordance with Standard Drawing Number 1063.

Date plates shall be supplied by one of the registered suppliers (refer Clause 1).

Registered suppliers are listed in Clause 6 of Annexure MRTS77.1. Alternative suppliers may be submitted to the Administrator for approval.

### 13.5 Permanent Survey Mark

A permanent survey mark, if shown in the Drawing, shall be cast into the bridge superstructure where shown in the Drawing.

Permanent survey marks shall be standard brass plaques approved by the Association of Consulting Surveyors (Queensland).

Permanent survey mark shall be supplied by one of the registered suppliers (refer Clause 1).

Registered suppliers are listed in Clause 7 of Annexure MRTS77.1. Alternative suppliers may be submitted to the Administrator for approval.

### 13.6 Scuppers

Scuppers shall be fabricated from 150 mm diameter UPVC pipe as shown in the Drawing. UPVC pipe and fittings shall conform to the requirements of AS 2439.1.

Scuppers shall be installed in the locations and to the details shown in the Drawing.

## 14 ELECTRICAL COMPONENTS

### 14.1 Conduits

Conduit for electrical and/or telecommunications purposes shall be –

- a) cast into the kerbs and/or parapets; and/or
- b) installed in the void of bridge footways,

in the locations and in accordance with the details shown in the Drawing.

Conduit shall be one of the following, as appropriate and as shown in the Drawing –

- a) for electrical power purposes, conduit and fittings shall be rigid, non-metallic electrical conduit manufactured to comply with the requirements of AS 2053 and conforming to the heavy duty requirements of AS 2053, Part 2;
- b) where required, flexible conduit and fittings shall be manufactured to comply with the requirements of AS 2053, Parts 1 and 5; or
- c) for telecommunications cabling purposes, conduit and fittings shall comply with the requirements of Austel Technical Standard TS-009, Installation Requirements for Customer Cabling – Wiring Rules.

Conduits shall be installed in accordance with the requirements of MRTS91 *Conduits and Pits*. Conduit shall be installed true to line and shall be adequately secured to ensure that it does not float during concreting operations.

A draw rope shall be provided in each conduit. Draw rope shall be a general all-purpose 4 mm diameter synthetic polypropylene filament rope or equivalent. Draw ropes shall have a minimum of 1.5 metres of slack in each conduit and rope ends shall be firmly secured to prevent the ends being lost within the conduit.

### 14.2 Lamp Standard Brackets

Lamp standard brackets shall be fabricated to the details shown in the Drawing and in accordance with the requirements of MRTS78 *Fabrication of Structural Steelwork*. Lamp standard brackets shall be hot-dipped galvanised in accordance with the requirements of AS 4680.

Lamp standard brackets shall be installed on the bridge superstructure in the locations shown in the Drawing.

## 15 STAINLESS STEEL COVER PLATES

### 15.1 General

Stainless steel cover plates shall be supplied, fabricated and installed where shown in the Drawing at electrical junction boxes and over kerbs at expansion joints.

### 15.2 Material

Plate for cover plates shall be stainless steel grade 316.

Cast-in sockets or sockets installed after concreting shall be either –

- a) Grade 316 stainless steel; or
- b) Grade 250 mild steel hot-dipped galvanised in accordance with the requirements of AS 1214 or AS 4680, as appropriate.

as detailed in the Drawing.

Set screws and/or bolts shall be grade 304 stainless steel.

### 15.3 Fabrication

Stainless steel cover plates shall be fabricated to the details shown in the Drawing in accordance with the requirements of MRTS78 *Fabrication of Structural Steelwork*.

Before fabrication commences, all dimensions shall be checked on the Site.

A Welding Procedure Sheet shall be submitted to the Administrator for verification before fabrication commences. **Hold Point 5**

Exposed surfaces of cover plate shall be free from cuts, burrs, abrasions and other defects.

#### **15.4 Installation**

Sockets for installation of cover plates shall be cast into the bridge deck, kerb or parapet concrete in the locations shown in the Drawing. Alternatively proprietary sockets may be drilled into concrete after placement and installed in accordance with the manufacturer's recommendations. Concrete shall be at least 14 days old prior to installation of drilled sockets.

Prior to installing bolts and/or set screws into sockets, threads shall be coated with a suitable thread locking compound. Bolts and/or set screws shall be firmly tightened.

Electrical junction box cover plates shall be installed with a neoprene gasket.

Cover plates which do not bed satisfactorily on the concrete surface shall be rejected.

### **16 NAVIGATION MARKERS**

Navigation markers shall be fabricated to the details shown in the Drawing.

Steelwork shall be fabricated in accordance with the requirements of MRTS78 *Fabrication of Structural Steelwork*. Steelwork shall be hot-dipped galvanised in accordance with the requirements of AS 4680.

Aluminium components shall be fabricated in accordance with the requirements of MRTS79 *Fabrication of Aluminium Components*.

Specific colour coatings shall be applied to the surface of the aluminium marker in accordance with the details shown in the Drawing.

Navigation markers shall be installed in the locations shown in the Drawing. Anchor bolts or sockets shall be cast into the concrete or the concrete shall be drilled and the anchors installed in accordance with the manufacturer's recommendations.

Electrical conduit shall be installed from the nearest junction box to the navigation marker as shown in the Drawing. Conduit shall be installed in accordance with the requirements of MRTS91 *Conduits and Pits*.

The navigation marker luminaire shall be supplied and installed as shown in the Drawing. Installation shall comply with the requirements of AS 3000.

The luminaire shall be cabled to a point of supply of electricity in accordance with the requirements of MRTS95 *Switchboards and Cables*.

The installation shall be tested as required by MRTS95 *Switchboards and Cables* and/or AS 3000.

### **17 STABILISED SAND IN FOOTWAY**

Where shown in the Drawing, the void in any footways shall be backfilled with dry stabilised sand.

Dry stabilised sand shall be placed and compacted in accordance with the requirements of MRTS04 *General Earthworks*. Stabilised sand shall be compacted to 95% RDD.

Care shall be taken to surround any electrical or telecommunications conduit installed in the footway void with stabilised sand and to compact the stabilised sand without distortion or movement of the conduit.

### **18 PRECAST CONCRETE FOOTWAY SLABS**

If shown in the Drawing, precast reinforced concrete footway cover slabs shall be manufactured and installed on the bridge superstructure.

Precast reinforced concrete footway slabs shall be manufactured to the details shown in the Drawing in accordance with the requirements of MRTS72 *Manufacture of Precast Concrete Elements*.

Footway slabs shall be lifted using a suitable bridle or sling attached only to the lifting points cast into the slab.

The Contractor shall submit to the Administrator, at least 14 days before installation commences, its proposed procedure for handling and installation of footway slabs **Milestone**. Installation shall not commence until the procedure has been approved by the Administrator. **Hold Point 6**

Footway slabs damaged during manufacture, transport, handling and/or installation shall be rejected.

Following installation, construction plant and vehicles shall not proceed onto footway slabs nor shall equipment and materials be stacked on footway slabs.

## 19 DECK WEARING SURFACE

### 19.1 Asphalt Surfacing

Where shown in the Drawing an asphalt deck wearing surface shall be constructed on the concrete deck. The deck wearing surface shall be constructed in accordance with the requirements of MRTS84 *Deck Wearing Surface*.

The deck wearing surface shall not be constructed until –

- a) the deck concrete has reached its 28 day characteristic strength; and
- b) 21 days have elapsed since the deck concrete was placed.

### 19.2 Deck Expansion Joint

Where applicable, deck expansion joints shall be supplied and installed in accordance with the requirements specified in MRTS82 *Bridge Deck Expansion Joints*.

Expansion joints shall be either bolted-in extruded aluminium expansion joints or fibre reinforced concrete expansion joints as shown in the Drawing.

## 20 LOAD LIMITATION ON NEWLY CAST DECKS

### 20.1 Construction Loads (Light)

The Contractor shall move light construction equipment, and light vehicles (twin axle maximum) and shall superimpose small quantities of steel reinforcing and other materials and other light construction loads onto the cast deck provided that –

- a) the strength of the deck concrete has reached 20 MPa; and
- b) a period of at least 3 days has elapsed since the deck was cast

### 20.2 Construction Loads (Heavy)

Vehicles (multi axle), cranes, compaction equipment, heavy materials and other concentrated loads shall be permitted on the newly cast bridge deck when the concrete has achieved the 28 day characteristic strength and a minimum age of 21 days.

If a proposed construction sequence requires loading of the bridge deck at an earlier age than 21 days, the Contractor shall provide the Administrator with the following information with his/her request for a variation in load timing:

- a) Sufficient test results showing the concrete strength gain at 3, 7, 10 and 14 days for the concrete mix used for the deck. At least five (5) pairs of test cylinders for each of the above ages are required, all from different batches of concrete proposed to construct the bridge deck. The tests must confirm that concrete in the deck will reach the 28 day characteristic strength by the proposed time of loading.
- b) The movement and location of all heavy construction loads including a crane location plan with outrigger positions defined in relation to the bridge deck, and the maximum loads per outrigger for the entire sequence of lifting, turning and lowering the load(s); and
- c) The bridge designer's calculations and certification that the structure can carry these loads within the normal allowable stresses, and without damage or permanent deformation to any bridge deck components.

The Contractor shall submit the proposed loads, the time of the loading and evidence that the strength of the concrete will achieve the 28 day characteristic strength to the Administrator **Hold Point 7**

### **20.3 Legal Traffic Loads**

Operational traffic loads shall be permitted on the deck when the concrete has achieved the 28 day characteristic strength and a minimum age of 21 days. No loading in excess of the design loads shall be permitted on the deck without the approval of the Administrator. **Hold Point 8**

## **21 ANTI-GRAFFITI PROTECTION**

Anti-graffiti protection coatings shall be applied in accordance with the requirements of and in the locations specified in MRTS83 *Anti-Graffiti Protection*.

## **22 SUPPLEMENTARY REQUIREMENTS**

The requirements of MRTS77 *Bridge Deck* are varied by the supplementary requirements given in Clause 8 of Annexure MRTS77.1.