

Main Roads Technical Standard

MRTS15

Noise Fences

June 10

 **Queensland** Government

IMPORTANT INFORMATION

The requirements of this document represent Technical Policy of the department and contain Technical Standards. Compliance with the department's Technical Standards is mandatory for all applications for the design, construction, maintenance and operation of road transport infrastructure in Queensland by or on behalf of the State of Queensland.

This document will be reviewed from time to time as the need arises and in response to improvement suggestions by users. Please send your comments and suggestions to the feedback email given below.

FEEDBACK

Your feedback is welcomed. Please send to mr.techdocs@tmr.qld.gov.au.

COPYRIGHT

© State of Queensland (Department of Transport and Main Roads) 2010

Copyright protects this publication. Except for the purposes permitted by and subject to the conditions prescribed under the Copyright Act, reproduction by any means (including electronic, mechanical, photocopying, microcopying or otherwise) is prohibited without the prior written permission of the department. Enquiries regarding such permission should be directed to the Road & Delivery Performance Division, Queensland Department of Transport and Main Roads.

DISCLAIMER

This publication has been created for use in the design, construction, maintenance and operation of road transport infrastructure in Queensland by or on behalf of the State of Queensland.

Where the publication is used in other than the department's infrastructure projects, the State of Queensland and the department gives no warranties as to the completeness, accuracy or adequacy of the publication or any parts of it and accepts no responsibility or liability upon any basis whatever for anything contained in or omitted from the publication or for the consequences of the use or misuse of the publication or any parts of it.

If the publication or any part of it forms part of a written contract between the State of Queensland and a contractor, this disclaimer applies subject to the express terms of that contract.

June 10

Table of Contents

	Page
1 INTRODUCTION.....	1
2 DEFINITION OF TERMS	1
3 REFERENCED DOCUMENTS	1
4 QUALITY SYSTEM REQUIREMENTS.....	2
5 REGISTERED PRODUCTS.....	2
6 REMOVAL AND SALVAGE OF EXISTING NOISE FENCE.....	3
6.1 General	3
6.2 Components to be Salvaged.....	3
6.3 Location of Storage Site.....	3
6.4 Demolition	3
7 DESIGN.....	3
7.1 General	3
7.1.1 Design Requirements	3
7.1.2 Design Life.....	4
7.1.3 Vandal Resistance.....	4
7.1.4 Rattle.....	4
7.1.5 Acoustic Seal	4
7.1.6 Wind Loading.....	4
7.1.7 Load Combinations.....	5
7.1.8 Minimum Section Properties.....	5
7.2 Steel Posts	5
7.2.1 General	5
7.2.2 Materials	5
7.2.3 Structural Design	6
7.2.4 Serviceability Design	6
7.3 Timber Posts	6
7.3.1 Materials	6
7.3.2 Serviceability Design	6
7.3.3 Structural Design	6
7.3.4 Grading Requirements.....	6
7.3.5 Performance Requirements.....	6
7.3.6 Acceptance	7
7.4 Solid Timber Panels.....	7
7.4.1 Materials	7
7.4.2 Serviceability Design	7
7.4.3 Structural Design	7
7.4.4 Grading Requirements.....	7
7.4.5 Performance Requirements.....	8
7.4.6 Acceptance	8
7.5 Plywood Panels.....	8
7.5.1 General	8
7.5.2 Plywood	8
7.5.3 Manufacture of Plywood	8
7.5.4 Battens.....	9
7.5.5 Serviceability Design	9
7.5.6 Structural Design	9
7.5.7 Performance Requirements.....	9
7.5.8 Sampling and Acceptance	9
7.6 Concrete Panels.....	9
7.6.1 General	9
7.6.2 Materials	9
7.6.3 Cover	10
7.6.4 Manufacture of Reinforced Concrete Panels.....	10
7.6.5 Manufacture of Prestressed Concrete Panels.....	10

7.6.6	Reinforcing Steel.....	10
7.6.7	Serviceability Design.....	10
7.6.8	Structural Design.....	10
7.7	Cementitious Panels	10
7.7.1	General	10
7.7.2	Materials.....	10
7.7.3	Cover.....	10
7.7.4	Reinforcing Steel.....	10
7.7.5	Formwork Removal.....	10
7.7.6	Serviceability Design.....	10
7.7.7	Structural Design.....	11
7.8	Steel Panels	11
7.8.1	General	11
7.8.2	Materials.....	11
7.8.3	Serviceability Design.....	11
7.8.4	Structural Design.....	11
7.9	Transparent Safety Panels.....	12
7.9.1	General	12
7.9.2	Materials.....	12
7.9.3	Serviceability Design.....	14
7.9.4	Structural Design.....	14
7.10	Connectors	14
7.10.1	General	14
7.10.2	Self – Tapping Screws – Timber Posts.....	14
7.10.3	Self – Tapping Screws – Steel Posts.....	14
7.10.4	Bolts, Nuts, Washers – Steel Posts	15
7.10.5	Nails	15
7.10.6	Structural Design.....	15
7.11	Footings	15
7.11.1	General	15
7.11.2	Circular Footings.....	15
7.11.3	Spread Footings.....	16
8	CONSTRUCTION OF NOISE FENCE	16
8.1	General.....	16
8.2	Clearing and Trimming of Trees.....	16
8.3	Disposal of Treated Timber Waste.....	16
8.4	Treatment of Cut Plywood.....	16
8.5	Battens	17
8.6	Footings.....	17
8.7	Batter Restoration	17
8.8	Drainage Slots.....	17
8.9	Backfill to Noise Fence.....	17
8.10	Tolerances	17
8.11	Noise Fences at Property Boundaries.....	18
8.12	Temporary Security Fencing	19
9	SAMPLING AND ACCEPTANCE.....	19
9.1	Timber and Plywood.....	19
9.1.1	General	19
9.1.2	Reporting Requirements	20
9.1.3	Penetration Requirements	20
9.1.4	Retention Requirements	20
9.1.5	Acceptance of Manufacture of Plywood.....	21
9.2	Concrete Panels, Cementitious Panels and Concrete Footings.....	21
9.3	Transparent Safety Panels.....	21
9.3.1	Warranty.....	22
9.3.2	Acceptance of Manufacture of Transparent Safety Panels	22
10	SUPPLEMENTARY REQUIREMENTS	22

Noise Fences

1 INTRODUCTION

This Standard applies to the design and construction of noise fences.

This Technical Standard shall be read in conjunction with MRTS01 *Introduction to Technical Standards*, MRTS50 *Specific Quality System Requirements* and other Technical Standards as appropriate.

This Technical Standard forms part of the Main Roads Specifications and Technical Standards Manual.

2 DEFINITION OF TERMS

The terms used in this Standard shall be as defined in Clause 2 of MRTS01 *Introduction to Technical Standards*.

Where used in this Standard, "TUMA" shall mean the *Timber Utilisation and Marketing Act*.

3 REFERENCED DOCUMENTS

Table 3 lists documents referenced in this Technical Standard.

Table 3 – Referenced Documents

Reference	Title
AS 1111.1	ISO metric hexagon bolts and screws – Product Grade C – Bolts
AS 1112.3	ISO metric hexagon nuts – Product Grade C
AS 1170.1	Structural design actions - Permanent, imposed and other actions
AS/NZS 1170.2	Structural design actions - Wind actions
AS 1214	Hot-dip galvanized coatings on threaded fasteners (ISO metric coarse thread series)
AS 1237.1	Plain washers for metric bolts, screws and nuts for general purposes - General plan
AS 1288	Glass in building – Selection and installation
AS/NZS 1594	Hot-rolled steel flat products
AS/NZS 1605.2	Methods for sampling and analysing timber preservatives and preservative-treated timber – Determination of preservative penetration by spot tests
AS/NZS 1720.1	Timber Structures – Design Methods
AS/NZS 1748	Timber - Mechanically stress-graded for structural purposes
AS/NZS 2208	Safety glassing materials in buildings
AS 2209	Timber – Poles for overhead lines
AS/NZS 2269.0	Plywood – Structural – Specifications
AS 2334	Steel nails - Metric series
AS 2858	Timber - Softwood - Visually stress-graded for structural purposes
AS 3566.1	Self-drilling screws for the building and construction industries – General requirements and mechanical properties
AS 3600	Concrete structures
AS 4100	Steel structures
AS/NZS 4600	Cold-formed steel structures
AS/NZS 4680	Hot-dip galvanized (zinc) coatings on fabricated ferrous articles

Reference	Title
ASTM C158 - 02	Standard Test Methods for Strength of Glass by Flexure (Determination of Modulus of Rupture)
ASTM E111 - 04	Standard Test Method for Young's Modulus, Tangent Modulus, and Chord Modulus
ASTM E424 - 71	Standard Test Methods for Solar Energy Transmittance and Reflectance (Terrestrial) of Sheet Materials
I.S.EN 1794-2	Road Traffic Noise reducing devices – Non-acoustic performance, Part 2: General safety and Environmental Requirements
I.S. EN 7823-1	Plastics – Poly(methyl methacrylate) sheets – Types, dimensions and characteristics – Part 1: Cast Sheets
I.S. EN 1963	Plastics – Polycarbonate sheets – Types, dimensions and characteristics
I.S. EN 13468-2	Plastics – Determination of the total luminous transmittance of transparent materials – Part 2: Double – beam instrument
I.S. EN 527-2	Plastics – Determination of tensile properties – Part 2: Test conditions for moulding and extrusion plastics
I.S. EN 178	Plastics – Determination of flexural properties

4 QUALITY SYSTEM REQUIREMENTS

General requirements for Hold Points, Witness Points and Milestones are specified in Clause 5.2 of MRTS01 *Introduction to Technical Standards*.

The Hold Points, Witness Points and Milestones applicable to this Standard are summarised in Table 4.

Table 4 – Hold Points, Witness Points and Milestones

Clause	Hold Point	Witness Point	Milestone
7.1.1	1. Permission to use noise fence design		Submission of design
7.8.3	2. "Brush" blasting of galvanised panels		
8.2	3. Clearing and trimming of trees		
8.4	4. Treatment of cut plywood		
8.6		Excavation of footings	
9.1.1		Selection of Samples for testing	
9.1.1	5. Assessment of preservative penetration and retention in an independent laboratory.		
9.1.5	6. Supply of certification of the construction of plywood sheeting and supply of test results for timber prior to erection		
9.3.2	7. Supply of test results and warranty statement of transparent safety sheeting		

5 REGISTERED PRODUCTS

Main Roads maintains a register of pre-approved proprietary products for noise fences.

The requirements for noise barrier construction include the use of Main Roads registered suppliers and products for the items listed in Table 5.

Table 5 – Items Requiring Use of Main Roads Registered Suppliers and Products

Clause	Category of Work
7.1.5	Acoustic seals
7.6.4	Reinforced concrete panels
7.6.5	Prestressed concrete panels
7.8	Steel panels – Hot dipped galvanised, weather-resistant and absorptive
7.10.4	Washers for screws
8.4	Preservative treatment of cut plywood above ground

Registered products are listed in Clause 1 of Annexure MRTS15.1. Alternative products may be submitted to the Administrator for approval.

6 REMOVAL AND SALVAGE OF EXISTING NOISE FENCE

6.1 General

Clause 6 describes the work to be carried out where an existing noise fence is to be removed and/or salvaged under the Contract.

6.2 Components to be Salvaged

Sections and components of noise barrier to be salvaged are detailed in Clause 2.1 of Annexure MRTS15.1.

6.3 Location of Storage Site

Salvaged items shall be transported to the storage site nominated in Clause 2.2 of Annexure MRTS15.1.

6.4 Demolition

Noise fence components that are to be removed and/or salvaged under the Contract shall be dismantled and removed with minimum damage to the components regardless of the original construction method.

Footings shall be demolished to a minimum of 0.5 m below ground level and the depression backfilled in accordance with MRTS04 *General Earthworks*. Hollow post sections shall be filled with 'lean mix' concrete.

Salvaged materials shall be directly transported, such that no damage is incurred, to the storage site.

Salvaged materials shall be neatly stacked at the storage site on suitable timber packers.

The remainder of the existing noise fence including non-salvageable materials shall be demolished and disposed of in accordance with MRTS04 *General Earthworks*. Non-salvageable materials include connectors, and all miscellaneous items, eg acoustic seals, etc.

Any materials that have been damaged during the salvage operation shall be rejected. The Contractor shall replace or reimburse the Principal for materials damaged during salvage.

7 DESIGN

7.1 General

7.1.1 Design Requirements

Typical details for noise fences are found in Main Roads Standard Drawings Roads Manual.

Where the design of noise fences is to be undertaken by the Contractor, the Contractor shall prepare and submit detailed drawings and design calculations of the noise fences in accordance with the Contract.

Milestone

The drawings shall clearly state a design wind speed and shall show the location of all footings. Drawings shall be certified as complying with this Standard by a Registered Professional Engineer, Queensland.

Any variation in the vertical alignment of the noise fence shall be shown in longitudinal section on the drawings.

Construction of noise fences shall not commence until the Contractor has been granted permission to use the noise fence design in accordance with the Contract. **Hold Point 1**

Noise fences shall have adequate strength and durability to satisfy the requirements and intentions of the Contract, including this Standard.

Any specific material types required to be incorporated into the Contract are set out in Clause 3 of Annexure MRTS15.1.

7.1.2 Design Life

The design life of noise fences shall be 40 years with minimal maintenance except thermoplastic safety panels. The design life for thermoplastic safety panels shall be 15 years with minimal maintenance.

7.1.3 Vandal Resistance

7.1.3.1 Impact Resistance

Noise fence panels shall be able to withstand the impact of a 4 kg steel ball dropped from a height of 3 metres when the panel is supported horizontally above the ground.

A test panel shall be supported at the ends with a similar edge distance to that used in service. The test panel shall be the worst case of span and width to be used in service.

The impact shall cause only superficial scratches and marks on the panel. The depth of deformation considered to be acceptable is 4 mm within a circle of 20 mm diameter. Cracked or shattered glass panels are not acceptable.

7.1.3.2 Resistance to being Defaced

Noise fences shall exhibit durable properties taking into account such possibilities as –

- a) defacement by sharp implements (eg a knife); and
- b) ignition by cigarettes or similar.

7.1.3.3 Detachment of Panels

Noise fence panels shall not become detached from their supports or fixings when subjected to a load equivalent to 2.5 times the serviceability wind load.

7.1.4 Rattle

Noise fences shall not rattle in any breeze or wind. A durable material shall be placed between all components so that no audible noise emanates from the noise fences.

7.1.5 Acoustic Seal

An acoustic seal shall be provided in any gaps in a noise fence.

Acoustic seals shall be one of the Main Roads registered products (refer Clause 5).

7.1.6 Wind Loading

Design loads on noise fences shall be in accordance with AS/NZS 1170.2, unless modified below –

- a) Wind speeds shall be based on Table 3.1 of AS/NZS 1170.2 using the following return intervals -
 - i. ultimate – 1000 year ARI; and
 - ii. serviceability – 20 year ARI.
- b) Terrain Refer to Clause 4.1 of Annexure MRTS15.1;
- c) Region B or C as defined in Clause 4.2 of Annexure MRTS15.1. Region B shall be used where no region is specified. Region A of AS 1170.2 shall be defined as Region B for the purpose of this Standard;
- d) M_s 1.0;
- e) M_t Refer to Clause 4.3 of Annexure MRTS15.1;

Where noise fences are within 4 metres of the road edge line, the design shall include an additional load of 0.65 kPa representing dynamic suction imposed by moving vehicles for serviceability wind. For noise fences greater than 4.0 m high, the suction load shall only be applied to the lower 4.0 m.

Attention is drawn to the specific requirements of Table D2 of AS/NZS 170.2 for end panels (i.e. 0 to 2h) and internal panels.

7.1.7 Load Combinations

A factor of 1.25 shall be applied to dead load for ultimate load combinations.

7.1.8 Minimum Section Properties

7.1.8.1 All Fence Types

The following minimum section sizes shall apply to the design of all types of noise fences –

- a) Rolled Steel members – 4 mm minimum wall thickness;
- b) Steel Universal Beams – 180UB16 minimum dimension when panel is placed inside a flange; and
- c) Timber posts – 100 mm minimum dimension.

The required thickness to satisfy all conditions shall be stated in the Drawings.

7.1.8.2 Reflective Type Barriers

The following properties shall apply to the panels of reflective type noise barriers –

- a) the minimum surface density of panel materials at air dry moisture content (excluding structural components) shall be 12.5 kg/m²;
- b) the minimum panel thickness for softwood cladding at 8% – 18% moisture content shall be 24 mm for noise attenuation; and
- c) the minimum panel thickness for reflective steel sheets shall be 2.5 mm.

The required thickness to satisfy all conditions shall be stated in the Drawings.

7.1.8.3 Absorptive Type Fences

The following properties shall apply to the panels of absorptive type noise fences –

- a) the Sound Transmission Class shall not be less than 30;
- b) the minimum Coefficient of Absorption shall be as stated in Table 7.1.8.3; and
- c) the absorptive face shall be on the traffic side of the barrier, unless otherwise stated.

Table 7.1.8.3 – Coefficient of Absorption

Sound Frequency (Hz)	Coefficient of Absorption
125	0.5
250	0.8
500	0.9
1,000	0.9
2,000	0.7
4,000	0.6

7.2 Steel Posts

7.2.1 General

Steel posts shall comply with the requirements of Clauses 7.2.1 to 7.2.4, inclusive.

7.2.2 Materials

Materials used in the manufacture of steel posts shall be in accordance with materials referenced in AS 4100 or AS/NZS 4600.

All fabrication shall be in accordance with the requirements of MRTS78 *Fabrication of Structural Steelwork*. All mild steel components shall be hot-dipped galvanised after fabrication in accordance with the requirements of AS/NZS 4680.

The top of closed section steel posts shall be covered by a capping plate, which shall be held in place with a continuous fillet weld. The capping plate shall completely seal the top of the post. Any vent hole provided for hot-dipped galvanising shall be on the vertical face of the erected post and prior to erection, shall be filled with a silicon compatible with galvanised steel.

The fence label and post number shall be identified by welding on the fence post or by a method approved by the Administrator.

7.2.3 Structural Design

Design strength of steel components shall be in accordance with AS 4100 or AS/NZS 4600.

7.2.4 Serviceability Design

The horizontal deflection of the post under serviceability wind shall be limited to –

$$\frac{\text{Height of Barrier}}{150}$$

7.3 Timber Posts

7.3.1 Materials

Timber posts shall be preservative treated softwood seasoned to a moisture content of 20% or below before use and shall conform with the requirements stated in Clauses 7.3.1 to 7.3.6 inclusive.

7.3.2 Serviceability Design

The horizontal deflection of the post under serviceability wind shall be limited to –

$$\frac{\text{Height of Barrier}}{160}$$

7.3.3 Structural Design

Timber posts shall be designed in accordance with AS 1720.1.

7.3.4 Grading Requirements

Softwood structural posts shall be unseasoned strength group S5, or better and shall be –

- a) sawn softwood graded to F11 stress grade in accordance with AS 2858; or
- b) round softwood poles graded to F11 stress grade in accordance with AS 2209.

7.3.5 Performance Requirements

All structural posts shall be treated to Hazard Level 5 (H5) with a proprietary preservative approved under TUMA.

Following treatment, all timber posts shall be stacked outside with strip spacers (not block stacked) for a minimum of 4 weeks prior to usage to –

- a) enable proper fixation of the preservative salts; and
- b) partially season to a lower moisture content, thereby reducing the capacity of the treated timber to cause severe corrosion on metal fixings.

The surfaces of all timber posts shall be free of treatment sludge deposits when the posts are supplied.

Posts shall be supplied to the Site with a nail plate covering a minimum of 80% of each end.

End grain of posts exposed to weather shall be protected by a solid capping or shall be slope cut and an end sealant applied.

On delivery all preservative treated material purporting to comply with this Standard shall be branded in accordance with the requirements of TUMA.

Approved preservative treatments for timber are given in 'Approved Preservative Treatment Notification' issued by the Chief Executive under TUMA.

7.3.6 Acceptance

Timber posts shall be sampled and tested as stated in Clause 9. Acceptance shall be as stated in Clause 9.

7.4 Solid Timber Panels

7.4.1 Materials

All panel timbers, including battens and cladding, shall be preservative treated softwood and shall conform with the requirements stated in Clauses 7.4.1 to 7.4.6, inclusive.

All preservative treated softwood shall be supplied at a moisture content range of 8% – 18%. Material supplied outside this range will be rejected.

Cladding timber boards shall be approximately 150 mm wide and shall have a thickness of 25 mm.

Shiplapped cladding timber boards shall have a minimum lap/rebate of 20 mm so that spring of the timber will not affect the acoustic performance of the noise fence. Paling, timber boards shall have a minimum lap of 25 mm.

The cross-sectional dimensions of battens shall be not less than 70 mm x 35 mm. The maximum spacing of intermediate battens shall be 900 mm for shiplapped profile boards. For tongue and groove panels with a thickness greater than 35 mm and a tongue exceeding 13 mm x 13 mm, the maximum spacing for intermediate battens shall be 1100 mm.

7.4.2 Serviceability Design

The horizontal deflection of the timber panel under serviceability wind shall be limited to –

$$\frac{\text{Span of Panel}}{60}$$

7.4.3 Structural Design

7.4.4 Grading Requirements

Timber fence panels shall be designed in accordance with AS 1720.1.

7.4.4.1 Battens

Structural sawn softwood shall be F5 or better, and either machine stress graded in accordance with AS/NZS 1748, or visually graded in accordance with AS 2858, with the overriding limitations given in Clause 7.4.4.2.

7.4.4.2 Cladding

Softwood cladding shall be visually graded to No 5 structural grade in accordance with AS 2858, with the following overriding limitations –

- a) individual knots (sound, tight, or partial bark encased) shall not exceed one third of the width of the face;
- b) knot holes shall not exceed 20 mm in diameter (as visible after assembly of panels), and no more than two knot holes shall be present in any one cladding board;
- c) heart-in material shall –
 - i. not exceed 20% of the cross-sectional area;
 - ii. not extend from face to face; and
 - iii. not contain pith;
- d) termite galleries shall not be present; and
- e) decay shall not be present.

All knot holes shall be filled with a timber compatible silicon.

7.4.5 Performance Requirements

Any softwood cladding and structural timber not in contact with the ground shall be treated to at least Hazard Level 3 (H3) as specified in TUMA. Any softwood or timber in contact with the ground shall be treated to Hazard Level 4 (H4) as specified in TUMA. The treatment shall be a proprietary preservative approved under TUMA and a proprietary water repellent that penetrates the timber to the same degree as the preservative.

The surfaces of all timber panels shall be free from treatment sludge deposits.

On delivery all preservative treated material purporting to comply with this Standard shall be branded in accordance with the requirements of TUMA.

Approved preservative treatments for timber are given in 'Approved Preservative Treatment Notification' issued by the Chief Executive under TUMA.

7.4.6 Acceptance

Timber panels shall be sampled and tested as stated in Clause 9. Acceptance shall be as stated in Clause 9.

7.5 Plywood Panels

7.5.1 General

Plywood panels shall be preservative treated softwood and shall conform with the requirements stated in Clauses 7.5.1 to 7.5.8, inclusive.

7.5.2 Plywood

Structural plywood shall be Stress Grade F14 or better in accordance with AS/NZS 2269.0.

The grade of veneer on the face and back of panels shall be CC or better in accordance with AS/NZS 2269. Permitted imperfections under this grade may be left unfilled as long as they are within correct size limitations. Plywood veneers shall be as free of heart as possible.

The grade of all core veneers shall be Quality D or better in accordance with AS/NZS 2269.

Plywood panels shall incorporate a proprietary mechanical system that restricts differential movement of the panels. The system shall conform to the service life requirements of the Contract. Edge joints shall have a strong polypropylene tongue and groove jointing system to help prevent warpage and eliminate gaps if movement occurs. The edge strip shall be glued to one panel to ensure that the strip does not move with vibration of the noise fence. Top edge capping, suitably protected against corrosion, shall be attached to the top of the upper panel section.

The bottom sheet of plywood shall be at least 450 mm high.

Plywood shall be supplied kiln dried with a moisture content between 8% and 18%. The finish on both sides of the panel shall be texture wood with slimline grooves to reduce checking of the surface.

After preservative treatment, the dimensions and shape of the plywood shall conform to AS/NZS 2269 criteria.

Plywood panels shall conform to the requirements of reflective type barriers in Clause 7.1.8.2.

7.5.3 Manufacture of Plywood

The minimum requirements for the construction of structural plywood are detailed in Table 7.5.3.

Table 7.5.3 – Plywood Construction

Nominal Thickness (mm)	Identification Code
24	24-24-9
27	27-30-9 / 27-24-11
31	31-24-13

Note: The veneer thicknesses and identification code are as specified in AS/NZS 2269. For example, the identification code 24-24-9 describes 24 mm thick plywood with a nominal face veneer thickness of 2.4 mm of nine plies.

7.5.4 Battens

The batten in cross-section shall not be less than 70 x 35 mm.

A minimum of one batten (mid-span of the panel) shall be provided.

Battens shall conform to the requirements of Clause 7.4.4.1.

7.5.5 Serviceability Design

The horizontal deflection of the panel under serviceability wind shall be limited to –

$$\frac{\text{Span of Panel}}{60}$$

60

7.5.6 Structural Design

Structural design shall be in accordance with AS/NZS 2269 and AS 1720.1.

7.5.7 Performance Requirements

The preservative treatment shall be either veneer treatment or treatment in the final form (envelope).

Plywood panels not in contact with the ground shall be treated to Hazard Level 3 (H3) as specified in TUMA. Only panels that are veneer treated to Hazard Level 4 (H4) as specified in TUMA shall be used for panels in contact with the ground.

For veneer treatment, each veneer shall be treated with a proprietary preservative approved under TUMA. A proprietary water repellent shall be applied to all external surfaces of the plywood panel in the factory; not each veneer.

For treatment in the final form (envelope), panels shall be treated with a proprietary preservative approved under TUMA and a proprietary water repellent that penetrates the plywood to the same degree as the preservative.

Adequate time shall be allowed for fixation of the preservative in the plywood veneers before the panels are kiln dried.

If a plywood panel is to be painted following or before erection, it shall not be treated with proprietary water repellent.

The surfaces of all plywood panels shall be free from treatment sludge deposits.

Untreated material exposed on cutting shall be treated in accordance with Clause 7.4.

On delivery all preservative treated material purporting to comply with this Standard shall be branded in accordance with the requirements of TUMA.

Approved preservative treatments for timber are given in 'Approved Preservative Treatment Notification' issued by the Chief Executive under TUMA.

7.5.8 Sampling and Acceptance

Plywood panels shall be sampled and tested as stated in Clause 9. Acceptance shall be as stated in Clause 9.

7.6 Concrete Panels

7.6.1 General

Concrete panels shall be designed for handling and transport loads equivalent to 50% of the self weight in addition to self weight.

Painting of panels shall be in accordance with Technical Standard MRTS88, *Painting New Work*.

Concrete panels shall comply with the requirements stated in Clauses 7.6.1 to 7.6.8, inclusive.

Concrete panels shall be one of the Main Roads registered products (refer Clause 5).

7.6.2 Materials

Concrete panels shall conform with the requirements for reflective type panels as stated in Clause 7.1.8.2.

Concrete shall conform to MRTS70 *Concrete* unless specified otherwise in Clauses 7.6.3 and 7.6.4.

7.6.3 Cover

The cover requirements shall conform to the requirements of AS 3600. Normal conditions shall have an exposure classification of B1.

7.6.4 Manufacture of Reinforced Concrete Panels

Manufacture of reinforced concrete panels shall be in accordance with MRTS72 *Manufacture of Precast Concrete*.

7.6.5 Manufacture of Prestressed Concrete Panels

Manufacture of prestressed concrete panels shall be in accordance with the relevant requirements of MRTS73 *Manufacture of Prestressed Concrete Deck and Kerb Units*.

7.6.6 Reinforcing Steel

Reinforcing Steel shall conform to the requirements of MRTS71 *Reinforcing Steel*.

7.6.7 Serviceability Design

The horizontal deflection of the panel under serviceability wind shall be limited to –

$$\frac{\text{Span of Panel}}{150}$$

150

7.6.8 Structural Design

Design of concrete components shall be by –

- a) calculation in accordance with AS 3600; or
- b) a recognised test method subject to acceptance by the Administrator. As a minimum, the testing shall satisfy the requirements of Appendix B of AS 3600.

7.7 Cementitious Panels

7.7.1 General

Cementitious panels shall be designed for handling and transport loads equivalent to 50% of the self weight in addition to self weight.

Cementitious panels shall comply with the requirements stated in Clauses 7.7.1 to 7.7.7, inclusive.

7.7.2 Materials

Cementitious panels are defined as having a cement based binder and a filler and do not conform to the requirements of AS 3600.

7.7.3 Cover

The cover to reinforcement shall be sufficient to conform to serviceability and structural design criteria.

7.7.4 Reinforcing Steel

Reinforcing steel shall conform to the requirements of MRTS71 *Reinforcing Steel*. Minimum reinforcement shall be 5 mm bars at 150 mm centres on each face.

All reinforcement shall be hot-dipped galvanised in accordance with the requirements of AS/NZS 4680.

7.7.5 Formwork Removal

Formwork shall not be removed until the cementitious material has attained 60% of the specified 28-day characteristic strength.

7.7.6 Serviceability Design

The horizontal deflection of the panel under serviceability wind shall be limited to –

$$\frac{\text{Span of Panel}}{150}$$

150

All panels in contact with the ground shall be coated with bitumen.

7.7.7 Structural Design

Design of cementitious components shall be by either –

- a) a recognised design method.

In addition to the requirements of the design method, the design shall satisfy the intent of AS 3600 for –

- i. anchorage at the support;
 - ii. restraint of compression reinforcement if the compression reinforcement is used in calculating the bending strength;
 - iii. minimum shrinkage steel requirements; and
 - iv. crack control requirements of slabs; or
- b) a recognised test method subject to acceptance by the Administrator. In addition, the testing shall satisfy the intent of Appendix B of AS 3600.

7.8 Steel Panels

7.8.1 General

Steel panels shall be either hot dipped galvanised or weather-resistant steel panels.

Absorptive and reflective steel panels shall comply with the requirements stated in Clauses 7.8.1 to 7.8.4, inclusive.

Steel panels (absorptive and reflective) shall be one of the Main Roads registered products (refer Clause 5).

Steel panels shall conform to the requirements for reflective type barriers as stated in Clause 7.1.8.2 or the requirements for absorptive type barriers as stated in Clause 7.1.8.3.

Steel panels shall incorporate a proprietary mechanical system that restricts differential movement of the panels. The system shall conform to the service life requirements of the Contract and eliminate air gaps if movement occurs.

Painting of panels shall be in accordance with Technical Standard MRTS88 *Painting New Work*.

7.8.2 Materials

Materials used in the manufacture of absorptive panels shall conform to the requirements of AS/NZS 4100 and 4600.

Materials used in the manufacture of reflective panels shall conform –

- a) to the requirements of AS/NZS 4100 and AS/NZS 4600, or
- b) be weather-resistant steel complying with the requirements of AS/NZS 1594 Grade HW350.

7.8.3 Serviceability Design

The horizontal deflection of the panel under serviceability wind shall be limited to –

Span of Panel

150

Hot-dipped galvanised steel panels shall be galvanised in accordance with the requirements of AS/NZS 4680 with an average coating mass of 600 g/m² on each face. Both sides of the galvanised surface shall be “brush” blasted to reduce glare prior to erection, **Hold Point 2**. “Brush” blasting shall be in accordance with AS/NZS 4680.

The sound insulation of absorptive panels shall be protected from water, rain or road spray. The sound insulation shall be hydrophobic.

Steel panels shall not come in contact with the ground. A concrete sill, 100 mm (minimum) above the ground surface shall be provided. Concrete shall be Class N25/20, in accordance with MRTS70 *Concrete*.

7.8.4 Structural Design

Structural design of absorptive panels shall comply with the requirements of AS/NZS 4600.

Structural design of reflective panels shall comply with the requirements of AS/NZS 4100.

7.9 Transparent Safety Panels

7.9.1 General

Transparent safety panels shall be either toughened laminated safety glass or thermoplastic safety panels.

Thermoplastic safety panels shall be either acrylic or polycarbonate.

Transparent safety panels may be subjected to a change in physical properties due to the effect of UV. Consequently, it is necessary to evaluate transparent safety panels in an "as new" condition and after accelerated ageing to the equivalent 40 years except thermoplastic safety panels. The thermoplastic safety panels shall be evaluated in an "as new" condition and after accelerated aging to the equivalent 15 years.

Special conditions apply to transparent noise fences –

- a) in public areas to ensure they remain intact when accidentally impacted, and
- b) on bridges and elevated structures to ensure that no dangerous pieces are created when the transparent panel is impacted by an errant vehicle.

Transparent panels shall be evaluated as a system consisting of panel, gasket, and restraint/support system and shall specify the source of all components for the panels, including gasket source.

The panels shall conform with the requirements stated in Clauses 7.9.1 to 7.9.4, inclusive.

7.9.2 Materials

7.9.2.1 Toughened Laminated Safety Glass

Toughened Laminated Safety Glass shall conform to AS/NZS 2208 and satisfy the following criteria –

- a) the weight per cubic metre shall be between 24.0 – 26.0 kN/m³;
- b) the coefficient of thermal expansion shall be less than 8.8×10^{-6} mm/m°C to 150°C;
- c) heat soaked;
- d) Grade A to AS/NZS 2208; and
- e) the required optical transmission and strength properties as per Table 7.9.2.1

Table 7.9.2.1 – Optical and Strength Properties of Toughened Laminated Safety Glass

Property	Testing Standard	Minimum Value		
		As New	After 10 years	After 40 years
Light Transmission (thickness 19 mm)	ASTM E424	78%	78%	78%
Modulus of Elasticity	ASTM E111	69 GPa	69 GPa	69 GPa
Tensile Strength at failure	ASTM C158	19 MPa	19 MPa	19 MPa
Flexural Strength at failure	ASTM C158	140 MPa	140 MPa	140 MPa

7.9.2.2 Acrylic

Acrylic shall conform to I.S. EN 7823-1 and satisfy the following criteria –

- a) manufactured from 100% virgin Poly Methyl Methacrylates (PMMA). Colorants, UV adsorbers and pigments may be included up to a total content of 5% and embedded with polyamide threads;
- b) the weight per cubic metre shall be not less than 11.7 kN/m³;
- c) the coefficient of thermal expansion shall be less than 70×10^{-6} mm/m°C to 50°C;
- d) Grade A to AS/NZS 2208;
- e) the Charpy impact strength shall be not less than 8 kJ/m²;

- f) the permanent service temperature shall not be greater than 70°C;
- g) the required optical transmission and strength properties as per Table 7.9.2.2; and
- h) 85% of its light transmission and physical properties for at least 15 years when exposed to weather conditions existing in Queensland;

Table 7.9.2.2 – Optical and Strength Properties of Acrylic

Property	Testing Standard	Minimum Value		
		As New	After 10 years	After 15 years
Light Transmission	I.S. EN 13468-2	90%	88%	85%
Modulus of Elasticity	I.S. EN 527-2	3000 MPa	2700	2500
Tensile Strength at yield	I.S. EN 527-2	70 MPa	65 MPa	62 MPa
Flexural Strength at yield	I.S. EN 178	100 MPa	90 MPa	85 MPa

7.9.2.3 Polycarbonate

Polycarbonate shall conform to I.S. EN 11963 and satisfying the following criteria –

- a) manufactured from 100% Bisphenol A (BPA) and non-phosgene. Colorants, UV absorber and processing aids up to a total of 5% and coated permanently on both sides with a continuous polymeric coating, sheet or film;
- b) the weight per cubic metre shall be not less than 11.8 kN/m³;
- c) the coefficient of thermal expansion shall be less than 65 x 10⁻⁶ mm/m°C to 50°C;
- d) Grade A to AS/NZS 2208;
- e) the charpy impact strength shall be not less than 95 kJ/m²;
- f) the permanent service temperature shall not be greater than 130°C;
- g) the required optical transmission and strength properties as per Table 7.9.2.3; and
- h) 85% of its light transmission and physical properties for at least 15 years when exposed to weather conditions existing in Queensland;

Table 7.9.2.3 – Optical and Strength Properties of Polycarbonate

Property	Testing Standard	Minimum Value		
		As New	After 10 years	After 15 years
Light Transmission	I.S. EN 13468-2	85%	85%	85%
Modulus of Elasticity	I.S. EN 527-2	2200 MPa	2200 MPa	2200 MPa
Tensile Strength at yield	I.S. EN 527-2	65 MPa	65 MPa	65 MPa
Flexural Strength at yield	I.S. EN 178	90 MPa	90 MPa	85 MPa

7.9.2.4 Gaskets

All gaskets shall be Neoprene or EPDM with the following material properties –

- a) hardness = 70°–75° Shore 'A'; and
- b) elongation at break = 200% minimum.

7.9.3 Serviceability Design

7.9.3.1 Optical Properties

Transparent panels shall conform to the requirements of Appendix E and F of I.S. EN 1794–2, for Light Reflection and Transparency respectively.

7.9.3.2 Serviceability Deflection

The horizontal deflection of the toughened laminated safety glass panel under serviceability wind shall be limited to –

$$\frac{\text{Span of Panel}}{80}$$

The horizontal deflection of the acrylic or polycarbonate safety panel under serviceability wind shall be limited to –

$$\frac{\text{Span of Panel}}{60}$$

However, the maximum horizontal deflection for all transparent safety panels under serviceability wind shall be 50mm, but it shall never exceed –

- a) 33 mm when pedestrian areas and the edge line of the road are more than four meters from the panel;
or
- b) 20 mm where the panel is within four meters of pedestrian areas and the edge line of the road.

7.9.4 Structural Design

7.9.4.1 General

This Standard applies only to flat panels supported on –

- a) 4 sides, or
- b) 3 sides and bent on the top side, or
- c) 3 sides and no bend on the top side, or
- d) 2 sides.

Curved sheets are outside the scope of this Standard.

The structural behaviour of panels is heavily influenced by the support method. The Contractor shall demonstrate that the behaviour of the supports conforms to the support fixity assumed by the designer.

7.9.4.2 Design Criteria

The panel shall not dislodge from the support system under ultimate wind.

Structural design of toughened laminated safety glass panels shall be in accordance with AS 1288.

Structural design of acrylic and polycarbonate safety panels shall be a recognised design method.

7.10 Connectors

7.10.1 General

Connectors shall comply with the requirements of Clauses 7.10.1 to 7.10.6, inclusive.

7.10.2 Self – Tapping Screws – Timber Posts

Screws used to connect a noise panel to a timber post shall be 14 gauge type 17 hexagonal head screws with 10 threads per inch, manufactured in accordance with AS 3566.1 and shall have a minimum of 40 micron hot-dipped galvanised or 50 micron mechanical/chemical galvanised corrosion protection over the length of the screw. The Contractor shall provide a manufacturer's test certificate to the Administrator.

7.10.3 Self – Tapping Screws – Steel Posts

Screws used to connect a noise panel to a steel post shall be –

- a) 14 gauge hexagonal head self-drilling screws with a minimum of 20 threads per inch; or
- b) 14 gauge hexagonal head screw (self-tapping or non self-tapping) with 10 threads per inch utilising a 5.8 mm diameter pilot hole within the steel posts, manufactured in accordance with AS 3566.1.

Screws shall have a minimum of 40 micron hot-dipped galvanised or 50 micron mechanical/chemical galvanised corrosion protection over the length of the screw. The Contractor shall provide a manufacturer's test certificate to the Administrator.

7.10.4 Bolts, Nuts, Washers – Steel Posts

All bolts, nuts and washers shall comply with the requirements of AS 1111.1, AS 1112.3 and AS 1237.1, as appropriate. All screws, bolts, nuts and washers shall be hot-dipped galvanised in accordance with AS 1214. All washers shall be hot-dipped galvanised in accordance with AS/NZS 4680.

Washers for screws shall be one of the Main Roads registered products (refer Clause 5).

7.10.5 Nails

All nails shall be flathead nails conforming to AS 2334 and hot-dipped galvanised in accordance with AS 1214.

Nails shall be used only when connecting timber panels together.

7.10.6 Structural Design

All connections shall be designed to adequately secure all members for the design loading.

7.11 Footings

7.11.1 General

Footings shall be designed in accordance with Clauses 7.11.1 to 7.11.3.

Steel posts shall be located at 100 mm (nominal) from the bottom of the footing.

The base of timber posts shall be placed on a 100 mm (nominal) layer of gravel, to prevent ponding of water at the base of the post.

Where a Site-specific geotechnical investigation is available and a detailed geotechnical design has been undertaken, these values shall be used instead of the empirical design method.

The Standard footing design method is based on Brom's theory.

7.11.2 Circular Footings

7.11.2.1 General

The Contractor shall include in the drawings details of the proposed locations and footing depths.

The depth of footings shall be not less than the larger of 1.5 times the footing diameter and 1500 mm.

7.11.2.2 Materials

Concrete in footings shall conform to the requirements of MRTS70 *Concrete* and shall be N25/20, minimum. Concrete cover shall be in accordance with AS 3600. Reinforcing steel shall conform to the requirements of MRTS71 *Reinforcing Steel*.

7.11.2.3 Footing Depth on Flat Terrain

For noise fences less than 4 m high, the design of footings in flat terrain with average ground conditions or better shall be calculated using Brom's formula assuming an average undrained shear strength (C_u) of 50 kPa.

$$L \text{ (depth of footing)} = 1.5d + f + g$$

where -

d = diameter of footing

$$f = \frac{H_u}{9S_u d}$$

$$S_u = \frac{C_u}{1.5}$$

$$g = \sqrt{\frac{M_u}{2.25 S_u d}}$$

H_u = ultimate limit state design for shear

M_u = ultimate limit state design for bending

If the noise fence is greater than 4.0 m high, a geotechnical engineer who is a Certified Professional Engineer (CPEng) shall undertake a detailed design.

7.11.2.4 Footing Depth on Batters

For batters, where the noise fence is less than 4.0 meters high and the post is within five (5) footing diameters of the batter point, the depth of footing shall be adjusted for the effect of the batter in accordance with Table 7.11.2.4. These factors may be changed where a detailed geotechnical assessment has been undertaken.

If the noise fence is greater than 4.0 m high, a geotechnical engineer who is a Certified Professional Engineer (CPEng) or RPEQ shall undertake a detailed design.

Table 7.11.2.4 – Adjustment Factors for 450 mm Diameter Footing on Batters

Slope of Batter (V:H)	Footing Depth for well compacted road embankment
Flat – 1:5	As for flat ground
1:5 – 1:3	1.25 x footing depth for flat ground
1:3 – 1:2	1.5 x footing depth for flat ground
> 1:2	Specialist design required

7.11.3 Spread Footings

7.11.3.1 General

Spread footings shall be designed for a maximum bearing pressure of 100 kPa under serviceability wind.

7.11.3.2 Materials

Concrete in spread footings shall conform to the requirements of MRTS70 *Concrete* and shall be N32/20, minimum. Concrete cover shall be in accordance with AS 3600. Reinforcing steel shall conform to the requirements of MRTS71 *Reinforcing Steel*.

8 CONSTRUCTION OF NOISE FENCE

8.1 General

Noise fences shall be constructed in accordance with the details shown on the drawings.

The noise fence shall be vertical and continuous with no visible air gap between components.

8.2 Clearing and Trimming of Trees

Clearing and trimming of trees and disturbance to surrounding ground are to be minimised. No clearing or trimming of trees shall be carried out unless detailed in the Drawing. **Hold Point 3**

8.3 Disposal of Treated Timber Waste

All treated timber or plywood off-cuts/waste shall be removed from Site daily and disposed of as per local government requirements. Treated timber or plywood shall not be burnt.

8.4 Treatment of Cut Plywood

Where an envelope treated plywood panel is cut on Site 100 mm or more from an edge of a sheet, the cut area shall be treated with one of the Main Roads registered products (refer Clause 5) and applied as per the

manufacturer's requirements. The applied product shall be completely dry before incorporation into the noise barrier works.

Alternatively, the cut plywood panels shall be retreated in accordance with Clause 7.5.7.

Products used for the treatment of cut plywood shall be Main Roads registered products (refer Clause 5). **Hold Point 4** Plywood panels in contact with the ground shall be veneer treated and thus the cut plywood does not have to be retreated. Plywood panels off the ground shall be treated with a product registered for preservative treatment of cut plywood off the ground.

8.5 Battens

Battens shall be fixed to the noise fence panel within 5 days of the panel being erected.

8.6 Footings

The Contractor shall carry out all necessary excavations for footings. **Witness Point**

Posts shall be set in the concrete footing truly vertical and to the dimensions shown on the drawings. The entire top of the concrete footing shall not be lower than ground level and be shaped such that water flows away from the post.

A minimum of 45 mm concrete cover shall be provided from the edge of the footing to the post.

Footings shall be a minimum of 3 days of age prior to fixing the panels.

Between 5 and 7 days after placement of the concrete footing, a compatible silicon sealant shall be placed completely around the interface of a timber post and the concrete footing, to seal cracks due to shrinkage.

8.7 Batter Restoration

Where excavation for foundations on, or adjacent to the batter face results in some over-break of the batter face, the over-break of the batter face shall be backfilled in accordance with the requirements of MRTS04 *General Earthworks*, so that the backfill around the foundations is flush with the adjoining batter surface.

8.8 Drainage Slots

To ensure that the noise fence does not impede natural drainage flow paths, drainage slots shall be constructed at low points along the noise fence, and at the minimum intervals nominated on the drawings. Drainage slots shall be constructed as detailed on the drawings.

Unless detailed on the drawings, where a defined drainage path crosses under the noise fence, as a minimum two drainage slots shall be provided. The drainage slots shall be provided separately in adjoining noise fence panels. One slot shall be located directly over the drainage path, and the other slot shall be provided as close as possible in level to the first slot.

The concrete slab at drainage slots shall be finished flush with the finished ground level, and shall be shaped to suit the natural contours of the surrounding ground. Concrete shall be Class N25/20, in accordance with Technical Standard MRTS70 *Concrete*.

8.9 Backfill to Noise Fence

Unless detailed otherwise, no gap shall be permitted between the bottom of the panel and the ground unless the gap is required for the drainage.

Any backfill against the bottom of a noise barrier shall be of the type specified in and shall be supplied and placed in accordance with MRTS04 *General Earthworks*.

8.10 Tolerances

The tolerances specified in Table 8.10 shall apply to the construction of the noise fences.

Tolerances are permitted to cater for variables caused during manufacture and construction only.

Table 8.10 – Allowable Tolerances

Criteria	Tolerance
Depth of footing	+ 200 mm – 50 mm
Diameter of footing	+ 150 mm – 0 mm
Centre-to-centre distance between posts for panels supported on the outside of the post	+ 50 mm – 200 mm
Centre-to-centre distance between posts for panels supported between the posts	+ 10 mm – 0 mm
Thickness of timber, plywood, concrete and cementitious panels	+ 5 mm – 1 mm
Height and span of panel (excluding Transparent Safety panels)	+ 10 mm – 5 mm
Maximum out-of-verticality of posts	10 mm at any height (maximum)
Maximum out-of-verticality of panels	2 mm/metre
Protective treatment of timber	Refer to Clause 9
Cover to reinforcement	Refer to MRTS71 Reinforcing Steel
Tendon Exit Holes and Formwork End Plates	± 2mm
Tendon Location along Panel	± 5mm
Horizontal Alignment	± 50mm over 3 posts
Hot-dipped galvanising	Refer to AS/NZS 4680
Centre-to-centre distance between supports of Transparent Safety panels	± 10 mm
Thickness of extruded Toughened Laminated Safety Glass panels	± 0.5 mm
Thickness of cast Toughened Laminated Safety Glass panels	+ 15% – 0%
Thickness of Acrylic or Polycarbonate panels	<u>+ 0.5 mm</u>
Height and span of Toughened Laminated Safety Glass panels	± 5 mm
Height and span of Acrylic or Polycarbonate panels	+ 9 mm - 0 mm
Bottom of Clamp Angle Surface Clearance	± 50 mm

8.11 Noise Fences at Property Boundaries

Where an existing property boundary fence requires removal to facilitate construction of the noise fences, the Contractor shall –

- a) remove and dispose of existing fences, walls, footings and other obstructions for a distance of 1 metre inside the property or lesser distance as may be possible to allow construction of the noise fence;
- b) backfill excavations/holes associated with work carried out in (a) above;
- c) perform ground surface treatment including:

- i. supplying, placing and compacting fill material in holes and localised depressions; and
 - ii. adjusting the moisture content of in situ material and compacting material below the existing ground surface.
- d) reinstate side fences to new noise fence fence including supply of any materials;
 - e) supply, erect, dismantle and remove temporary fencing;
 - f) reinstate facilities temporarily removed to facilitate construction of the noise fence; and
 - g) where pools/ponds exist within property, the noise fence shall comply with the pool safety legislation.

If there is any damage to the property including gardens, pools, sheds, lawns, mulching, retaining walls, trees, shrubs, paths drainage and other fixtures and features, the property shall be reinstated to the original condition

8.12 Temporary Security Fencing

Where the existing property boundary fence requires removal to facilitate construction of the noise fences, the Contractor shall liaise with property owners and occupants regarding the location of temporary fencing. The alignment of the temporary fence shall be approved by the property owners.

Temporary security fencing shall be man-proof and a minimum of 1.8 m high chain wire fencing. Materials shall be as shown on Standard Drawing No. 1602.

The Contractor may use "removable concrete shoes" in lieu of the permanent concrete footings shown on Standard Drawing No. 1602, provided that the temporary security fence is securely fixed in position and adequately tied down against storm damage.

Temporary fencing shall be erected prior to the removal of the existing fences or noise fences in order to maintain the security and protection of private properties and the occupants, or the livestock. The temporary fence shall be located approximately 1 m offset inside the private property where possible. The alignment of the fence shall deviate to avoid fixed objects and trees.

A shade cloth or equivalent shall be installed on the inside face of the temporary security fence to provide visual privacy to the occupants.

The temporary fencing shall only be removed upon completion of the noise fence, or property being secured otherwise by permanent fencing. During the progress of the Works the Contractor shall dismantle and re-erect temporary fencing as necessary to maintain the security of private properties and the occupants. On completion of the Works all temporary fencing shall be dismantled, removed from Site and disposed of by the Contractor.

Temporary fencing shall comply with the pool safety legislation.

9 SAMPLING AND ACCEPTANCE

9.1 Timber and Plywood

9.1.1 General

All preservative treated material purporting to comply with this Standard shall be sampled to determine compliance. The Contractor shall order sufficient extra material to obtain samples for testing.

The Contractor shall give the Administrator not less than 24 hours notice of when sample selection is to occur. **Witness Point** For the purpose of this Standard, a lot is defined as the timber and plywood of the same size from one supplier that has been treated in the same chemical treatment charge.

The number of pieces to be sampled and tested by the Contractor shall be 5% of a lot. Where there is less than 20 pieces in a lot, a minimum of one piece shall be tested.

Timber or plywood to be tested shall be randomly selected from a lot. In the case of solid timber, swatches shall be at least 600 mm long and include the end of a piece. In the case of plywood, the test piece shall be sampled as illustrated by the hatched area in Figure 9.1.1 with the cut faces clearly identified.

Table 9.1.1 – Area to be Sampled when Testing Plywood

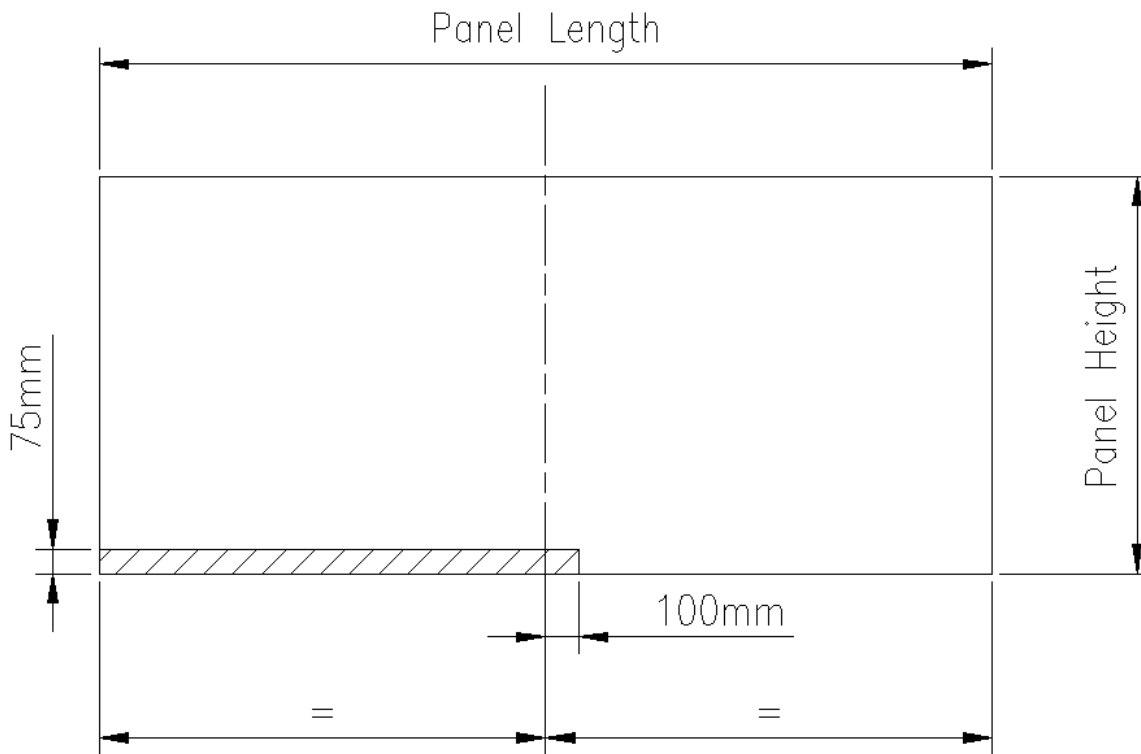

Assessment of preservative penetration and retention shall be undertaken in an independent laboratory.

Hold Point 5

9.1.2 Reporting Requirements

In addition to the reporting requirements of AS/NZS 1605, all test certificates shall include the following information for each sample tested –

- a) supplier's sample identification;
- b) test element
- c) test result for each element (% of each chemical for retention and 'Satisfactory/Unsatisfactory' for Sapwood and Heartwood penetration);
- d) overall Test Outcome (Pass or Fail TUMA); and
- e) TUMA requirements for each Hazard Level tested.

9.1.3 Penetration Requirements

Samples shall be tested for preservative penetration. Assessment of preservative penetration shall be in accordance with either of the methods specified in Clauses 1.7.1 or 1.7.2 of AS/NZS 1605.2. Failure to pass the penetration requirements of TUMA will be deemed to be a "failure" for that lot.

The lot shall be rejected if less than 95% of the samples pass the penetration requirements of TUMA.

9.1.4 Retention Requirements

9.1.4.1 General

Subject to the preservative retention meeting all requirements set out in this Standard it will be accepted or rejected on a statistical basis using the results of tests as set out below.

Preservative retention in a lot shall be rejected if either of the following apply –

- a) any preservative retention test result is less than 90% of the minimum preservative retention specified in TUMA for that Hazard Class; or

- b) the average preservative retention of any three samples from the lot is less than the minimum preservative retention specified in TUMA for that Hazard Class.

In addition, where 10 or more samples of a particular lot represented by these shall be rejected if the average preservative retention level of all the tests for the job is less than –

$$0.5(P_{\text{Min}} + P_{\text{Target}})$$

Where:

P_{Min} = TUMA minimum preservative retention level

P_{Target} = Target preservative retention level (Refer Clause 9.1.4.2)

9.1.4.2 Target Preservative Retention Level

The minimum target preservative retention level shall be calculated from the equation –

$$P_{\text{Target}} = P_{\text{Min}} + 1.65 s$$

Where, s = standard deviation of all the results for the job.

Where adequate plant records are available, the current standard deviation for the similar preservative retention levels may be used but it shall not be less than 0.08 P_{Min} .

Where adequate plant records are not available an estimated value of standard deviation shall be used which is not less than 0.12 P_{Min} or greater than 0.20 P_{Min} depending on the degree of quality control nominated.

9.1.5 Acceptance of Manufacture of Plywood

Prior to erection of any preservative treated materials, the Contractor shall supply certification of the manufacture of the plywood sheeting, as stated in Clause 7.5.3 and a copy of all test results to the Administrator. **Hold Point 6**

9.2 Concrete Panels, Cementitious Panels and Concrete Footings

The Contractor shall carry out sufficient testing to ensure that all concrete panels, cementitious panels and concrete footings constructed under the Contract comply with the requirements of this Standard.

Process requirements shall be checked during and after the construction operation, as relevant.

Sampling and acceptance of concrete shall be in accordance with MRTS70 *Concrete* except that the minimum rate of sampling shall be –

- a) 2 cylinders per day where the production rate exceeds 5 m³ per day; and
- b) 2 cylinders per two days where the production rate is equal to or less than 5 m³ per day.

9.3 Transparent Safety Panels

The Contractor shall carry out sufficient testing to ensure that the transparent safety panels comply with the requirements of the Standard.

Sampling and acceptance for transparent safety panels shall be in accordance with Table 9.3.

Table 9.3 – Sampling Requirements for Transparent Safety Panels

Test	Frequency
Height and span of panel:	
Extruded sheet	1 in 50 sheets
Cast Sheet	1 in 2 sheets
Thickness of panel:	
Extruded sheet	Every 100 m of production (min. of 1 sample per project)
Cast Sheet	Every sheet
Optical transmission and strength properties	1 in 100 sheets

9.3.1 Warranty

The Contractor shall provide to the Administrator a Performance Warranty Statement from the transparent safety sheet manufacturer. The transparent safety panel shall remain in good condition except for accidental damage or vandalism for the period specified in Clause 7.9. Good condition is defined as –

- a) No evidence of cracking; crazing; peeling; delamination blistering; chalking; wrinkling; bubbling; or edge shrinkage greater than 2 mm; and
- b) No evidence of visible or visual defects, inclusions or faults that can be seen from a moving vehicle under normal or night driving conditions by a driver with normal vision.

9.3.2 Acceptance of Manufacture of Transparent Safety Panels

Prior to erection of any transparent safety panels, the Contractor shall supply a copy of all test results and warranty statement, as stated in Clause 9.3.1 to the Administrator. **Hold Point 7**

10 SUPPLEMENTARY REQUIREMENTS

The requirements of MRTS15 *Noise Fences* are varied by the supplementary requirements given in Clause 5 of Annexure MRTS15.1.