

# Part 7 Railway Crossings

---

## 2003 Edition

First Issue 1st August, 2003

Second Issue 25th May, 2009



Queensland Government

NOTE: This may be a low-resolution file intended for on-screen viewing only. This file cannot be printed.

This file may be one part of a complete technical publication, and should not be read in isolation of the other parts of the publication.

A full-resolution version of all parts of the publication can be obtained from the Department of Transport and Main Roads. [www.tmr.qld.gov.au](http://www.tmr.qld.gov.au)  
The Department of Transport and Main Roads takes no responsibility for any loss or damage resulting from the use of this low-resolution file.

(Blank)

## PREFACE

The use of signs, markings and other devices at railway level crossings, based on uniform standards and practices, is essential in the interests of safety for both rail traffic and road users. This Part of the Manual of Uniform Traffic Control Devices sets out the various controls used at railway, cane railway and combined railway/cane railway level crossings and describes the devices and assemblies, their use and location to achieve these controls.

The principal changes and additions to the previous issue are summarised as follows:

- (a) This Part of the Manual now promotes use of the red background position sign, R6-25, for new or replacement signs in preference to the open 'crossbuck' sign, R6-24.
- (b) Provision is made for active advance warning of the activation of railway crossing signals under certain conditions.
- (c) More detail is given for sight distance requirements at passive control crossings for stop and give-way sign control.
- (d) The need to avoid unsafe queuing of traffic on railway crossings upstream of traffic signals is recognized and the use of corrective measures including signs and box markings are specified.
- (e) Standards for pedestrian crossing treatments at railway crossings have been substantially upgraded and now include provision for people with disabilities.

### Version History: 2003 Edition

First Issue 1st August, 2003

Second Issue 25th May, 2009

## CONTENTS

SECTION 1. SCOPE AND GENERAL .....	7-6
1.1 SCOPE .....	7-6
1.2 APPLICATION .....	7-6
1.3 REFERENCED DOCUMENTS .....	7-6
1.4 DEFINITIONS .....	7-6
1.5 CO-OPERATION BETWEEN AUTHORITIES .....	7-7
1.6 RESTRICTED ACCESS ROAD VEHICLES .....	7-7
SECTION 2. SIGNS, DEVICES AND ASSEMBLIES - DESCRIPTION AND USE .....	7-8
2.1 GENERAL.....	7-8
2.2 PASSIVE CONTROL DEVICES .....	7-10
2.3 ACTIVE CONTROL DEVICES .....	7-14
2.4 DEVICES USED AT EITHER ACTIVE OR PASSIVE CONTROL CROSSINGS .....	7-19
SECTION 3. PAVEMENT MARKINGS .....	7-21
3.1 GENERAL.....	7-21
3.2 RAILWAY CROSSING PAVEMENT MARKING (RAIL X).....	7-21
3.3 STOP LINE .....	7-21
3.4 GIVE-WAY LINE .....	7-21
3.5 NO-OVERTAKING LINES .....	7-21
3.6 BOX MARKINGS .....	7-24
SECTION 4. APPLICATION OF SIGNS AND MARKINGS TO RAILWAY CROSSINGS.....	7-25
4.2 PASSIVE CONTROL TREATMENTS .....	7-25
4.3 ACTIVE CONTROL TREATMENTS .....	7-27
4.4 MODIFIED TREATMENTS.....	7-27
4.5 STOP SIGNS AT COMBINED ROAD/RAIL CROSSINGS .....	7-28
4.6 TEMPORARY AND EMERGENCY CONTROL .....	7-28
4.7 CLOSURE OF A RAILWAY LINE .....	7-28
SECTION 5. AVOIDANCE OF TRAFFIC QUEUING ON CROSSINGS .....	7-40
5.1 GENERAL.....	7-40
5.2 ELIMINATING THE PROBLEM.....	7-40
5.3 TREATMENT WITH WARNING DEVICES AND REFUGES .....	7-40
5.4 SHORT STACKING .....	7-40
SECTION 6. PEDESTRIAN AND BICYCLE TREATMENTS AT RAILWAY CROSSINGS.....	7-41
6.1 GENERAL.....	7-41
6.2 HIERARCHY OF CONTROL.....	7-41
6.3 CROSSING ELEMENTS - DESIGN AND PERFORMANCE REQUIREMENTS .....	7-41
6.4 PEDESTRIAN HOLDING MARKINGS .....	7-44
6.5 SIGNS AND SIGNALS.....	7-44
6.6 FACILITIES FOR BICYCLES .....	7-46
SECTION 7. CANE RAILWAY CROSSINGS .....	7-47
APPENDICES	
A ILLUMINATION AND REFLECTORIZATION OF SIGNS .....	7-48
B INSTALLATION AND LOCATION OF SIGNS .....	7-49
C SELECTION OF APPROPRIATE SIGN SIZE .....	7-50
D SIGHT DISTANCE PROVISION AT PASSIVE CONTROL CROSSINGS .....	7-51
E ACTIVE ADVANCE WARNING ASSEMBLY-GUIDES FOR USE, INSTALLATION AND OPERATION .....	7-56
F PEDESTRIAN FACILITIES - TYPICAL EXAMPLES .....	7-59

## FOREWORD

Uniform standards and practices in the use of signs, markings and other devices at railway crossings is essential in the interests of safety for both rail traffic and road users.

Essential to this compliance is an understanding of the risks inherent at railway crossings. Long, heavy freight trains and high-speed passenger trains constitute a massive energy source that can be highly destructive. Trains, even those moving relatively slowly, cannot be stopped anywhere near as readily as road traffic and this factor may not be apparent to some road users. It is imperative that vehicle occupants do not come into contact with such large energy sources and that road users recognize the need and are given every opportunity to give way to trains.

Problems associated with long and heavy road vehicles can influence both the location and safe operation of crossings. Long and heavy vehicles with slow acceleration from the stopped position can, when sight distance along the railway is poor, have difficulty starting up and clearing a crossing before the arrival of a previously unseen train unless there is some form of active control to warn that a train is coming. Likewise, long vehicles can present problems if there is an intersection or other vehicular check point close to the crossing on the departure side and the rear of such a vehicle inadvertently fails to clear the conflict area. Appropriate solutions need to be considered for all of these conditions.

Before any works, features or devices (e.g. pedestrian crossing, bus stop, intersection control, temporary works site) are introduced in the vicinity of a railway crossing, which could cause road traffic to queue across the crossing, the relevant rail and road authorities should confer to determine the most suitable method of handling the situation.

Other problems such as ill-defined crossings which may occur within freight loading areas, and crossings which are only used seasonally or indeed very rarely at any time of the year may present operational and management challenges that can only be partially met (if at all in some cases) by application of this Part of the Manual.

Railway crossings should be located to avoid sub-standard geometric features of the road, such as sub-standard curves, reduced pavement widths and vertical obstructions. If this cannot be avoided, special attention should be given to the signing and marking of these features as well as the railway crossing itself. Sub-standard geometric features can lead to increased numbers of crashes not involving trains as well as having an effect on the incidence of vehicle/train collisions.

This Part of the Manual does not provide guidance on when a crossing should progress from one hierarchical step in the type of control to the next, i.e. passive control to active control and active control to elimination. Such guidance can be found in risk assessment models such as ALCAM\*.

---

\* Australian Level Crossing Assessment Model

---



---

**DEPARTMENT OF TRANSPORT AND MAIN ROADS  
Queensland**

---

**Manual of Uniform Traffic Control Devices**

---

**PART 7 – RAILWAY CROSSINGS**

**SECTION 1. SCOPE AND GENERAL**

**1.1 SCOPE**

This Part of the Manual specifies traffic control devices to be used to control and warn traffic at and in advance of railway crossings at grade. It specifies the way in which these devices are used to achieve the level of traffic control required for the safety of rail traffic and road users, including pedestrians. Requirements and guidance are also given in appendices on the illumination and reflectorization of signs, on their installation and location, and on selection of the appropriate sign size.

**1.2 APPLICATION**

The requirements of this Part of the Manual are applicable to crossings on private land, which may be used by other members of the general public to access other infrastructure outside the boundaries of the land.

The requirements of this Part of the Manual are not applicable to railway crossings located within the boundaries of private land provided for the exclusive use of the owner (or by other users with the knowledge and agreement of the owner) for the in-farm movement of agricultural, harvesting and associated machinery. Access roadways to private land crossing a cane railway within the road boundaries are also exempt.

**1.3 REFERENCED DOCUMENTS**

The following documents are referred to in this Part:

**AS**

- 1428 Design for access and mobility
- 1428.1 Part 1: General requirements for access - New building work
- 1743 Road signs - Specification

**AS/NZS**

- 1158 Lighting for roads and public spaces
- 1158.3.1 Part 3.1: Pedestrian area (Category P) lighting - Performance and design requirements
- 1428 Design for access and mobility
- 1428.4 Part 4: Tactile indicators
- 1906 Retroreflective materials and devices for road traffic control purposes
- 1906.1 Part1: Retroreflective materials
- 2144 Traffic signal lanterns
- HB 197 An introductory guide to the slip resistance of pedestrian surface material

**1.4 DEFINITIONS**

For the purpose of this Part of the Manual, the definitions below apply.

**1.4.1 Active control**

Control of the movement of vehicular or pedestrian traffic across a railway crossing by devices such as flashing signals, gates or barriers, or a combination of these, where the device is activated prior to and during the passage of a train through the crossing.

### 1.4.2 Light rail

Urban public transport systems comprising railed vehicles, i.e. trams, which commonly but not necessarily travel on streets intermingling with road traffic, and maintain separation from other traffic by line of sight.

### 1.4.3 Passive control

Control of the movement of vehicular or pedestrian traffic across a railway crossing by signs and devices, none of which are activated during the approach or passage of a train, and which rely on the road user including pedestrians detecting the approach or presence of a train by direct observation.

### 1.4.4 Pedestrians

People travelling on foot or using mobility aids (e.g. wheelchair, scooters) or walking with bicycles, baby carriages or animals.

### 1.4.5 Railway

A guided track system together with associated infrastructure designed for the movement of rolling stock and includes a heavy railway, a light railway, an inclined railway or a cane railway, having a nominal gauge in each case of not less than 600 mm.

### 1.4.6 Railway crossing

Any crossing of a railway at grade, providing for both vehicular traffic and other road users including pedestrians.

### 1.4.7 Traffic control device

Any sign, signal, pavement marking or other installation placed or erected under authority of the Transport Operations (Road Management) Act, for the purpose of regulating, warning or guiding road users.

### 1.4.8 85th percentile speed ( $V_{85}$ km/h)

The speed at or below which 85 percent of vehicles are observed to travel under free-flowing conditions past a nominated point. A vehicle is considered to be operating under free-flowing conditions when the preceding vehicle has at least four seconds headway and there is no apparent attempt to overtake the vehicle ahead.

NOTE: For the purpose of this Part of the Manual, it is normal to include all types of vehicles on the road and to aggregate the results of measurements unless specifically noted otherwise. It is desirable to make speed measurements by unobtrusive means. A detailed guide to the determination of 85th percentile speed is given in Part 4 of the Manual.

## 1.5 CO-OPERATION BETWEEN AUTHORITIES

Attention is drawn to the need for meaningful cooperation on maintenance and safety issues at railway crossings between the relevant road and railway authorities. The safety of railway users is heavily dependent among other things, on the successful control and guidance of road users approaching a crossing. Equally the safety of road users is dependent on their ability to detect the approach of a train. Although the responsibility for provision and maintenance of various traffic control devices may be split between authorities, there needs to be coordination of both maintenance and safety audit activities. Any changes in infrastructure or operation contemplated by one authority that may increase the risk associated with operation of the crossing, need to be agreed to by the other.

## 1.6 RESTRICTED ACCESS ROAD VEHICLES

This Part of the Manual applies generally to the use of railway crossings by standard road vehicles of the types permitted unrestricted access under applicable traffic regulations. If restricted access vehicles (e.g. road trains) or vehicles operating under permit (e.g. overdimensional vehicles) are to be allowed to use a railway crossing, requirements for the safe operation of the crossing may need to be modified or any increased risk managed in another appropriate way.

## SECTION 2. SIGNS, DEVICES AND ASSEMBLIES - DESCRIPTION AND USE

### 2.1 GENERAL

Standard assemblies of signs and devices used at railway crossings are designated in the series RX-1 to RX-12, and are listed in Table 2.1. Where flashing signals are used at a crossing, they are shown as an element of the appropriate assembly. Signs used either alone or as components of these assemblies are listed in Table 2.2.

The description and use of signs and assemblies is given as follows:

- (a) *Passive control devices* Clause 2.2.
- (b) *Active control devices* Clause 2.3
- (c) *Devices used in either form of control* Clause 2.4.

Guidance on the illumination and reflectorization of signs and assemblies, their location and the selection of the appropriate sign sizes, is given in Appendices A, B and C, respectively. Specific requirements for the reflectorization of certain signs in the immediate vicinity of railway crossings are given in Appendix A.

Detailed specifications for the manufacture of signs are given in AS 1743.

**TABLE 2.1 ASSEMBLIES USED AT RAILWAY CROSSINGS**

Assembly	Assembly designation	Signs incorporated	Reference Clause
Railway crossing GIVE WAY assembly	RX-1	R6-24 or R6-25, W7-2-1 or W7-2-2, R1-2	2.2.1
Railway crossing STOP assembly	RX-2	R6-24 or R6-25, W7-2-1 or W7-2-2, R1-1, G9-48	2.2.2
Railway crossing diagrammatic warning assembly with LOOK FOR TRAINS	RX-3-1 RX-3-2 RX-3-3	W7-8, G9-48 W7-9(L), G9-48 W7-9(R), G9-48	2.2.4
Railway crossing ON SIDE ROAD assembly- Passive control crossing	RX-4	W7-7(L), W8-3(L or R)	2.2.5
Railway crossing flashing signal assembly	RX-5	R6-24 or R6-25, W7-2-1 or W7-2-2, R6-9	2.3.1
Railway crossing gate position assembly	RX-6	R6-24 or R6-25, W7-2-1 or	
W7-2-2 (beside gates); R6-8 (on gates)	2.3.2		
Railway crossing flashing signal ahead ON SIDE ROAD assembly	RX-7	W7-4, W8-3(L or R)	2.3.5
Railway crossing RAILWAY GATE, ON SIDE ROAD assembly	RX-8	W7-15, W8-3(L or R)	2.3.6
Railway crossing width marker assembly	RX-9	G9-32, G9-33, D4-3 (L and R)	2.4.2
Railway crossing x m (km) ahead - Passive control crossing	RX-10	W7-7(L), W8-5	2.2.3
Railway crossing flashing lights active advance warning signal assembly	RX-11	W7-4, W8-27	2.3.7
Red symbolic standing pedestrian signal	RX-12		6.5.3

**TABLE 2.2 SIGNS USED AT RAILWAY CROSSINGS**

Sign	Sign number	Size, mm	Used in assembly
STOP	R1-1A R1-1B	600 × 600 750 × 750	RX-2
GIVE WAY	R1-2A R1-2B	750 (ht) 900 (ht)	RX-1
NO ENTRY	R2-4	300 × 300*	RX-6
STOP (gate sign)	R6-8C R6-8D	750 (dia) 900 (dia)	RX-6
STOP ON RED SIGNAL	R6-9	450 × 600	RX-5
RAILWAY CROSSING position	R6-24A	1350 × 178 each crossarm	RX-1 RX-2
(Number) ...TRACKS	W7-2-1A W7-2-1B	600 × 275 800 × 367	RX-5 RX-6
RAILWAY CROSSING position (with target board)	R6-25A R6-25B	Not used 1350 × 900	RX-1 RX-2
(Number) ... TRACKS	W7-2-2A	1000 × 150	RX-5 RX-6
TRAMWAY CROSSING position	R6-26	1350 × 178 each crossarm	
Stop Sign Ahead	W3-1A W3-1B W3-1c	600 × 600 750 × 750 900 × 900	
Railway Crossing Flashing Signals Ahead	W7-4A W7-4B W7-4C	Not used 750 × 750 900 × 900	Alone and RX-11
Railway Crossing (passive control) Ahead-Symbolic Train	W7-7A (L, R) W7-7B (L, R) W7-7C (L, R)	600 × 600 750 × 750 900 × 900	Alone and RX-10
Railway Crossing Ahead Diagrammatic			
- Right Angle Crossing	W7-8A, B, C	600 × 600	RX-3
- Oblique Crossing	W7-9 (L, R)A, B, C	750 × 750	
- Crossing on Side Road	W7-12A, B, C	900 × 900	
- Crossing on Cross Road	W7-13A, B, C		
- Crossing on Bar of T-junction	W7-17(L,R) A, B, C		
Railway Crossing Pedestrian Warning			
- Look for trains, (number) tracks	W7-14-4	300 × 450	
- Look for trains	W7-14-5	300 × 450	
- Do not cross while...	W7-14-6	450 × 500	
RAILWAY GATE	W7-15A W7-15b W7-15C	600 × 600 750 × 750 900 × 900	RX-8
ON SIDE ROAD	W8-3A W8-3B W8-3C	600 × 600 750 × 750 900 × 900	RX-4 RX-7 RX-8
(Distance) ... m	W8-5A W8-5B W8-5C	Not used 750 × 250 900 × 300	RX-10

NOTE: This may be a low-resolution file intended for on-screen viewing only. This file cannot be printed.

This file may be one part of a complete technical publication, and should not be read in isolation of the other parts of the publication.

A full-resolution version of all parts of the publication can be obtained from the Department of Transport and Main Roads. [www.tmr.qld.gov.au](http://www.tmr.qld.gov.au)  
The Department of Transport and Main Roads takes no responsibility for any loss or damage resulting from the use of this low-resolution file.

**TABLE 2.2 SIGNS USED AT RAILWAY CROSSINGS**

Sign	Sign number	Size, mm	Used in assembly
RAILWAY CROSSING	G9-32 G9-33	2100×450 2100×450	RX-9
LOOK FOR TRAINS	G9-48A G9-48B G9-48C	600 × 600 750 × 750 900 × 900	RX-2 RX-3
Cyclists Dismount	G9-58A	450 × 450	
KEEP TRACKS CLEAR	G9-67-1A G9-67-1B	600 x 600 750 x 750	
KEEP TRACKS CLEAR (box marking)	G9-67-2	600 x 1200	
Emergency Exit, Push Gate	G9-68	400 x 300	
RAILWAY CROSSING NOT IN USE	G9-74	750 x 600	
Width marker	D4-3 (L or R)	450 x 900	RX-9
Chevron Alignment marker	D4-6A D4-6B D4-6C	600 x 750 750 x 900 900 x 1100	

**2.2 PASSIVE CONTROL DEVICES**

**2.2.1 Railway crossing give-way assembly (RX-1)**

The RX-1 assembly shall be used at railway crossings controlled by GIVE WAY signs (see Clause 4.2). Its upper sign shall be either the R6-24 or the R6-25 sign.

NOTE: For new or refurbished RX-1 assemblies, the R6-25 sign is to be preferred. The sign should be the same on all assemblies facing any one approach to the crossing.

It is located on the left side of the roadway at the point at which vehicles must stop if a train is approaching. On divided roads it will usually be necessary to repeat the RX-1 assembly on the median. A give-way line shall be used on sealed pavements to define further the safe stopping position (see Clause 3.4).

Sign W7-2-1 or W7-2-2, (Number) ... TRACKS, shall be used at all multiple track crossings.



R6-24

W7-2-1

R1-2

RX-1 (incorporating sign R6-24)



R6-25

W7-2-2

R1-2

RX-1 (incorporating sign R6-25)

**2.2.2 Railway crossing stop assembly (RX-2)**

The RX-2 assembly shall be used at a railway crossing where the requirements of Clause 4.2 indicate that the crossing is to be controlled by STOP signs. Its upper sign shall be either the R6-24 or the R6-25 sign.

NOTE: For new or refurbished RX-2 assemblies, the R6-25 sign is to be preferred. The sign should be the same on all assemblies facing any one approach to the crossing.

It is located on the left side of the roadway at the point at which vehicles are required to stop. On divided roads it will usually be necessary to repeat the RX-2 assembly on the median.

Sign W7-2-1 or W7-2-2, (Number) ... TRACKS, shall be used at all multiple track crossings.

A stop line shall be used on sealed roads in conjunction with the RX-2 assembly (see Clause 3.3).

A Stop Sign Ahead sign (W3-1) is normally required (see Clause 2.2.7).

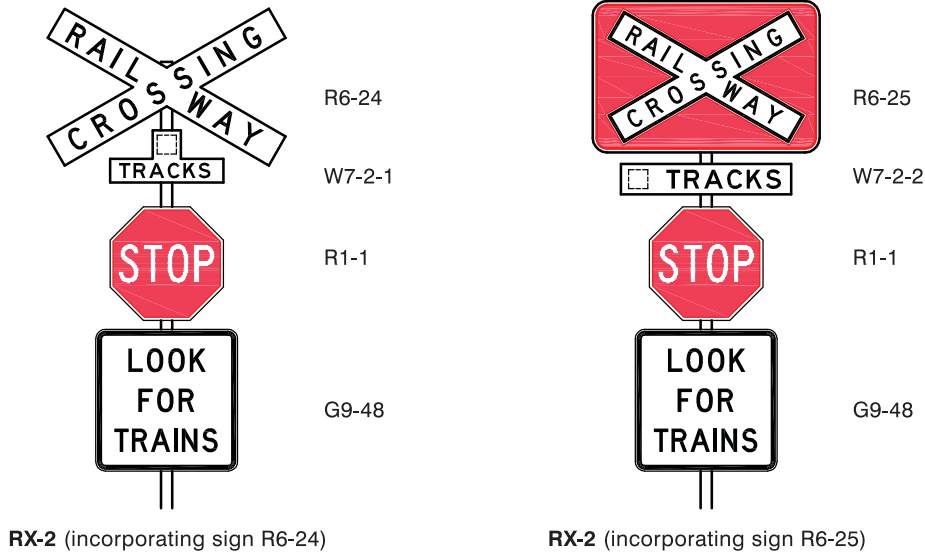

**2.2.3 Railway crossing ahead - Passive control (W7-7, RX-10)**

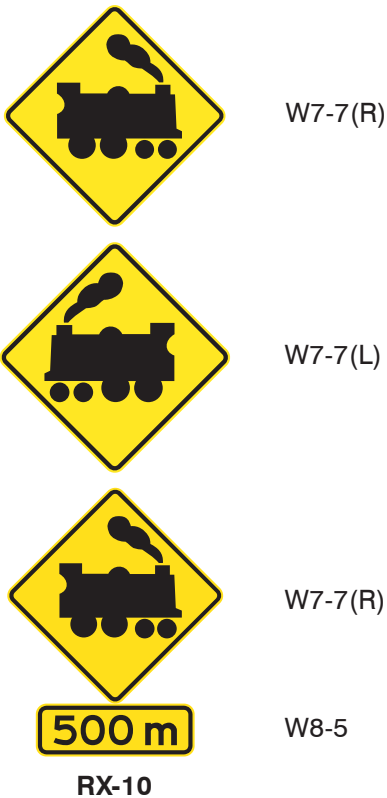

The W7-7 sign is used to give advance warning of a railway crossing controlled by passive devices, i.e. GIVE WAY signs or STOP signs. It shall be used as the first warning device encountered, except where long distance advance warning signs are used (see below), or where this Part of the Manual specifically exempts crossings from the need for advance signs (see Clauses 4.2.2 and 4.4.2).

Where a single sign is adequate, the W7-7(R) sign shall be placed on the left side of the carriageway. Where the sign needs to be repeated on the right-hand side of the road for added emphasis, e.g. on a high volume road or on a left hand curve, the W7-7(L) sign shall be used.

If long distance advance warning is required, the RX-10 assembly should be used to show the distance to the crossing, typically 500 m to 1 km on a high speed rural road. This assembly, if used, shall be additional to and not replace the W7-7 signs required in the standard positions indicated above.

The assembly used where the crossing is on a side road is described in Clause 2.2.5.

NOTE: This may be a low-resolution file intended for on-screen viewing only. This file cannot be printed. This file may be one part of a complete technical publication, and should not be read in isolation of the other parts of the publication. A full-resolution version of all parts of the publication can be obtained from the Department of Transport and Main Roads. www.tmr.qld.gov.au The Department of Transport and Main Roads takes no responsibility for any loss or damage resulting from the use of this low-resolution file.

**2.2.4 Railway crossing diagrammatic warning assemblies (RX-3-1, RX-3-2 and RX-3-3)**

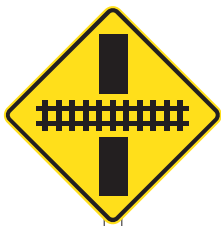

W7-8



G9-48

**RX-3-1**



W7-9(L)



G9-48

**RX-3-2**



W7-9(R)



G9-48

**RX-3-3**

The diagrammatic warning assembly shall be used as the second or intermediate sign in advance of railway crossings controlled by GIVE WAY signs, except where this Part of the Manual specifically exempts W7-8 crossings from the need for advance signs (see Clauses 4.2.2 and 4.4.2). It is located between the first advance warning sign (W7-7) and the crossing.

The assembly is generally required on the left side of the carriageway only, unless it needs to be repeated on the right side for added emphasis or visibility. Assemblies are used as follows:

- (a) RX-3-1 is used on a straight approach where the railway crosses the road substantially at right angles.
- (b) RX-3-2 and RX-3-3 are used on a straight approach where the railway crosses the road obliquely such that road users need to be warned to adjust the directions in which they should look for approaching trains.

If the road or railway or both curve near the crossing such that the direction in which a driver should search for oncoming trains is different from the direction of the rails at the crossing, the assembly should be selected which most clearly indicates the direction of search at or just in advance of its position.

If the road on the approach to, or through the crossing is on a substandard curve or reverse curve, the appropriate curve, turn or reverse curve/turn sign with advisory speed sign, selected in accordance with Part 2 of the Manual, shall be placed in advance of the RX-3 assembly, with the W7-7 sign (see Clause 2.2.3) located further in advance.

**2.2.5 Railway crossing on side road assembly (RX-4)**

The RX-4 assembly shall be used in lieu of the RX-3 assembly to give advance warning of a crossing controlled by passive devices, i.e. GIVE WAY signs or STOP signs, and which -

- (a) is on an intersecting road; and
- (b) is too close to the intersection to provide the appropriate distance required for erection of the W7-7 sign and the RX-3 assembly on the side road, see Figure 4.10, Note 5 and Figure 4.11, Note 5.

**NOTES:**

- 1 The W7-7(R) sign is used on both the left and right hand versions of the RX-4 assembly.
- 2 In order not to downgrade the impact of the RX-4 assembly when used to warn of public railway crossings on side roads, it should not be used for farm access or other low vehicle volume property access crossings.

NOTE: This may be a low-resolution file intended for on-screen viewing only. This file cannot be printed. This file may be one part of a complete technical publication, and should not be read in isolation of the other parts of the publication. A full-resolution version of all parts of the publication can be obtained from the Department of Transport and Main Roads. www.tmr.qld.gov.au The Department of Transport and Main Roads takes no responsibility for any loss or damage resulting from the use of this low-resolution file.

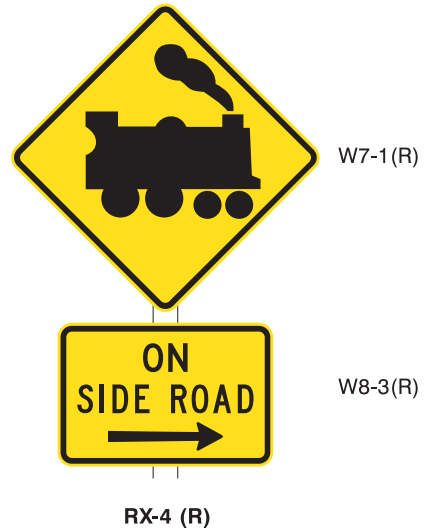
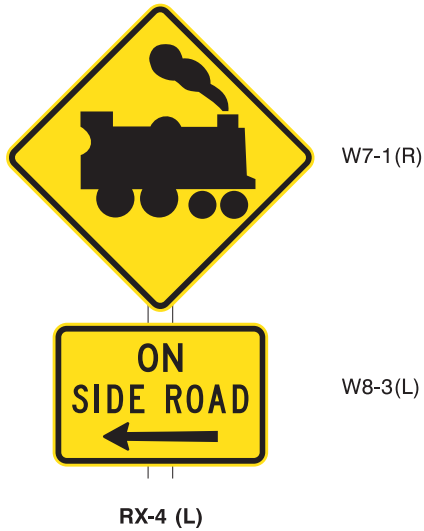

**2.2.6 Diagrammatic warning signs, on side road (W7-12, W7-13)**



Signs W7-12 and W7-13 shall be used at railway crossings on intersecting roads in conjunction with the RX-4 assembly where the crossings are controlled by either STOP or GIVE WAY signs. They are located as the first advance warning of the crossing, i.e. in advance of the RX-4 assemblies.

W7-12 is used where the crossing is on a side road which makes a T-junction with the through road. (Right-hand version of Sign W7-12 is obtained by inverting the sign.) This sign may also be used to indicate a crossing on the stem of a T-junction on which a driver is travelling, by rotating it through 90 degrees.

W7-13 is used where the crossing is on a side road which forms a crossroad with the through road. (Right-hand version of Sign W7-13 is obtained by inverting the sign.)

W7-17 (L or R) is used where the crossing is on the bar of a T-junction to warn traffic approaching along the stem.

**2.2.7 Stop sign ahead (W3-1)**



W3-1

The Stop Sign Ahead sign shall be used as the second or intermediate sign in advance of railway crossings controlled by STOP signs, except where this Part of the Manual specifically exempts crossings from the need for advance signs (see Clauses 4.2.2 and 4.4.2).

**2.3 ACTIVE CONTROL DEVICES**

**2.3.1 Railway crossing flashing signal assembly (RX-5)**



R6-24

W7-2-1

R6-9

**RX-5** (incorporating sign R6-24)

The RX-5 assembly shall be used at crossings that require flashing signal control. Its upper sign shall be either the R6-24 or the R6-25 sign.

NOTE: For new or refurbished RX-5 assemblies, the R6-25 sign is to be preferred. The sign should be the same on all assemblies facing any one approach to the crossing.

The railway crossing flashing signal shall consist of twin red circle aspects arranged horizontally and equipped to flash alternately.

The RX-5 assembly may be supplemented by boom barriers (see Clause 2.3.8).

Sign W7-2-1 or W7-2-2, (Number) ... TRACKS, shall be used at all multiple track crossings.

Overhead flashing signals should be used in conjunction with pedestal mounted assemblies in the following cases:

- (a) Where stopping sight distance to the pedestal mounted assembly is inadequate, e.g. because of vertical or horizontal alignment or other sight obstruction.
- (b) Where due to sight obstruction caused either by road geometry or frequent presence of high vehicles, the pedestal mounted assembly is not continuously visible as the road user approaches the crossing over the stopping sight distance.
- (c) Where there are more than two traffic lanes on the approach.

Regardless of the above, overhead signals should be omitted if there is a likelihood that they could appear confusing in relation to an adjacent signalized intersection.

A typical mast-arm arrangement is shown in Figure 2.1.



R6-25

W7-2-2

R6-9

**RX-5** (incorporating sign R6-25)

Overhead signals may be needed on side road approaches to a crossing if any of these requirements are met for traffic on these approaches.

Extended range signal lanterns may be used as recommended in AS/NZS 2144.

If intersection type traffic signals are to be incorporated into the RX-5 assembly, they shall be located immediately above the railway crossing flashing signals and below the R6-24(25) sign.

NOTE: A black supplementary target board of suitable size may be used to enhance the visibility of flashing signals.

NOTE: This may be a low-resolution file intended for on-screen viewing only. This file cannot be printed. This file may be one part of a complete technical publication, and should not be read in isolation of the other parts of the publication. A full-resolution version of all parts of the publication can be obtained from the Department of Transport and Main Roads. www.tmr.qld.gov.au The Department of Transport and Main Roads takes no responsibility for any loss or damage resulting from the use of this low-resolution file.

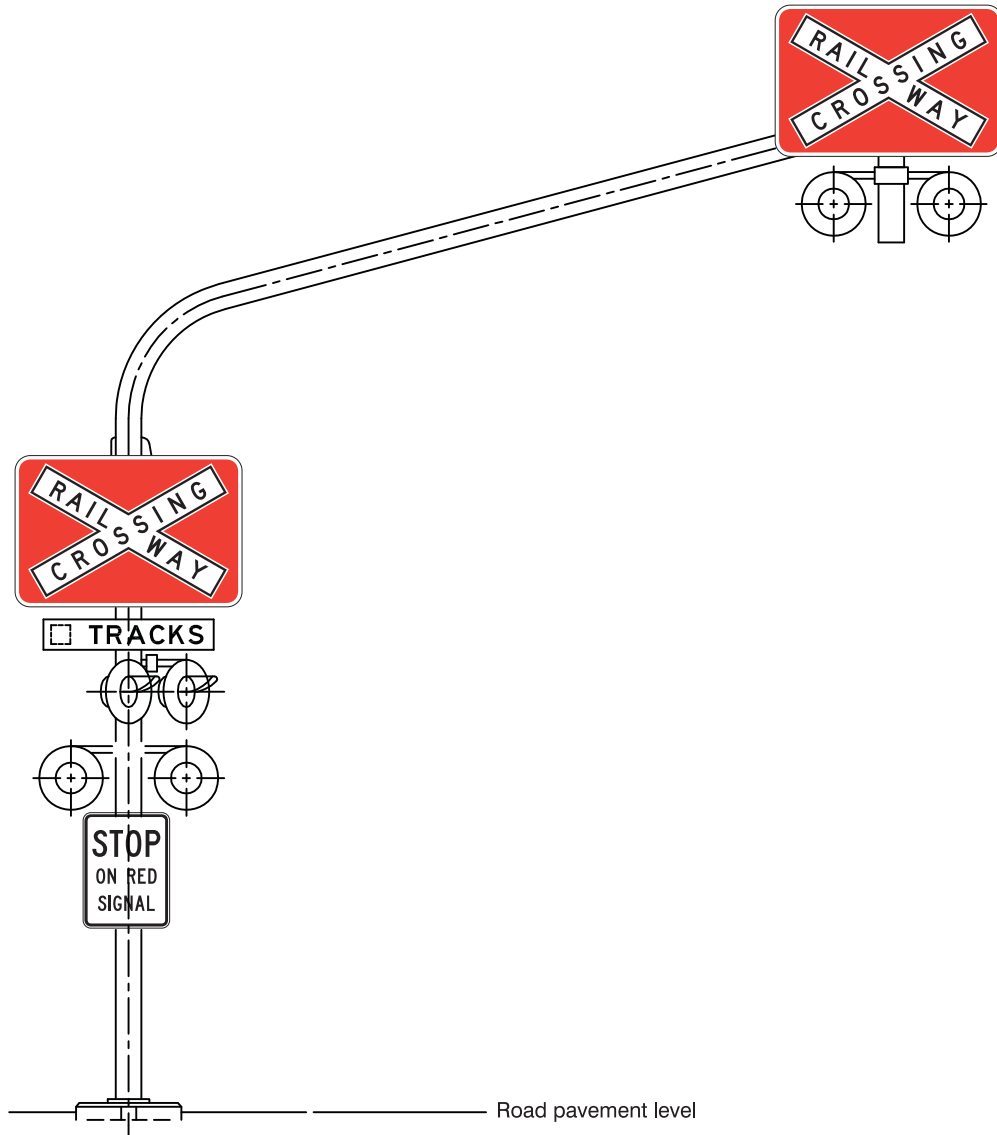

NOTE: The R6-24 signs may be needed in both positions in lieu of the R6-25 sign if the latter creates an excessive wind load on the mast arm.

DIMENSIONS IN MILLIMETRES

**FIGURE 2.1 OVERHEAD FLASHING SIGNAL ASSEMBLY**

**2.3.2 Railway crossing gate position sign assembly (RX-6)**



**RX-6** (incorporating sign R6-24)



**RX-6** (incorporating sign R6-25)

The RX-6 assembly comprises a STOP banner (R6-8) attached to the gate, and a RAILWAY CROSSING position sign assembly placed to the left of the gate, and shall be used at all crossings provided with gates. It is not used with boom barriers.

The upper sign of the position sign assembly shall be either the R6-24 or the R6-25 sign.

NOTE: For new or refurbished RX-6 assemblies, the R6-25 sign is to be preferred. The sign should be the same on all assemblies facing any one approach to the crossing.

On crossings with a single gate, the R6-8 sign shall be placed on the gate so that it is clearly visible to the oncoming traffic when the gate is closed.

When double gates are used, the R6-8 sign shall be placed on both gates to face approaching traffic.

Only the C or D size R6-8 sign shall be used on railway gates.

Sign W7-2-1 or W7-2-2, (Number) ... TRACKS, shall be used at all multiple track crossings.

**2.3.3 Railway crossing flashing signals ahead sign (W7-4)**



W7-4

The W7-4 sign shall be used to give advance warning of a crossing controlled by flashing signals (see Clause 2.3.1) including those where boom barriers are installed in conjunction with the signals.

Where the crossing is on the side road, an RX-7 assembly shall be used instead of this sign (see Clause 2.3.5).

This sign may need to be repeated on the right-hand side of the carriageway for added emphasis, e.g. on high volume roads. It may also need to be repeated at a long distance (e.g. 500 m) in advance of the crossing, in which case the Distance plate, W8-5, shall be mounted below the sign.

**2.3.4 Railway gate (W7-15)**



W7-15

The RAILWAY GATE sign shall be used to give advance warning of a crossing controlled by gates. It is positioned on the left side of the carriageway at the appropriate distance from the crossing.

Where a crossing is on a side road, an RX-8 assembly shall be used instead of this sign (see Clause 2.3.6).

This sign may need to be repeated on the right-hand side of the carriageway on high volume roads or other road types for added emphasis. It may also need to be repeated at a long distance (e.g. 500 m) in advance of the crossing, in which case the Distance plate, W8-5, shall be mounted below the sign.

**2.3.5 Railway crossing flashing signals ahead on side road assembly (RX-7)**



W7-4



W8-3(L)

RX-7

The RX-7 assembly shall be used to give advance warning on a through road of a crossing which is controlled by flashing signals when the crossing -

- (a) is on a side road; and
- (b) is too close to the intersection to provide the appropriate distance required for erection of the W7-4 sign on the side road (see Figure 4.12, Note 4).

The assembly shall be positioned on the through road on the left side of each approach to the intersection.

For a side road on the right the W8-3(R) sign shall be used.

### 2.3.6 Railway crossing gate on side road assembly (RX-8)

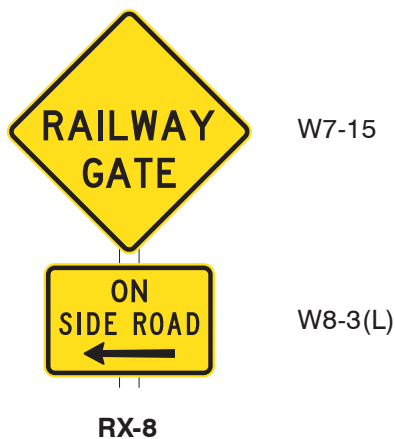

The RX-8 assembly shall be used to give advance warning on a through road of a crossing which is controlled by gates when the crossing -

- (a) is on a side road; and
- (b) is too close to the intersection to provide the appropriate distance required for erection of the W7-15 sign on the side road (see Figure 4.13, Note 4).

The assembly shall be positioned on the through road on the left side of each approach to the intersection.

For a side road on the right the W8-3(R) sign shall be used.

### 2.3.7 Active advance warning assembly (RX-11)

Active advance warning assemblies may be provided in advance of a crossing to supplement railway crossing flashing signals by providing visual advance warning to road users that there is a requirement to stop at a railway crossing due to the impending activation of the railway crossing flashing signals at the crossing. The lights in the advance warning assembly begin flashing a predetermined number of seconds before the crossing signals activate.

NOTES:

- 1 Guides for use of this device together with recommended methods of locating the assembly and setting its operational timing are given in Appendix E
- 2 These assemblies are particularly effective in improving safety on high speed road approaches used by heavy vehicles or where the required visibility to the flashing signals at the crossing cannot be attained by other measures.

Where used, the RX-11 assembly shall comprise the following elements:

- (a) Railway Crossing Flashing Signals Ahead (W7-4) sign.
- (b) PREPARE TO STOP panel. (A suitable design for this panel is shown as Sign No. W8-27 in AS 1743.)
- (c) Two alternately flashing yellow lights each conforming to the performance requirements for a yellow traffic signal lantern in AS/NZS 2144. The flash cycle shall be the same as that used for the railway crossing flashing signals.

Items (a) and (b) shall be displayed on a yellow rectangular signboard. Typical format is shown in Figure 2.2.



FIGURE 2.2 EXAMPLE OF AN RX-11 ACTIVE ADVANCE WARNING ASSEMBLY

### 2.3.8 Boom barrier

#### 2.3.8.1 General description and placement

Boom barriers shall comprise as a minimum, a boom extending from the left side of the roadway;

- (a) to the right hand kerb or edge of a one-way roadway;
- (b) to the edge of a median island; or
- (c) in the case of a two-way roadway, to the dividing line or centre of the roadway if no line is marked.

The boom in its lowered state shall be placed at right angles to the road centre line.

#### 2.3.8.2 Design

The boom shall be a minimum width of 100 mm in the vertical plane and may taper from a maximum width of 150 mm at its support end. It shall have 100 mm wide longitudinal strips of retroreflective material on each face, each comprising alternating red and white bands each 450 +50 mm in length with ends at 45 degrees to the vertical. The outer band shall be white. The boom shall be equipped with a minimum of three red lamps visible from both directions. The outer lamp shall be steady and the inner two flashing alternately. A typical assembly is shown in Figure 2.3.

NOTES:

- 1 Pending preparation of an Australian Standard for boom barriers they will be required to conform to the requirements of the Australasian Railway Association.
- 2 The height of the boom above road level in its lowered position is subject to railway organization requirements. It will generally be between 850 mm and 1000 mm.

#### 2.3.8.3 Preventing misuse

Where on an undivided road there is a history of drivers skirting the barrier in its lowered position, the following steps are recommended to inhibit the practice:

- (a) Provision of a median island on the relevant approaches to the crossing.
- (b) Addition of frangible bollards or fencing in the median.

If a median island extends partly onto the crossing it shall be fully mountable to permit any trapped vehicle to escape across it and shall not infringe the railway minimum structure outline.

### 2.3.9 Traffic signals at light rail crossings

Intersection type traffic signals may be used in lieu of RX-5 flashing signal assemblies to provide active control of light rail crossings in urban areas. Where used, the road approach shall be treated as though it were an approach to an intersection, i.e. with signs and markings provided in accordance with Part 2 and signals in accordance with Part 14 of the Manual. Neither boom barriers nor signs of the type R6-24, R6-25 or R6-26 shall be used.

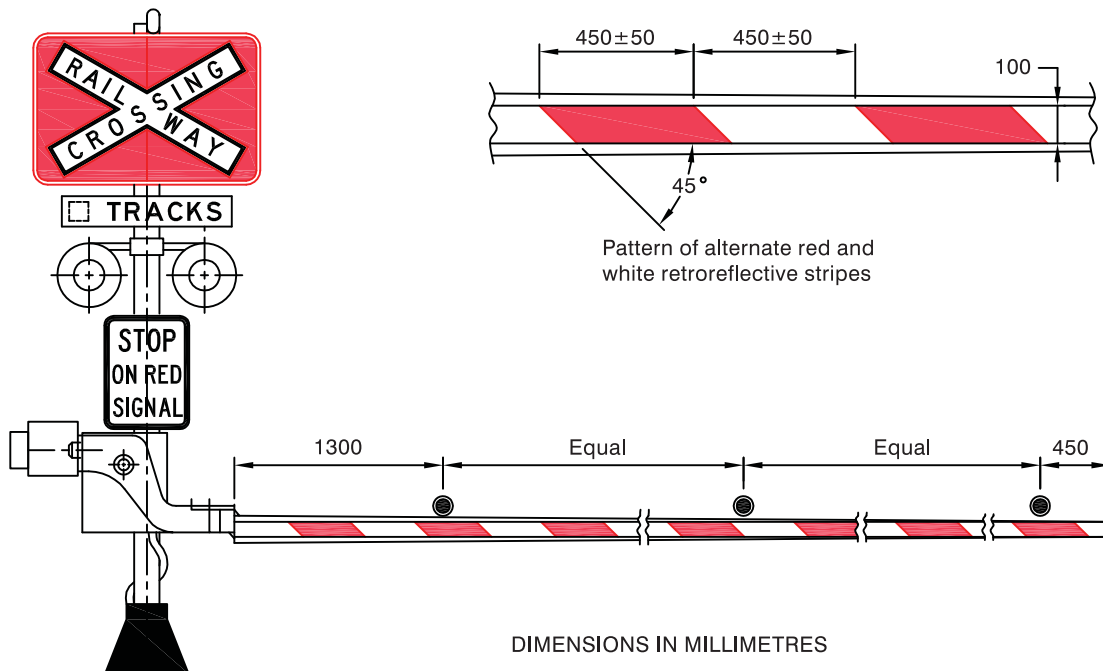

FIGURE 2.3 TYPICAL RAILWAY CROSSING FLASHING SIGNAL AND BOOM BARRIER ASSEMBLY

## 2.4 DEVICES USED AT EITHER ACTIVE OR PASSIVE CONTROL CROSSINGS

### 2.4.1 (Distance) m (W8-5)



The Distance plate shall be used in conjunction with advance warning signs where long distance (e.g. 500 m) advance warning is required.

### 2.4.2 Railway crossing width marker assembly (RX-9)

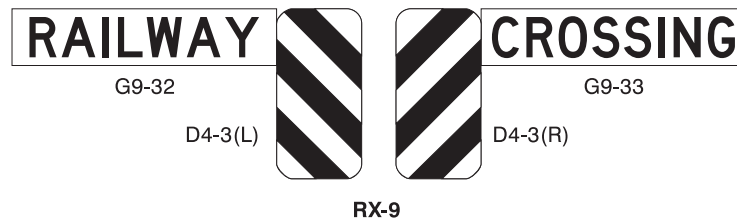

The RX-9 assembly should be used as illustrated in Figure 2.4 where the conspicuity of the crossing needs to be enhanced, typically on high speed rural road approaches. It is located immediately in advance of the RX-1, RX-2 or RX-5 assemblies (see Clauses 2.2.1, 2.2.2 and 2.3.1) and on each side of the railway crossing.

Alternatively, if the road approach to the railway crossing is on a sharply curved alignment, it may be desirable to erect both the RAILWAY and CROSSING signs together on one side of the roadway on the outside of the curve at the end of the approach straight with Chevron Alignment markers (D4-6) (Clause 2.4.3) mounted above and beside them. The width markers (D4-3) are then mounted on either side of the road at the crossing.

In either of the above installations, care needs to be taken that the signs or assemblies do not obstruct sight lines to trains for road users, including pedestrians, at passive control crossings, or to other road traffic at any crossing.

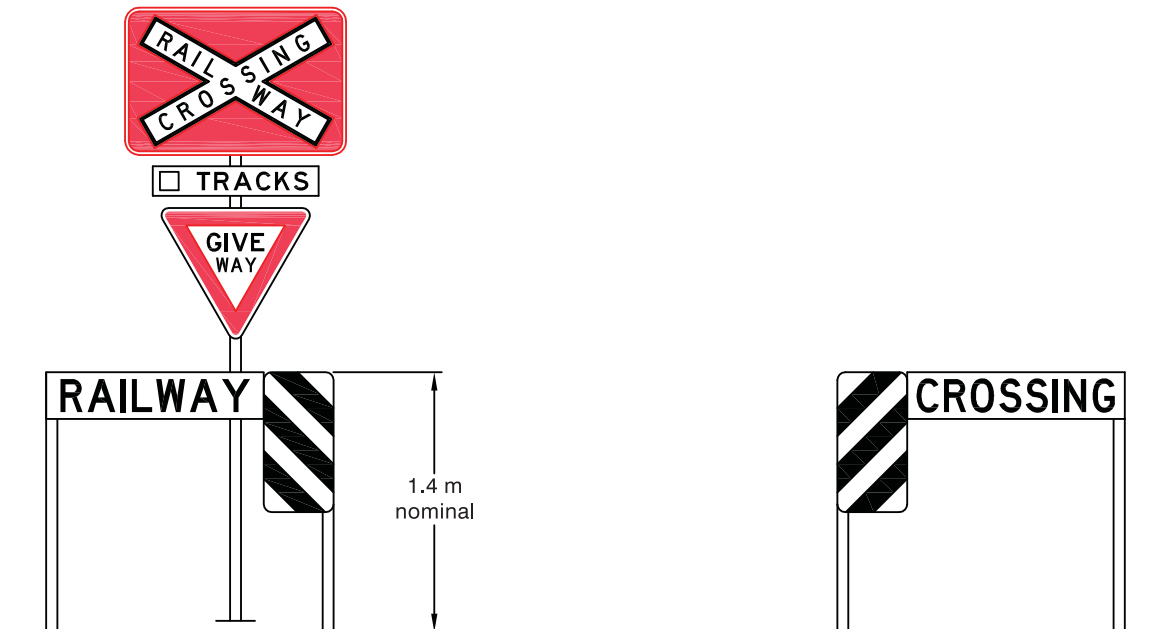

FIGURE 2.4 ARRANGEMENT OF RAILWAY CROSSING SIGNS WITH WIDTH MARKERS

NOTE: This may be a low-resolution file intended for on-screen viewing only. This file cannot be printed. This file may be one part of a complete technical publication, and should not be read in isolation of the other parts of the publication. A full-resolution version of all parts of the publication can be obtained from the Department of Transport and Main Roads. www.tmr.qld.gov.au The Department of Transport and Main Roads takes no responsibility for any loss or damage resulting from the use of this low-resolution file.

**2.4.3 Chevron alignment marker (D4-6)**



D4-6

Chevron Alignment markers (D4-6) are used where the road approach to the railway crossing is on a sharply curved alignment. The markers should be positioned around the back of the curve as recommended in Part 2 of the Manual. Where close spacing of the markers is required, they may be placed both beside and above the G9-32/G9-33 assembly so that the desired regular spacing is achieved.

**2.4.4 KEEP TRACKS CLEAR (G9-67-1, G9-67-2)**



G9-67-1



G9-67-2

The G9-67-1 sign shall be used where traffic is likely to queue inadvertently across a crossing due to a downstream traffic delay. Other measures shall be used as appropriate to reduce the risk of a train/road user collision from this cause, see Clauses 5.2 and 5.3.

The G9-67-2 sign shall be used where box markings (see Clause 3.6) have been placed on the crossing. The word TRACKS may be omitted from the G9-67-2 sign.

**2.4.5 TRAMWAY CROSSING position (R6-26)**

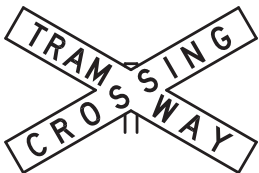

R6-26

This sign is not approved for use in Queensland.

**2.4.6 RAILWAY CROSSING NOT IN USE (G9-74)**



G9-74

This sign is not approved for use in Queensland.

## SECTION 3. PAVEMENT MARKINGS

### 3.1 GENERAL

A summary of requirements for pavement markings on sealed approaches to crossings is as follows:

- (a) RAIL X marking (see Clause 3.2) shall be used on all high-speed approaches of adequate seal width except at crossings on side roads where the distance to the crossing is less than specified in Clause 3.2.
- (b) Stop or give-way line (see Clauses 3.3 and 3.4) shall be used on all approaches in all cases.
- (c) No-overtaking lines (see Clause 3.5) comprising either barrier or single continuous dividing lines shall be used on all undivided road approaches where the sealed width is 5.5 m or greater.

### 3.2 RAILWAY CROSSING PAVEMENT MARKING (RAIL X)

The pavement marking RAIL X shall be as shown in Figure 3.1. Except for crossings on side roads (see below) and cane railways (refer Clause 7.2.4), the marking shall be provided on all roads where the seal width is 3.0 m or greater and the speed limit is greater than 80 km/h. The marking is to read sequentially. On multilane roads a separate marking shall be placed in each approach lane.

It should also be considered for low speed situations i.e. speed limit 80 km/h or less, where additional advance warning is considered desirable. In such cases, it may be reduced in letter height to that shown in Figure 3.1 and read 'down', i.e. the X preceding the RAIL.

On through road approaches to a crossing the marking shall generally be placed 15 to 20 m beyond the first advance sign, but positioned if necessary to provide adequate visual impact giving at least 50 m clear viewing distance to the near edge of the marking.

On approaches to crossings on side roads where the distance from the edge of the through traffic lane to the stop or give-way line is 60 m or more and the conditions above are met, the marking shall be placed 15 to 20 m beyond the edge of the through traffic lane. The marking may not be required where the side road distance as specified above is less than 60 m.

### 3.3 STOP LINE

A stop line is an unbroken line marked across traffic lanes. It shall be a minimum of 300 mm wide and 600 mm minimum where the speed limit is greater than 80 km/h. At all railway crossings on sealed roads controlled by RX-2, RX-5 and RX-6 (STOP sign, flashing signals and gate control) assemblies, a stop line shall be provided on each approach to indicate the location at which vehicles must stop as and when required by law. It shall be placed at right angles to the road centre-line as follows:

- (a) *At STOP signs* - 3.5 m minimum back from the nearest rail at its closest point.
- (b) *At flashing signal control* - 3 m minimum back from the signal pedestal or boom barrier in its lowered position.
- (c) *At gates* - 3 m minimum back from the gates when closed to road traffic.

In the absence of a dividing line or median, the stop line shall extend only to the centre of the seal.

### 3.4 GIVE-WAY LINE

A give-way line is a broken line consisting of line segments 600 mm long separated by 600 mm gaps. It shall be a minimum of 300 mm wide or 600 mm minimum where the speed limit is greater than 80 km/h. At all railway crossings on sealed roads controlled by RX-1 (GIVE WAY sign control) assemblies, a give-way line shall be placed on each approach to indicate the safe position for vehicles to stop, if necessary, to avoid conflict with a train. It shall be placed at right angles to the road centre-line 3.5 m back from the nearest rail at its closest point.

In the absence of a dividing line, or median, the give-way line shall extend only to the centre of the seal.

### 3.5 NO-OVERTAKING LINES

On undivided sealed two-way roads where the sealed width is 5.5 m or greater, no-overtaking lines shall be provided on the approaches to and, where necessary, across railway crossings in accordance with Clause 3.1. The no-overtaking line on each approach should extend from the crossing to the initial warning sign or to the through road where the crossing is on a side road and requires treatment in

accordance with Clause 2.2.5, 2.3.5 or 2.3.6. The no-overtaking line shall comprise one of the following:

- (a) **Barrier line** - A barrier line is a dividing line which prohibits overtaking movements or movements across the line to enter or leave the road in one or both directions, as described in the following:
  - (i) **Barrier lines (one-way)** A one-way barrier line consists of an unbroken line used in combination with a broken line. Crossing and overtaking movements across the lines are permitted from the broken line side but not from the unbroken line side. This line should be used if it is desired to permit overtaking across the separation line on the departure side of the crossing.
  - (ii) **Barrier lines (two-way)** A two-way barrier line consists of two unbroken lines. Movements across the lines, or to the right of the lines, for the purpose of crossing or overtaking in either direction are prohibited.
- (b) **Single continuous dividing line** This line should be used only where it is desired to permit traffic to cross the line to enter or leave the road.

NOTE: This may be a low-resolution file intended for on-screen viewing only. This file cannot be printed. This file may be one part of a complete technical publication, and should not be read in isolation of the other parts of the publication. A full-resolution version of all parts of the publication can be obtained from the Department of Transport and Main Roads. [www.tmr.qld.gov.au](http://www.tmr.qld.gov.au) The Department of Transport and Main Roads takes no responsibility for any loss or damage resulting from the use of this low-resolution file.

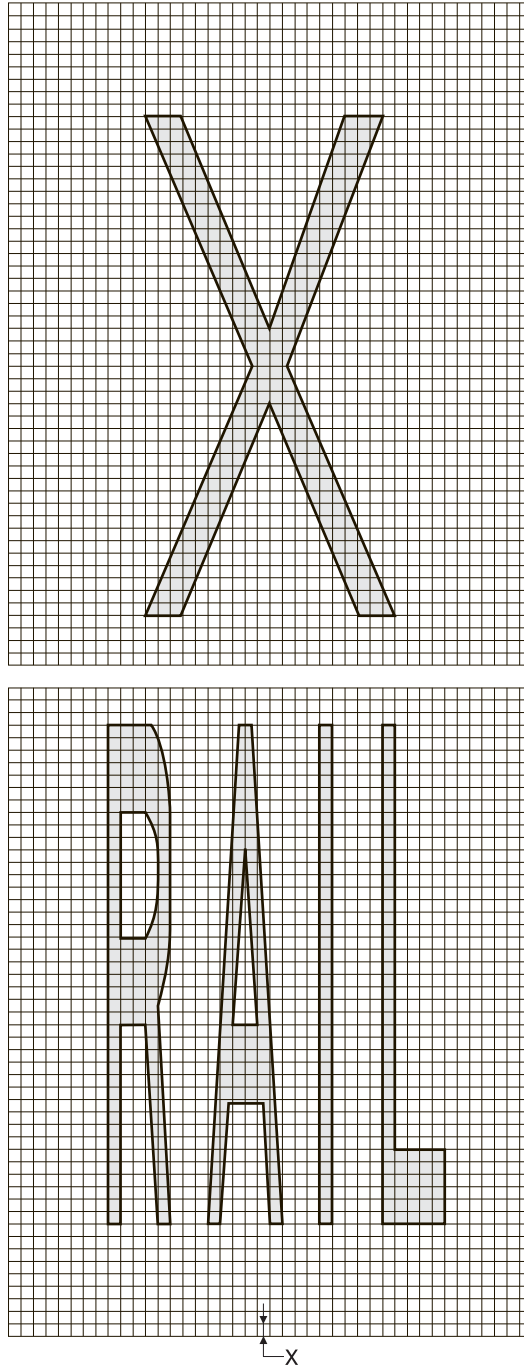

NOTES:

1. The grid width is 100 mm minimum.  
 The grid height  $X = \frac{\text{Height of letter or symbol required (mm)}}{40}$
2. Minimum dimensions for the length and spacing of the markings are -
 

Standard case:	X - 6.0 m	Low speed case:	X - 3.0 m
	RAIL - 5.0 m		RAIL - 2.5 m
	Spacing - 7.5 m		Spacing - 2.5 m
	Message to read sequentially		Message to read down
3. Marking to commence with base of the first letter or word located 15 to 20 m beyond the first advance sign, e.g. the W7-4 or W7-7.

**FIGURE 3.1 'RAIL X' PAVEMENT MARKING**

### 3.6 BOX MARKINGS

Box markings shall only be used to discourage traffic queuing on a crossing where the conditions described in Clause 5.3 apply. Where used they shall comprise a yellow diamond hatch marking as set out in Figure 3.2. The lines forming the diamond pattern shall be 150 mm wide.

Where queuing is a problem in one direction only, the box marking shall be placed on that side of the pavement only as shown in Figure 3.2. If queuing is a problem in both directions of travel the marking shall be placed on both sides.

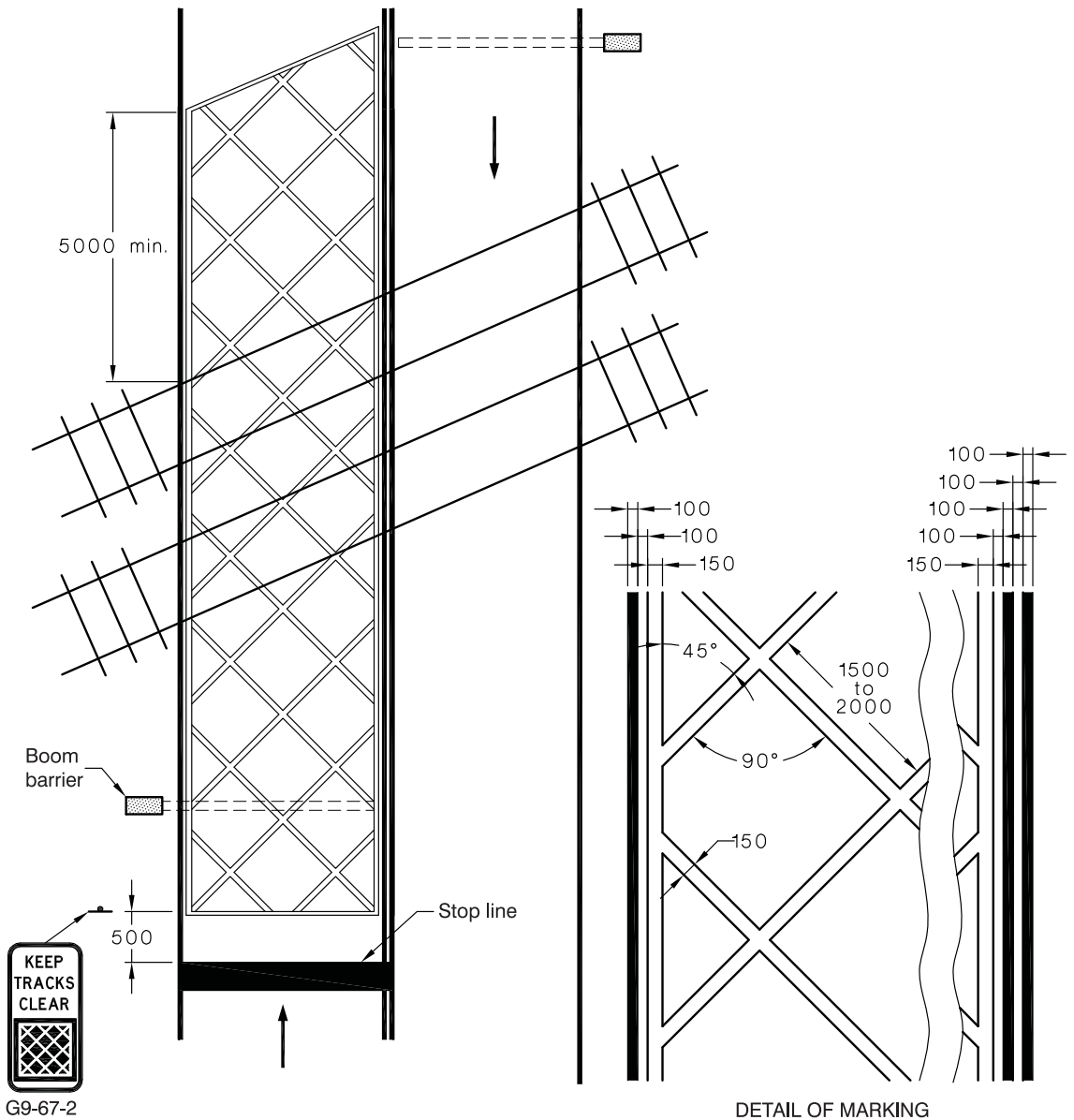

NOTE: The KEEP TRACKS CLEAR sign is to be located so that it does not obscure the crossing signals or associated signs. A mounting height of less than 1 m may be required.

DIMENSIONS IN MILLIMETRES

FIGURE 3.2 BOX MARKING

## SECTION 4. APPLICATION OF SIGNS AND MARKINGS TO RAILWAY CROSSINGS

### 4.1 GENERAL

The regulatory control and warning of road users approaching a railway crossing may be by means of active or passive control (see Clauses 1.4.1 and 1.4.4). The latter relies mainly on fixed message signs and pavement markings, whereas the former includes train actuated signalling devices, movable barriers and gates.

The type of control used at a railway crossing will depend upon the requirements of individual locations taking into account safety, traffic volume, geometry and other considerations. The application of these controls is described and illustrated as follows:

- (a) *Passive control* Clause 4.2.
- (b) *Active control* Clause 4.3.
- (c) *Modified treatments* Clause 4.4.
- (d) *Temporary and emergency control* Clause 4.6.

### 4.2 PASSIVE CONTROL TREATMENTS

#### 4.2.1 Control by give-way and stop signs

The application of passive control treatments to railway crossings by use of give-way or stop sign control shall be determined by the sight distance available to a road vehicle driver to an approaching train.

The need for give-way or stop sign control shall be assessed and the control implemented as follows:

NOTE: The step from give-way sign to stop sign treatment is not a hierarchical step. It is a function of which treatment matches the sight distance available.

- (a) *Give way sign control* The sight distance shall be sufficient for the road vehicle driver approaching the crossing at the 85th percentile speed to see an approaching train in time to stop if necessary before reaching the crossing. The sight distance requirement of Item(b) shall also be met.

Except as provided in Clauses 4.2.2 and 4.4.2, where give way sign control is required it shall be by use of GIVE WAY signs incorporated into RX-1 assemblies together with advance signs and other devices as shown in Figure 4.4. Modifications to this treatment for a crossing on a side road are given in Clause 4.4.1.

- (b) *Stop sign control* The sight distance shall be sufficient for the road vehicle driver stopped at the railway crossing stop line to be able to start off and clear the crossing before the arrival of a previously unseen train. If this sight distance is not available, see Clause 4.2.3.

Except as provided in Clause 4.4.2, where stop sign control is required it shall be by use of STOP signs incorporated into RX-2 assemblies together with advance signs and other devices as shown in Figures 4.5 and 4.6 which shall include the stop sign ahead (W3-1) sign. Modifications to this treatment for a crossing on a side road are given in Clause 4.4.1. Stop sign treatments shall not be used where sight distance is adequate for give-way sign treatment.

NOTE: This Part of the Manual does not preclude use of stop sign control on one approach to a passive control crossing and give way control on the other if circumstances (such as sight distance) differ sufficiently from one side to the other.

The relationship between the sight distance triangles required for the give-way sign case and the stop sign case is illustrated in Figure 4.1. Triangle A represents the sight distance needed for a road vehicle approaching and potentially crossing at speed, i.e. give-way sign control can be used. Triangle B represents the sight distance required for safe start up and clearance from the crossing for a stopped vehicle, i.e. the triangle needed for both stop and give-way sign control.

Calculation of these sight distances shall be as specified in Appendix D.

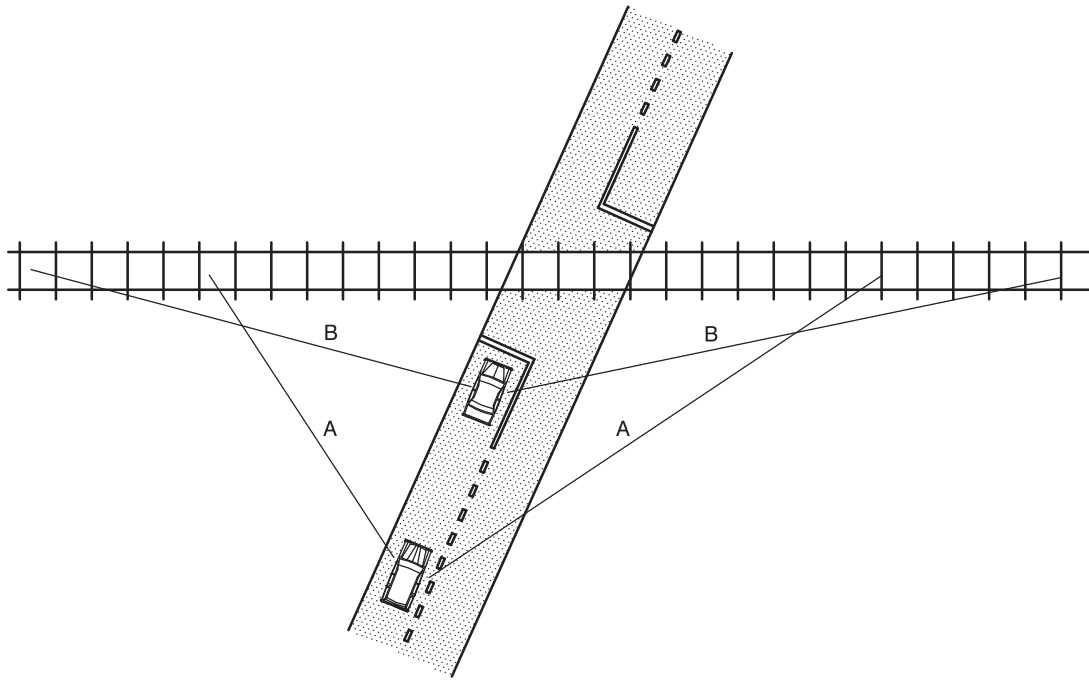

**FIGURE 4.1 SIGHT TRIANGLES FOR GIVE-WAY AND STOP SIGN CONTROL**

**4.2.2 Minimum treatment crossings**

The absolute minimum treatment required at any railway crossing where there is provision for motor vehicles to cross the railway shall be the RX-1 assembly comprising the railway crossing position sign R6-24 or R6-25, and the GIVE WAY sign, see Figure 4.3.

NOTE: This excludes crossings covered in Clause 1.2.

The application shall be limited to the cases specified in Table 4.1 and shall apply to single tracks only.

**TABLE 4.1 LIMITS ON USE OF MINIMUM TREATMENT CROSSINGS**

Case	85th percentile approach speed: road traffic km/h	Visibility distance to sign for road users m	Application
1	60 max.	90 min.	Applicable where traffic volume is less than 200 vpd
2	40 max.	40 min.	Applicable to any road
3	any speed	20 min.	Applicable only to a crossing on a side road not more than 40 m from the main road

The treatment shall be restricted to situations where give-way sign control can be used, see Clause 4.2.1 (a). At crossings meeting the Case 2 requirements of Table 4.1, the RX-1 assembly reduced in sign size to not less than 50% may be used.

Advance warning signs may be omitted.

At all passive control crossings not meeting the requirements of this clause the full treatments specified in Clause 4.2.1 shall be used.

### 4.2.3 Inadequate sight distance for passive control

Where the sight distance available to a road vehicle driver is less than that required for stop sign control, regardless of whether it meets the requirement for give-way sign control, passive control shall not be used at the crossing. If the crossing is to remain open, alternative measures shall be applied. These may include restoration of sight distance by sight benching in cuttings, clearing, geometric alteration of the crossing or change to active control.

## 4.3 ACTIVE CONTROL TREATMENTS

### 4.3.1 Flashing signals

Figures 4.7 and 4.8 illustrate typical applications of flashing signals (other than modified treatments, see Clause 4.4) and the additional warning signs and devices required to be used with them. Boom barriers may be added for increased protection, see Clause 2.3.8.

Flashing signals shall commence activation a minimum of 20 s prior to the arrival of a train at a single track crossing. Greater periods may be required at multiple track crossings.

### 4.3.2 Railway crossing gates

Figure 4.9 illustrates the signs and assemblies used at railway crossings where gates (other than boom barriers) are used.

## 4.4 MODIFIED TREATMENTS

### 4.4.1 Railway crossing on side road

Treatments at railway crossings on a side road other than as provided in Clause 4.2.2 or 4.4.2 shall be as illustrated in the following figures:

- (a) Give-way sign, Figure 4.10.
- (b) Stop sign, Figure 4.11.
- (c) Flashing signal control, Figure 4.12.
- (d) Gate control, Figure 4.13.

At crossings which are close to the main road, generally 25 m or less, steps should be taken to reduce the vehicle turning speed as much as possible, e.g. by geometric layout modification, so that drivers turning into the side road will have more time to appreciate and react to the presence of the crossing. A second position assembly, RX-1, RX-2, RX-5 or RX-6 (excluding the R6-8 sign) shall be installed on the right-hand side of the road if necessary to ensure that one or other is clearly visible to traffic turning from either direction.

### 4.4.2 Crossings in low speed urban environments

Advance warning signs may be omitted in built-up areas from active control crossings where 85th percentile road approach speeds are 60 km/h or less or from passive control crossings where 85th percentile road approach speeds are 40 km/h or less, provided that adequate visibility and prominence of position signs and signals are assured.

Enhancement of position signs may be required by means such as the following to compensate for the absence of advance signs:

- (a) Duplication on right side of roadway.
- (b) Increase in sign size.
- (c) Overhead mounting.
- (d) Addition of the RX-9 width marker assemblies.

### 4.4.3 Ports and terminals

In port areas, freight terminals and grain handling facilities, if it is not practicable to apply the treatments given in this Part of the Manual, alternatives need to be developed on a risk assessment basis.

Alternative strategies may include:

- (a) Control of road and train speeds.

(b) Implementing special operating instructions.

### 4.5 STOP SIGNS AT COMBINED ROAD/RAIL CROSSINGS

A combined road/rail crossing is where a road crosses another road and a railway line. If stop control is justified as a result of inadequate sight distance, the following combination of signs is required (refer Figure 4.2). This particular setout is required to convey the message that motorists approaching the intersection shall give way to both trains and motor vehicles crossing the intersection.

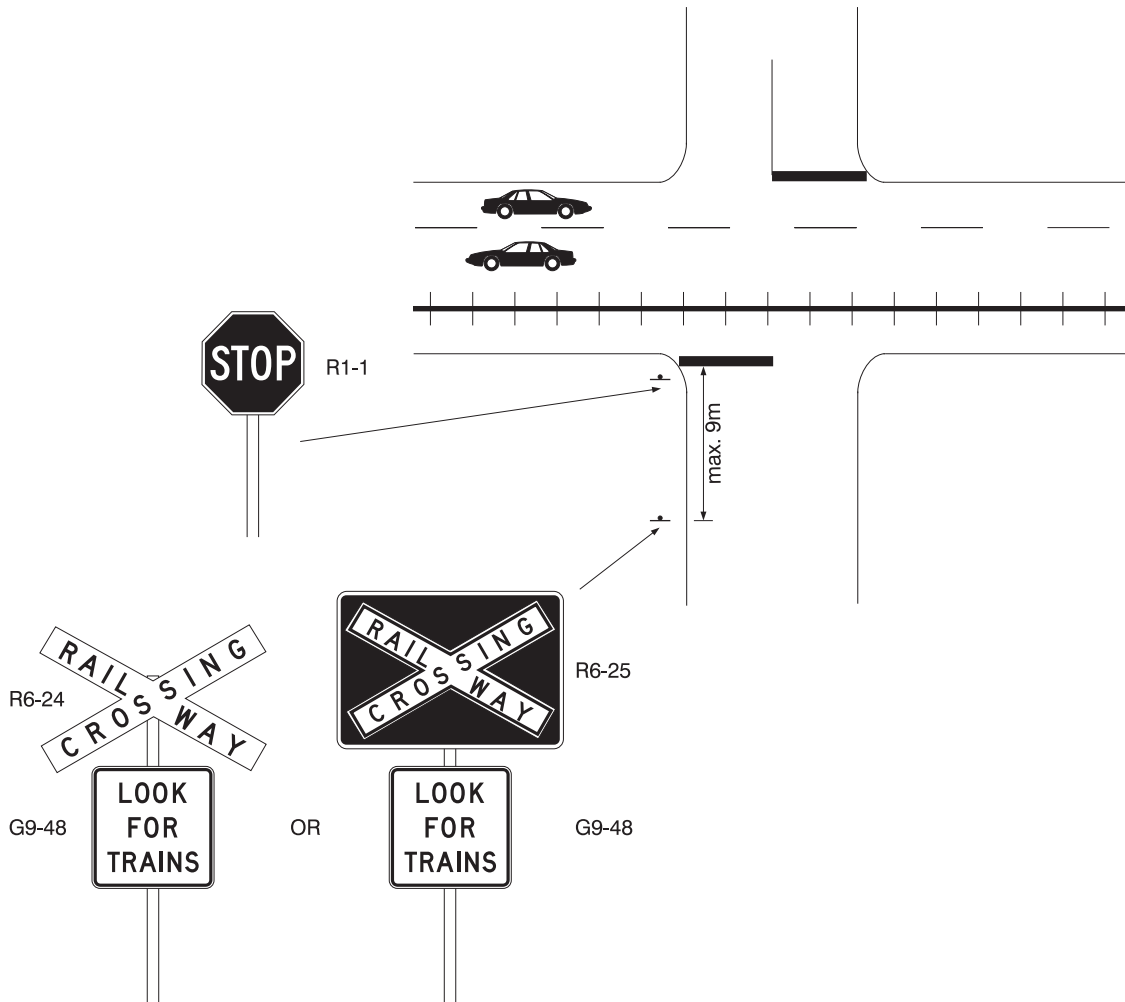

**FIGURE 4.2 STOP SIGNS AT COMBINED ROAD/RAIL CROSSINGS**

The stop sign shall be no further than 9 metres from the stop line. In some cases it may be appropriate to place the stop sign adjacent to the railway crossing sign, with the stop sign closest to the kerb.

### 4.6 TEMPORARY AND EMERGENCY CONTROL

In the event of an emergency closure of a crossing, any temporary means at hand such as flags or STOP bats that have been used initially, shall be replaced as quickly as possible with a short-term roadworks site arrangement in accordance with Part 3 of the Manual. Scheduled short or long-term roadworks at crossings shall be carried out in accordance with Part 3 of the Manual.

### 4.7 CLOSURE OF A RAILWAY LINE

At crossings on railway lines which have been closed, all signs and pavement markings referring to the fact that it was formerly a railway crossing shall be removed.

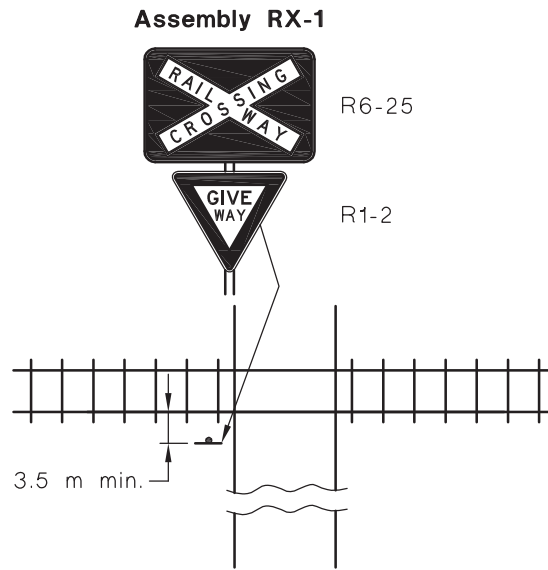

**NOTES:**

- 1 The railway crossing position sign may be either the R6-24 or the R6-25 sign.
- 2 Conditions under which this treatment may be used are specified in Clause 4.2.2.
- 3 If the crossing is on a sealed pavement, markings as specified in Clause 3.1 shall be provided.

**FIGURE 4.3 MINIMUM TREATMENT CROSSING**



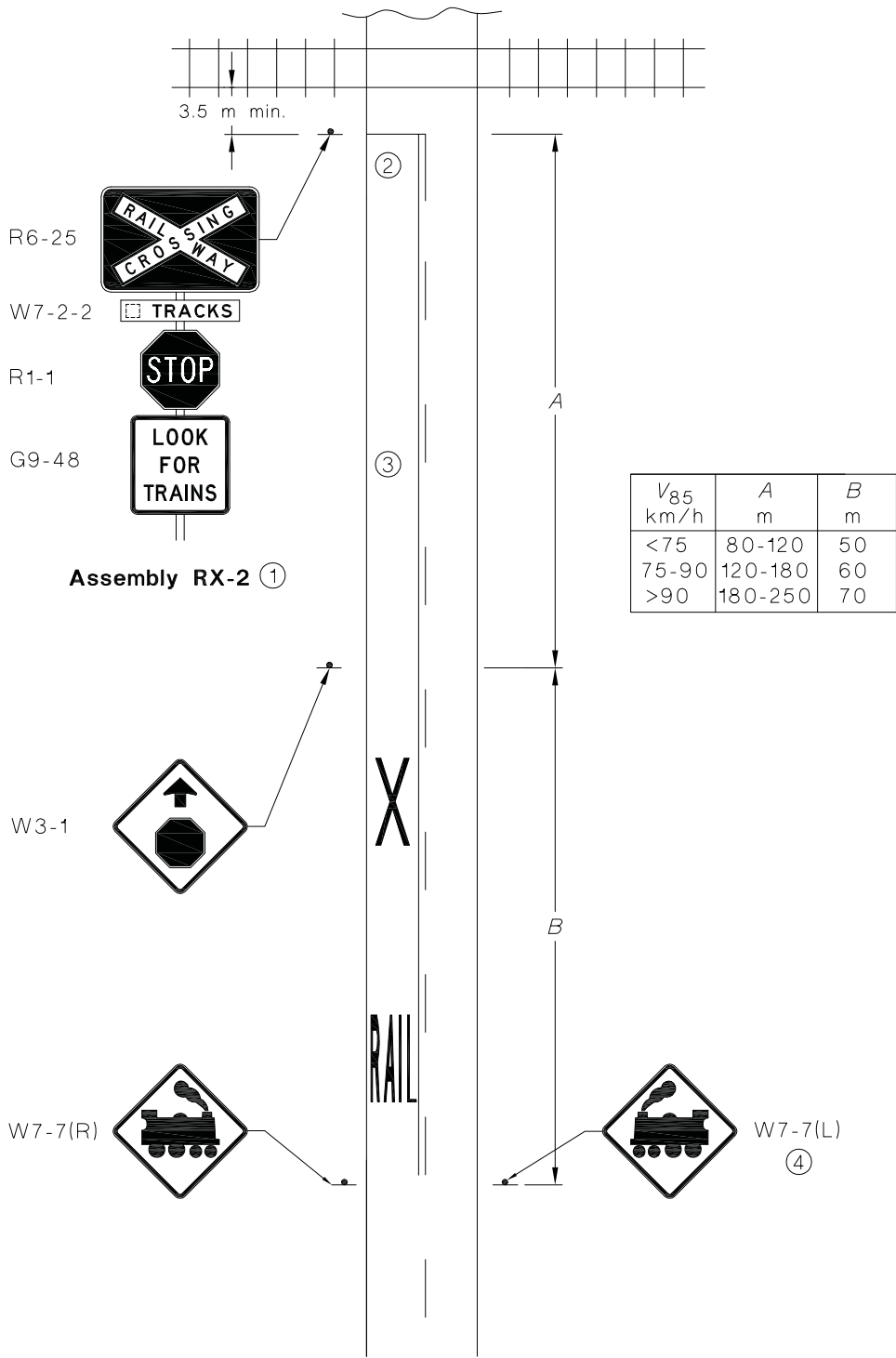

NOTES:

- 1 If more than one track, the TRACKS sign, W7-2-1 or W7-2-2, is added to the assembly. The RAILWAY CROSSING position sign may be either the R6-24 or R6-25 sign.
- 2 Stop lines (see Clause 3.3) are required on sealed roads at crossings controlled by STOP signs.
- 3 The barrier line (see Clause 3.5) should extend at least to the advance sign, W7-7.
- 4 The right-hand side sign, W7-7(L), is for optional use on busy roads (see Clause 2.2.3).

**FIGURE 4.5 RAILWAY CROSSING WITH STRAIGHT APPROACH CONTROLLED BY STOP SIGNS (PASSIVE CONTROL)**

NOTE: This may be a low-resolution file intended for on-screen viewing only. This file cannot be printed. This file may be one part of a complete technical publication, and should not be read in isolation of the other parts of the publication. A full-resolution version of all parts of the publication can be obtained from the Department of Transport and Main Roads. www.tmr.qld.gov.au The Department of Transport and Main Roads takes no responsibility for any loss or damage resulting from the use of this low-resolution file.

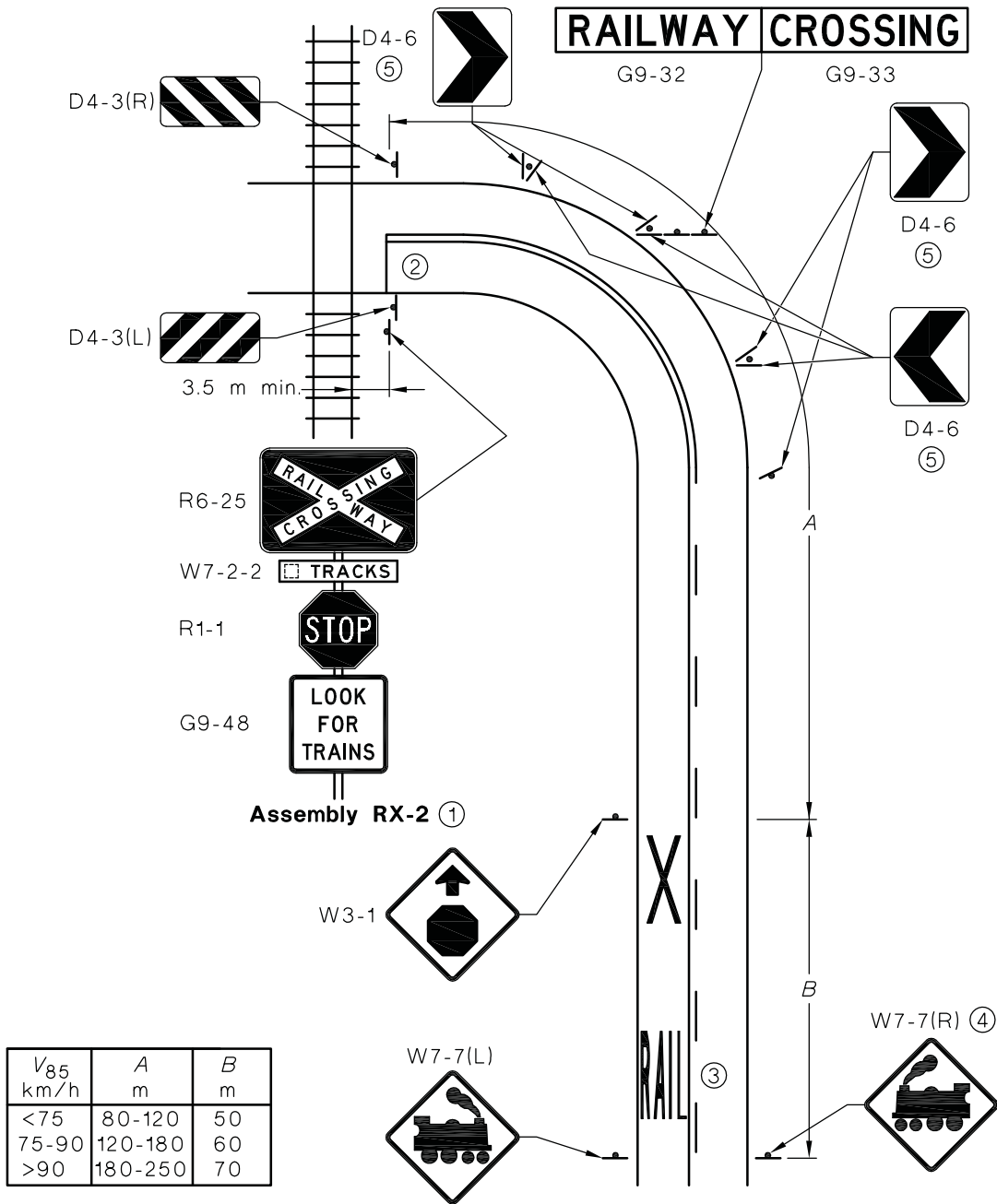

NOTES:

- 1 If more than one track, the TRACKS sign, W7-2-1 or W7-2-2, is added to the assembly. The RAILWAY CROSSING position sign may be either the R6-24 or R6-25 sign.
- 2 Stop lines (see Clause 3.3) are required on sealed roads.
- 3 The barrier line (see Clause 3.5) should extend at least to the advance sign, W7-7.
- 4 The right-hand side sign, W7-7(L), is for optional use on busy roads (see Clause 2.2.3).
- 5 Chevron alignment markers, D4-6, are used where required to reinforce the delineation of a sharp curve (see Clause 2.4.3).

**FIGURE 4.6 RAILWAY CROSSING CONTROLLED BY STOP SIGNS PRECEDED BY A CURVE (PASSIVE CONTROL)**

NOTE: This may be a low-resolution file intended for on-screen viewing only. This file cannot be printed. This file may be one part of a complete technical publication, and should not be read in isolation of the other parts of the publication. A full-resolution version of all parts of the publication can be obtained from the Department of Transport and Main Roads. [www.tmr.qld.gov.au](http://www.tmr.qld.gov.au) The Department of Transport and Main Roads takes no responsibility for any loss or damage resulting from the use of this low-resolution file.

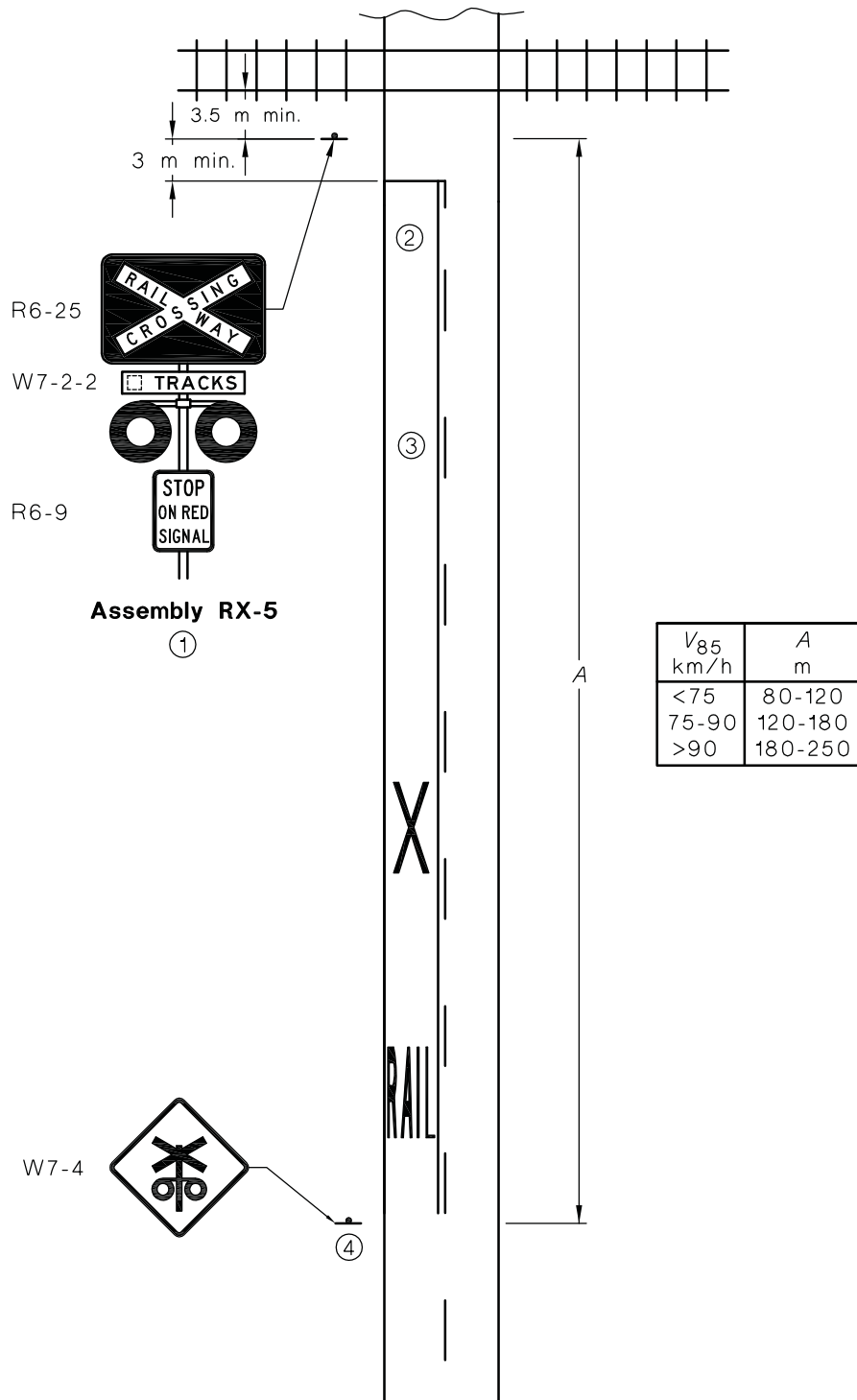

**NOTES:**

- 1 If more than one track, the TRACKS sign, W7-2-1 or W7-2-2, is added to the assembly. The RAILWAY CROSSING position sign may be either the R6-24 or R6-25 sign.
- 2 Stop lines (see Clause 3.3) are required on sealed roads at crossings controlled by flashing lights.
- 3 The barrier line (see Clause 3.5) should extend at least to the W7-4 sign.
- 4 The W7-4 sign may need to be repeated on the right-hand side of the carriageway (see Clause 2.3.3).

**FIGURE 4.7 RAILWAY CROSSING WITH STRAIGHT APPROACH CONTROLLED BY FLASHING LIGHTS (ACTIVE CONTROL)**

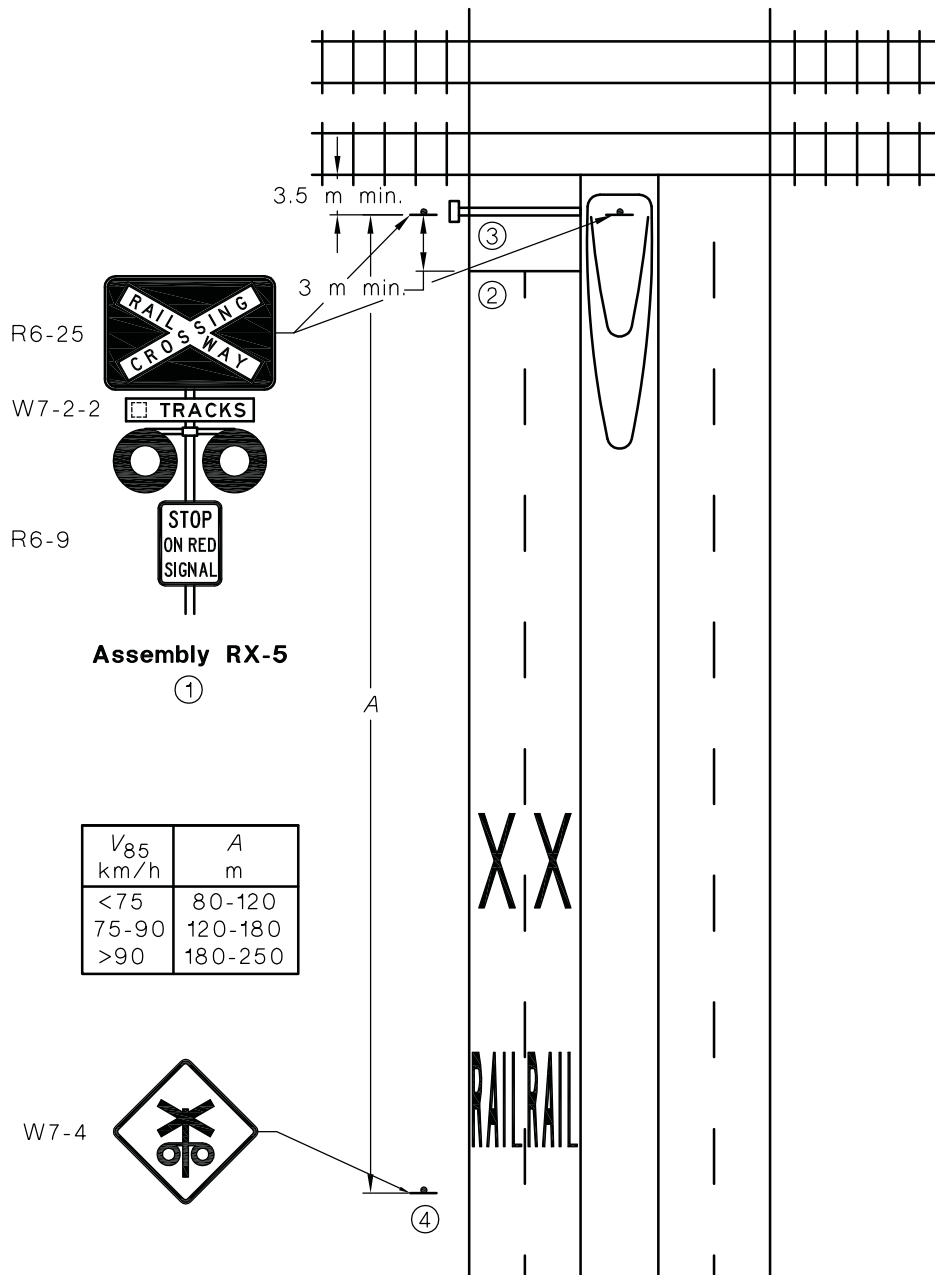

**NOTES:**

- 1 If more than one track, the TRACKS sign, W7-2-1 or W7-2-2, is added to the assembly. The RAILWAY CROSSING position sign may be either the R6-24 or R6-25 sign.
- 2 Stop lines (see Clause 3.3) are required on sealed roads at crossings controlled by flashing lights.
- 3 A boom barrier may be provided (see Clause 2.3.8).
- 4 The W7-4 sign may need to be repeated on the right-hand side of the carriageway (see Clause 2.3.3).
- 5 An overhead flashing signal assembly (Clause 2.3.1) may be needed where there are more than two traffic lanes on the approach.

**FIGURE 4.8 RAILWAY CROSSING WITH STRAIGHT APPROACH CONTROLLED BY FLASHING LIGHTS AND HALF-BOOM BARRIER (ACTIVE CONTROL)**

NOTE: This may be a low-resolution file intended for on-screen viewing only. This file cannot be printed. This file may be one part of a complete technical publication, and should not be read in isolation of the other parts of the publication. A full-resolution version of all parts of the publication can be obtained from the Department of Transport and Main Roads. www.tmr.qld.gov.au The Department of Transport and Main Roads takes no responsibility for any loss or damage resulting from the use of this low-resolution file.

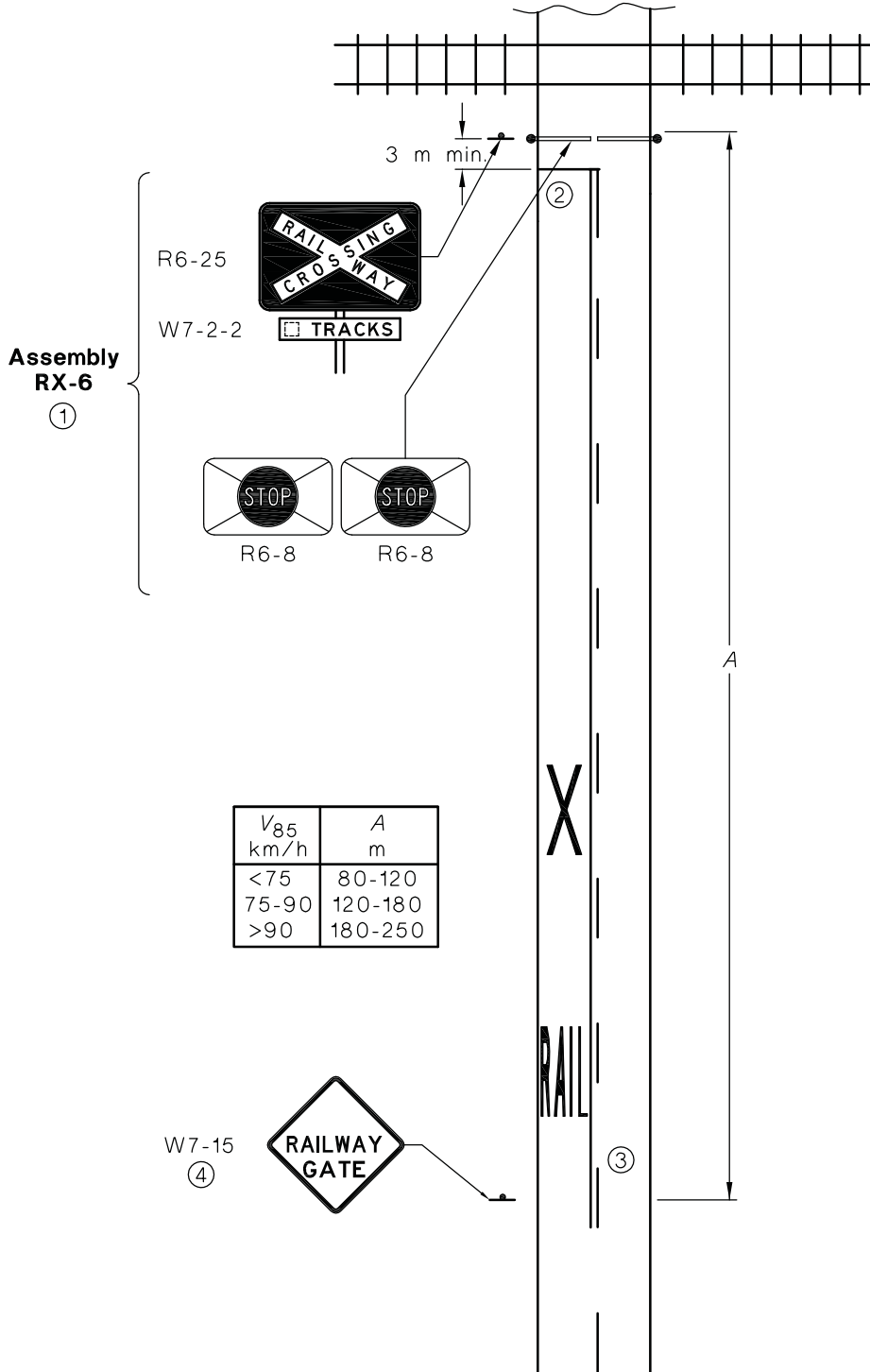

NOTES:

- 1 If more than one track, the TRACKS sign, W7-2-1 or W7-2-2, is added to the assembly. The RAILWAY CROSSING position sign may be either the R6-24 or R6-25 sign.
- 2 Stop lines (see Clause 3.3) are required on sealed roads at crossings controlled by gates.
- 3 The barrier line (see Clause 3.5) should extend at least to the W7-15 sign.
- 4 The W7-15 sign may need to be repeated on the right-hand side of the carriageway (see Clause 2.3.4).

**FIGURE 4.9 RAILWAY CROSSING WITH STRAIGHT APPROACH CONTROLLED BY GATES (ACTIVE CONTROL)**

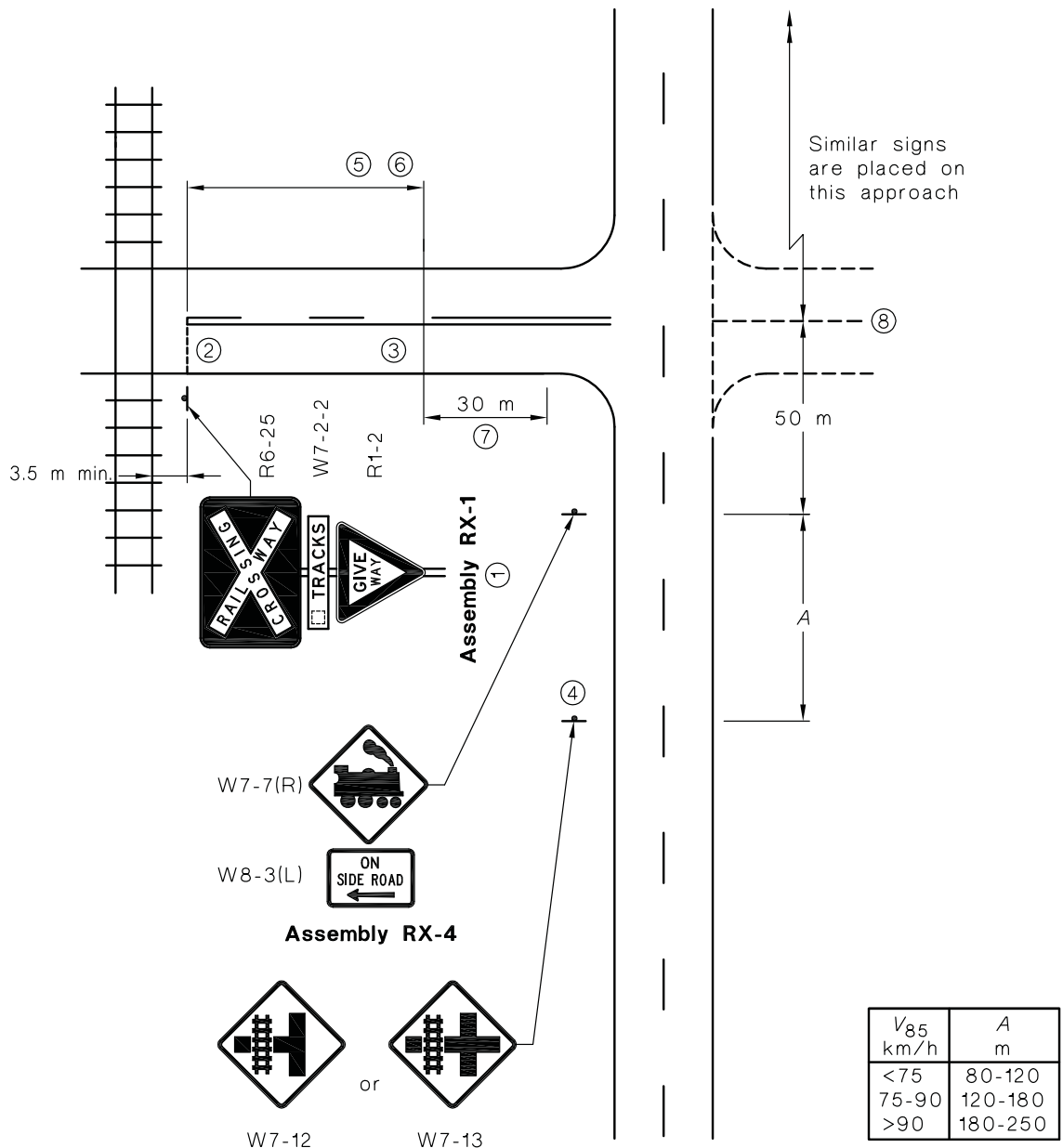

NOTES:

- 1 If more than one track, the TRACKS sign, W7-2-1 or W7-2-2, is added to the assembly. The RAILWAY CROSSING position sign may be either the R6-24 or R6-25 sign.
- 2 A give-way line shall be provided in accordance with Clause 3.4 to indicate the safe position for vehicles to stop, if necessary, to avoid conflict with a train.
- 3 The barrier line (see Clause 3.5) extends from the crossing to the through road.
- 4 The crossing on side-road diagrammatic sign is required only if the intersection itself requires an intersection warning sign in accordance with Part 2 of the Manual. The various alternatives and uses for these signs are described in Clause 2.2.6.
- 5 If this distance is less than 50 m, the advance signs are placed as shown. If the distance is greater than 50 m but less than (50 + A) m, assembly RX-3-1, 2 or 3 is placed in the side road 50 m from the crossing, with assembly RX-4 only on the through road. If the distance is greater than (50 + A) m, all signs are placed in the side road in accordance with Figure 4.4.
- 6 If this distance is 25 m or less, an additional assembly RX-1 may be required (see Clause 4.4.1).
- 7 This dimension is measured from the point at which turns into the side road are completed. A single continuous line over this length may be substituted for the two-way barrier line.
- 8 Advance warning of the railway crossing is not required on this approach.

**FIGURE 4.10 RAILWAY CROSSING ON A SIDE ROAD CONTROLLED BY GIVE WAY SIGNS (PASSIVE CONTROL)**