

# Main Roads Technical Standard

## **MRTS39**

### **Lean Mix Concrete Sub-base for Pavements**

## **TRADEMARKS ACKNOWLEDGEMENT**

Terms mentioned in this document that are known or understood to be trademarks, whether registered or not, have been identified. Where trademarks have been confirmed as registered in Australia, this has been indicated by the addition of the ® symbol, otherwise the ™ symbol is used. While all care has been taken to identify trademarks, users should rely on their own inquiries to determine trademark ownership. Use of a term in this document as a trademark should not be regarded as affecting the validity of any trademark.

## **IMPORTANT INFORMATION**

The requirements of this document represent Technical Policy of the department and contain Technical Standards. Compliance with the department's Technical Standards is mandatory for all applications for the design, construction, maintenance and operation of road transport infrastructure in Queensland by or on behalf of the State of Queensland.

This document will be reviewed from time to time as the need arises and in response to improvement suggestions by users. Please send your comments and suggestions to the feedback email given below.

## **FEEDBACK**

Your feedback is welcomed. Please send to [mr.techdocs@tmr.qld.gov.au](mailto:mr.techdocs@tmr.qld.gov.au).

## **DISCLAIMER**

This publication has been created for use in the design, construction, maintenance and operation of road transport infrastructure in Queensland by or on behalf of the State of Queensland.

Where the publication is used in other than the department's infrastructure projects, the State of Queensland and the department gives no warranties as to the completeness, accuracy or adequacy of the publication or any parts of it and accepts no responsibility or liability upon any basis whatever for anything contained in or omitted from the publication or for the consequences of the use or misuse of the publication or any parts of it.

If the publication or any part of it forms part of a written contract between the State of Queensland and a contractor, this disclaimer applies subject to the express terms of that contract.

## **COPYRIGHT**

Copyright protects this publication. Except for the purposes permitted by and subject to the conditions prescribed under the Copyright Act, reproduction by any means (including electronic, mechanical, photocopying, microcopying or otherwise) is prohibited without the prior written permission of the department. Enquiries regarding such permission should be directed to the Pavements, Materials, Geotechnical and Standards Division, Queensland Department of Transport and Main Roads.

© State of Queensland (Department of Transport and Main Roads) 2010



<http://creativecommons.org/licenses/by-nc-nd/2.5/au>

## Table of Contents

	Page
1 INTRODUCTION.....	1
2 DEFINITION OF TERMS .....	1
3 STANDARD TEST METHODS .....	4
4 REFERENCED DOCUMENTS .....	5
4.1 Standards .....	5
4.2 Interpretation of Limiting Values.....	7
5 QUALITY SYSTEM REQUIREMENTS.....	7
5.1 Hold Points, Witness Points and Milestones.....	7
5.2 Conformance Requirements .....	8
6 SUPPLY OF CONCRETE .....	8
6.1 Materials for Concrete .....	8
6.1.1 Cement .....	8
6.1.2 Fly Ash .....	8
6.1.3 Slag.....	9
6.1.4 Fly Ash and Slag in Combination.....	9
6.1.5 Silica Fume .....	9
6.1.6 Water .....	9
6.1.7 Chemical Admixtures.....	9
6.1.8 Aggregates.....	10
6.1.9 Aggregate Grading .....	12
6.2 Supply and Storage of Materials .....	13
6.2.1 Cementitious Materials .....	13
6.2.2 Aggregates.....	13
6.2.3 Chemical Admixtures.....	14
6.3 Concrete Standards.....	14
6.3.1 Cementitious Content and Component Requirements .....	14
6.3.2 Concrete Compressive Strength.....	14
6.3.3 Consistence .....	15
6.3.4 Drying Shrinkage .....	15
6.3.5 Air Content.....	15
6.3.6 Bleeding.....	15
6.3.7 Restrictions on Chemical Content .....	15
6.4 Concrete Mixes.....	15
6.4.1 General .....	15
6.4.2 Concrete Mix design and Testing .....	15
6.4.3 Hierarchy of Concrete Mixes .....	16
6.4.4 Submission of Proposed Job Concrete Mixes.....	16
6.4.5 Variations to the Job Mix .....	17
6.5 Production and Transport of Concrete .....	17
6.5.1 General .....	17
6.5.2 Handling, Storage and Batching of Materials .....	18
6.5.3 Mixers and Agitation Equipment.....	18
6.5.4 Mixing.....	18
6.5.5 Charging the Mixer .....	19
6.5.6 Retempering .....	19
6.5.7 Mixing Time Limits.....	20
6.5.8 Maximum Forming Time .....	21
6.5.9 Transport and Delivery .....	21
7 CONFORMANCE TESTING OF CONCRETE PRODUCTION AND SUPPLY .....	21
7.1 General.....	21
7.2 Aggregates .....	21
7.3 Air Content.....	22
7.4 Consistence .....	22

8	CONSTRUCTION OF SUBGRADE BEAMS.....	23
8.1	General .....	23
8.2	Excavation .....	23
8.3	Concrete .....	23
8.4	Steel Reinforcement .....	23
8.5	Placement of Concrete .....	23
8.6	Protection.....	24
8.7	Curing .....	24
9	PAVING CONCRETE IN SUB-BASE.....	24
9.1	Curing Compounds.....	24
9.1.1	Types of Curing Compounds .....	24
9.1.2	Technical Standard for Curing Compounds.....	24
9.1.3	Conformance of Compounds .....	25
9.1.4	Supply and Storage.....	25
9.2	Mechanical Paver .....	26
9.3	Placing Operations .....	26
9.3.1	General .....	26
9.3.2	Temperature and Rain .....	27
9.3.3	Underlying Surface Conditions for Placement of Concrete .....	27
9.3.4	Mechanical Paving .....	28
9.3.5	Hand-Placing.....	28
9.3.6	Finishing Operations .....	29
9.3.7	Prevention of Moisture Loss .....	29
9.3.8	Placement of Base Concrete Prior to Achievement of Sub-Base Specified Strength .....	31
9.4	Geometric Standards.....	31
9.4.1	Horizontal Alignment Tolerances .....	31
9.4.2	Surface Smoothness Including 3 m and 150 mm Straight-Edge Tolerances .....	31
9.4.3	Surface Heights.....	31
9.4.4	Thickness .....	31
9.4.5	Inspection.....	32
9.4.6	Rectification.....	32
9.5	Curing by Application of Liquid Membrane-Forming Compound.....	32
9.5.1	Method of Application.....	32
9.5.2	Rate of Application .....	32
9.5.3	Integrity of Membrane .....	32
9.6	Protection of Work .....	33
9.6.1	Weather Protection .....	33
9.6.2	Trafficking of Subbase Concrete.....	33
9.7	Trial Lengths .....	33
9.8	Concrete Sub-base Cracking.....	34
9.8.1	Typical Sub-base Cracking .....	34
9.8.2	Plastic Shrinkage Cracks .....	34
9.8.3	Additional Longitudinal and Transverse Cracks .....	34
10	CONCRETE PAVEMENT JOINTS.....	34
10.1	Transverse Construction Joints.....	34
10.2	Longitudinal Construction Joints .....	35
10.3	Inspection .....	35
11	BITUMINOUS SEAL PROTECTION LAYER .....	35
11.1	General.....	35
11.2	Bitumen Seal Protection Layer.....	36
11.3	Materials .....	36
11.4	Application .....	36
11.5	Thickness of Bituminous Seal .....	36
12	CONFORMANCE TESTING OF PLACED CONCRETE.....	36
12.1	General.....	36
12.2	Concrete Strength .....	37
12.2.1	Test Specimens .....	37
12.2.2	Frequency and Location of Coring.....	37

12.2.3	Determination of Compression Strength .....	37
12.2.4	Restoration of Core Holes .....	37
12.3	Geometric Standards .....	37
12.3.1	Horizontal Alignment Tolerances.....	37
12.3.2	Straight-Edge Tolerances .....	38
12.3.3	Surface Height .....	38
12.4	Curing Compound Rate of Application.....	39
13	MONITORING TESTING.....	39
14	RECTIFICATION .....	40
14.1	Removal and Replacement of Sub-base .....	40
14.1.1	Marking of Sections .....	40
14.1.2	Sawing and Removing Nonconforming Sections .....	40
14.2	Rectification of Finished Sub-base Surface .....	40
15	UTILISATION OF A NONCONFORMING LOT FOR A REDUCED LEVEL OF SERVICE .....	40
15.1	Concrete Strength .....	40
15.2	Reduced Pavement Thickness .....	41
15.3	Plastic Shrinkage Cracking .....	41
16	LOT SIZES AND TESTING .....	41
16.1	General.....	41
16.2	Lots.....	41
16.2.1	General .....	41
16.2.2	Concrete Lots.....	42
16.2.3	Aggregate Lots .....	42
16.3	Lot Sizes, Tests and Testing Frequencies.....	42
16.3.1	General .....	42
16.3.2	Constituent Materials .....	42
16.3.3	Coarse Aggregates.....	43
16.3.4	Fine Aggregate Testing of Source Rock for Manufactured Sands .....	43
16.3.5	Fine Aggregates .....	44
16.3.6	Combined Aggregate.....	44
16.3.7	Alkali Reactive Testing .....	44
16.3.8	Concrete Production and Supply .....	45
16.3.9	Protection Layer Treatment .....	45
16.3.10	Placement of Concrete Sub-Base .....	45
16.3.11	Pavement Joints .....	46



# Lean Mix Concrete Sub-base for Pavements

## 1 INTRODUCTION

This Technical Standard applies to the construction of concrete road pavements.

This Technical Standard shall be read in conjunction with MRTS01 *Introduction to Technical Standards*, MRTS50 *Specific Quality System Requirements* and other Technical Standards as appropriate.

This Technical Standard forms part of the Main Roads Specifications and Technical Standards Manual.

## 2 DEFINITION OF TERMS

The terms in this Technical Standard shall be as defined in the references listed below, with possible conflict of definition being resolved by prioritising them in order of the listing –

- a) As in Table 2 below;
- b) MRTS01 *Introduction to Technical Standards*; and
- c) AS 1348-2002 Glossary of Terms – Roads and Traffic Engineering

The terms and symbols used in this Technical Standard are defined in Table 2.

**Table 2 – Definition of Terms**

Term	Definition
Agitator	An item of plant or equipment which maintains the plastic concrete in the mixed state.
AS size	Sieve size conforming to AS 1152 Specification for Test Sieves.
Average Strength ( $f_{cm}$ )	The arithmetic mean of the compressive strengths influenced by two or more specimen cylinders taken from the same sample.
Base course	A course or courses primarily intended to directly support the traffic loads within the pavement structure and concrete shoulders.
Batch	One load or charge of a mixing plant or transit mixer.
Batching	The process of combining the concrete ingredients in fixed proportions by weight or by volume, including charging and mixing.
Cementitious Materials	Portland cement with possible combinations of fly ash and/or slag in accordance with this Technical Standard.
Central Concrete Mixer	A central mixer which is permanently located adjacent to the manufacturer's batching equipment.
Class of Concrete Work	Concrete that complies with a particular set of Technical Standard requirements as detailed herein e.g. base concrete, slab anchor concrete, non-integral shoulder concrete.
Completion of Batching	For stationary batch mixers, this shall be the time when the batch is discharged into the delivery truck. For mobile mixers, it shall be the time when mixing and slump adjustment ceases at the batching plant, or 10 minutes after the commencement of mixing, whichever occurs first.
Concrete	A thoroughly mixed combination of cementitious materials, aggregates and water, with or without the addition of chemical admixtures or other materials, all of which separately and when combined comply with the requirements of this Technical Standard.
Concrete Base	A base consisting of concrete which has been designed and constructed in accordance with this Technical Standard.

<b>Term</b>	<b>Definition</b>
Concrete Mixers	Mixers conforming to Clause 3.4 of AS 1379 and using the batching process.
Continuously Reinforced Concrete (CRC) Base	A concrete base without contraction joints and reinforced with continuous longitudinal deformed steel in accordance with the Drawings.
Course	One or more layers of the same material within a pavement structure.
Delivery Time	The elapsed time measured from the completion of batching to the arrival at site within 100 m of the point of placement.
Dowels	Smooth steel bars which provide load transfer across joints.
Formed Joint	All joints except for induced joints. This includes slip-formed and fixed-formed joints and edges.
Forming Time	The elapsed time measured from the Completion of Batching to the incorporation of the concrete into the Works, including compaction and final forming, but excluding hand finishing and texturing (where applicable).
Free Edge	This term is used in the context of limiting all restraint against an edge and also the movement of joints which intersect that edge or joint. A free edge is provided by an isolation joint or by an outer edge. Untied butt joints and dowelled expansion joints do not constitute free edges.
Haul Time	The elapsed time measured between the completion of batching and the completion of discharge of the mix.
Integral Shoulder	A concrete shoulder which is made up of the same concrete and is the same thickness as the base pavement, is cast integrally with the base pavement (see Austroads <i>Pavement Design Guide</i> , Clause 9.3.5) and is a minimum of 0.6 m wide. This is deemed to be a structural concrete shoulder.
Job Mix(es)	The proposed job mix(es) which comply with all the specified requirements.
Jointed Reinforced Concrete (JRC) Base	A concrete base incorporating mesh reinforcement in all slabs and dowels at transverse joints.
Jointed Un-reinforced or Plain Concrete Base	A concrete base which contains no reinforcement other than tie bars across longitudinal joints and with transverse contraction joints, without dowels, induced at the specified intervals. There can be reinforcing mesh in specified slabs.
Layer	The portion of a pavement course placed and completed as an entity.
Lean Mix Concrete Sub-base	A sub-base consisting of lean mix concrete which has been designed and constructed in accordance with MRTS39 <i>Lean Mix Concrete Sub-base for Pavements</i> .
Load	A single truck load of concrete comprising one or more batches.
Lot	As defined in Clause 16.2 of this Technical Standard.
Lower Subgrade	The layer beneath the controlled subgrade.
Mechanical Paver	Pavers used for the construction of sub-base and conforming to Clause 9.2. Pavers referred to as slip-form pavers which comply with Clause 9.2 may be used.
Mesh	Wire fabric complying with AS/NZS 4671.
Mixing Time	Applicable to batch mixers only; the mixing time for each batch shall be measured from the time all the ingredients are in the mixing drum until the time mixing at the specified rate, or after specified revolutions, ceases.
Mobile Concrete Mixer	A mixer where mixing is carried out entirely in a truck-mounted drum mixer which is integral with, or can be connected to, a prime mover.

Term	Definition
Nominated Job Mix	The job mix(es) accepted for use on the Works and nominated for use for a specified period.
Non-structural Shoulder	A shoulder (concrete or otherwise) which is not considered to reduce stresses in the structural pavement sufficient to decrease the base thickness. It is de-bonded from the concrete base (except for nominal tie bars in the case of a concrete non-integral shoulder).
Pavement	The portion of the road, including shoulders placed above the subgrade, which supports and forms a running surface for vehicular traffic.
Proposed Job Mix(es)	The mix(es) which the contractor has submitted for use in the Works.
Relief Edge	An edge which relieves contraction stresses in joints and/or sections aligned parallel to that edge.
Retempering	The addition of water after the completion of batching.
Sample	A portion of material drawn from a lot, in accordance with any relevant Technical Standard, test method or AS requirements, for the purpose of testing.
Shoulder	The portion of the pavement contiguous to and flush with the structural pavement.
Slag Aggregate	Air-cooled iron blast-furnace slag aggregate.
Slag Cement	Ground, granulated iron blast-furnace slag cementitious material.
Specimen Beam	A single concrete beam made from a sample for the purpose of flexural strength testing.
Standard Deviation (s)	A statistical measure of the variation from the mean of the samples.
Steel Fibre Reinforced Concrete (SFRC) Base	A concrete base which incorporates steel fibre reinforcement. The steel fibres are distributed with random orientation throughout the concrete. SFRC is treated similarly to JRC.
Structural Pavement	The concrete running lanes within the geometric edge line, any structural concrete shoulder and any integral widening outside the geometric edge line.
Structural Shoulder	A fully tied shoulder which is also keyed (corrugated) and has a minimum width of 3 m, or is an integral shoulder.
Sub-base (Course)	A portion of the pavement immediately beneath the base.
Subgrade	The prepared formation beneath the working platform or, where there is no working platform, beneath the lowest pavement layer where such a layer is in accordance with a QDMR Technical Standard for pavements.
Substrate	The layer immediately beneath the lean mix concrete sub-base.
Surface Evenness	The roughness of the pavement surface in counts/km as measured by Austroads Roughness Meter.
Testing Station	The agreed location for the taking of samples as specified herein.
Tied Shoulder	A concrete shoulder which is made up of the same concrete and is the same thickness as the base pavement, which is formed, debonded and nominally tied to the base pavement and is a minimum of 1.4 m wide.
Trafficked Pavement	That part of the pavement, bounded by longitudinal joints, which lies either totally or in part within the trafficked carriageway as defined by lane lines.

Term	Definition
Trafficked Slab	A slab transversely bounded by longitudinal joints or edges or a longitudinal joint and an edge and which lies either totally or in part within the trafficked carriageway as defined by lane lines. For other than continuously reinforced pavements, a slab is bounded longitudinally by the planned transverse joints.
Transition Lot	As defined in Clause 16.2.2
Transition Point	The point at which vibration on a paving machine is turned off or ceases effective compaction. (See Clause 16.2.2.)
Trial Mix(es)	The mix(es) proposed for use in the Works
Verge	That portion of the road adjacent to the shoulder.
Wearing (Running) Course	The pavement course which is in direct contact with the vehicular traffic.
Wet Curing	Curing at ambient temperature when the concrete surface is, in effect, being covered with water or placed in a fog room/chamber with a relative humidity exceeding 98%.
Yielded Cubic Metre of Concrete	The exact constituents (including all components and their masses) required to make up a cubic metre of concrete for each job mix, based on a determination of mass per unit volume in accordance with AS 1012.5, using internal vibration.

### 3 STANDARD TEST METHODS

The standard test methods given in Table 3 shall be used in this Technical Standard.

Further details of test numbers and test descriptions are given in MRTS01 *Introduction to Technical Standards*.

Where there are requirements in this Technical Standard and/or any other Technical Standards in addition to or which modify the requirements of any test method, Australian Standard or other referenced standard or document; the requirements of this Technical Standard and then those of the other Technical Standards shall apply and override the test methods, standards or other documents and shall form part of the contract for this project.

**Table 3 – Referenced QDMR Test Methods**

Number	Test Method Title
Q105	Plasticity Limit and Plasticity Index
Q201	Flakiness Index (General)
Q202	Average Least Dimension
Q205A	Determination of the Ten Percent Fines Value (Dry)
Q205B	Determination of the Ten Percent Fines Value (Wet)
Q205C	Wet/Dry Strength Variation
Q208B	Degradation Factor (Coarse Aggregate)
Q215	Crushed Particles
Q471	Making, Curing and Testing Moulded Specimens with Field Simulated Curing.
Q458	Alkali-Silica Reactivity
Q460A	Compressive Stress and Recovery of Preformed Joint Filler
Q460B	Extrusion of Preformed Joint Filler
Q460C	Expansion of Preformed Self-Expansive Joint Filler

Number	Test Method Title
Q460D	Accelerated Weathering of Preformed Joint Filler
Q460E	Resistance to Heat Degradation of Closed-Cell Foam Joint Filler
Q460F	Resistance to Disintegration of Preformed Cork Joint Filler
Q461	Durability of Sealant
Q462	Resistance of Vulcanised Rubber to the Absorption of Oil
Q463A	High Temperature Recovery of Preformed Polychloroprene Elastomeric Joint Seals for Bridge Structures
Q463B	Low Temperature Recovery of Preformed Polychloroprene Elastomeric Joint Seals
Q470	Coefficient of Thermal Expansion of Concrete
Q472	Making and Curing Concrete Compressive, Indirect Tensile and Flexural Test Specimens
Q473	Density of Hardened Concrete (Water Displacement)
Q630	Qualitative Analysis of Materials (Infra-Red Spectrophotometry)
Q705	Texture Depth of Road Surfacing (Sand Patch)
Q708	Road Roughness – Surface Evenness
Q709	Determination of the Profile Factor for Surface Evenness (Digital One Metre Profile Beam)

## 4 REFERENCED DOCUMENTS

### 4.1 Standards

Table 4.1 lists the documents referenced in this Technical Standard.

**Table 4.1 – Referenced Australian Standards**

Reference	Title
AS 1012.1	Methods of Testing Concrete – Sampling of Fresh Concrete
AS 1012.3.1	Methods of Testing Concrete –Determination of Properties Related to the Consistency of Concrete – Slump Test
AS 1012.3.3	Methods of Testing Concrete –Determination of Properties Related to the Consistency of Concrete – Vebe Test
AS 1012.4.2	Methods of Testing Concrete – Determination of Air Content of Freshly Mixed Concrete – Measuring Reduction in Air Pressure in Chamber above Concrete
AS 1012.5	Methods of Testing Concrete –Determination of Mass per Unit Volume of Freshly Mixed Concrete
AS 1012.9	Methods of Testing Concrete –Determination of the Compressive Strength of Concrete Specimens
AS 1012.11	Methods of Testing Concrete – Determination of the Modulus of Rupture
AS 1012.13	Methods of Testing Concrete – Determination of the Drying Shrinkage of Concrete for Samples Prepared in the Field or in the Laboratory
AS 1012.14	Methods of Testing Concrete – Method for Securing and Testing Cores from Hardened Concrete for Compressive Strength
AS 1012.20	Methods of Testing Concrete – Determination of Chloride and Sulfate in Hardened Concrete and Concrete Aggregates
AS 1141.0	Methods for Sampling and Testing Aggregates – List of Methods

<b>Reference</b>	<b>Title</b>
AS 1141.1	Methods for Sampling and Testing Aggregates – Definitions
AS 1141.2	Methods for Sampling and Testing Aggregates – Basic Testing Equipment
AS 1141.3.1	Methods for Sampling and Testing Aggregates – Sampling – Aggregates
AS 1141.4	Methods for Sampling and Testing Aggregates – Bulk Density of Aggregate
AS 1141.5	Methods for Sampling and Testing Aggregates – Particle Density and Water Absorption of Fine Aggregate
AS 1141.6.1	Methods for Sampling and Testing Aggregates – Particle Density and Water Absorption of Coarse Aggregate – Weigh-in-Water Method
AS 1141.6.2	Methods for Sampling and Testing Aggregates – Particle Density and Water Absorption of Coarse Aggregate – Pycnometer Method
AS 1141.11	Methods For Sampling And Testing Aggregates – Particle Size Distribution By Sieving
AS 1141.12	Methods for Sampling and Testing Aggregates – Materials Finer than 75 µm in Aggregates (by Washing)
AS 1141.13	Methods for Sampling and Testing Aggregates – Material Finer than 2 µm
AS 1141.14	Methods for Sampling and Testing Aggregates – Particle Shape, by Proportional Calliper
AS 1141.15	Methods for Sampling and Testing Aggregates – Flakiness Index
AS 1141.31	Methods for Sampling and Testing Aggregates – Light Particles
AS 1141.32	Methods for Sampling and Testing Aggregates – Weak Particles (Including Clay Lumps, Soft and Friable Particles) in Coarse Aggregates
AS 1141.34	Methods for Sampling and Testing Aggregates – Organic Impurities other than Sugar
AS 1141.35	Methods for Sampling and Testing Aggregates – Sugar
AS 1152	Specification for Test Sieves
AS 1289.0	Methods of Testing Soils for Engineering Purposes – General Requirements and List of Methods
AS 1289.4.2.1	Methods of Testing Soils for Engineering Purposes – Soil Chemical Tests – Determination of the Sulphate Content of a Natural Soil and the Sulphate Content of the Ground Water – Normal Method
AS 1348	Glossary of terms – Roads and Traffic Engineering
AS 1379	Specification and Supply of Concrete
AS 1478.1	Chemical Admixtures for Concrete, Mortar and Grout – Admixtures for Concrete
AS 1554.3	Structural Steel Welding – Welding of Reinforcing Steel
AS 1726	Geotechnical Site Investigations
AS 2350.2	Methods of Testing Portland and Blended Cements – Chemical Composition of Portland Cement
AS 2706	Numerical Values – Rounding and Interpretation of Limiting Values
AS 2758.1	Aggregates and Rock for Engineering Purposes – Concrete Aggregates
AS 3582.1	Supplementary Cementitious Materials for Use with Portland and Blended Cement – Fly Ash
AS 3582.2	Supplementary Cementitious Materials for Use with Portland Cement – Slag – Ground Granulated Iron Blast-Furnace
AS 3600	Concrete Structures

Reference	Title
AS 3700	Masonry Structures
AS 3799	Liquid Membrane-Forming Curing Compounds for Concrete
AS 3972	Portland and Blended Cements
AS/NZS 4671	Steel Reinforcing Materials
AS/NZS 4680	Hot-dip galvanized (zinc) coatings on fabricated ferrous articles

#### 4.2 Interpretation of Limiting Values

Unless otherwise stated, limiting values and the rounding of test values shall be interpreted in accordance with MRTS01 *Introduction to Technical Standards*.

### 5 QUALITY SYSTEM REQUIREMENTS

#### 5.1 Hold Points, Witness Points and Milestones

General requirements for Hold Points, Witness Points and Milestones are specified in Clause 5.2 of MRTS01 *Introduction to Technical Standards*.

The Hold Points, Witness Points and Milestones applicable to this Technical Standard are summarised in Table 5.1.

**Table 5.1 – Hold Points and Witness Points**

Clause	Hold Point	Witness Point	Milestone
6.4.3.2			Submission of proposed job mix(es)
6.4.3.3	1. Suitable job mix(es)		
6.5.4.1	2. Demonstrated mix procedures and uniformity		
8.4	3. Reinforcement		
9.2		Monitoring mechanical paver	
9.3.1.	4. Intention to commence construction		
9.3.3.2	5. Submission of measured heights		
9.5.1		Commencement of curing	
9.6.2	6. Rectification of damage to sub-base, if any		
9.7			Submission of proposed construction procedure
9.7	7. Acceptance of proposed plant, materials and construction methods		
9.7	8. Acceptance of trial section into the Works		
14.1.1	9. Proposed method for rectification		

## 5.2 Conformance Requirements

The manufacture and placement of concrete and all constituent materials shall be administered on the basis of lots (see MRTS01 *Introduction of Technical Standards* and MRTS50 *Specific Quality System Requirements*), which shall be clearly identified and recorded.

For materials tested at the point of manufacture (such as steel, admixtures and curing compounds), test certificates shall be obtained and held on site.

Conformance testing of all other materials, including aggregates and mixed concrete, shall be carried out on lots at the batching site. However, if an aggregates' manufacturer has third-party quality assurance, compliance testing may be carried out at the point of manufacture.

All quality assurance records (including test results) shall be maintained on a computer system which shall also include the capacity to summarise, graph and carry out statistical calculations on the data.

In addition to the tests specified in this Technical Standard, charts shall be maintained for at least those in Table 5.2 following:

**Table 5.2 – Minimum Charting Requirements**

Item	Requirement	Referenced Clause
Combined Aggregate	Percent passing AS sieve size 0.075 mm	6
Concrete	a) Slump	7.4
	b) Height of Sub-base	9.4.3
	c) Core Strength	12.2

The charts shall include the following –

- a) the actual results with the maximum tolerances;
- b) a five-point running mean, with limits set at 0.7 multiplied by the maximum tolerances; and
- c) a five-point running range (highest from the lowest)

Lot sizes and testing requirements are specified in Clause 16.

## 6 SUPPLY OF CONCRETE

### 6.1 Materials for Concrete

#### 6.1.1 Cement

All cement shall be of Australian manufacture and shall conform with Types GB, GP or SL in AS 3972, Portland and Blended Cements.

The Contractor shall obtain documentary evidence from the cement supplier regarding the source and conformance to AS 3972 of all cement used in the sub-base concrete and include this documentation in the job mix submission [refer **Hold Point 1**].

#### 6.1.2 Fly Ash

The use of fly ash is mandatory and its use is subject to the following conditions –

- a) The Contractor shall nominate an intention to use fly ash (either separately or as blended cement) in the sub-base, and in all cases state the proportions when submitting details of the mix design;
- b) Fly ash shall conform to AS 3582.1 'fine grade', except that 'medium grade' is permissible in the absence of an air entraining agent; and
- c) In addition to the requirements of AS 3582.1, the fly ash shall have a percent passing the AS sieve size 0.045 mm of not more than 95%.

Documentary evidence from the source and conformance to the above requirements shall be included in the job mix submission. Where the Contractor or supplier proposes to use both fly ash and an air entraining agent in a job mix, the supplier shall provide the Administrator with proof that the amount of air entrained can be controlled within specified limits and that the compressive strength is satisfactory. This proof shall include

the limits on fineness and loss on ignition necessary to achieve the specified level of air entrainment with the proposed level of fly ash. These limits shall be included in the Technical Standard for the Works and shall be included in the job mix submission [refer Hold Point 1].

The Contractor shall also assure himself that the requirements of this Clause are achievable before submitting the tender.

The Contractor shall obtain from the fly ash supplier, and shall include in the quality records, documentary evidence regarding the source and conformance to AS 3582.1 of all fly ash used in the concrete.

The Contractor's Quality Plan shall detail how fly ash supply shall be monitored for conformance to this Clause.

### 6.1.3 Slag

Ground granulated iron blast-furnace slag may be used in concrete, subject to the following conditions –

- a) The Contractor shall nominate an intention to use slag (either separately or as blended cement) and state the proportions when submitting details of the mix design; and
- b) Slag shall conform to AS 3582.2.

The Contractor shall obtain from the slag supplier, and shall include in the quality records, documentary evidence regarding the source and conformance to AS 3582.2 of all slag used in the concrete and this documentary evidence shall be included in the job mix submission [refer Hold Point 1].

### 6.1.4 Fly Ash and Slag in Combination

Fly ash and slag in combination may be used in concrete, provided that the Contractor nominates an intention to use both fly ash and slag in combination with Portland cement, and states the proportions when submitting details of the mix design.

### 6.1.5 Silica Fume

Silica fume shall not be used in any concrete either as an addition, or in isolation or as a component of any material such as Portland cement as defined in AS 3972, Clause 4.2.

### 6.1.6 Water

Water used in the production of concrete shall be free from materials harmful to concrete, and be neither salty nor brackish.

The water shall conform to AS 1379, Table 4, 'Limits for Impurities in Mixing Water', except for the following –

- a) maximum 500 parts per million of chloride ion determined by AS 1478.1 Appendix C; and
- b) maximum 400 parts per million of sulphate ion determined by AS 1289.4.2.1.

### 6.1.7 Chemical Admixtures

#### 6.1.7.1 General

Chemical admixtures shall comply with AS 1478.1 and shall be used in accordance with AS 1379. Admixtures shall not contain calcium chloride, calcium formate, triethanolamine or any other accelerator, unless approved in writing by the Administrator.

Admixtures or combinations of admixtures, other than specified below, shall not be used except the use of superplasticisers or high range water reducers – Type HRWRRe (restricted to warm seasons in accordance with Clause 6.1.7.3) or Type WRRe (conforming to AS 1478.1) shall be permitted as appropriate under this Technical Standard.

The Contractor shall ensure and certify that admixtures used in concrete production are the same as those for which Certificates of Conformance have been obtained. **Witness Point**

The total alkali contribution (measured as Na<sub>2</sub>O equivalent) of all admixtures used in a mix shall not exceed 0.20 kg/m<sup>3</sup>.

Where combinations of two or more admixtures are proposed in a mix, their compatibility shall be certified in writing by the manufacturers and this certification shall be included in the job mix submission [refer Hold Point 1].

### 6.1.7.2 Air Entrainment

Air entrainment is optional in sub-base concrete mixes but, if incorporated, shall be in accordance with the manufacturer's directions. Where an air entraining agent is incorporated in the sub-base mixes, the air content of the concrete delivered on site shall achieve an air content of 5.0% ± 2.0% when tested in accordance with AS 1012.4.2 with compaction by internal vibration. **Witness Point**

The Contractor shall provide an air content gauging device at the site so that the air content of the freshly mixed concrete may be accurately determined in accordance with AS 1012.4.2.

### 6.1.7.3 Water-Reducing Retarding Admixtures

During the warm season (typically September to May inclusive, unless agreed to otherwise with the Administrator) a lignin or lignin-based ('ligpol') set-retarding admixture (Type Re or WRRe) shall be used, in accordance with the manufacturer's instructions. The dosage shall be varied to account for air temperature and haul time in accordance with the manufacturer's recommendations. Superplasticisers and high range water reducers, Type HRWRRe, may also be used. The Contractor shall obtain a NATA-endorsed Certificate of Conformance to AS 1478.1 for admixtures of Type Re or Type WRRe.

During the cooler season (typically June to August inclusive, unless the Administrator agrees to otherwise) only a lignin containing not more than 6% reducing sugars (Type WR complying with AS 1478.1) may be used in the mix. If the Contractor proposes to vary the admixture between the warm and cool seasons, such variation shall constitute a permitted variation to the nominated mix in terms of Clause 6.4.5.

The Contractor's Quality Plan shall provide details of the criteria (such as temperature) which may be used to initiate changes in admixture type with season.

## 6.1.8 Aggregates

### 6.1.8.1 General

Documentary evidence of the conformance to this Technical Standard of the source material for the aggregates shall be included in the job mix submission **[refer Hold Point 1]**.

The Contractor shall nominate the grading of the aggregate which shall be subject to the limitations of grading envelopes given in this Technical Standard.

### 6.1.8.2 Aggregate Source Assessment

The Contractor shall provide a material source assessment of the proposed material components to be used as concrete aggregate, including an investigation of geological site characteristics and source material properties.

The source material shall be classified into one of the source material groups defined in Table 6.1.8.2 and the material source assessment shall show that material meeting the source material requirements of this Technical Standard can be produced. Where aggregate components are to be supplied from more than one source, a material source assessment of each source shall be provided.

Due to the variable nature of most material sources, the assessment shall indicate the presence of materials with properties superior to the source material standards specified in this Technical Standard to allow for such variability, and hence to ensure that the requirements for the concrete aggregate in the stockpile(s) and/or other nominated storage points are satisfied **[refer Hold Point 1]**.

**Table 6.1.8.2 – Terms for Assessing Material Source for Aggregates**

Term	Definition
Acid Igneous Rock	As defined in AS 1726. Includes Rhyolite, Dacite, Tuffs (of same composition), Granite, Adamellite and Granodiorite.
Basic Igneous Rock	As defined in AS 1726. Includes Basalt, Dolerite and Gabbro.
Intermediate Igneous Rock	As defined in AS 1726. Includes Trachyte, Trachyandesite, Andesite, Tuffs (of same composition), Syenite and Diorite.
Material Group	A category selected on the basis of material classification, geological processes and source material properties.

Term	Definition
Material Source	A quarry or pit from which concrete aggregate is won by blasting, ripping or other excavation means. The aggregate will have to be processed by crushing and/or screening before use.
Metamorphic Rock	As defined in AS 1726. Includes Hornfels, Quartzite, Metagreywacke, Greenstone, Slate and Amphibolite.
Natural Gravel	Naturally occurring colluvial or alluvial gravels.
Sedimentary and Duricrust Rocks	As defined in AS 1726. Includes Limestones, Dolomite, Mudstone, Arenite, Chert and Silcrete.

### 6.1.8.3 Coarse Aggregates

Coarse aggregates shall consist of clean, cuboidal, durable, natural gravel; crushed stone, or combinations thereof; and shall conform to AS 2758.1, including assessment for alkali-reactive materials.

Slag aggregate shall not be used.

Coarse aggregate shall conform to the requirements of Table 6.1.8.3-A and Table 6.1.8.3-B and Clause 6.1.8.5.

If the Contractor proposes to blend two or more coarse aggregates, coarse aggregate from each source shall comply with all the requirements of this Technical Standard, except grading. The combined grading of the coarse aggregate shall comply with all the requirements of Clause 6.1.9.1.

**Table 6.1.8.3-A – Coarse Aggregate Requirements: Ten Percent Fines Value; Wet/Dry Variation; Degradation Factor**

Source Material	Requirements		
	Ten Percent Fines Value (Wet) <sup>1</sup> (Minimum kN)	Wet/Dry Strength Variation <sup>1,2</sup> (Maximum %)	Degradation Factor (Coarse Aggregate) (Minimum mm)
Acid Igneous	110	40	40
Intermediate Igneous	120	35	45
Basic Igneous	130	30	50
Metamorphic	120	35	45
Sedimentary, Duricrust, Natural Gravel	110	40	-

Notes –

- The 10% fines value (wet) and wet/dry strength variation tests shall be carried out in accordance with Test Methods Q205B and C respectively on, where possible, the size fraction, AS 13.2 mm – AS 9 mm. Where there is insufficient material for this size fraction, the next lowest fraction where there are sufficient materials shall be used.
- For greenstone source material only (metamorphic group), if the greenstone does not comply with the maximum wet/dry strength variation limits, it may be deemed to comply if its 10% fines value (wet) is 160 kN or greater.

**Table 6.1.8.3-B – Requirements for Coarse Aggregate: Other Properties**

Property	Test Method	Requirement
Bulk Density of Aggregate	AS 1141.4	min. 1200 kg/m <sup>3</sup>
Particle Density and Water Absorption of Coarse Aggregate	AS 1141.6.1 or AS 1141.6.2	max. 2.5%
Materials Finer than 75 µm in Aggregates (By Washing)	AS 1141.12	max. 2.0%
Material Finer than 2 µm	AS 1141.13	max. 1.0%

Property	Test Method	Requirement
Particle Shape, by Proportional Calliper (3:1 ratio) (2:1 ratio)	AS 1141.14	max. 10% max. 35%
Flakiness Index (General)	AS 1141.15	maximum of 25%
Light Particles	AS 1141.31	max. 1.0%
Weak Particles (Including Clay Lumps, Soft and Friable Particles) in Coarse Aggregates	AS 1141.32	max. 0.3%
Alkali-Silica Reactivity	Q458	as per Clause 6.1.8.5

#### **6.1.8.4 Fine Aggregate**

Fine aggregate shall consist of natural sand or a manufactured sand containing not less than 50% natural sands. Particles shall be clean, hard and durable. Fine aggregate shall conform to AS 2758.1, including assessment for alkali-reactive materials. Fine aggregate shall conform to the requirements of Table 6.1.8.4. For manufactured sands, the source rock shall comply with the requirements of Clauses 6.1.8.2. and 6.1.8.3.

Slag aggregate shall not be used.

Fine aggregate shall conform to the requirements of Table 6.1.8.4.

If the Contractor proposes to blend two or more fine aggregates, the fine aggregate from each source shall comply with all the requirements of this Technical Standard except grading. The combined grading of the fine aggregate shall comply with all the requirements of Clause 6.1.8.4.

**Table 6.1.8.4 – Requirements for Fine Aggregate**

Property	Test Method	Requirement
Bulk Density of Aggregate	AS 1141.4	min. 1200 kg/m <sup>3</sup>
Particle Density and Water Absorption of Fine Aggregate	AS 1141.5	max. 2.5%
Material Finer than 75 µm Aggregates (by Washing)	AS 1141.12	max. 5.0%
Material Finer than 2 µm	AS 1141.13	max. 1.0%
Organic Impurities other than Sugar	AS 1141.34	colour to be no darker than the standard colour of the reference solution
Sugar	AS 1141.35	less than 1 part in 10,000
Alkali-Silica Reactivity	Q458	as per Clause 6.1.8.5
Plasticity Index	Q105	max. 2%

#### **6.1.8.5 Alkali Reactive Materials**

In addition to the requirements of AS 2758.1, Clause 10, all nominated concrete mixes shall meet the requirements of the 'innocuous' classification of Test Method Q458. Concrete mixes containing a minimum 20% of an approved fly ash by mass of total cementitious material shall be deemed to comply with this additional requirement.

#### **6.1.9 Aggregate Grading**

##### **6.1.9.1 General**

The Contractor shall submit an aggregate grading determined in accordance with AS 1141.11, known as the 'nominated sub-base grading' which is within the combined aggregate envelope shown in Table 6.1.9.1-A below. The specified grading distributions are based on materials of equal bulk densities in a saturated surface-dry condition. Where bulk densities are unequal, the specified combined particle size distribution shall be adjusted accordingly.

**Table 6.1.9.1-A – Combined Total Aggregate Grading**

AS Sieve (mm)	% by Mass Passing of Sample
26.5	100
13.2	60-90

The grading of the combined aggregate used in the sub-base concrete shall not deviate from the nominated grading by more than that shown in Table 6.1.9.1-B.

**Table 6.1.9.1-B – Allowable Tolerances on Nominated Combined Grading**

AS Sieve	Maximum Deviation (% passing by mass of sample)
26.5 mm	5
19.0 mm	10
13.2 mm	10
4.75 mm	10
1.18 mm	5
600 micrometre	5
150 micrometre	2

## 6.2 Supply and Storage of Materials

### 6.2.1 Cementitious Materials

Cementitious material shall be transported and stored so as to prevent any contamination and to minimise the adverse effect of moisture and high humidity during transportation and storage. Caked or lumpy cementitious material shall not be used.

Where delivery of cementitious material is in bags, they shall be marked with the manufacturer's name, the brand name (if appropriate), the name of the producing works, the material type, the standard to which it was made, and the date of manufacture or date code. Bagged material shall be delivered in the original sealed and branded bags. If bagged material is to be stored in bulk containers, it shall be charged through a 6 mm mesh screen which is welded or bolted to, and covers the entire feed area of, the container's charging hopper.

Cementitious material shall be stored above ground level in dry, weatherproof sheds and be protected from dampness which may be acquired from contact with floors or walls. Bags shall be stacked so as to allow counting, inspection, and identification of each consignment.

Cementitious material shall be used in order of receipt and as soon as possible. The Contractor shall demonstrate a system to ensure freshness, so that material more than two months old shall not be used. Material containing lumps shall be rejected irrespective of age.

### 6.2.2 Aggregates

Aggregates shall be stored in stockpiles. The stockpiles shall be located in clean areas which are paved –

- a) with at least an AMCO prime and a bitumen seal with a 14 mm cover aggregate, designed in accordance with the Austroads Design of Sprayed Seals; and
- b) over a granular pavement complying with MRTS05 *Unbound Pavements*; and which are –
  - i) sufficiently sound to accommodate all loadings;
  - ii) adequately drained to prevent ponding;
  - iii) not liable to flooding; and
  - iv) maintained to the original standard while in use for the Works.

A stockpile shall be a homogeneous portion of material of each component used to make up each of the coarse and fine aggregates to be used in the Works. There shall be a separate stockpile for each component. The various sizes and types of aggregates shall be separated by solid dividing walls of a height and strength sufficient to prevent segregation of a specific aggregate size, or prevent mixing with other aggregate sizes or deleterious materials.

Alternatively, the specific aggregate sizes shall be stored at a sufficient distance apart to prevent intermixing.

An aggregate lot shall consist of a discrete stockpile solely for use on these works. These materials shall not be used for any other Works. The stockpile shall be formed by either of the following methods –

- a) a stockpile for each lot; or
- b) a continuous, rectangular-in-plan-view, shaped stockpile where material is added at one end and withdrawn at the other end, with each lot being identified by pegged locations within the stockpile.

Nonconforming stockpile lots shall be removed from the stockpile prior to the addition of further portions.

Where plant is required to operate on stockpiles, washing and decontamination procedures shall be employed before permitting access to the stockpile. If the Contractor fails to comply with these requirements, the aggregates and/or stockpiles shall be deemed nonconforming and replaced.

Stockpiles of fine aggregate shall be capable of draining freely. Wet/fine aggregate shall not be used until it has drained sufficiently to ensure proper control of the water/cementitious material ratio.

The Contractor shall monitor moisture content of the aggregate at least three times per day and immediately after rain and after any other changes have occurred to the stockpiles, to provide adequate control of the concrete mix.

### **6.2.3 Chemical Admixtures**

The Contractor shall supply for each consignment of chemical admixture a record stating the manufacturer's name and type and quantity of admixture delivered, date manufactured, together with the manufacturer's test certificate showing that the consignment has been tested and analysed, and conforms in all respects to the relevant standard. Admixtures shall be stored in waterproof conditions and used in order of receipt. The Contractor shall comply with any special requirements of the manufacturer of the product. Any admixture which has become stale or unsuitable shall be removed from the site and replaced at the Contractor's expense.

## **6.3 Concrete Standards**

### **6.3.1 Cementitious Content and Component Requirements**

The cementitious content and component requirements shall be in accordance with Table 6.3.1.

**Table 6.3.1 – Cementitious Content and Component Requirements**

<b>Component</b>	<b>Requirement</b>
Fly Ash <sup>1</sup>	min. 40%
Total Cementitious <sup>2</sup>	min. 250 kg/m <sup>3</sup>

Notes –

1 Percentage of fly ash expressed as a percentage of the actual total cementitious material used in the concrete used in the Works.

2 Per yielded cubic metre of concrete.

### **6.3.2 Concrete Compressive Strength**

The minimum in-situ strength of the sub-base within 42 days of placement shall be 5.0 MPa, determined by testing the compressive strength of specimens cut from the Works.

In addition, the compressive strength at age 28 days for the trial mix (see Clause 6.4.2) shall be not less than 6.0 MPa nor greater than 15.0 MPa. The compressive strength shall be the arithmetic mean of individual results. The compressive strength shall be determined in accordance with AS 1012.9, using specimens of 100 mm nominal diameter which have been made and cured in accordance with Test Method Q472, with compaction by internal vibration.

Nonconforming lots which have an insitu strength less than 4.0 MPa within 42 days of placement shall be removed and replaced in accordance with Clause 14.

### 6.3.3 Consistence

The Contractor shall nominate a slump value for each job concrete mix within the range specified below, which will allow the production of a dense, non-segregated mix with bleeding limited so as to prevent bleed water flowing over the slab edge under the conditions of placement.

For mechanically placed concrete, the nominated slump shall be between 20 mm and 50 mm. For hand-placed concrete, the nominated slump shall be between 40 mm and 80 mm.

If more than 70% of the coarse aggregate used in the concrete mix is light-weight aggregate the above ranges shall be reduced to 15 – 45 mm and 25 – 65 mm respectively.

For each job mix which is intended to be mechanically placed, the Vebe value shall be determined in accordance with AS 1012.3.3 and reported. **Witness Point**

### 6.3.4 Drying Shrinkage

The drying shrinkage of each job mix shall be determined after 21 days air drying (that is, 28 days concrete age) in accordance with AS 1012.13 and the shrinkage shall not exceed 600 micro-strains.

### 6.3.5 Air Content

If an air entraining agent is used, the air content of the fresh concrete, determined by AS 1012.4.2 with compaction by interval vibration, shall be  $5.0 \pm 2.0\%$ .

### 6.3.6 Bleeding

Materials and mix design shall be such as to limit bleeding to prevent bleed water flowing over the slab edge during placement.

### 6.3.7 Restrictions on Chemical Content

The sulphate content of concrete as placed, expressed as the percentage by mass of acid-soluble  $\text{SO}_3$  to cement, shall not be greater than 5%.

The mass of acid-soluble chloride ion per unit volume of concrete as placed shall not exceed  $0.8 \text{ kg/m}^3$ .

Sulphate and chloride ion contents shall be determined by either of the following methods –

- a) Testing of concrete constituents in accordance with –
  - i) Chloride content – AS 1012.20 for aggregate and AS 1478.1 Appendix C for water and admixtures dissolved in water, thence calculating the total content and percentage; and
  - ii) Sulphate content – AS 1289.4.2.1 for water and admixture dissolved in water; AS 1012.20 for aggregates; AS 2350.2 for cementitious material, thence calculating the total content and percentage.
- b) Testing of individual constituents (except for admixtures) shall have been undertaken not more than 12 months prior to the date of closing of tenders. For admixtures, the soluble salt content may be taken as the value certified in writing by the manufacturer. The tested water shall be from the source proposed to be used in the Works; and
- c) Testing of hardened concrete in accordance with AS 1012.20. The concrete shall be produced using water only from the source proposed to be used in the Works.

## 6.4 Concrete Mixes

### 6.4.1 General

Production lean mix concrete shall not be delivered to the Works until written acceptance of the proposed job mix has been obtained from the Administrator [**refer Hold Point 1**].

### 6.4.2 Concrete Mix design and Testing

The Contractor shall be responsible for the design and production of all concrete used in the Works. The supply of concrete by a subcontractor or the use of pre-mixed concrete shall in no way lessen or remove this responsibility.

The testing required under this Clause shall have been carried out within the twelve-month period prior to the date of submission to the Administrator. The Administrator may permit a reduced trial if production mix results (but no trial mix results) from within the past 12 months are available.

For each concrete mix, all phases of any particular test shall be carried out by a single laboratory with appropriate registration issued by the National Association of Testing Authorities (NATA). All constituent test reports shall also be NATA-endorsed.

### **6.4.3 Hierarchy of Concrete Mixes**

For all mixes, test specimens shall be homogenous and moulded from the same batch. For the purposes of this Technical Standard the development of the concrete mix(es) to be used in the Works involves the following phases:

#### **6.4.3.1 Trial Mix**

These are concrete mix(es) which are used to develop a concrete mix(es) which meets all the requirements for the class of concrete for this Technical Standard. The trial mix(es) can be separate from or the same as the proposed job mix.

#### **6.4.3.2 Proposed Job Mix**

A proposed job mix is a trial concrete mix which satisfies all the requirements of this Technical Standard and which has been submitted by the Contractor to the Administrator.

A separate report for each proposed job mix, certifying conformance to the requirements of this Technical Standard and providing details required under Clause 6.4.4 below, shall be submitted by the Contractor not less than five working days prior to the commencement of paving. **Milestone**

#### **6.4.3.3 Job Mix**

Provided the submitted proposed job mix(es) meets all the requirements of this Technical Standard, the Administrator shall deem the job mix(es) suitable for incorporation into Works **Hold Point 1**. These mix(es) shall be called Job Mix(es), and the Administrator shall release Hold Point 1.

The job mix(es) for a particular class of concrete works shall be used on that class of concrete works only if –

- a) all the constituent materials comply with these Technical Standards and are the same as the materials used in the original proposed job mix design; and
- b) the specified requirements for the concrete are achieved in the Works, particularly strength and consistency.

#### **6.4.3.4 Nominated Job Mix**

This is the job mix nominated by the Contractor for use on a particular class of concrete works for a specific period. Each nominated job mix shall be a job mix which has been released under Hold Point 1.

Before commencing production of each sub-base concrete mix, the Contractor shall submit to the Administrator the nominated job mix, identifiable by its reference number that shall be used on a particular class of concrete work. This statement, signed by the Contractor, shall also state that the nominated job mix(es) and its constituents meet the requirements of this Technical Standard.

A nominated job mix shall not be changed without one day's notice to the Administrator.

For any class of concrete work there shall be only one nominated job mix at any specific time.

The Administrator will deem the job mix(es) suitable for incorporation into Works. **Hold Point 2**

### **6.4.4 Submission of Proposed Job Concrete Mixes**

Submission of a proposed job mix by the Contractor shall include the following details incorporating, where necessary, provision of NATA-endorsed test results for all tests (except for Vebe) in this Technical Standard and a copy of the Contractor's verification checklist –

- a) Class of concrete work – (structural pavement, slab anchors, non-integral shoulders, CRC, etc.);

- b) The name of concrete subcontractor or supplier, where applicable, and the proposed methods and degree of quality control. Where the contractor, subcontractor or supplier produces concrete of requisite classes on a regular basis, information is required regarding mean strength and standard deviation for recent output of each class of concrete to be supplied;
- c) Material constituents including: cement type, brand and source; fly ash source; water source;
- d) Admixture including source, type, name and dosage recommended by the manufacturer;
- e) Details of aggregates including source, geological type, moisture condition on which the mix design is based (i.e. oven dry, saturated surface-dry or nominated moisture content);
- f) All material test results including Test Method Q458 where applicable (see Clause 6.1.8.5);
- g) Contents by mass of yielded  $m^3$  of all materials comprising the mix, including aggregates, water, admixtures, cementitious materials (Portland cement and/or fly ash and/or slag), nominated slump, nominated grading and water/cementitious ratio;
- h) The proposed sequence of addition of ingredients. (For admixtures, details of pre-dilution shall be provided, consistent with the requirements of Clause 6.5.5.) Trial mixing shall comply strictly with these proposals; and
- i) Mix details and test results of a proposed job mix batch at the nominated slump with a tolerance of  $\pm 10$  mm for –
  - i) cement, fly ash and total cementitious content per yielded cubic metre of concrete;
  - ii) nominated grading of aggregates;
  - iii) compressive strength at age 7 days;
  - iv) compressive strength at age 28 days;
  - v) indirect tensile strength at age 28 days (on 150 mm cylinders);
  - vi) Vebe reading at nominated slump ( $\pm 10$  mm) for machine paving;
  - vii) drying shrinkage after 21 days air drying;
  - viii) air content;
  - ix) bleeding; and
  - x) chemical content in terms of Clause 6.3.7

The required testing shall have been carried out within the twelve-month period prior to the date of submission to the Administrator for assessment. All specimens shall be moulded from the same homogeneous batch.

#### **6.4.5 Variations to the Job Mix**

The Contractor may vary the quantities of the constituents in any job mix to maintain the concrete standards and 'paveability' (without resubmitting a new nominated mix in accordance with Clause 6.4.3.4) as follows –

- a) The total cementitious material may be varied by  $+ 30 \text{ kg/m}^3$  or, provided that the 28-day compressive strength results are sufficiently high to indicate that the specified strength can still be achieved, by
- b)  $- 10 \text{ kg/m}^3$ . Both of these are subject to conformance to the requirements of Clause 6.3.1;
- c)  $\pm 5\%$  by mass of each other constituent including aggregates, except admixtures and water; and/or
- d) Admixture dosages in accordance with Clause 6.1.7.

The Contractor shall notify the Administrator of any variations to a job mix prior to commencing production with the varied quantities.

### **6.5 Production and Transport of Concrete**

#### **6.5.1 General**

The Contractor's production and transport of concrete shall be such as to –

- a) prevent segregation and/or loss of materials;

- b) supply a homogenous product; and
- c) result in concrete workability, at the time of incorporation, which is compatible with the capacity of the placing equipment to achieve the specified compaction and surface finish with the minimum of manual finishing.

For mechanical paving, the mixing, agitation and transport equipment shall have an operational capacity which allows continuous paving at the Contractor's target paving speed. In no case shall the capacity be less than that required to maintain a continuous paving speed of 1 m per minute with adequate allowance for mixer efficiency and control testing.

Details of the proposed methods of handling, storing and batching materials for concrete and details of proposed mixers and methods of agitation, mixing and transport shall be submitted as part of the Quality Plan.

### **6.5.2 Handling, Storage and Batching of Materials**

Handling, storing and batching of materials for concrete shall comply with AS 1379 as amended by this Technical Standard.

Cementitious materials shall be weighed in an individual hopper.

Aggregates which have become intermixed or contaminated with foreign matter shall not be used in the Works.

Water and admixtures may be batched by weight or by volume. Volumetric batching of water shall employ the use of a measuring device calibrated in 1 litre increments. Measuring devices or dispensers for admixtures shall be calibrated to AS 1379.

### **6.5.3 Mixers and Agitation Equipment**

Concrete shall be mixed in a batch mixer having a capacity suitable for the type and extent of work being undertaken. Under no circumstances shall the rated capacity of the mixer be exceeded.

Mixers and agitation methods shall comply with AS 1379 Sections 3 and 4, varied in accordance with Clause 6.5.4. The minimum or recommended mixing time so determined shall therefore be adopted as the minimum mixing time for that mix.

### **6.5.4 Mixing**

#### **6.5.4.1 Mixer Uniformity Testing – General**

Mixing shall comply with AS 1379, Sections 3 and 4 and Appendix A, together with the requirements in Clause 6.5.4.

A mixer uniformity test shall be carried out for each type of concrete mix to be used in the Works. Alternatively, the Contractor may nominate to carry out a mixer uniformity test for only the base concrete and use the same mixing time for all other concrete mixes.

For the purpose of conducting the mixer uniformity test, the mixer shall be charged in accordance with the manufacturer's instructions and to the maximum volume (or throughput) proposed to be used for the Works. The volume (or throughput) at test shall not thereafter be exceeded unless a further uniformity test is conducted.

Concrete shall not be incorporated into the sub-base layer until the Contractor has demonstrated to the Administrator that the mixing procedures to be used for the Works and the resultant mix uniformity meet the criteria specified in Clause 6.5.4 hereunder. **Hold Point 2**

#### **6.5.4.2 Uniformity Testing of Central Concrete Mixers**

Where concrete is to be produced and mixed by a central concrete mixer, mixer uniformity tests shall be conducted before production paving is commenced with that mix, and thereafter upon production of each 30,000 m<sup>3</sup> of concrete from that mixer, or as otherwise required in accordance with AS 1379 Clause 3.4.2. Mixes of all types (including sub-base, base, gutters and kerbs) and for all clients shall be included in the above volumetric total.

Tests shall be carried out on each sub-base mix to be placed in the Works. Alternatively, tests may be carried out on the sub-base mix of lowest target slump to be placed in the Works, and the minimum mixing time so determined shall thereafter be adopted for all sub-base mixes.

Tests shall be conducted on three consecutive batches (of the same mix) which conform to all of the requirements of this Technical Standard.

The Contractor shall report mixing speed and mixing time.

The whole of a single batch shall be discharged and sampled by one of the following procedures –

- a) By discharge into a moving vehicle whose tray length is not less than 8 m. Sampling shall be from the truck prior to tipping. Samples shall be obtained using a shovel or scoop but the top 100 mm of concrete shall be excluded; or
- b) By discharge into a transport vehicle typical of that to be used in the Works, and then spread evenly over a length of between 6 and 10 m of prepared surface which is either sealed or pre-dampened to prevent absorption of water from the mix. Samples shall be taken from the deposited concrete in accordance with AS 1012.1.

In each case, the batch shall be sampled at three points approximately 15%, 50% and 85% along the discharged length of the mix. A sample of approximately 50 litres shall be taken from each point. Samples shall be individual and not composites (see AS 1012.1 Clause 3).

The mixer shall be deemed to have passed the uniformity test if the difference between the highest and the lowest values for the corresponding properties of the three samples does not exceed the limiting values given in AS 1379 Table A1 for any of the three batches. Additionally, no slump value shall lie outside the specified range.

#### **6.5.4.3 Uniformity Testing of Mobile Concrete Mixers**

Where concrete is to be mixed by mobile batch mixers, each mixer shall have been tested for uniformity within the past 24 months in accordance with AS 1379 and each mixer shall display identification plates or equivalent certification in accordance with AS 1379 Clause 3.4.1(d). Additional to the requirements contained therein, the date of latest test shall be shown.

Further tests shall be carried out upon evidence of inadequate mixing, as required under AS 1379 Clause 4.2.2.3.

#### **6.5.5 Charging the Mixer**

The method of charging the mixer shall be stipulated by the Contractor in the Quality Plan for the Works. Where appropriate, the method of charging the mixer shall be consistent with the recommendations of the supplier of the mix additive.

Admixtures shall be separately and thoroughly pre-diluted and mixed prior to their introduction to other materials and their injection into the water supply line. Their incorporation shall be in accordance with the instructions of the admixture manufacturer and, notwithstanding the above, shall be by a method which ensures that no adverse interaction occurs.

Mixing shall continue until the materials are thoroughly blended and the minimum mixing time has elapsed from the time when all the materials have entered the mixer.

The first batch of materials charged into a clean mixer shall contain sufficient excess cement, water and sand to allow 'coating' of the inside of the drum without diminishing the normal mortar content of the mix.

The entire batch of concrete shall be discharged from the mixer before any further charging of the mixer takes place.

If the mixing operation ceases for a period of time exceeding 45 minutes, the mixer shall be thoroughly cleaned out before subsequent batches are mixed.

#### **6.5.6 Retempering**

Concrete which is delivered by other than mobile batch mixer shall not have water or any other ingredient added to the mixed batch.

Concrete which is delivered by mobile batch mixer may be retempered strictly in accordance with the following conditions which shall replace the relevant corresponding Clauses of AS 1379.

Only the Contractor who is mixing the concrete may retemper a batch prior to the completion of discharge of the batch, and only if the relevant following conditions are satisfied –

- a) Immediately after retempering, the mixing mechanism shall be operated at mixing speed for such additional time as may be necessary to re-establish uniformity of the mix but not less than 90 seconds;
- b) The fact that a batch has been retempered and the quantity of water so added (accurate to one litre) shall be recorded on the identification certificate for that batch. If water is added after the commencement of discharge the remaining quantity of concrete at that time shall also be recorded;
- c) Immediately after Sub-Clause (a) above has been satisfied, the slump shall be determined and the requirements of Clause 6.3.3 'Consistence' shall apply;
- d) If a maximum water-to-cement ratio has been specified, the quantity of water added shall be such that the specified ratio is not exceeded;
- e) Retempering shall be permitted only within the times given in Table 6.5.6, calculating for each range of concrete temperatures the maximum time from the completion of batching to when retempering is to occur;

**Table 6.5.6 – Retempering Times**

Concrete Temperature <sup>1</sup>	Maximum Time between Batching and Retempering
≤ 15°C:	40 minutes
> 15°C to ≤ 25°C:	30 minutes
> 25°C:	20 minutes

Note 1 – Concrete temperature shall be measured at the commencement of discharge of a batch at intervals not exceeding 60 minutes throughout the paving operation. The latest value shall apply.

- f) Retempering shall take place only in the presence of the concrete mixing Contractor's representative previously nominated to the Administrator for this purpose, and only at either the concrete mixer, the testing station, or the point of placement; and
- g) Cylinders shall be made from the retempered mix to determine the compressive strength. Concrete which does not comply with this Clause shall not be incorporated into the Works.

The Contractor's Quality Plan shall detail how concrete supply will be monitored for conformance to this Clause and shall propose Corrective Action for nonconformance.

**6.5.7 Mixing Time Limits**

For mobile concrete mixers the minimum mixing time shall be the minimum mixing time determined in Clause 6.5.4.3.

For central concrete mixers, the minimum mixing time shall be the greater of the values determined from Table 6.5.7.

**Table 6.5.7 – Mixing Time Limits**

Concrete Batch Size	Minimum Mixing Time
All batches	The minimum mixing time determined in accordance with Clause 6.5.4.2.
For batches of 1.0 m <sup>3</sup> capacity or less	60 seconds
For batches exceeding 1.0 m <sup>3</sup>	60 seconds, plus 6 seconds for each cubic metre or fraction thereof in excess of 1.0 m <sup>3</sup> .
For twin shaft mixers	60 seconds after fully charging provided mixer uniformity requirements are met

Where, by reason of delay, it is necessary to hold a batch in the mixer, mixing may be continued for a maximum of 10 minutes except for split drum mixers where the maximum shall be 5 minutes. For longer delays, the batch may be held in the mixer and turned over at regular intervals, subject to the time limits on the forming time.

### 6.5.8 Maximum Forming Time

The Contractor shall determine a 'maximum forming time' for each nominated mix, taking into account the prevailing weather conditions and concrete temperature and the requirements of Clause 9.3.7. The procedure to determine the 'maximum forming time' shall be included in the Quality Plan. The nominated forming time shall not exceed 90 minutes for agitator-delivered concrete, and 60 minutes for tipper-delivered concrete.

Due consideration shall be given to the capacity of the equipment and methods in current use to place, compact and finish the mix to the specified standard with a minimum of manual finishing.

During paving, the Contractor shall continue to monitor and record the forming time, and shall report to the Administrator the actual forming time for those batches where it exceeds the nominated maximum forming time.

Batches with a forming time above nominated maximum forming times shall be conforming only if, after securing and testing in accordance with Clause 12, the compressive strength of cores from those specific batches conforms. This testing shall be additional to routine random sampling unless those batches had been chosen in the random selection process.

### 6.5.9 Transport and Delivery

A Manufacturer's Certificate in the form of a delivery docket in accordance with AS 1379 shall be supplied for each batch or load and shall be retained by the Contractor. The certificates shall be pre-numbered and issued sequentially in accordance with the order of batching. The certificates shall record the time of 'completion of batching' as defined in Clause 4. Any subsequent addition of water shall be in accordance with Clause 6.5.6. Such certificates shall be available to the Administrator on request.

The production and delivery of ready-mixed concrete shall be in accordance with the requirements of AS 1379, except as otherwise specified.

Freshly mixed concrete which is to be machine placed may be transported in tipper trucks, truck mixers or agitators. Except where otherwise permitted by the Administrator, truck mixers shall be used only as agitators. Only agitator vehicles shall be used to deliver concrete which will be hand placed.

The size of the batch in an agitator vehicle shall not exceed the manufacturer's rated capacity nor shall it exceed 80% of the gross volume of the drum of the mixer.

The mixed material shall be transported and delivered so that segregation and/or loss of the constituent materials do not occur. The deliveries shall be timed so as to ensure an essentially continuous placing operation.

The number of delivery vehicles provided shall be sufficient to ensure a constant supply of concrete to enable the paving plant to proceed continuously. For mechanical (slipform) paving, sufficient transport capacity shall be provided to enable continuous paving at the Contractor's target paving speed. In no case shall the capacity be less than that required to maintain a continuous paving speed of 1 m per minute.

## 7 CONFORMANCE TESTING OF CONCRETE PRODUCTION AND SUPPLY

### 7.1 General

The process requirements shall be checked for conformance with the specified requirements during and after the construction operation, as relevant. Conformance checking shall be carried out in accordance with any maximum lot sizes, minimum testing frequencies and minimum test numbers as given in Clause 16.

The Contractor is responsible for carrying out sufficient testing to ensure that the material complies with the standards and requirements of this Technical Standard. The testing frequencies and numbers of tests shall not be less than those given in Clause 16.

The Contractor shall arrange for a laboratory with appropriate NATA registration to conduct all sampling and testing of concrete and aggregates during production and supply, as required herein.

### 7.2 Aggregates

All aggregates shall be sampled in accordance with AS 1141.3.1 during concrete production.

Aggregates shall be tested for the properties in Clause 6.1.8 and the grading as per Clause 6.3 and shall be determined on samples of aggregates obtained at the concrete mixer.

Samples for conformance testing shall be randomly sampled from the stockpile lot.

**7.3 Air Content**

For each lot, air content measurement shall be carried out on all air-entrained concrete prior to placement. Testing shall be carried out in accordance with AS 1012.4.2. Concurrently, the mass per unit volume of the freshly mixed concrete shall be determined in accordance with AS 1012.5.

Testing shall be carried out on production days at the following frequency –

- a) one per load until three conforming results are obtained; and thereafter
- b) one per 100 m<sup>3</sup> until four consecutive conforming results are obtained; and thereafter
- c) one per 200 m<sup>3</sup> for the remainder of the day.

If a nonconforming result is obtained at any stage of testing, the frequency shall revert to (a).

For any sample, if the measured air content is not within the limits specified, one repeat test shall be made immediately from another portion of the same sample.

If the value obtained from the repeat test falls within the specified limits, the concrete represented by the sample shall be deemed to comply with the specified limits.

If the value obtained from the repeat test falls outside the specified limits, the testing frequency shall revert to that specified in sub-Clause (a) above.

Air entrained concrete with an air content higher than 7% shall be deemed to be non-conforming and shall not be used in the sub-base.

Air entrained concrete with an air content of less than 3% shall be deemed to be non-conforming. However, such concrete may be incorporated into the Works and acceptance of that load shall be conditional on the conformance for compressive strength of cores from the specific load which are to be secured and tested in accordance with Clause 12.2. This testing shall be in addition to routine random sampling, unless that particular load has been chosen in the random selection process.

**7.4 Consistence**

The slump shall be within ± 10 mm of the Contractor's nominated slump for the mix for mechanically placed concrete and within ± 15 mm thereof for hand-placed concrete.

The consistence of the concrete shall be checked by means of the slump test in accordance with AS 1012.3.1. Sampling shall be as follows –

- a) For tipper truck delivery: the test sample shall be obtained prior to discharge using a shovel or scoop. The top 100 mm shall be excluded; or
- b) For agitator delivery: the test sample shall be an individual sample (i.e. not composite) obtained in accordance with AS 1012.1.

The consistence shall be tested within the time limits specified in Table 7.4-A as measured from completion of batching and as appropriate for the temperature of concrete.

**Table 7.4-A – Consistence Time Limits**

Temperature	Maximum Time
≤ 15°C	40 minutes
> 15°C to ≤ 25°C	30 minutes
> 25°C	20 minutes

Concrete temperatures shall be measured at the commencement of discharge of a batch at intervals not exceeding 60 minutes throughout the paving operation. The latest value shall apply.

Slump testing shall be carried out as given in Table 7.4-B.

**Table 7.4-B – Consistence (Slump) Testing Requirements**

Event	Activity
-------	----------

Commencement of slump testing on each class of work	Test every load prior to discharge until 8 consecutive conforming loads are tested. Calculate the standard deviation (SD) of test results from these 8 loads.
If SD > 8.0 mm	Continue slumping every load until test results from any 8 consecutive loads have a SD < 8.0 mm.
If SD ≤ 8.0 mm	Go to process slump testing. Process slump testing involves slump testing every fourth load until a nonconforming slump is measured.
If a nonconformance occurs	Following a nonconformance, all loads thereafter shall be slump tested (prior to discharge) until the SD of test results from 6 consecutive loads is less than or equal to 8.0 mm. When this occurs, slump testing may revert to process slump testing each fourth load.

Additional consistence testing shall also be conducted as required in accordance with Clause 6.5.6.

If, for any sample, the measured slump is not within the specified limits, one repeat test shall be made immediately from another portion of the same sample. If the value obtained from the repeat test falls within the specified limits, the concrete represented by the sample shall be deemed to comply with the appropriate specified value; otherwise it shall be deemed nonconforming.

Concrete which is nonconforming in relation to consistence shall not be incorporated into the sub-base but may be used elsewhere in the Works, subject to the concrete complying with the Technical Standard for the particular application.

All slump test results shall be recorded, whether conforming or otherwise.

## 8 CONSTRUCTION OF SUBGRADE BEAMS

### 8.1 General

Subgrade beams shall be provided below the sub-base at the locations as shown on the Drawings. They shall extend the full length of joints unless indicated otherwise on the Drawings, and shall be constructed prior to placing the sub-base.

### 8.2 Excavation

Excavation for subgrade beams shall be to the dimensions shown on the Drawings.

All loose material shall be removed and the vertical faces trimmed to neat lines. The bottom of the trench shall be recompacted, where required, to the density of the adjacent undisturbed material.

Excavated material shall be disposed of as indicated in the documents or, if not indicated, at a location and manner proposed by the Contractor and approved by the Administrator.

### 8.3 Concrete

Concrete supplied for subgrade beams shall comply with the Technical Standard for concrete base or alternatively shall be normal class concrete with strength grade N32E7 in accordance with AS 1379, 20 mm maximum nominal size of aggregate and 80 mm slump at the point of placement.

The concrete shall be mixed and delivered in accordance with AS 1379 as amended by Clause 6.5.

The compressive strength shall be determined at seven days in accordance with AS 1012.9 for one specimen of concrete per subgrade beam pour and shall not be less than 20.0 MPa.

### 8.4 Steel Reinforcement

Steel reinforcement shall be the type and size shown on the Drawings and shall be supplied and installed in accordance with MRTS40 *Concrete Base in Pavements*.

The placement of reinforcement shall constitute **Hold Point 3**.

### 8.5 Placement of Concrete

Concrete shall be placed and compacted in accordance with this Technical Standard.

A steel float shall be used to produce a smooth surface finish, free of any texture.

The top of the subgrade beam shall be level with the top of the subgrade. Any loose subgrade material shall be removed or recompacted to the correct level.

### 8.6 Protection

The subgrade beams shall be protected from damage by plant, motor vehicles and the paving operation. Any damage shall be made good by the Contractor.

### 8.7 Curing

The top surface beam shall be cured in accordance with Clause 9.5 before placing the sub-base.

Vehicular traffic shall not be allowed on the beam until the achievement of an in-situ strength of 20.0 MPa.

## 9 PAVING CONCRETE IN SUB-BASE

### 9.1 Curing Compounds

The sub-base shall be cured by the application of sprayed curing compound. The compound shall be applied immediately after the surface is free of bleed water so as to form a continuous and unbroken film.

The Contractor shall supply for each consignment of curing compound a copy of the delivery docket stating the manufacturer's name and the type and quantity delivered, together with the certificates as specified in Clause 9.1.2.

Batches of curing compound shall be used in order of receipt and shall be stored in waterproof conditions. The Contractor shall comply with any special requirements of the manufacturer of the product. Any curing compound which does not conform to the Technical Standard requirements immediately before use is nonconforming and shall be removed from the site and replaced.

#### 9.1.1 Types of Curing Compounds

The curing compound for sub-base shall comply with the requirements of Table 9.1.1.

**Table 9.1.1 – Curing Compound for Sub-base**

Type of Base	De-bonding or Protection Treatment Specified	Required Curing Compounds for Sub-base
Jointed Unreinforced Concrete	bitumen seal	wax emulsion
Jointed Reinforced Concrete	wax emulsion	wax emulsion, hydrocarbon resin, water-borne hydrocarbon resin, or styrene butadiene resin (SBR)
Continuously Reinforced Concrete	wax emulsion	wax emulsion
Steel Fibre Reinforced Concrete	wax emulsion	wax emulsion
Asphalt	bitumen seal	hydrocarbon resin, or water-borne hydrocarbon resin

#### 9.1.2 Technical Standard for Curing Compounds

For each curing compound proposed for use in the Works, the Contractor shall provide to the Administrator a report, supported by test certificates from a laboratory with appropriate NATA registration, to certify that the proposed curing compound has been tested and that it complies with the Technical Standard. The sample for acceptance testing which is covered by the Contractor's report shall hereafter be referred to as the 'reference sample'. A single reference sample may be used on more than one project.

Curing compounds shall comply with the standards in Table 9.1.2.

**Table 9.1.2 – Standards for Curing Compounds**

Type	Standard
Wax emulsion	MRTS42 <i>Supply of Wax Emulsion Curing Compound for Concrete</i>
Hydrocarbon resin	AS 3799 Class B, Type 2
Water-borne hydrocarbon resin	AS 3700 Class Z, Type 1-D or Type 2
Styrene butadiene resin (SBR)	AS 3700 Class Z, Type 1-D or Type 2

The test certificates for the requirements of Table 9.1.2 shall report also the non-volatile content, the efficiency index and the density and shall (except for bitumen emulsion) provide a reference for the infrared spectrum, as determined in accordance with Test Method Q630.

The Contractor shall provide written certification that each delivered batch has the same formulation as that of the reference sample. The certification shall be supported by uniformity testing on both non-volatile content and density in accordance with AS 3799 Clause 3.2, and on viscosity in accordance with Clause 3.1.5. Additionally, an infrared spectrum shall be provided (except for bitumen emulsion) and shall match that of the reference sample.

Bitumen used for protection shall comply with MRTS17 *Bitumen*.

### 9.1.3 Conformance of Compounds

All testing shall be undertaken by a laboratory with appropriate NATA registration.

#### a) Initial delivery

A random sample shall be taken from the first delivery to the project, and tested in accordance with AS 3799 for the following properties –

- i) non-volatile content;
- ii) density;
- iii) drying time; and
- iv) infrared spectrum as determined in accordance with Test Method Q630.

On the basis of these results, the Contractor shall provide written certification (accompanied by the test results) that the delivered batch has the same formulation as that of the reference sample; and

#### b) Subsequent deliveries

For all subsequent deliveries, the Contractor shall provide written certification that each delivered batch has the same formulation as that of the initial delivery. The certification shall be made, on the basis of the manufacturer's Certificate of Analysis, for uniformity of the following properties –

- i) non-volatile content;
- ii) density; and
- iii) viscosity.

### 9.1.4 Supply and Storage

The Contractor shall supply, for each consignment of curing compound, a copy of the invoice stating the manufacturer's name and the type and quantity delivered, together with the manufacturer's certificates as required in Clause 9.1.3.

Batches of curing compound shall be used in order of receipt and shall be stored in waterproof conditions. The Contractor shall comply with any special requirements of the manufacturer of the product. Any curing compound which has become stale or unsuitable shall be removed from the site and replaced at the Contractor's expense.

## 9.2 Mechanical Paver

The mechanical paver shall be a self-propelled machine with a gross operating mass of not less than four tonnes per linear metre of paved width. It shall be capable of paving at a speed of one metre per minute or less as required to enable the continuous operation of the paver and obtain the required degree of compaction. It shall include the following features –

- a) an automatic control system with a sensing device to control line and level to the specified tolerances;
- b) a means of regulating the flow of mix to the vibrators without segregation of the components;
- c) internal vibrators capable of compacting the full depth of the concrete;
- d) an adjustable extrusion screed and/or conforming plate to form the surface profile and produce the required finish on all surfaces; and
- e) the capability of paving in the widths and to the depths shown on the Drawings.

The paver shall be regularly inspected and serviced to ensure that it is maintained at all times in full operating condition consistent with the manufacturer's specifications. Key items such as vibrators and sensors shall be monitored throughout all paving lots. **Witness Point**

## 9.3 Placing Operations

### 9.3.1 General

Mechanical paving shall be used except where this is impracticable. Impracticable areas shall include tapers and other areas approved by the Administrator. The areas which are not constructed using a mechanical paver may be hand-placed within fixed forms which include the requirements of Clause 9.3.5.

The Contractor shall place and finish concrete so as to –

- a) limit segregation or loss of materials;
- b) limit premature stiffening;
- c) produce a uniform, dense, homogenous product between planned cracks, joints and edges;
- d) expel entrapped air; and
- e) provide the specified thickness and surface finish.

Details of the equipment and methods to be used for spreading, placing and finishing the concrete sub-base, together with proposed paving widths and any areas to be hand-placed shall be submitted as part of the Quality Plan.

For each of the proposed mechanical paving configurations, the following parameters shall be nominated –

- a) maximum paving speed (i.e. instantaneous, not average);
- b) target (optimum) paving speed;
- c) vibrator spacing, frequency and amplitude, and ranges thereof;
- d) gross operating mass per linear metre of paving width; and
- e) installation of guide-wire tracking location system.

The Contractor shall operate a system to indicate the malfunction of each individual vibrator and shall provide details of same.

For hand-paving, the following parameters shall be nominated –

- a) the size and number of vibrators; and
- b) the spacing and duration of vibrator insertions.

The Contractor shall give the Administrator seven days written notice of his intention to commence construction of the sub-base on any section of work (including placement of the trial concrete section).

### **Hold Point 4**

A trial length of concrete shall be constructed in accordance with Clause 9.7, prior to commencement of paving and also as required by the Administrator.

Subgrade beams shall be constructed at the locations shown on the Drawings and in accordance with Clause 8, prior to construction of the sub-base concrete.

During construction of the sub-base, the Contractor shall make provision to permit construction of base slab anchors at locations shown on the Drawings.

The Contractor shall maintain records showing the location of each batch/load of concrete in the finished work. The system shall be sufficiently accurate to enable subsequent identification of specific batches/loads for examination and/or testing. Details of the system shall be submitted as part of the Quality Plan.

### 9.3.2 Temperature and Rain

The Contractor shall measure and record concrete and air temperature in the shade at the point of placement. The air temperature shall be taken adjacent to the point of concrete placement but remote from artificial influences such as the paver.

No concrete shall be placed in the Works if –

- a) the temperature of the concrete is less than 10°C or exceeds 30°C;
- b) during rain or when rain is likely to fall during placement; or
- c) the ambient air temperature at the site of placement is less than 3°C and falling or greater than 36°C during placement. If the ambient air temperature measured at the point of placement is likely to exceed 36°C during placing and finishing operations, the Contractor shall take practical precautions, included in the Quality Plan, to ensure that the temperature of the concrete does not exceed the permitted maximum, otherwise it shall be deemed nonconforming. Typical precautions include those listed below –
  - i) At the mixer –
    1. shade or irrigate aggregate stockpiles;
    2. paint water tanks white;
    3. insulate or bury delivery lines; and/or
    4. chill the water.
  - ii) At the site –
    1. cool the formwork by dampening with water sprays;
    2. apply curing compound as early as possible;
    3. erect wind breaks; and/or
    4. minimise the time for placing and finishing.

Attention shall be paid to providing early curing for hot weather concreting operations.

### 9.3.3 Underlying Surface Conditions for Placement of Concrete

#### 9.3.3.1 General

The surface of the sealed substrate on which concrete sub-base is to be placed shall be clean and free of loose foreign matter. It shall be in a damp condition at the time of placement of sub-base. The surface shall not contain ponded water.

The height of the substrate shall be that measured on the top of the bitumen seal. The level at any point on the top of the substrate shall be within  $\pm 10$  mm of the specified height.

Any activity which disturbs the surface of the lean mix concrete sub-base, such as the installation of the detector loops into the concrete sub-base, shall be finished to conform to the geometric requirements of this Technical Standard for the top of the lean mix sub-base. If it is to be covered by a bitumen protection layer, an additional wax curing layer shall be placed over the disturbed area plus 200 mm extension on all sides prior to the bitumen being laid. If, however, a wax de-bonding layer is to be applied, an additional wax de-bonding treatment shall be applied over the disturbed area plus 200 mm extension on all sides.

Material placed in the lean mix concrete sub-base shall firmly adhere to the excavated slots in the concrete sub-base.

### 9.3.3.2 Survey at the Top of Substrate

Prior to setting out levels and commencing placement of sub-base, the Contractor shall determine the heights of the top of the substrate. Where the underlying layer is required to be spray sealed, levels shall be taken on the top of the seal and after removal of foreign and/or loose material such as excess aggregate.

The survey shall be carried out with a flat-based survey staff or ranging pole having a base area of not less than 300 mm<sup>2</sup> nor more than 400 mm<sup>2</sup>.

The surface levels shall be determined –

- a) at the centreline, midpoint of each trafficked lane and the outer edges of the proposed concrete pavement on cross-sections at longitudinal intervals of 22.5 m and at locations which are immediately beneath the survey locations on the surface of the lean-mix sub-base with allowance for the different longitudinal intervals; and
- b) at an additional 10 random locations per lot.

The Contractor shall submit to the Administrator a schedule of the measured heights at least four working days before programmed commencement of the sub-base paving in a given area. Paving of concrete sub-base shall not proceed unless the heights of the substrate are within tolerance. **Hold Point 5**

Heights shall be reported to the nearest millimetre.

### 9.3.4 Mechanical Paving

The supporting surface for the tracks of the paver, curing machine and any other equipment in the paving and curing train shall be brought to a smooth and firm condition (such that the deflection under the paver tracks is less than 2 mm) by the Contractor prior to paving and shall be maintained in such condition by the Contractor.

The mechanical paver shall spread, compact, screed and finish the freshly placed concrete in such a manner that a minimum of finishing by hand will be required. A homogeneous surface with uniform finish shall be provided in accordance with Clause 9.3.6.

The slab edge produced by the paver shall maintain its shape and shall have not more than 10% sagging or tearing. If excessive bleed-water flow occurs, such as flowing over the slab edge, the Contractor shall cease paving until the consistence of the mix is adjusted to prevent such flow, or until the mix is redesigned.

The Contractor shall co-ordinate the delivery, spreading and paving activities, taking into account the location of each batch of concrete in the Works and delay time so as to maintain the continuous and uniform progress of the paver.

Where an interruption to paving occurs which is likely to result in a non-homogeneous concrete mass, the Contractor shall form a transverse construction joint in accordance with Clause 10.1. The Contractor shall record details of any interruptions to the progress of the paver, including the reasons thereof, location, and duration.

At locations where the paver is unable to fully compact and finish the concrete (such as, but not confined to, transverse construction joints), supplementary manual vibration shall be used. The number of working internal vibrators used shall be not less than one for each 10 m<sup>3</sup> of concrete placed per hour, with a minimum total of two. The number of standby vibrators shall be not less than one quarter of the number in use, with a minimum of one.

Should subsequent testing at the location of an interruption indicate the presence of non-homogeneous concrete, such concrete shall be removed and replaced in accordance with Clause 14.

### 9.3.5 Hand-Placing

The Contractor shall program hand-placing operations to ensure that the riding quality of the finished pavement is not impaired.

Forms shall be designed and constructed so that they can be removed without damaging the concrete and shall be true to line and grade, and braced in a substantial and unyielding manner. Forms shall be mortar tight and de-bonded to ensure non-adhesion of concrete to the forms. They shall be set to tolerances equivalent to those specified for the finished sub-base surface.

Concrete shall be deposited and spread uniformly in the forms without segregation. The concrete shall be compacted by immersion vibrators and by at least two passes of a hand-guided vibratory screed traversing the full width of the slab on each pass. A suitable head of concrete shall be maintained in front of the screed over its whole length to ensure the uniform transmission of vibration into the slab.

The number of working internal vibrators in use during a concrete pour shall be not less than one for each 10 m<sup>3</sup> of concrete placed per hour, with a minimum total of two. The number of standby vibrators shall be not less than one quarter of the number in use, with a minimum of one.

The slab shall then be compacted and finished by at least two passes of a hand-guided vibratory screed traversing the full width of the slab on each pass. A suitable head of concrete shall be maintained in front of the screed over its whole length to ensure the uniform transmission of vibration into the slab.

A dense and homogeneous surface with uniform finish shall be provided, with a surface finish requiring a minimum of hand finishing in accordance with Clause 9.3.6.

Where an interruption to placing occurs which is likely to result in a non-monolithic concrete mass, the Contractor shall form a transverse construction joint in accordance with Clause 10.1.

Should subsequent testing at the location of an interruption indicate the presence of non-monolithic concrete, such concrete shall be removed and replaced in accordance with Clause 14.

### 9.3.6 Finishing Operations

All unformed surfaces shall be finished true to line and level within the tolerances specified in Clause 9.4.

All finishing operations shall be completed prior to the application of any curing. The finishing operation shall be such as to provide a non-voided homogeneous surface, free from visible surface cracking. Where possible, the concrete surface shall be reworked as necessary to eliminate plastic shrinkage cracking.

After paving, the sub-base surface shall have a smooth uniform finish except where the sub-base is to be covered by a sprayed bituminous seal (prior to placement of a concrete base), asphaltic concrete base or granular flexible base, when the surface may be textured with a hessian drag. The mean texture depth shall not be more than 0.6 mm when tested in accordance with Test Method Q705.

Where the sub-base will not have sprayed bituminous protection treatment and is to be covered by a concrete base, the smooth uniform finish shall have minimum dimpling and be free from ridges or recesses. Where wax emulsion de-bonding treatment is to be used, depressions greater than 1.5 mm from a 150 mm straight-edge shall be treated to achieve a smooth surface.

### 9.3.7 Prevention of Moisture Loss

The Contractor's Quality Plan shall identify which meteorological or other data will be collected, how such data will be used and what measures will be taken to restrict the evaporation of water from the concrete surface and prevent the incidence of plastic shrinkage cracking.

Figure 9.3.7 is provided as a guide for assessing the rate of evaporation.

Where necessary, the Contractor shall use an evaporation retarder to restrict the evaporation of water, in accordance with the manufacturer's instructions. Details of the proposed evaporation retarder shall be submitted to the Administrator at least one week before concrete work commences.

Should the Contractor elect to use an evaporation retarder to restrict the evaporation of water, application shall be by fine uniform spray. Evaporation retarder shall not be used as a finishing agent.

The Contractor shall regularly inspect the plastic concrete to monitor the effectiveness of his procedures and, where necessary, modify them to prevent the formation of plastic shrinkage cracking.

Figure 9.3.7 – Evaporation from Concrete Freshly Placed on Site

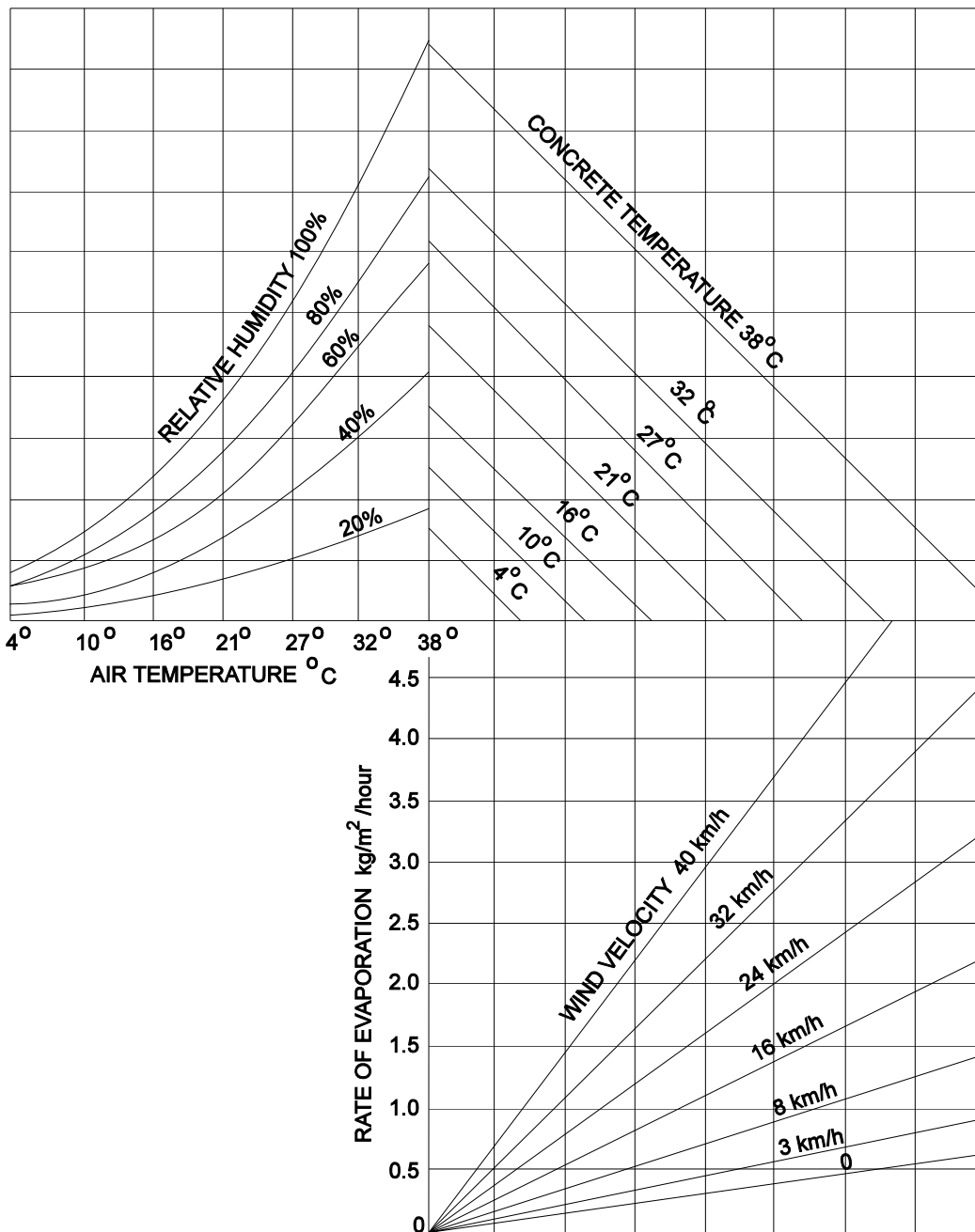

Figure 9.3.7 shows the combined effects of air temperature, humidity, concrete temperature and wind velocity on the rate of evaporation of water from freshly placed and unprotected concrete. For example, for an air temperature at 27°C, relative humidity at 40%, concrete temperature at 27°C and a wind velocity of 26 km/h the rate of evaporation would be 1.6 kg/m<sup>2</sup>/hour.

To determine the evaporation rate from the graph –

- enter the graph at the air temperature (in this case 27°C), and move vertically to intersect the curve for relative humidity encountered – here 40%;
- Move horizontally from this point to the respective line for concrete temperature – here 27°C; and
- Move vertically down to the respective wind velocity curve – in this case interpolating for 26 km per hour – and then horizontally to the left to intersect the scale for the rate of evaporation.

### 9.3.8 Placement of Base Concrete Prior to Achievement of Sub-Base Specified Strength

The Contractor may place the base on the lean mix sub-base upon achievement of an in-situ strength in the sub-base of 4 MPa on the following conditions –

- a) The sub-base shall be assessed for strength on the basis of the last cores taken from that lot prior to the placement of base, up to a maximum age of 42 days; and
- b) After the placement of base, no further strength testing of the sub-base shall be allowed.

All sub-base concrete which has not achieved 5.0 MPa within the specified 42-day period, including concrete covered by bitumen protection layer, shall be removed and replaced, unless accepted for utilisation for a reduced level of service in accordance with Clause 15.1.

No payment will be made for the nonconforming concrete or for any bitumen protection layer placed thereon.

## 9.4 Geometric Standards

### 9.4.1 Horizontal Alignment Tolerances

For the purpose of this Clause, an outer edge is classified as one against which material other than sub-base concrete (e.g. granular backfill, kerb concrete, no-fines concrete) is to be placed.

Where the overlying base is to be cementitious concrete of any type, the outer edges of the sub-base shall be constructed 50 mm wider than the plan position of the overlying base unless otherwise shown on the Drawings, within a tolerance of  $\pm 25$  mm.

The outer edges of the sub-base shall be constructed square to the finished top surface of the sub-base, within a tolerance of  $\pm 5^\circ$ .

Where the edge of the slab is to form a longitudinal construction joint with adjoining sub-base concrete, the horizontal alignment tolerances shall comply with Clause 10.2.

### 9.4.2 Surface Smoothness Including 3 m and 150 mm Straight-Edge Tolerances

The top surface of the sub-base shall be smooth and without depressions, holes, striations or protuberances.

The top surface of the sub-base shall not deviate from a 3 m straight-edge, laid in any direction, by more than 5 mm. Where the straight-edge is placed on convex sections, the cantilever length shall not exceed 0.75 m.

Where wax emulsion debonding treatment is to be under base concrete, depressions in the top surface of the sub-base shall not exceed 1.5 mm beneath a 150 mm straight-edge.

### 9.4.3 Surface Heights

Where the sub-base is covered by a bituminous seal protection layer, the specified height of the top surface of the sub-base as shown on the Drawings shall be decreased by the Average Least Dimension of the cover aggregate when tested in accordance with Test Method Q202.

The level at any point on the top of the sub-base shall be within  $\pm 10$  mm of the specified height as shown on the Drawings or the revised specified height determined above for areas covered by a bitumen seal protection layer.

### 9.4.4 Thickness

The arithmetic average thickness of each lot shall not be less than the thickness specified in the Drawings or the revised specified thickness which is the specified thickness less the thickness of the bituminous seal protection layer on areas where this is applied.

Where the arithmetic average thickness of sub-base is more than 10 mm below the specified or revised specified sub-base thickness, the sub-base shall be removed and replaced in accordance with Clause 14.

Where the arithmetic average thickness of sub-base is 10 mm or less below the specified sub-base thickness, the sub-base may be accepted at a reduced level of service in accordance with Clause 15.2.

### 9.4.5 Inspection

The Contractor shall survey the alignment and surface levels for nonconformance with the above requirements within 24 hours of placing an area of sub-base or as otherwise agreed with the Administrator. If a nonconformance is detected, the Contractor shall immediately implement Corrective Action.

### 9.4.6 Rectification

Individual locations identified as nonconforming in terms of finished surface profile shall be rectified to achieve conformance and provide a surface consistent with the adjacent conforming concrete.

## 9.5 Curing by Application of Liquid Membrane-Forming Compound

### 9.5.1 Method of Application

Curing shall be by use of liquid membrane-forming curing compounds which comply with the requirements of Clause 9.1.

The curing of unformed (exposed) surfaces of concrete shall commence as soon as the relevant finishing or texturing operations are complete and, in the case of water-based emulsions, within 15 minutes of the surface being free of bleed water, so as to form a continuous and unbroken film. **Witness Point**

The curing compound shall be applied immediately after the surface is free of bleed water, in a fine spray and by the following means –

- a) For paving widths < 2.5 m – by hand lance with either single or multiple nozzles;
- b) For paving widths  $\geq 2.5$  m < 4.5 m – by spray bar fitted with multiple nozzles spaced to give a uniform cover for the full paving width in a single pass; or
- c) For paving widths  $\geq 4.5$  m – by a mechanical sprayer fitted with a spray bar with multiple nozzles spaced to give a uniform cover for the full paving width in a single pass.

For areas where mechanical means of application are not used, the compound shall be sprayed by hand lance and the rate shall be increased by 25%. Included in this category are the faces of formed joints and sections of slipformed edges which are supported by temporary forms at the time of initial spraying.

Equipment and materials for curing operations shall be kept on site at all times during concrete paving.

All sprayers shall incorporate a device for continuous agitation and mixing of the compound in its container during spraying. After shutting off the spray nozzles there shall be no dripping of the curing compound on the concrete surface.

Spray bars and lances shall be fitted with protective hoods to minimise the drift of curing compounds to workers and roadside areas.

If the mechanical sprayer becomes unavailable, concrete paving by mechanical means shall cease, and shall not recommence until the mechanical sprayer becomes fully operable again.

Edges shall receive a second application with a hand lance at the specified rate.

### 9.5.2 Rate of Application

The curing compound shall be applied at a rate not less than the rate necessary to allow for absorption, run off, variation in the application and other losses. It shall leave a residual film which represents an application not less than that stated on the Certificate of Conformance for wax emulsion in accordance with MRTS42 *Supply of Wax Emulsion Curing Compound for Concrete* or, for other compounds, the application rate used in the Moisture Retention Performance test in Clause 3.1.2 of AS 3799.

For the sides of slabs and for areas less than 2.5 m width where a spray bar is not used, the compound shall be sprayed by hand lance and the rate shall increase by 25%.

Any element of a lot on which the application does not conform to the requirements of this Technical Standard shall be resprayed within six hours at an application rate not less than twice the deficiency in the original application.

### 9.5.3 Integrity of Membrane

The curing membrane shall be maintained in a continuous and unbroken film for seven days after placing the concrete. Any damage to the curing membrane shall be made good by hand spraying of the affected areas.

Additionally, at the commencement of each paving run (and notwithstanding that film damage may not be readily apparent), any adjoining hardened concrete of age less than seven days shall be resprayed with a single application for a minimum distance of 7 m in the area trafficked by staff during placement at the construction joint.

## 9.6 Protection of Work

### 9.6.1 Weather Protection

The Contractor shall undertake continuous surface temperature monitoring during the first 24 hours after placement. The temperature shall be monitored at not fewer than two locations within each day's paving, using purpose-made surface thermometers and in such a way as to reflect the true surface temperature.

The Contractor shall ensure that the temperature of the concrete does not fall below 5°C during the first 24 hours after placing. Details of procedures and equipment proposed to be used for the protection of recently placed sections, in the event of low air temperatures, shall be submitted as part of the Quality Plan. Failure to maintain the temperature of the concrete at or above 5°C shall constitute a nonconformance under the Contract.

The Contractor shall protect the work from rain damage. Detailed proposals for procedures and equipment to be used for such protection shall be submitted as part of the Quality Plan.

The equipment for protection of work shall be kept on site and be capable of being fully operational at short notice. Personnel experienced in the operation of such equipment shall be available at short notice.

### 9.6.2 Trafficking of Subbase Concrete

The sub-base shall not be trafficked by either personnel or construction equipment other than those associated with testing, utilising vehicles less than 2.0 tonnes, for at least 10 days or, alternatively, until the in-situ concrete compressive strength determined in accordance with AS 1012.14 is not less than 4.0 MPa. Thereafter, while access by personnel shall be acceptable, only that construction equipment necessary for the following operations shall be permitted to traffic the sub-base:

- a) Application of the de-bonding interlayer, protection layer and spall treatment; or
- b) Paving of concrete base and then only for a distance of up to 300 m immediately ahead of the paver, except for the purpose of fixing steel or as otherwise specifically provided elsewhere in the Technical Standard. All vehicles other than the concrete paving machine and the tyning machine shall comply with the current Queensland Mass Limits for Heavy Vehicles.

Notwithstanding the above, any damage caused to the sub-base as a result of the Contractor's operations shall be rectified to produce a dense, homogeneous sub-base with the specified surface finish. **Hold Point 6**

## 9.7 Trial Lengths

At least seven days before the start of the sub-base concrete work, a trial length of at least 50 m but not more than 500 m shall be laid for mechanical paving construction; and a trial length of at least 15 m but not more than 500 m shall be laid for hand paving construction.

The trial length shall be laid to assess the suitability of the proposed materials, plant, equipment and construction methods to meet the requirements of this Technical Standard. Included in the matters which shall be assessed by the Administrator are the following –

- a) The capacity of the plant and equipment to deliver, spread and pave with continuous and uniform progress of the paver under a range of conditions; and
- b) The capacity of the paver (where applicable) to achieve the specified compaction and finish. The Contractor shall demonstrate this with the paver operating at the nominated maximum speed, and the vibrators at nominated spacing and frequency, as detailed in the Quality Plan.

The trial length shall be constructed at a similar rate to that which is proposed in the main Works. If the trial is conducted at a paving width of less than 70% of the maximum width proposed to be placed by that method in subsequent runs, the Administrator will have the right to call for a new trial section prior to the commencement of production paving at the maximum width.

At least 10 days prior to the construction of the trial length of sub-base, the Contractor shall submit as part of his Quality Plan for the Administrator's acceptance, a detailed description of the proposed materials, plant, equipment and construction methods **Milestone**. Paving operations shall not commence until the detailed description of proposed materials, plant, equipment and construction methods is accepted by the Administrator. **Hold Point 7**

No trials of new materials, plant, equipment or construction methods nor any development of them shall be permitted either during the construction of the trial length or in any subsequent paving work, unless they form part of further approved trials.

The trial length should be constructed in one continuous operation, not incorporating subgrade beams.

In the event of non-conformances in the trial section, the Administrator may require a new trial section which shall be treated as the first.

The Administrator may conduct testing of the trial sub-base at specific (i.e. non-random) locations to assess its conformance with the Technical Standard.

The Administrator will have the right to call for a new trial section at any stage of work under the Contract when changes by the Contractor in the equipment, materials, mix, plant or rate of paving are deemed by the Administrator to be significant and warrant such a procedure or when concrete sub-base does not comply with the Technical Standard.

The acceptance of a trial section for incorporation into the Works shall be conditional on its conformance with the Technical Standard. **Hold Point 8**

## **9.8 Concrete Sub-base Cracking**

The Contractor shall detail in the Quality Plan the inspection schedule for cracking in the sub-base.

### **9.8.1 Typical Sub-base Cracking**

Lean-mix concrete sub-base shall typically form full-depth transverse cracks continuous for the full width of the paving run at approximately 5 – 15 m intervals. In sub-base placed in a single pass more than 7 m wide, longitudinal full-depth cracks may also typically occur at spacings of approximately 5 m and in continuous lengths exceeding 5 m. Cracking of this type shall not be deemed to be nonconforming unless subsequent deterioration occurs prior to its being covered with base.

### **9.8.2 Plastic Shrinkage Cracks**

There shall be no plastic shrinkage cracking. Slabs with minor plastic shrinkage cracking may be accepted, subject to utilisation of a non-conforming lot for a reduced level of service.

### **9.8.3 Additional Longitudinal and Transverse Cracks**

Any cracking beyond that specified above shall render the concrete sub-base non-conforming. The Contractor shall immediately implement Corrective Action.

Damaged areas of sub-base concrete (such that the sub-base concrete is outside the specified tolerances) shall be repaired or replaced.

## **10 CONCRETE PAVEMENT JOINTS**

### **10.1 Transverse Construction Joints**

Transverse construction joints shall be provided only at discontinuities in the placement of concrete determined by the Contractor's paving operations. They shall not be corrugated and they need not be scabbled unless otherwise shown on the Drawings.

The Contractor shall develop a written procedure as part of his Quality Plans for the construction of transverse construction joints. It shall include the provision of a stop-end ('head-board') levelled to the surface profile.

Transverse construction joints shall be constructed at an alignment normal to the adjacent longitudinal joints with a tolerance of  $\pm 5^\circ$  (1 in 10). They shall be constructed square to the finished top surface of the sub-base with a tolerance of  $\pm 5^\circ$  (1 in 10).

The joint shall be continuous over the paving width and shall not have steps or offsets in any axis. The line of transverse construction joints shall not deviate from a 3 m straight-edge placed along the joint by more than 20 mm, nor from a 3 m straight-edge placed across the joint by more than 10 mm.

The top surface of transverse construction joints shall not deviate from a 3 m straight-edge placed along the joint by more than 3 mm.

The Contractor shall inspect each joint within 24 hours of its construction. Where the first-placed face of a joint is nonconforming or the edge is damaged, it shall be reinstated or repaired prior to the placement of the adjacent concrete and shall not be placed integrally with the adjacent concrete.

### **10.2 Longitudinal Construction Joints**

Longitudinal construction joints shall be formed only within the zone  $0.25 \pm 0.15$  m from the nominated plan location of longitudinal joints in the base, unless otherwise shown in the Drawings.

Where a crown exists in the base, the longitudinal construction joint in the sub-base shall be constructed within 0.10 m of the nominated plan location of longitudinal joints in the base, unless otherwise shown on the Drawings.

Note that sub-base longitudinal joints need not be constructed adjacent to every joint in the base but, if required by the Contractor's placing methods, they shall be located only at specified locations, as shown on the Drawings.

Longitudinal construction joints need not be scabbled unless otherwise shown on the Drawings. They shall not be corrugated.

Where joint location is not specified, the Contractor shall advise his nominated location and the joints shall thereafter comply with the following geometric tolerances –

- a) The line of longitudinal construction joints shall not deviate from the plan or nominated position at any point by more than 25 mm;
- b) The line of longitudinal construction joints shall not deviate from a 3 m straight-edge placed along the joint by more than 20 mm, after due allowances for any planned curvature, nor more than 10 mm from a 3 m straight-edge;
- c) Longitudinal construction joints shall be square to the finished top surface of the sub-base with a tolerance of  $\pm 5^\circ$ ; and
- d) The top surface of longitudinal construction joints shall not deviate from a 3 m straight-edge placed along the joint by more than 3 mm.

Where a joint is nonconforming or the edge is damaged or spalled in excess of 25 mm, it shall be reinstated or repaired in accordance with Clause 11.2. Reinstatement shall be completed prior to the placement of the adjacent slab and repair material shall not be placed integrally with the adjacent concrete.

### **10.3 Inspection**

The Contractor shall inspect each construction joint within 24 hours of its forming in the sub-base. If non-conformance is detected in relation to geometric tolerances, the Contractor shall immediately implement Corrective Action in accordance with the Quality System requirements.

Where a joint is non-conforming or the edge is damaged, it shall be reinstated or repaired prior to the placement of the adjacent concrete.

## **11 BITUMINOUS SEAL PROTECTION LAYER**

### **11.1 General**

Where the concrete base is a jointed unreinforced concrete base, including those slabs where steel mesh is included in odd-shaped slabs, mismatched slabs and other slabs where reinforcement is included for a particular reason in what is basically a jointed unreinforced design, a bituminous seal protection layer shall be applied to the wax-cured surface of the sub-base.

For other pavement types such as continuously reinforced, jointed reinforced and steel fibre reinforced, a bituminous seal protection layer shall be applied to the cured surface of the sub-base only if specified. Otherwise a wax de-bonding shall be applied in accordance with MRTS40 *Concrete Base in Pavements*.

## 11.2 Bitumen Seal Protection Layer

The Contractor may place the sprayed bituminous seal (where applicable) upon achievement of an in-situ strength of 4.0 MPa.

Before applying the bituminous seal the following shall be carried out –

- a) The surface shall be cleaned of all loose, foreign and deleterious material;
- b) Spalled areas (with the exception of full-depth cracks) greater than 10 mm deep and 15 mm wide shall be filled in with a low-shrink rapid-hardening cement mortar or a mixture of aggregate and bitumen to provide a surface flush with the sub-base surface. The mix used shall be stable and shall adhere to the sub-base concrete;
- c) Full-depth cracks that have spalled more than 10 mm deep and 15 mm wide shall be filled in with a suitable flexible sealant or a mixture of sand and bitumen to provide a surface flush with the sub-base surface; and
- d) Where necessary and including treatment (b) and (c) above and any area where the wax curing layer has been damaged or visibly disturbed or worn by traffic, the wax curing cover shall be reinstated to provide a continuous film of wax over the whole surface of the lean mix sub-base.

Where a bituminous seal is not specified, the above spall treatment shall be applied at least 24 hours prior to placement of the base.

## 11.3 Materials

Bitumen shall be Class 170 complying with MRTS17 *Bitumen*. The bitumen shall be cut back with cutter oil, up to a maximum of 3%, to suit the pavement temperature-related requirements.

Aggregate shall have a nominal size of 7 mm and be Class A in accordance with MRTS22 *Supply of Cover Aggregate*, except that no account shall be taken of its susceptibility to polishing. Aggregate shall be free of dust and be pre-coated as per MRTS22.

## 11.4 Application

The sprayed bituminous seal shall be applied in accordance with MRTS11 *Sprayed Bituminous Surfacing (Excluding Emulsions)*.

The rate of bitumen application shall be determined from the Austroads Design of Sprayed Seals except that the rate shall be between 0.6 l/m<sup>2</sup> and 0.8 l/m<sup>2</sup>.

Immediately after spraying, the binder shall be covered with 7 mm cover aggregate, as specified in MRTS22 *Supply of Cover Aggregate*, spread at a rate determined from the Austroads Design of Sprayed Seals to provide a dense mosaic of single-stone thickness, without loose stones resting on the mosaic. The surface shall then be lightly rolled with a dual-axle, smooth pneumatic tyred, multi-wheeled roller of less than 20 tonne gross weight.

For the purpose of determining the rate of application, the traffic loading shall be taken as the construction traffic distributed over half of the one-way carriageway lanes.

## 11.5 Thickness of Bituminous Seal

The thickness of the bituminous seal shall be determined for the purpose of establishing the thickness of the sub-base to meet the specified height requirements.

For the purpose of determining survey levels, the initial curing compound is deemed to have nil thickness.

The thickness of the seal shall be taken as the Average Least Dimension (ALD) of the cover aggregate, determined in accordance with Test Method Q202.

# 12 CONFORMANCE TESTING OF PLACED CONCRETE

## 12.1 General

The process requirements shall be checked for conformance with the specified requirements during and after the construction operation, as relevant. Conformance checking shall be carried out in accordance with any maximum lot sizes, minimum testing frequencies and minimum test numbers as given in Clause 16.

## 12.2 Concrete Strength

### 12.2.1 Test Specimens

Test specimens for determining the strength of concrete in the Works shall be cores, 75 to 100 mm in diameter, cut from the Works. Cores shall be extracted from the full depth of the concrete sub-base in accordance with AS 1012.14. Coring of the sub-base shall be strictly controlled and limited to minimise its potential detrimental effects.

Specimens shall be secured, accepted, conditioned, capped and tested in accordance with AS 1012.14, subject to the following amendments to AS 1012.14 –

- a) Concrete shall have hardened enough to permit removal without disturbing the bond between the mortar and the coarse aggregate;
- b) Clause 6.3.2(b) shall be amended to read as follows: 'The diameter at any cross-section deviates from the mean diameter by more than 5 mm.;
- c) Clause 6.4(d) shall be amended to exclude dry-conditioning. Cores shall be wet conditioned by submersion in water at a temperature of  $23 \pm 5^{\circ}\text{C}$  for not less than 24 hours nor more than 72 hours immediately prior to testing;
- d) The individual core strengths shall be adjusted for length/diameter ratio in accordance with Clause 7.2 of AS 1012.14. The correction factor shall be applied to the pre-rounded core strength, in accordance with the ruling of Standards Australia Committee BD/24 dated 17 September 1992; and
- e) Clauses 9(k), 9(i), 10(h) and 10(i) shall each be amended by the addition of the following words: '... except where the strength is less than 10 MPa, in which case it shall be calculated to the nearest 0.1 MPa.'

### 12.2.2 Frequency and Location of Coring

The location for coring shall be selected by a stratified random process. The Contractor's Quality Plan shall detail the proposed method of selecting stratified random locations for sampling of cores within a lot. Further samples shall be taken at specific (non-random) locations which are visually non-homogeneous and/or non-representative. In addition:

- a) For non-transition lots, the Contractor shall take from each lot one core specimen per  $100 \text{ m}^3$  of concrete sub-base, with a minimum of two and a maximum of 20 cores; and
- b) For transition lots, the Contractor shall take from each lot one core specimen per  $50 \text{ m}^3$  of concrete sub-base, with a minimum of two cores and a maximum of 20 cores.

### 12.2.3 Determination of Compression Strength

Cores shall be tested in accordance with AS 1012.14, amended in accordance with Clause 12.2.1. Bituminous seal shall be trimmed from the cores prior to testing.

### 12.2.4 Restoration of Core Holes

All core holes in the sub-base shall be restored with concrete having the same compressive strength of that in the sub-base but with maximum nominal aggregate size of 10 mm.

The cost of restoring all holes in the sub-base shall be borne by the party which secured the cores.

## 12.3 Geometric Standards

### 12.3.1 Horizontal Alignment Tolerances

The Contractor shall survey the alignment for conformance with this Technical Standard within 24 hours of paving or as otherwise approved by the Administrator. If a non-conformance is detected, the Contractor shall immediately implement Corrective Action in accordance with the Quality System requirements.

The geometric tolerances shall be checked by a method of random stratified sampling.

Each outer edge shall be tested for alignment conformance at random locations and at a frequency not less than the following, commencing with trial paving and thereafter independent of the boundaries to lots –

- a) One test per 10 linear metres of edge, until five conforming results are recorded; and thereafter
- b) One test per 50 linear metres of edge.

### **12.3.2 Straight-Edge Tolerances**

The top surface of each lot of sub-base shall be assessed for conformance with the 3 m and 150 mm straight-edge tolerances in Clause 9.4.2.

Straight-edge conformance shall be tested at random locations, commencing with trial paving and thereafter independent of the boundaries to lots, and at a frequency not less than the following with a 3 m straight-edge for each of the longitudinal and transverse alignments –

- a) One test per 10 linear metres of paving run, until five conforming results are recorded; and thereafter
- b) One test per 100 linear metres of paving run.

Straight-edge conformance shall be tested at random locations, commencing with trial paving and thereafter independent of the boundaries to lots, and at a frequency not less than the following with a 150 mm straight-edge for each of the longitudinal and transverse alignments –

- a) One test per 20 linear metres of paving run, until five conforming results are recorded; and thereafter
- b) One test per 200 linear metres of paving run.

Locations identified as nonconforming shall be rectified in accordance with Clause 14.

### **12.3.3 Surface Height**

The top surface of each lot of sub-base shall be assessed for surface height conformance in accordance with Clause 9.4.3. The Contractor shall carry out a survey in accordance with Clause 9.4.5.

Levels shall be taken with a flat-based staff of base area not less than 300 mm<sup>2</sup> nor greater than 400 mm<sup>2</sup>, and at locations as follows –

- a) at the location on the sub-base immediately below the cross-section offset locations given for the base in Figure 12.3.3, with a tolerance of  $\pm 0.05$  m; and
- b) at longitudinal spacings of 7.5 m.

Levels shall be reported to the nearest millimetre.

The thickness of the concrete sub-base shall be determined by two methods –

- a) Subtracting the height of the top surface of the lean mix concrete sub-base from the height of the layer immediately below the lean-mix concrete sub-base at the same longitudinal and offset locations as the sub-base; and
- b) Determining the concrete thickness of cores taken from the sub-base (See Clause 12.2)

The Administrator may authorise coring in areas where the thickness as calculated from survey results is nonconforming, in which case 40 mm diameter cores shall be taken.

Wherever a core result differs by 5 mm or more from a survey result(s) which is located within 1.5 m of the core, or by 10 mm or more from a survey result(s) which is located between 1.5 m and 2.5 m from the core, the core result shall be accepted and the survey result(s) shall be omitted from the assessment.

The average thickness for each lot shall be calculated using all survey and core results from that lot, with the exception of any survey results omitted as provided above. The result shall be rounded to the nearest 1 mm.

Figure 12.3.3 – Survey Height Cross-Sections

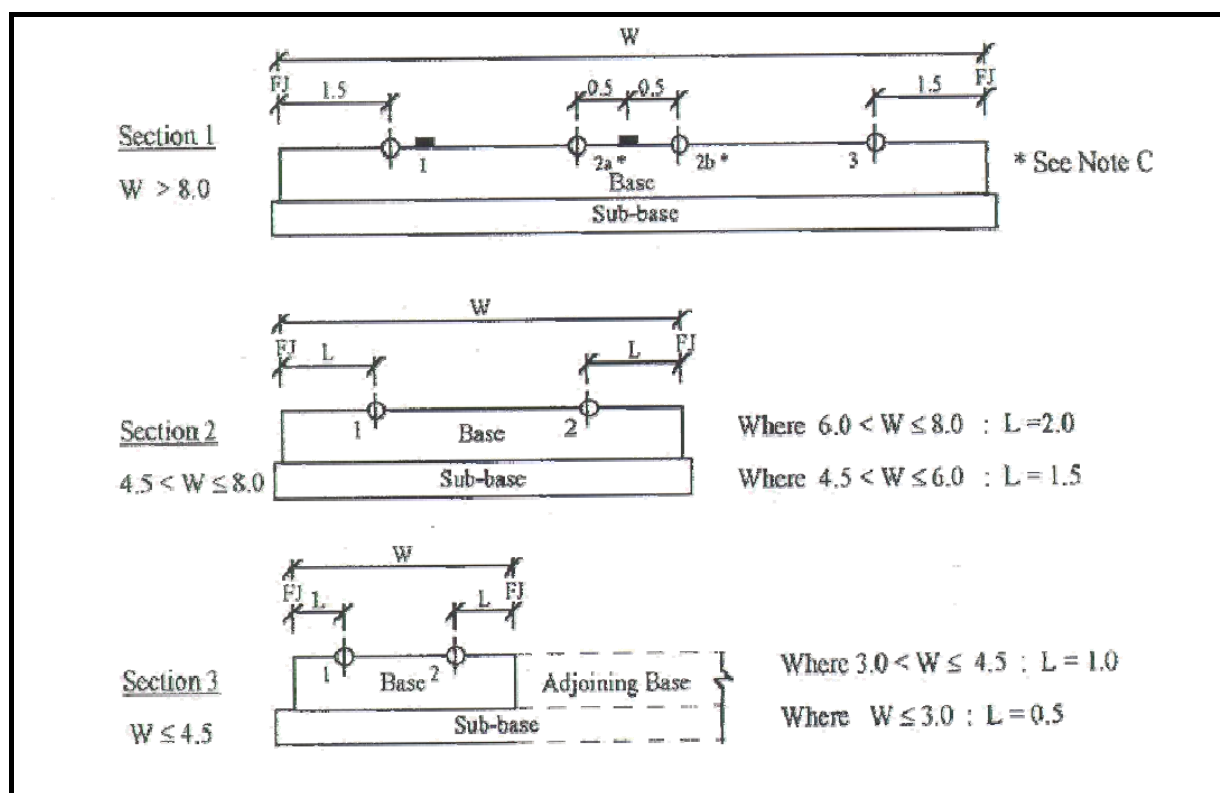

Notes to Figure 12.3.3 –

All dimensions are in metres (m).

Induced longitudinal joints shall be ignored for the purpose of locating survey points and are not shown in Figure 12.3.3.

In Section 1, the Contractor shall nominate to take a survey either at point 2a or 2b.

Symbols

Symbol	FJ	W	,	-
Meaning	Formed joint or edge	Paving width between formed joints or edges	Lane lines	Survey points

### 12.4 Curing Compound Rate of Application

The application rate of curing compound shall be checked for conformance to the requirements of this Technical Standard as follows –

- by calculating the average application rate from the total measured quantity of compound applied over each paving run; and
- by testing the local amount of curing compound as measured on test mats placed on the pavement. The application rate shall be calculated as the mean of the local rates falling on three felt mats, each approximately 0.25 m<sup>2</sup> in area and placed randomly within an area of 100 m<sup>2</sup> on the surface to be treated. Testing shall be carried out at a frequency of once per 2000 m<sup>2</sup> of sub-base.

Application shall be deemed to be conforming if the average result is not less than the specified rate and if no single result is more than 5% below the specified rate.

Any portion of a lot on which the application does not conform shall be resprayed within 6 hours at an application rate not less than twice the deficiency in the original application.

## 13 MONITORING TESTING

In addition to the tests specified in this Technical Standard, charts shall be maintained at least for the tests results specified in Clause 16.3.

## 14 RECTIFICATION

### 14.1 Removal and Replacement of Sub-base

#### 14.1.1 Marking of Sections

Where nonconforming sub-base is to be removed and replaced, the Contractor shall submit the proposed method to the Administrator before commencing such work.

The sections of nonconforming sub-base shall be marked out such that all edges are at right angles.

Submission of this proposal shall constitute. **Hold Point 9.**

#### 14.1.2 Sawing and Removing Nonconforming Sections

At each end of the section to be removed a transverse sawcut shall be made as follows –

- a) in a straight line and continuous between adjacent longitudinal joints and at an angle of not less than 85° to the longitudinal joint; and
- b) to a depth of 40 ± 10 mm.

The nonconforming concrete shall be removed within these sawcuts so that the face of the construction joint is left scabbled below, but not within, the depth of the sawcut.

Oversawing into the adjoining sub-base shall not be permitted.

The concrete shall be removed at each longitudinal edge of the nonconforming sub-base –

- a) in such a way that the exposed face complies with the criteria for longitudinal construction joints as defined in this Technical Standard; and
- b) either to an existing longitudinal joint or edge, or to a newly sawn longitudinal joint.

Longitudinal sawcuts shall not extend more than 100 mm beyond the transverse sawcuts which define the limits of removal.

No oversawing shall be permitted on any additional internal sawcuts which the Contractor may make to aid the removal of the sub-base.

The Contractor shall dispose of the removed sub-base at a location given in the documents or, if not indicated, at a location and manner proposed by the Contractor and approved by the Administrator.

### 14.2 Rectification of Finished Sub-base Surface

Individual locations identified as nonconforming in accordance with Clause 12.2 shall be rectified as follows –

- a) High areas shall be ground, and then finished by methods detailed in Clause 11 to provide a surface consistent with the adjacent concrete and which conforms to Clause 12.3;
- b) Alternatively, for areas which are high by 15 mm or less, the Contractor may propose a redesign of finished levels; and
- c) Areas more than 20 mm below the level shown on the Drawings shall be removed in accordance with Clause 14.1.

## 15 UTILISATION OF A NONCONFORMING LOT FOR A REDUCED LEVEL OF SERVICE

### 15.1 Concrete Strength

A nonconforming lot with respect to concrete strength may be acceptable for utilisation for a reduced level of service if the concrete has an insitu strength of between 4.0 MPa and 5.0 MPa within 42 days of placement.

Sub-base which fails to achieve an insitu strength of 4.0 MPa within 42 days of placement shall be removed and replaced.

### **15.2 Reduced Pavement Thickness**

As well as any requirements specified by the Administrator, a nonconforming lot with respect to sub-base thickness (Clause 9.4.4) may be acceptable for utilisation for a reduced level of service if the arithmetic average thickness of sub-base is not less than the specified sub-base thickness minus 10 mm, providing that it represents isolated sections and such sections comprise no more than 10% of the area of sub-base lot and also providing that the specified minimum thickness and surface height of the concrete base are maintained.

### **15.3 Plastic Shrinkage Cracking**

As well as any requirements specified by the Administrator, where plastic shrinkage cracks of length less than 500 mm and an initial depth less than 50% of the slab thickness which do not intersect a formed edge occur, the slab may be accepted, provided a corrective action statement is given to the Administrator and corrective action is implemented.

## **16 LOT SIZES AND TESTING**

### **16.1 General**

This clause details requirements for the manufacture and placement of concrete and all constituent materials.

### **16.2 Lots**

#### **16.2.1 General**

This Technical Standard is based on the use of lots, which are homogeneous (in the context of the requirements of the Standard) identifiable quantities defined in forms such as –

- a) length, e.g. linear metres;
- b) area, e.g. square metres;
- c) volume, e.g. cubic metres;
- d) mass, e.g. tonnes; and
- e) units of manufacture, e.g. batches, etc.

of items and material types identified by name and Standard requirements such as –

- a) aggregate;
- b) cement;
- c) fly ash;
- d) slag;
- e) additives;
- f) steel; and
- g) class and size of concrete.

from which samples are taken and about which decisions are made on the basis of such processes as –

- a) tests;
- b) inspections;
- c) test procedures;
- d) observations; and/or
- e) auditing.

The minimum and/or maximum lot sizes and/or testing frequencies given in Clause 16 are not sufficient to check the lot for homogeneity. The Contractor should check for homogeneity on a regular basis but not less than the frequency given in Clause 16. The lot can be audited for homogeneity at any time.

Homogeneity can be assessed by utilisation of the Technical Standard requirements for the particular item or material and by –

- a) conducting a statistically significant number of tests, at least 30; and/or
- b) subdividing the initially chosen lot in any number and size of smaller lots and testing each smaller lot as required and in accordance with the minimum testing frequencies given in Clause 16.

### **16.2.2 Concrete Lots**

A concrete lot shall consist of batches of concrete of the same class, produced and placed in an essentially uniform and continuous manner. A lot shall not extend beyond the boundaries of a section of pavement cast or paved in one continuous operation and/or operating time up to a maximum operating time of one calendar day and/or beyond any construction joint.

Concrete sub-base lots which are not placed with a mechanical paver (see Clause 9.2), and including the sections specified below, shall be deemed 'transition lots'. At transverse construction joints in mechanically paved sub-base, the work within 3 m each side of the joint is deemed to constitute two discrete transition lots, regardless of the methods employed at the joint. Transition lots shall be treated as other lots except for relative compaction testing.

At transitions (from machine paving to hand paving) which are remote from a transverse construction joint, the work within 3 m each side of the transition point is deemed to constitute two discrete transition lots, regardless of the methods employed at the transition. (See Table 3.2 for definition of terms).

### **16.2.3 Aggregate Lots**

An aggregate lot shall consist of a discrete stockpile solely for use in the Works. These materials shall not be used for any other Works. The stockpile shall be formed by either of the following methods –

- a) a stockpile for each lot; or
- b) a continuous, rectangular-in-plan-view shaped stockpile where material is added at one end and withdrawn at the other end, with lots being identified by pegged locations within the stockpile.

## **16.3 Lot Sizes, Tests and Testing Frequencies**

### **16.3.1 General**

The Contractor shall be responsible for selecting the lot sizes, tests, inspections and testing and inspection frequencies to ensure that the Works conform to all the standards and requirements of the Technical Standard.

The lot sizes, tests and inspection and test frequencies given below represent absolute minimum requirements.

There are two levels of maximum lot sizes and minimum testing frequencies given below. The Contractor shall comply with the requirements of the Normal Level unless approval is given by the Administrator to revert to the Reduced Level.

Where a Contractor is operating at the Reduced Level and a nonconformance occurs for any standard or requirement in a lot, the Contractor shall immediately go back to the Normal Level of testing, until approval is given by the Administrator to revert to the Reduced Level.

Approval to revert to the Reduced Level shall normally be given only after no nonconformances have occurred in several lots and the Contractor can demonstrate that processes are under control and consistent.

The requirements in Clause 7 represent an absolute minimum testing program. The Contractor remains responsible for performing sufficient tests and inspections to ensure that the lot conforms to all the standards and requirements of the Technical Standard.

### **16.3.2 Constituent Materials**

Details of lot sizes and testing frequencies for constituent materials are included in Table 16.3.2.

**Table 16.3.2 – Constituent Materials Testing**

Characteristic Tested	Maximum Lot Size		Minimum Testing Frequency	
	Normal Level	Reduced Level	Normal Level	Reduced Level
<b>CEMENTITIOUS MATERIALS</b> Cement : AS 3972 Fly Ash: AS 3582.1 Slag: AS 3582.2	1 500 tonnes	1 500 tonnes	once	once
Loss on Ignition and Fineness for Fly Ash	per tanker delivery	per tanker delivery	once	subject to the air content conforming to specified requirements, one in ten
<b>WATER</b> Impurities in Mixing Water	30 000 m <sup>3</sup>	30 000 m <sup>3</sup>	once	once
<b>CHEMICAL ADMIXTURES</b> AS 1478.1	batch	Batch	once	once

### 16.3.3 Coarse Aggregates

Details of the characteristics, lot sizes and testing frequencies of coarse aggregates are included in Table 16.3.3.

**Table 16.3.3 – Coarse Aggregates Testing**

Characteristic Tested	Maximum Lot Size		Minimum Testing Frequency	
	Normal Level	Reduced Level	Normal Level	Reduced Level
Water Absorption	2 000 tonnes	5 000 tonnes	1	1
Bulk Density	2 000 tonnes	5 000 tonnes	3	3
Material < 75 micrometre	2 000 tonnes	5 000 tonnes	3	3
Material < 2 micrometre	2 000 tonnes	5 000 tonnes	3	3
Particle Shape: (3:1 ratio) and (2:1 ratio)	2 000 tonnes	5 000 tonnes	3	3
Flakiness Index	2 000 tonnes	5 000 tonnes	3	3
Light Particles	2 000 tonnes	5 000 tonnes	1	1
Weak Particles	2 000 tonnes	5 000 tonnes	1	1
Iron Unsoundness	2 000 tonnes	5 000 tonnes	1	1
Falling or Dusting Unsoundness	2 000 tonnes	5 000 tonnes	1	1
10% Fines Value (Wet)	2 000 tonnes	5 000 tonnes	1	1
Wet/Dry Strength Variation	2 000 tonnes	5 000 tonnes	1	1
Degradation Factor	2 000 tonnes	5 000 tonnes	1	1
Coarse Aggregate Grading	2 000 tonnes	5 000 tonnes	3	3

### 16.3.4 Fine Aggregate Testing of Source Rock for Manufactured Sands

Details of the characteristics, lot sizes and testing frequencies of source rock for manufactured sands are included in Table 16.3.4.

**Table 16.3.4 – Source Rock Testing**

Characteristic Tested	Maximum Lot Size		Minimum Testing Frequency	
	Normal Level	Reduced Level	Normal Level	Reduced Level
Light Particles	2 000 tonnes	5 000 tonnes	1	1
Weak Particles	2 000 tonnes	5 000 tonnes	1	1
10% Fines Value (Wet)	2 000 tonnes	5 000 tonnes	1	1
Wet/Dry Strength Variation	2 000 tonnes	5 000 tonnes	1	1
Degradation Factor	2 000 tonnes	5 000 tonnes	1	1

### 16.3.5 Fine Aggregates

Details of the characteristics, lot sizes and testing frequencies of fine aggregates are included in Table 16.3.5.

**Table 16.3.5 – Fine Aggregates Testing**

Characteristic Tested	Maximum Lot Size		Minimum Testing Frequency	
	Normal Level	Reduced Level	Normal Level	Reduced Level
Water Absorption	2 000 tonnes	5 000 tonnes	1	1
Bulk Density	2 000 tonnes	5 000 tonnes	3	3
Material < 75 micrometre	2 000 tonnes	5 000 tonnes	3	3
Material < 2 micrometre	2 000 tonnes	5 000 tonnes	3	3
Organic Impurities	2 000 tonnes	5 000 tonnes	3	3
Sugar Content	2 000 tonnes	5 000 tonnes	3	3
Iron Unsoundness	2 000 tonnes	5 000 tonnes	1	1
Falling or Dusting Unsoundness	2 000 tonnes	5 000 tonnes	1	1
Moisture Content	Stockpile	Stockpile	3 per day and after rain	3 per day and after rain

### 16.3.6 Combined Aggregate

Details of the grading, lot sizes and testing frequencies of combined aggregate are included in Table 16.3.6.

**Table 16.3.6 – Combined Aggregate Testing**

Characteristic Tested	Maximum Lot Size		Minimum Testing Frequency	
	Normal Level	Reduced Level	Normal Level	Reduced Level
Combined Aggregate Grading	2 000 tonnes	5 000 tonnes	3	3

### 16.3.7 Alkali Reactive Testing

Details of the lot sizes and testing frequencies for alkali reactive testing are included in Table 16.3.7.

**Table 16.3.7 – Alkali Reactive Testing**

Characteristic Tested	Maximum Lot Size		Minimum Testing Frequency	
	Normal Level	Reduced Level	Normal Level	Reduced Level
Accelerated Alkali Silica Reaction for concrete with cementitious material with less than 20% fly ash	15 000 tonnes	15 000 tonnes	1	1

### 16.3.8 Concrete Production and Supply

Details of the characteristics, lot sizes and testing frequencies for concrete are included in Table 16.3.8.

**Table 16.3.8 – Testing of Concrete Production and Supply**

Characteristic Tested	Maximum Lot Size		Minimum Testing Frequency	
	Normal Level	Reduced Level	Normal Level	Reduced Level
Consistence	See Below	See Below	See Below(1)	See Below(1)
Drying Shrinkage	first two lots used for 28-day compressive strength testing	every tenth lot used for 28-day compressive strength testing	once for first two lots	once every tenth lot
Air Content	Truck load	200 m <sup>3</sup>	once per load(2)	once per load(2)
Mixer Uniformity	30 000 m <sup>3</sup>	30 000 m <sup>3</sup>	Clause 6.5.4	Clause 6.5.4
Chemical Content	5 000 m <sup>3</sup>	10 000 m <sup>3</sup>	once	once

1. The frequency of routine consistency testing shall be as follows –

Initial daily slumping: Test every load prior to discharge until 8 consecutive conforming loads are tested. Calculate the standard deviation (SD) of the results of these 8 loads.

If  $SD \leq 8.0$  mm: go to Process Slumping.

If  $SD > 8.0$  mm: continue slumping every load until any 8 consecutive loads have a  $SD \leq 8.0$  mm

Process Slumping: Slump at least every fourth load.

If a nonconforming slump is measured, all loads thereafter shall be slump tested (prior to discharge) until the SD of the test results of 6 consecutive loads is  $\leq 8$  mm, at which time testing may revert to each fourth load.

2. Air voids testing shall be carried out daily at the following frequency:

- a) one per load until three conforming results are obtained; and thereafter,
- b) one per 100 m<sup>3</sup> until four consecutive conforming results are obtained, and thereafter,
- c) one per 200 m<sup>3</sup> for the remainder of the day.

### 16.3.9 Protection Layer Treatment

Details of the characteristics, lot sizes and testing frequencies for Protection Layer treatments are included in Table 16.3.9.

**Table 16.3.9 – Protection Layer Treatment**

Characteristic Tested	Maximum Lot Size		Minimum Testing Frequency	
	Normal Level	Reduced Level	Normal Level	Reduced Level
As per bitumen Standards	Each lot	each lot	each lot	each lot

### 16.3.10 Placement of Concrete Sub-Base

Details of the characteristics, lot sizes and testing frequencies for placement of concrete sub-base are included in Table 16.3.10.

**Table 16.3.10 – Testing of Concrete Sub-base Placement**

Characteristic Tested	Maximum Lot Size		Minimum Testing Frequency	
	Normal Level	Reduced Level	Normal Level	Reduced Level
<b>CURING COMPOUND</b>				
Wax as per MRTS42				
Compliance of Curing Compound	batch	batch	once per batch	once per batch
Application Rate	each lot	each lot	once per 2 000 m <sup>2</sup>	once per 2 000 m <sup>2</sup>
<b>TEMPERATURE</b>				
Air and Concrete	800 m <sup>3</sup>	a day's continuous production or between construction joints	once per batch	once per batch
<b>CONCRETE STRENGTH</b>				
Non-Transition Lots	same as for consistency testing	same as for consistency testing	same as for consistency testing	same as for consistency testing
Transition Lots	each lot	each lot	1 per 50 m <sup>3</sup> up to a minimum of 2 cores per lot	1 per 100 m <sup>3</sup> up to a minimum of 2 cores per lot
<b>GEOMETRICS</b>				
Horizontal Alignment	800 m <sup>3</sup>	a day's continuous production or between construction joints	1 test per 10 linear metres	1 test per 50 linear metres
3 m Straight-Edge	800 m <sup>3</sup>	a day's continuous production or between construction joints	1 test per 10 linear metres	1 test per 100 linear metres
150 mm Straight-Edge	800 m <sup>3</sup>	a day's continuous production or between construction joints	1 test per 20 linear metres	1 test per 200 linear metres
Surface Heights	800 m <sup>3</sup>	a day's continuous production or between construction joints	Clause 12.3.3	Clause 12.3.3
Thickness	800 m <sup>3</sup>	a day's continuous production or between construction joints	Clause 12.3.3	Clause 12.3.3

### 16.3.11 Pavement Joints

Details of the characteristics, lot sizes and testing frequencies for pavement joints are included in Table 16.3.11.

*Table 16.3.11 – Pavement Joints Testing*

Characteristic Tested	Maximum Lot Size		Minimum Testing Frequency	
	Normal Level	Reduced Level	Normal Level	Reduced Level
Transverse and Longitudinal Construction Joints	each joint	every 3rd joint	inspect each joint	inspect each joint