



## Guideline

# Options for Designers of Pedestrian and Cyclist Bridges to achieve value-for-money

November 2023



## Copyright

© The State of Queensland (Department of Transport and Main Roads) 2023.

## Licence



This work is licensed by the State of Queensland (Department of Transport and Main Roads) under a Creative Commons Attribution (CC BY) 4.0 International licence.

## CC BY licence summary statement

In essence, you are free to copy, communicate and adapt this work, as long as you attribute the work to the State of Queensland (Department of Transport and Main Roads). To view a copy of this licence, visit: <https://creativecommons.org/licenses/by/4.0/>

## Translating and interpreting assistance



The Queensland Government is committed to providing accessible services to Queenslanders from all cultural and linguistic backgrounds. If you have difficulty understanding this publication and need a translator, please call the Translating and Interpreting Service (TIS National) on 13 14 50 and ask them to telephone the Queensland Department of Transport and Main Roads on 13 74 68.

## Disclaimer

While every care has been taken in preparing this publication, the State of Queensland accepts no responsibility for decisions or actions taken as a result of any data, information, statement or advice, expressed or implied, contained within. To the best of our knowledge, the content was correct at the time of publishing.

## Feedback

Please send your feedback regarding this document to: [tmr.techdocs@tmr.qld.gov.au](mailto:tmr.techdocs@tmr.qld.gov.au)

# Contents

- 1 Introduction ..... 1**
- 1.1 Preamble..... 1
- 1.2 Abbreviations ..... 2
- 2 Design considerations ..... 2**
- 2.1 Design issues..... 2
- 2.2 Crossing types ..... 4
- 3 Cost considerations ..... 5**
- 3.1 Whole-of-life costs ..... 5
- 3.2 Cost factors..... 7
- 4 Design references..... 10**
- 4.1 General ..... 10
- 4.2 Bridge Design Code..... 11
- 4.3 Road association guides..... 12
- 4.4 Queensland Department of Transport and Main Roads..... 12
  - 4.4.1 *Design Criteria for Bridges and Other Structures*..... 12
  - 4.4.2 *Road Planning and Design Manual (RPDM)*..... 12
  - 4.4.3 *Technical notes* ..... 12
  - 4.4.4 *Transport and Main Roads Specifications* ..... 12
  - 4.4.5 *Standard drawings*..... 13
  - 4.4.6 *Miscellaneous guidelines* ..... 13
- 4.5 Queensland Rail (QR) ..... 13
- 4.6 Brisbane City Council (BCC) ..... 13
- 4.7 Regional local authorities..... 13
- 4.8 Queensland Department of Education, Training and Employment ..... 13
- 4.9 Australian Standards ..... 14
  - 4.9.1 *Introduction*..... 14
  - 4.9.2 *Loads*..... 14
  - 4.9.3 *Access for users with a disability*..... 14
  - 4.9.4 *Slip resistance* ..... 14
- 4.10 Australian Building Codes Board (ABCB)..... 14
- 4.11 Industry publications ..... 14
- 5 Aesthetics..... 14**
- 6 Planning..... 17**
- 6.1 Strategic planning ..... 17
- 6.2 Implementation ..... 18
- 7 Options analysis ..... 19**
- 7.1 General ..... 19
- 7.2 Design options ..... 19
- 7.3 Delivery options ..... 20
- 8 Site constraints ..... 21**
- 9 Design life..... 23**

<b>10</b>	<b>User envelope .....</b>	<b>24</b>
10.1	General .....	24
10.2	Width .....	25
10.3	Height .....	26
<b>11</b>	<b>Clearances .....</b>	<b>26</b>
11.1	General .....	26
11.2	Vertical .....	26
11.3	Horizontal .....	28
<b>12</b>	<b>Access and mobility .....</b>	<b>28</b>
12.1	General .....	28
12.2	Walkways, ramps and landings .....	30
12.3	Stairs .....	31
<b>13</b>	<b>Materials .....</b>	<b>33</b>
13.1	General .....	33
13.2	Concrete .....	34
13.3	Steel .....	35
13.4	Aluminium .....	38
13.5	Timber .....	39
13.6	Fibre Reinforced Polymers (FRP) .....	40
13.7	Recycled plastics .....	40
13.8	Misuse and vandalism .....	40
<b>14</b>	<b>Bridge types .....</b>	<b>41</b>
14.1	General .....	41
14.2	Span lengths .....	41
14.3	Single girder bridges .....	42
14.3.1	<i>Introduction</i> .....	42
14.3.2	<i>Single reinforced and / or prestressed concrete girder</i> .....	43
14.3.3	<i>Single steel girder</i> .....	43
14.4	Multi-girder bridges .....	46
14.4.1	<i>Introduction</i> .....	46
14.4.2	<i>Concrete girders</i> .....	47
14.4.3	<i>Steel girders</i> .....	49
14.4.4	<i>FRP girders</i> .....	50
14.5	Concrete slabs .....	50
14.5.1	<i>Insitu concrete slabs</i> .....	50
14.5.2	<i>Precast concrete slabs</i> .....	51
14.5.3	<i>Orthotropic concrete slabs</i> .....	52
14.6	Truss bridges .....	53
14.6.1	<i>General</i> .....	53
14.6.2	<i>Steel trusses</i> .....	54
14.6.3	<i>Aluminium trusses</i> .....	55
14.6.4	<i>FRP trusses</i> .....	57
14.7	Arch bridges .....	57
14.8	Cable supported bridges .....	58

<b>15 Deck types</b>	<b>59</b>
15.1 General	59
15.2 Concrete decks	60
15.2.1 Precast concrete decks	60
15.2.2 Precast concrete panels with in-situ concrete infill decks	60
15.2.3 Insitu concrete decks	61
15.3 Aluminium decks	62
15.4 FRP decks	64
15.5 Asphalt deck surfacing	64
15.6 Timber decks	64
15.7 Recycled plastic	66
15.8 Miscellaneous composites	66
15.9 Slip resistant surfaces	67
15.10 Jointing	67
<b>16 Vehicle access</b>	<b>67</b>
<b>17 Loads</b>	<b>68</b>
17.1 General	68
17.2 Pedestrian and cycle path loads	69
17.3 Vehicle loads	69
17.3.1 General	69
17.3.2 Bridge Design Code, AS(/NZS) 5100:2017	70
17.3.3 The Department of Transport and Main Roads	70
17.3.4 Australian Standards	70
17.3.5 Brisbane City Council (BCC)	70
17.4 Lateral loads	70
17.5 Barrier loads	71
<b>18 Collision impact</b>	<b>71</b>
18.1 Road vehicle	71
18.2 Rail vehicle	71
18.3 Waterway traffic / ship collision	71
<b>19 Serviceability</b>	<b>72</b>
19.1 General	72
19.2 Static deflections	72
19.3 Dynamic behaviour	72
<b>20 Barriers</b>	<b>73</b>
20.1 General	73
20.2 Railings	76
20.3 Balustrades	76
20.4 Kerbs	77
<b>21 Drainage and flood immunity</b>	<b>77</b>
21.1 Cross-fall	77

21.2 Kerb .....	78
21.3 Scuppers.....	78
21.4 Flood immunity.....	78
<b>22 Anti-throw screens.....</b>	<b>78</b>
<b>23 Foundations .....</b>	<b>80</b>
23.1 General .....	80
23.2 Spread footings.....	81
23.3 Driven piles .....	81
23.4 Cast in place piles.....	81
<b>24 Ease of maintenance .....</b>	<b>82</b>
<b>25 Innovations.....</b>	<b>83</b>
<b>26 Recommendations.....</b>	<b>84</b>

## Tables

Table 1.2 – Table of acronyms and abbreviations .....	2
Table 3.2 – Potential factors influencing the cost of cycle and pedestrian bridges.....	7
Table 4.1 - Referenced documents .....	11
Table 12.2(a) – General walkway configurations .....	30
Table 12.2(b) – General ramp configurations.....	30
Table 12.2(c) – Enhanced ramp configurations .....	30
Table 12.3 – Stairway configurations .....	31

## Figures

Figure 1.1 – A cyclist crossing a commuter cycle bridge on the Veloway 1 (V1), Brisbane .....	1
Figure 2.1 – Elements of the pedestrian / cycle bridge .....	3
Figure 2.2(a) – Kurilpa shared use bridge over the Brisbane River, viewed from the Bicentennial shared use bikeway and boardwalk .....	4
Figure 2.2(b) – Goodna State School shared use bridge over the Ipswich rail line and Ipswich Road. .	4
Figure 2.2(c) – Shared use waterway crossing .....	5
Figure 5(a) – Griffith University shared use bridge, Gold Coast .....	15
Figure 5(b) – Moggill Road cycle bridge, Indooroopilly .....	15
Figure 5(c) – Kurilpa Bridge pier, Tank Street, Brisbane .....	16
Figure 6.1 – SET planning layout for Juliette Street cycle bridge .....	17
Figure 6.2 – Widened substructure to enable future erection of superstructure .....	18
Figure 7.2(a) – Toowong crossing over Western Arterial and bikeway .....	19

Figure 7.2(b) – Concept design for Toowong Crossing during Options Analysis .....	20
Figure 7.3(a) – Jack Pesch Bridge – original design.....	20
Figure 7.3(b) – Jack Pesch Bridge – final design.....	20
Figure 8(a) – Design concept for Birdwood Road cycle bridge.....	22
Figure 8(b) – Bulimba Creek bridge, Eight Mile Plains .....	22
Figure 9 – Pedestrian bridge over Central Station, Brisbane.....	23
Figure 10.1 – Goodwill Bridge, Brisbane.....	24
Figure 11.2(a) – Vertical clearance at Kurilpa Bridge .....	27
Figure 11.2(b) – Combined stop barrier and signage at the Hovenring.....	28
Figure 12.1 – Goodna State School shared use bridge access facilities .....	29
Figure 12.2 – Approach ramp on Toowong Crossing .....	31
Figure 12.3(a) – Access stairs at Goodna State School bridge .....	32
Figure 12.3(b) – Stairway access for students at Redcliffe State High School.....	32
Figure 12.3(c) – Stairs only access to Sydney Harbour Bridge cycleway.....	33
Figure 13.1 – Toowong Crossing shared use bridge .....	34
Figure 13.3(a) – Truss joint detail.....	35
Figure 13.3(b) – Anderson Road bridge, Cairns .....	37
Figure 13.3(c) – Juliette Street bridge, Brisbane.....	37
Figure 13.3(d) – Stainless steel hold down bolts .....	38
Figure 13.5 – Cultural Centre Boardwalk, Brisbane.....	39
Figure 13.8(a) – Fire damage to recycled plastic deck .....	40
Figure 13.8(b) – Damage to lightweight aluminium balustrade.....	41
Figure 14.3.2(a) – Moggill Road cycle bridge.....	43
Figure 14.3.2(b) – Girder at Moggill Road bridge.....	43
Figure 14.3.3(a) – Falcon Street bridge .....	44
Figure 14.3.3(b) – Steel girder at Falcon Street bridge .....	44
Figure 14.3.3(c) – Stanley Street on-ramp bridge.....	45
Figure 14.3.3(d) – Stanley Street on-ramp bridge type cross section.....	45
Figure 14.4.1 – Girder arrangement at Schulz Canal shared use bridge .....	46
Figure 14.4.2(a) – Witton Creek bridge on the Centenary Highway cycleway at Indooroopilly .....	47
Figure 14.4.2(b) – Type cross section of the Witton Creek bridge.....	47
Figure 14.4.2(c) – Type cross section of the Lewisham Street bridge .....	48
Figure 14.4.2(d) – Barfoot Street footbridge type cross section.....	48

Figure 14.4.3(a) – The Fearnley Street bridge in Cairns.....	49
Figure 14.4.3(b) – Type cross section of the Fearnley Street bridge.....	49
Figure 14.4.4 – FRP girder bridge on the Coronation Drive cycleway.....	50
Figure 14.5.1 – Pedestrian bridge at Rushcutters Bay, Sydney.....	51
Figure 14.5.2 – Maleny Trail shared use bridge.....	51
Figure 14.5.3.2 – Honeyeater Drive shared use bridge cross section.....	52
Figure 14.5.3.3 – V1 Bulimba Creek cycle bridge cross section.....	53
Figure 14.6.1 – Bridge at Moody Creek, Cairns.....	53
Figure 14.6.2(a) – Ekibin Creek cycle bridge.....	54
Figure 14.6.2(b) – Juliette Street cycle bridge.....	55
Figure 14.6.3(a) – Jindalee Park bridge.....	56
Figure 14.6.3(b) – Eudlo Creek shared use bridge (during construction).....	56
Figure 14.6.4 – Ballin Park shared use FRP truss bridge, Toowoomba.....	57
Figure 14.7(a) – Springfield shared use bridge.....	58
Figure 14.7(b) – Goodwill shared use bridge.....	58
Figure 14.8 – Jack Pesch cable stayed bridge at Indooroopilly.....	59
Figure 15.2.1 – Eudlo Creek bridge (under construction) showing precast deck slabs.....	60
Figure 15.2.2 – Type cross section at Schulz Canal.....	61
Figure 15.2.3(a) – Moreton Bay Rail shared use bridge over Saltwater Creek.....	62
Figure 15.2.3(b) – ZAM coated steel sacrificial formwork at Ekibin Creek on the V1.....	62
Figure 15.3(a) – Bridge over Saltwater Creek at Aeroglen, Cairns.....	63
Figure 15.3(b) – Textured deck surface on bridge at Aeroglen.....	63
Figure 15.3(c) – Section through aluminium deck panels at Aeroglen.....	63
Figure 15.4 – Section through London Street cycle bridge deck on the V1.....	64
Figure 15.6(a) – Timber deck on bridge over Bulimba Creek (Ditmas Street, Wishart).....	64
Figure 15.6(b) – Timber deck on bridge over Bulimba Creek (Craig Street, Wishart).....	65
Figure 15.6(c) – Fixing for the timber deck on the bridge over Bulimba Creek (near Ditmas Street) ...	65
Figure 15.7(a) – Plan view of recycled plastic deck planks.....	66
Figure 15.7(b) – Elevation view of recycled plastic deck planks.....	66
Figure 15.9 – Damage to anti-slip coating on steel deck at Falcon Street.....	67
Figure 16 – Bridge deck damage due to inappropriate vehicle access.....	68
Figure 17.2 – Pedestrian and cycle bridge live loads from AS/(NZS) 5100:2017.....	69
Figure 20.1(a) – Lattice truss balustrade.....	73



Figure 20.1(b) – Bespoke balustrade at Moggill Road cycle bridge ..... 74

Figure 20.1(c) – Balustrade at Jack Pesch Bridge, Indooroopilly ..... 74

Figure 20.1(d) – Bespoke barrier design for the Cairns Connect bridge ..... 75

Figure 20.1(e) – Installed proprietary barrier for the Cairns Connect bridge ..... 75

Figure 22(a) – Protection screens (from the Bridge Design Code, AS(/NZS) 5100:2017) ..... 79

Figure 22(b) – Lewisham Street cycle bridge..... 80

Figure 23.4 – 900 diameter piles for Lewisham Street cycle bridge on V1, Brisbane ..... 81

Figure 24 – Maintenance work at Merivale Rail bridge ..... 82

Figure 25 – Auke Vleerstraat bridge at Enschede (The Netherlands), under construction ..... 83

## 1 Introduction

### 1.1 Preamble

Bridges for cyclists, pedestrians and people with disabilities, often collectively referred to as ‘active users’, are found in many locations. These bridges (refer Figure 1.1) can enhance personal mobility, improve community health and promote social equity. Compared to bridges carrying motorised traffic, the loads applied to active user bridges are relatively light. This offers opportunities for design innovations and can enhance the urban landscape aesthetic.

The available funding will never match the demand for socially valuable active mode bridges. Designers must address value-for-money considerations and whole-of-life factors to maximise the quantum and quality of infrastructure.

The principal objectives of this technical guideline are to:

- provide an overview of appropriate design references
- review life cycle cost factors affecting value-for-money outcomes, and
- identify cost saving opportunities and potential innovations.

**Figure 1.1 – A cyclist crossing a commuter cycle bridge on the Veloway 1 (V1), Brisbane**



## 1.2 Abbreviations

All acronyms or abbreviations used in this guideline are detailed in Table 1.2 below.

**Table 1.2 – Table of acronyms and abbreviations**

Item	Description
ABCB	Australian Building Codes Board
ABS	Australian Bureau of Statistics
ARI	Average Recurrence Interval
AS	Australian Standard
AS/NZ	Australian and New Zealand Standard
ASSHTO	The American Association of State Highway and Transportation Officials
ATS	Anti – Throw Screen
BCC	Brisbane City Council
BCR	Benefit Cost Ratio
Bridge Code	AS/(NZS) 5100:2017 <i>Bridge Design Code</i>
DETE	Queensland Department of Education, Training and Employment
ECC	Engineered Cementitious Composite
fib	International Federation for Structural Concrete
FRP	Fibre Reinforced Polymer
LRFD	Load Resistance Factor Design
MRTS	Transport and Main Roads Technical Specification
NCC	National Construction Code (Building Code)
PSC	Pre-stressed Concrete
QR	Queensland Rail
RC	Reinforced Concrete
RMS	NSW Department of Roads and Maritime Services
SCC	Sunshine Coast Council
SET	South-East Transit (Busway) Project
SLS	Serviceability Limit State
ULS	Ultimate Limit State
V1	Veloway 1, Brisbane

## 2 Design considerations

### 2.1 Design issues

When designing the elements of a pedestrian, cyclist or shared use bridge (refer Figure 2.1), a designer must consider:

- aesthetics
- design life
- collision risk and impact protection

- user envelope
- access requirements
- occasional vehicle access
- loads
- limit state criteria
- deflections
- dynamic behaviour
- anti-throw screens
- railings
- balustrades
- kerbs
- drainage, and
- bearings.

**Figure 2.1 – Elements of the pedestrian / cycle bridge**

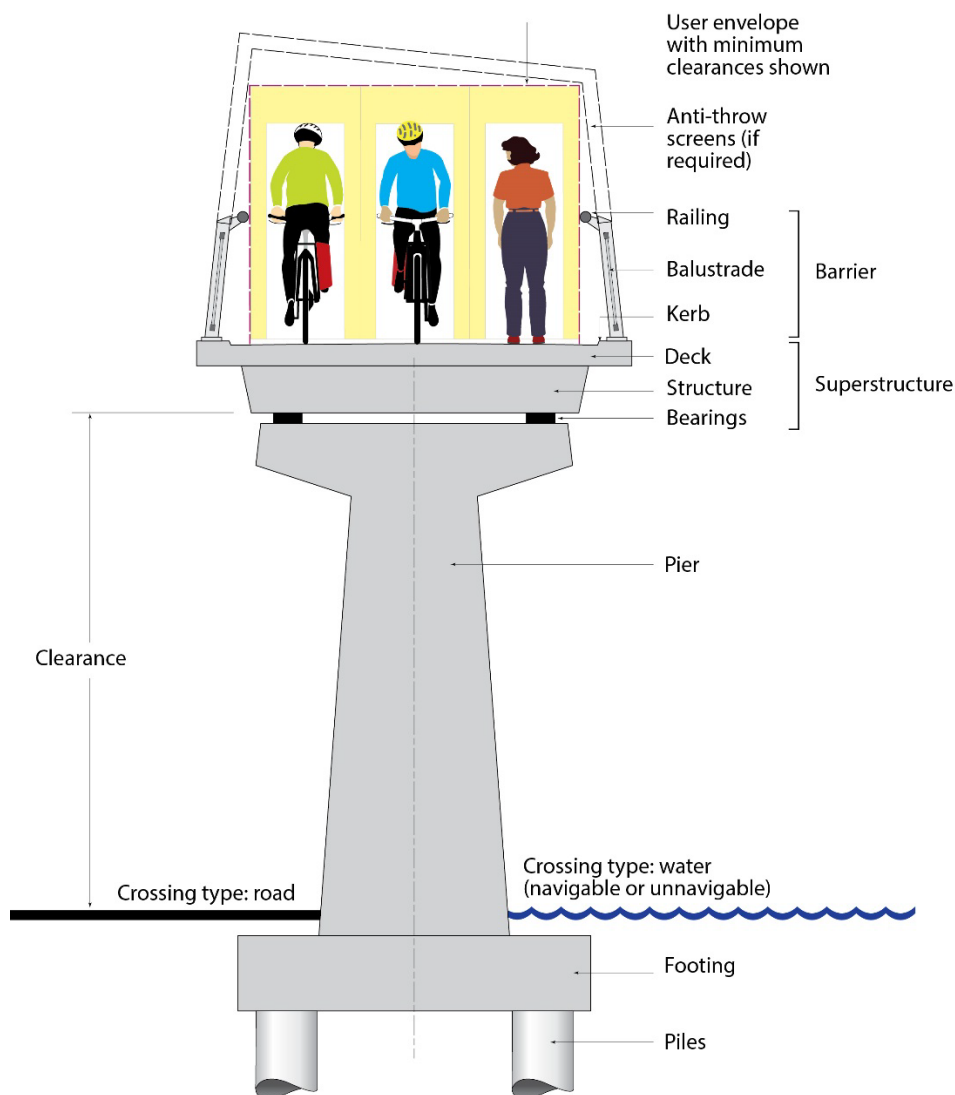

The designer must determine the most appropriate type of structure from the available options (girder, truss, arch, slab, or cable), and select the most suitable combination of materials (concrete, steel, aluminium, timber, or FRP). Prime considerations are durability and cost effectiveness.

These decisions will be influenced by the span(s) to be overcome. This often will involve consideration of several possible configurations and a comprehensive options analysis.

## **2.2 Crossing types**

Pedestrian and cycle bridges traverse a variety of obstacles, which can be broadly categorised as either waterway crossings or transport corridors.

Waterway crossings include bridges over creeks, canals, rivers (see Figure 2.2(a)), lakes, and coastal waters.

**Figure 2.2(a) – Kurilpa shared use bridge over the Brisbane River, viewed from the Bicentennial shared use bikeway and boardwalk**



Crossings over transport corridors include bridges over railways, freeways, highways, motorways, sub-arterial roads, and local streets (refer Figure 2.2(b)).

**Figure 2.2(b) – Goodna State School shared use bridge over the Ipswich rail line and Ipswich Road.**





Each crossing type has particular requirements that will influence the type of bridge option chosen. Inappropriate crossing types can have cost implications.

For example:

A shared use bridge over a local tidal creek with shallow banks requires access ramps on both sides of the crossing, to achieve the minimum navigable clearance from high water to the underside of the bridge.

If a deep precast PSC beam with an insitu concrete deck is chosen (refer Figure 2.2(c)), the elevation of the pathway will be raised considerably above the minimum requirement, possibly by more than a metre. The access ramps will consequently need to be made longer by up to 20 m on each side, with potential cost implications.

An alternative solution, which would lower the path level on the bridge and shorten the access ramps, could be a shallow precast concrete deck on a through truss or arch.

**Figure 2.2(c) – Shared use waterway crossing**



On the other hand, the concrete superstructure chosen may offer durability advantages over a steel truss or arch, unless the steel is galvanised, and could offer whole-of-life benefits. Perhaps, then, consideration could be given to provision of a concrete deck supported on the corbelled bottom flanges of two PSC beams. Such considerations must be considered in a robust options analysis to find the best value-for-money solution.

### **3 Cost considerations**

#### **3.1 Whole-of-life costs**

Value-for-money principles include analysis of:

- the initial costs of a bridge by the judicious sizing of elements and selection of materials

- maintenance requirements and costs (including unscheduled repairs), and
- overall operational life of the bridge.

Whole-of-life (or life-cycle) costs can therefore be classified into the three following expenditure categories:

- **Development** - the costs of planning, design, and procurement. This includes geotechnical and hydraulic investigations, tendering and evaluations up to award of a construction contract. Typically these costs can be 25% of overall project costs. It can be false economy to skimp on good planning and design, although serious attempts should always be made to ensure efficiency of resources.
- **Implementation** - the cost of constructing the works, including the value of the accepted tender, any variations during construction, the cost of project management and contract administration, and the value of expenditure for utility service relocations.
- **Operation** - the future cost of routine maintenance and major repairs, such as regular inspections, cleaning, repainting, etc. These costs are subject to the time value of money principle, where a dollar spent in, say ten years, has a lesser 'present value' than one expended today. The present value of that dollar diminishes as time goes on, determined by the discount rate, which is itself variable.

The bridge designer must analyse how the total present value of a bridge is impacted by the:

- design and development costs
- initial cost of construction
- any recurring routine maintenance costs, and
- discrete capital repair expenditures in the future.

To some extent, future expenditures are unknowable, although relativities do exist.

For example:

A painted steel bridge may need repainting in about 15 – 30 years (refer Section 24), depending on the quality of the initial application. A galvanised structure may last 50 years before requiring surface treatment. So, generally, a galvanised bridge will have a long-term advantage over the painted one. But the advantage may be less obvious if painting is initially cheaper than galvanising, and any future repainting could be achieved with relative ease.

The designer's twin objectives are to:

- minimise the initial cost of the bridge under consideration, and
- ensure that sufficient durability is built in, so that the present value of the bridge (and consequently its whole-of-life cost) is minimised.

The easiest way of ensuring value-for-money is to save money on a bridge's construction cost without jeopardising its long-term durability. A designer must also ensure that the form of construction allows ease of maintenance for the bridge's intended life.

### 3.2 Cost factors

The numerous factors that influence the cost of cycle and pedestrian bridges can be found in Table 3.2 below.

**Table 3.2 – Potential factors influencing the cost of cycle and pedestrian bridges**

Cost factor	Description	Reference
Aesthetic considerations	All bridges should be a positive addition to their surroundings. The effort (and expense) needed to be expended will depend on a bridge's prominence. The Kurilpa and Goodwill Bridges (across the Brisbane River) have received justified sensitive treatment. The same architectural attention on a less prominent bridge may not be appropriate.	Section 5
Strategic planning	Good planning is vital for the efficient provision of bridges for active modes, especially in constrained corridors. Retrofitting unplanned structures adds to the cost of construction.	Section 6.1
Strategy implementation	Equally important to good planning is a bridge's implementation, especially if construction of another transport facility precedes it. For example, widening of substructures can considerably ease the provision of a future active transport structure. Failure to make such allowances can substantially increase costs.	Section 6.2
Design options analysis	An economic evaluation of a constructed shared use bridge calculated a BCR of 0.3. A primary factor was <i>'the comparatively high capital cost'</i> . To ensure value-for-money, a designer must investigate a number of conceptual options. Options should, involve trial alignments, varying profiles, and different structure types.	Section 7.2
Delivery Options	Experience demonstrates that the contractual mechanisms chosen for design and construction can lead to improved value-for-money outcomes.	Section 7.3
Site constraints	Some bridge sites are inherently difficult, while others have been made so by previous infrastructure works or utility services. Overcoming adverse site constraints can add to construction costs, so a designer should identify all constraints and investigate ways to ameliorate them.	Section 8
Design life	The normal design life required of a bridge is 100 years. Few bridges will obtain this operational life, without intervention.	Section 9
User envelope selection	A wide bridge will always be more expensive than a narrower one of the same construction. This may not be a linear relationship. For example, a 3 m wide bridge may be more than 75% of the cost for a 4 m wide bridge, but a marginal cost will be paid for the additional width. It is important to consider what level of user utility is justifiable, when measured against value-for-money considerations.	Section 10
Vertical clearance	Pedestrian and cycle bridges are particularly exposed to vehicle impact. Their clearance over road, rail and navigable waterways should be sufficient to avoid this. Clearance requirements mean that designers must consider access imperatives, superstructure types, and span lengths.	Section 11.2



<b>Cost factor</b>	<b>Description</b>	<b>Reference</b>
Access imperatives	Usually a bridge will require walkways or ramps, for access to the grade separation. These can be as extensive as the bridge itself, and equally expensive. The most cost effective arrangement must be sought. This can have ramifications when choosing the most appropriate span lengths and structure types, especially when combined with clearance imperatives.	Section 12
Material selection and durability	A wider range of material is available for pedestrian and cycle bridges than for road bridges. As reinforced and prestressed concrete are the most familiar materials to road bridge designers, they are often used for pedestrian and cycle structures. But alternatives may offer cost advantages. Only materials with low corrosivity, or materials treated to achieve low corrosivity should be selected. Materials that can degrade or be easily damaged should be avoided in certain circumstances. A material that has low corrosivity, and is non-degradable, will however be of little application in a secluded location if it is flammable and a vandalism risk. An initially inexpensive bridge, which subsequently degrades or is damaged, vandalised, or otherwise found unfit for purpose, will not ultimately offer value-for-money.	Section 13
Bridge type selection	There are many types of bridges for pedestrians and cyclists, and the structural system chosen should reflect the site requirements. Creating narrow versions of road bridges should be balanced by considering other options suited specifically for active modes.	Section 14
Deck type selection	Except for metal bridges, the material selected for a deck tends to follow the structure supporting it. For example, FRP bridges have polymer or plastic decks, concrete girders support concrete decks. There is no consensus about how best to configure decks, particularly concrete ones, where many options exist.	Section 15
Span lengths	There is a preference to maximise span lengths, as this can be an aesthetic consideration. A long clear span will generally be more visually appealing than several short spans cluttered with piers. Also, a long span may be selected to avoid building a pier within the clear zone. To sustain collision loads, a pier may need to be overly robust in relation to the, less severe, normal structural demands of pedestrian and cyclist loads. Alternatively, a long span may raise the height of a bridge, with an adverse effect on the length of approach spans. This can be a balancing act, which needs careful consideration.	Section 14.2
Vehicle access	Occasional vehicle access is frequently overlooked. This can lead to bridges becoming unfit for purpose, especially in park surroundings (e.g. where a tractor mounted mower may be expected to operate across a bridge). Equally, relatively heavy maintenance vehicles can be unrealistically anticipated, with considerable impact on cost.	Section 16
Load definition	Live loads for pedestrians and cyclists generally lie within the range 4 – 5 kPa. Opportunities to apply the lower bound of that envelope should be investigated. Bridges should be designed for an occasional vehicle load and conflicting requirements for wheel load definition can significantly impact on the cost.	Section 17

<b>Cost factor</b>	<b>Description</b>	<b>Reference</b>
Collision Impact	Pedestrian and cycle bridges lend themselves to gracefully slender columns. These are not compatible with the onerous collision loads specified in design standards, which generally require very substantial piers. Designers need to balance these competing influences and configure pier locations in the most cost effective manner.	Section 18
Serviceability	The dynamic response of a bridge and its propensity to deform under load should be kept within reasonable limits. Attempts to refine a bridge can render it so light that expensive measures are required to reduce its propensity to vibrate. Also some materials are inherently more susceptible to deformation than others.	Section 19
Barrier arrangements	Posts, rails and balustrades serve an important safety function. They can also improve the visual impact of a bridge, although bespoke handrails will generally cost more than prosaic possibly proprietary products. In less prominent locations, value-for-money will often be served by simplicity and practicality. Barriers can also be affected by occasional vehicle considerations, theft and vandalism.	Section 20
Drainage	Stormwater must be efficiently shed from bridge decks. Options to be considered include cross-fall, scuppers, kerbs, or more complex drainage works.	Section 21
Anti-throw screens	Anti-throw screens will invariably add cost to a bridge. They should only be installed where a formal risk assessment indicates them necessary.	Section 22
Foundations	Foundations for pedestrian and cycle bridges normally comprise high level spread footings or pile footings. Because of the relatively light loads imposed on foundations by these bridges, smaller foundations than would apply to a road bridge may be appropriate.	Section 23
Ease of maintenance	A key factor in minimising future costs is the facility of the bridge for maintenance activities. Any difficulty accessing bearings, or painting over busy transport corridors, for example, should be anticipated by the designer.	Section 24

The impact of these factors will vary from bridge to bridge. Some, such as difficult site constraints or the need for substantial access works, can be unavoidable. Others, like poor structure selection or excessive user envelope provision, can impose excessive costs that might be more usefully employed on additional infrastructure.

It is important to understand why some bridges can be constructed at costs per usable m<sup>2</sup> that are considerably lower than others. In this context, the term 'usable m<sup>2</sup>' denotes the area of bridge defined by its length and the width between railings.

Where actual monetary costs are quoted for comparison purposes, they are generally current costs, unless noted otherwise. These are calculated from the Australian Bureau of Statistics (ABS) *Index Number: 3101, Road and Bridge Construction, Queensland*, which provides cost indices from September 1998 to March 2017.

For example:

Converting the 1998 construction cost of the Jack Pesch Bridge (refer Section 7.3) in Indooroopilly, to current costs has involved using a multiple of 1.92 (107.8/56.1).

## 4 Design references

### 4.1 General

Bridge design is carried out under regulated standards, established criteria and accumulated professional practice. It is useful to provide an overview of that knowledge base before proceeding to a more detailed discussion of whole-of-life issues for pedestrian and cycle bridges.

Within Queensland the design of cycle and pedestrian bridges is currently controlled by a variety of overlapping codes, manuals, standards and guidelines. These are not always consistent.

The principal sources for the available design references are:

- Bridge Design Code (refer Section 4.2)
- Austroads (refer Section 4.3)
- Agency Criteria (refer Sections 4.4 – 4.8)
- Australian Standards (refer Sections 4.9)
- Australian Building Codes (refer Section 4.10), and
- Industry publications (refer Section 4.11).

Several agencies, with responsibility for the provision of bridges, maintain supplementary criteria, which modify national bridge design guides to take account of local conditions or preferences.

Principally these agencies are:

- Transport and Main Roads
- Queensland Rail
- Brisbane City Council, and
- Regional local authorities.

The principal reference for good bridge design practice on the department's network is the *Design Criteria for Bridges and Other Structures* manual. That document is primarily intended for design of bridges on the network that are constructed to accommodate motorised vehicles. Consequently, some of its requirements can appear onerous when applied to bridges principally intended for pedestrians and cyclists. Some recommendations contained in this technical guideline, for example foundations (Section 23), may suggest non-compliant solutions, with respect to the department's Bridge Design Criteria, which does not comprehensively cover pedestrian and cycle bridges. Where designers propose to adopt bridge features that do not conform to the requirements of the Bridge Design Criteria, they should seek approval to do so at an early stage in the bridge fixing process, as discussed in Section 4.4.1.

Table 4.1 shows the various design guidance documents referred to in this document.

**Table 4.1 - Referenced documents**

<b>Reference</b>	<b>Title</b>
AASHTO 2009	<i>Guide for the Design of Pedestrian Bridges</i>
AASHTO	USA National Bridge Design Code <i>LRFD Bridge Design Specification</i>
AS 1170	<i>Structural Design Actions</i>
AS 1428	<i>Design for Access and Mobility</i>
AS 2156:2001	<i>Walking Tracks</i>
AS/NZS 2312	<i>Guide to the protection of structural steel against atmospheric corrosion by the use of protective coatings</i>
AS/NZS 3661	<i>Slip resistance of pedestrian surfaces</i>
AS/NZS 4680	<i>Hot dipped galvanized (zinc) coatings on fabricated ferrous articles</i>
AS 5100:2004*	<i>Bridge Design – Superseded Edition</i>
AS/(NZS) 5100:2017	<i>Bridge Design – Current Edition (the Bridge Code)</i>
ATS Policy	<i>Policy for Reduction of Risk from Objects Thrown from Overpass Structures onto Roads, Transport and Main Roads</i>
ATS Guidelines	<i>Technical guidelines for treatment of overhead structures – objects thrown or dropped, Transport and Main Roads</i>
Bridge Design Criteria	<i>Design Criteria for Bridges and Other Structures, Transport and Main Roads</i>
DETE:3.0	<i>Design Standards for DETE Facilities</i>
MRTS63A	<i>Piles for Ancillary Structures</i>
MRTS70	<i>Concrete</i>
MRTS78	<i>Fabrication of Structural Steelwork</i>
NCC	<i>National Construction Code, Part 1 (the Building Code)</i>
Austrroads Part 6A	<i>Austrroads Guide to Road Design: Part 6A - Pedestrian and Cyclist Paths</i>
RPDM Part 6A Supp	<i>Supplement to Austrroads Guide to Road Design Part 6A: Pedestrian and Cyclist Paths</i>
Part 13*	<i>Austrroads Guide to Traffic Engineering 1999 : Part 13 - Pedestrians</i>
Part 14*	<i>Austrroads Guide to Traffic Engineering 1999 : Part 14 - Cyclists</i>
RPDM	<i>Road Planning and Design Manual, Transport and Main Roads</i>
Standard Drawing 2021	<i>550 Octagonal PSC Piles – Earthquake classification BEDC-1, Exposure classification B2</i>
-	<i>Federal Disability Discrimination Act</i>

Note \* Denotes superseded document.

#### **4.2 Bridge Design Code**

The principal design reference for all bridges in Queensland is the Australian Standard, AS/(NZS) 5100:2017.

Some references may refer to the superseded version of the Bridge Code, AS 5100:2004.

### **4.3 Road association guides**

Austrroads publishes the *Guide to Road Design Part 6A: Pedestrian and Cyclist Paths*. The department has generally accepted this document, with some amendments contained in a supplement (refer to Section 4.4.2 of this guideline).

The now superseded Austrroads series *Guide to Traffic Engineering* (1999) contained two separate parts that covered cyclists and pedestrians, namely:

- Part 13 - *Pedestrians*, and
- Part 14 - *Cyclists*.

While the purpose of Part 6A in the current Austrroads guide is to replicate the superseded Part 13 and Part 14, the older documents are still frequently referenced in design guides.

### **4.4 Queensland Department of Transport and Main Roads**

#### **4.4.1 Design Criteria for Bridges and Other Structures**

The department maintains supplementary design guidance to augment the national *Bridge Design Code* (see Section 4.2 above), namely its manual *Design Criteria for Bridges and Other Structures*. The latest version of the Bridge Design Criteria still relates to the superseded, 2004 version of the *Bridge Design Code* (AS 5100). This reference will eventually be updated.

This manual is predominantly intended for designers of road bridges carrying motorised traffic, and its provisions can appear overly robust when applied to pedestrian and cycle bridges.

Permission to use alternative criteria should always be sought early in the design process (refer Section 4.1).

#### **4.4.2 Road Planning and Design Manual (RPDM)**

In this manual, the department maintains a Supplement to Austrroads *Guide to Road Design Part 6A: Pedestrian and Cyclist Paths* (refer Section 4.3).

#### **4.4.3 Technical notes**

Transport and Main Roads has prepared a series of Technical Notes for specific guidance in design issues. Several relate to pedestrian and cycle bridge design issues, namely:

- TN49 *Theft Proofing of Aluminium Bridge Rail and Balustrade*
- TN54 *Fibre Composite Projects*
- TN131 *Shared Path and Bicycle Path Termination Treatments*
- TN133 *Guidance on the Widths of Shared Paths and Separated Bicycle Paths*
- TN144 *Paint Systems for MRTS88*
- TN146 *Long Term Maintenance Issues for Bridges*.

This is not a comprehensive list of the department's Technical Notes. A full listing is available at:

[www.tmr.qld.gov.au/business-industry/Technical-standards-publications/Technical-Notes](http://www.tmr.qld.gov.au/business-industry/Technical-standards-publications/Technical-Notes)

#### **4.4.4 Transport and Main Roads Specifications**

The department maintains a series of Technical Specifications for the purposes of defining minimum standards of construction. Knowledge of these is a necessary requirement in bridge design. These can be viewed at:

[www.tmr.qld.gov.au/business-industry/Technical-standards-publications/Specifications](http://www.tmr.qld.gov.au/business-industry/Technical-standards-publications/Specifications)

The Bridge Design Criteria states that these Technical Specifications ‘are conscious decisions of the department’s structural engineers to provide long service life and minimum whole-of-life cost’.

#### **4.4.5 Standard drawings**

Transport and Main Roads maintain a series of Standard Drawings, which can be useful in bridge design when applying commonly used construction elements. These can be viewed at:

[www.tmr.qld.gov.au/business-industry/Technical-standards-publications/Standard-drawings-roads](http://www.tmr.qld.gov.au/business-industry/Technical-standards-publications/Standard-drawings-roads)

#### **4.4.6 Miscellaneous guidelines**

The department has issued the following policy and companion technical guidelines regarding Anti-Throw Screens.

- *Technical guidelines for treatment of overhead structures – objects thrown or dropped* (ATS Guidelines).
- *Reduction of Risk from Objects Thrown from Overpass Structures onto Roads* (ATS Policy)

<https://www.tmr.qld.gov.au/business-industry/Technical-standards-publications/Report-on-testing-vehicle-windcreens>

#### **4.5 Queensland Rail (QR)**

QR maintains a series of Civil Engineering Technical Requirements. The following relate to the design of pedestrian and cycle bridges over and adjacent railways:

- CIVIL-SR-002 *Work in or about Queensland Rail Property*
- CIVIL-SR-006 *Design of Footbridges*
- CIVIL-SR-007 *Design and Selection Criteria for Road / Rail Interface Barriers*
- CIVIL-SR-008 *Protection Screens*, and
- CIVIL-SR-012 *Collision Protection of Supporting Elements adjacent to Railways*.

The department’s Bridge Design Criteria (refer Section 4.4.1) also references bridges over and / or near railways, and amends CIVIL-SR-007.

#### **4.6 Brisbane City Council (BCC)**

BCC’s conditions for the design of bridges are contained in the City Plan available at: <http://eplan.brisbane.qld.gov.au/>. The relevant chapter can be found by following the links > Schedule 6 > Planning Scheme Policies (PSP) > Infrastructure Design PSP > Chapter 8 Structures.

#### **4.7 Regional local authorities**

From time to time, Regional Local Authorities issue requirements for the design and / or construction of pedestrian and cycle bridges within their jurisdictions.

#### **4.8 Queensland Department of Education, Training and Employment**

School students often require special consideration. Where use by significant volumes of children are anticipated, a useful reference is *Design Standards for DETE Facilities* (DETE:3.0).

The DETE requirements may be viewed at:

<https://det.qld.gov.au/det-publications/standards/Documents/design/design-standards-dete-facilities.pdf>

#### **4.9 Australian Standards**

##### **4.9.1 Introduction**

Several Australian Standards, other than AS(/NZS) 5100 (refer to Section 4.2), are often referenced in design of pedestrian and cycle bridges. Documents particularly address loads, access for mobility impaired users, and slip resistance.

##### **4.9.2 Loads**

- AS 1170 – *Structural Design Actions*
- AS 2156:2001 - *Walking tracks* (for recreational facilities in a natural outdoor setting).

##### **4.9.3 Access for users with a disability**

- AS 1428 - *Design for access and mobility*.

##### **4.9.4 Slip resistance**

- AS/NZS 3661.2 – *Slip resistance of pedestrian surfaces; Part 2: Guide to the reduction of slip hazards*
- AS 4586 – *Slip resistance classification of new pedestrian surface materials*, and
- AS 4663 – *Slip resistance measurement of existing pedestrian surfaces*.

#### **4.10 Australian Building Codes Board (ABCB)**

The ABCB produces the *National Construction Code (NCC)*. Part 1 comprises the *Building Code of Australia* for Class 2 to Class 9 Buildings (the Building Code), which includes design criteria for stairs. The Bridge Code references the NCC in this respect.

#### **4.11 Industry publications**

Organisations are often formed to promote particular technologies. An example is the *International Federation for Structural Concrete (fib)*, which has published a guide for the design of footbridges, with information pertinent to cycle / pedestrian bridges.

## **5 Aesthetics**

An elegant bridge is always preferable to more prosaic alternatives. Good design practice should always be followed to avoid visually disfiguring the environment. The main principles of bridge aesthetics are introduced in Chapter 2 of the Bridge Design Criteria. A more detailed consideration is provided in *Bridge Aesthetics: Design guideline to improve the appearance of bridges in NSW*, design guidance issued by the NSW Roads and Maritime Services Agency (RMS). In that guideline, a comprehensive list of other references on the subject of bridge aesthetics is also provided.

For example:

Circa 2007 when Griffith University needed to link its Gold Coast campus across Smith Street, it chose a cable stay structure refer (Figure 5(a)) with a dramatically inclined tower. The bridge incorporates the university's colours and logo, and provides a signature statement.

**Figure 5(a) – Griffith University shared use bridge, Gold Coast**



Pronounced aesthetic considerations can, however, lead to additional cost. Where a bridge is highly visible this may be justified, but in less prominent locations a simpler design might be more appropriate.

For example:

In the case of the Moggill Road cycle bridge in Indooroopilly (refer Figure 5(b)), its nine distinct spans vary from 14 to 32 m. The Bridge Design Criteria recommends that bridges ‘present smooth, clean lines’, and, as can be seen, the depth of the girders was kept uniform to satisfy this aesthetic aim.

**Figure 5(b) – Moggill Road cycle bridge, Indooroopilly**





On the other hand, the Bridge Design Criteria also notes that girders should ‘have a minimum depth consistent with their spans’. So, from a structural perspective, the shorter spans could have been shallower, and therefore potentially less expensive to fabricate, transport and erect. Uniformity can be justified in this case, on the basis of the bridge’s relatively high visibility, but this decision would have added to the cost.

An important decision, with all pedestrian and cycle bridges, is whether anti-throw screens are necessary (refer Section 22). Anti-throw screens can present aesthetic challenges, as they tend to create bulky looking structures, and require sensitive treatment. The provision of anti-throw screens will always add cost to a pedestrian or cycle bridge, and they should not be adopted arbitrarily. If they are considered necessary following the risk procedure (refer Section 22), some attempt should be made to soften their visual impact. Anti-throw screens were not provided at Moggill Road (refer Figure 5(b)), a decision taken after the appropriate risk analysis. This allowed the bridge to show a uniformly graceful railing profile. An anti-throw screen would have created aesthetic issues. The balustrade design was, however, configured in such a way that anti-throw screens can easily be retrofitted in the future, if necessary.

For example:

The pier at Tank Street in Brisbane, for the Kurilpa Bridge (refer Figure 5(c)) has been elegantly proportioned, in keeping with its high visibility to commuters on North Quay. This attention to detail, requiring site specific formwork, might not, in a value-for-money sense, be justified at a less prominent location.

**Figure 5(c) – Kurilpa Bridge pier, Tank Street, Brisbane**



## 6 Planning

### 6.1 Strategic planning

Ideally, a pedestrian and / or cycle bridge will be the ultimate outcome of a coordinated strategic route plan. Any preceding infrastructure should be carefully executed to allow efficient implementation of the pedestrian / cycle bridge scheme.

For example:

When the Pacific Motorway was being upgraded during the 1990s, provision for cycling was not included. Consequently, this made providing future cycleway bridges along this corridor extremely difficult.

Some years later, when the South-East Transit (SET) busway project was adopted, a future upgrade of the V1 was included in the overall planning. An extract from the 1997 planning layout for the proposed cycle bridge at Juliette Street, Greenslopes is shown in Figure 6.1. The busway was constructed circa 2000 and construction of the cycle bridge was commenced 16 years later. It was completed in mid-2017, essentially on the planned alignment.

**Figure 6.1 – SET planning layout for Juliette Street cycle bridge**

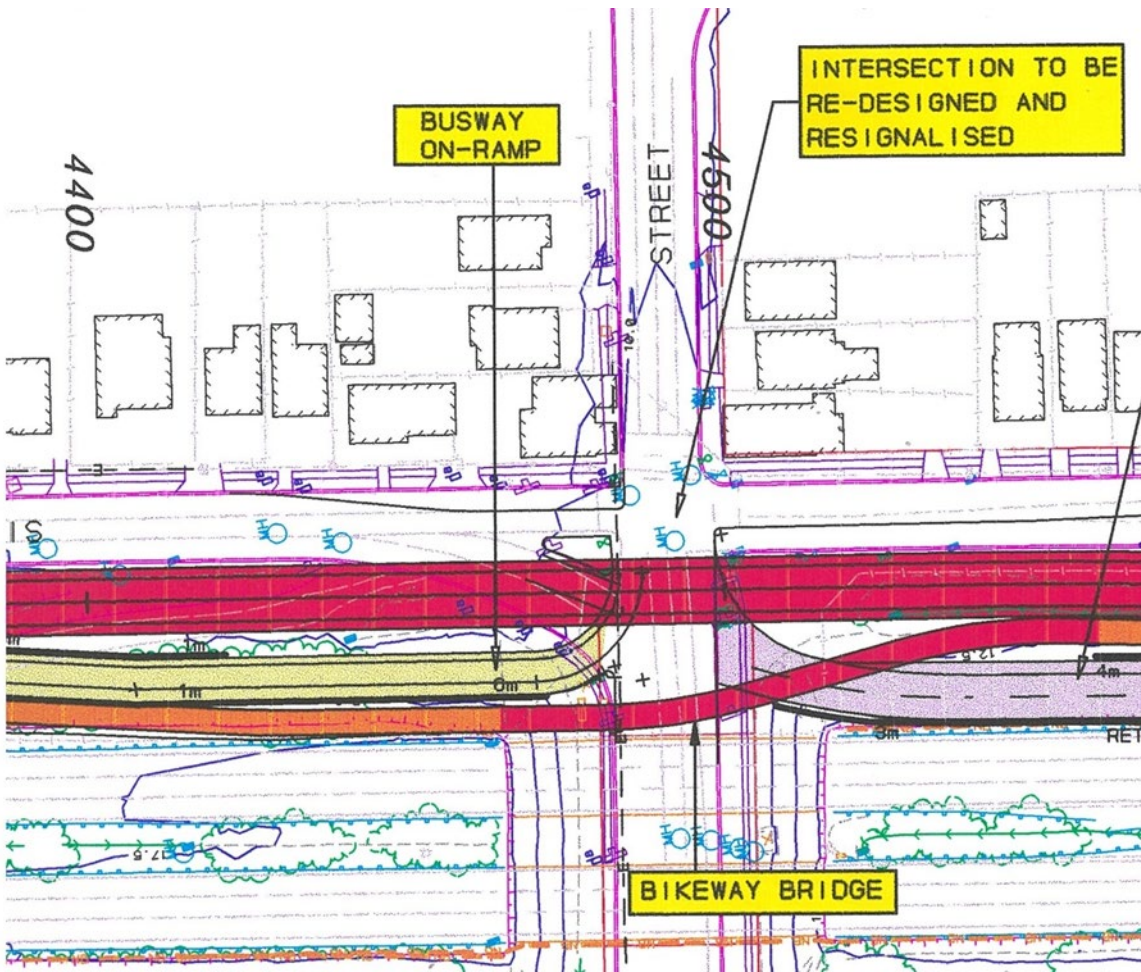

The planning layouts reserved the site for a future cycle bridge, although the construction of the busway introduced some constraints for the cycle bridge scheme (refer Section 6.2). Decisions made during the original project impacted on delivery of the cycle bridge a decade and a half later.

Providers of all transport infrastructure should review the Principal Cycle Network Plans to determine their potential impact on possible future cycle bridges. Provision should be made where necessary. The plans are available at:

[www.tmr.qld.gov.au/Travel-and-transport/Cycling/Principal-Cycle-Network-Plans](http://www.tmr.qld.gov.au/Travel-and-transport/Cycling/Principal-Cycle-Network-Plans)

## 6.2 Implementation

When strategic planning allows for a future active transport route, prior infrastructure construction should be built in a way that does not hinder future work.

More proactively, this can involve widening substructures (refer Figure 6.2) to accommodate the future bridge's superstructure. (Planning revisions can, occasionally, supersede such allowances).

**Figure 6.2 – Widened substructure to enable future erection of superstructure**



The planning layouts developed for the SET project, circa 1998, allowed a corridor for a future bikeway (refer Section 6.1). When the SET works were constructed, some bridge abutments were widened to suit future cycle bridges. For Juliette Street (refer Figure 6.1) the southern abutment had been widened. This partially facilitated the eventual construction of the cycle bridge, although the other abutment was not constructed. Pier headstocks were also not widened, which introduced complexity to the eventual cycle bridge construction with cost implications.

About nine of the cycle bridges envisaged by the SET planning have now been constructed. Costs have been considerably greater than if future cycle infrastructure had been considered more carefully during implementation of the initial project (refer Section 8).



## 7 Options analysis

### 7.1 General

Each bridge should undergo a comprehensive options analysis to determine the most appropriate location and configuration of spans, structure type, material, and access opportunities.

Numerous options are available for construction contract methodologies. The choice of delivery mechanism can also significantly impact on value-for-money outcomes.

While the 'best' solution is difficult to ascertain, there are always 'wrong' options which the designer can avoid.

Two real project examples illustrate both the process and its inherent difficulties.

### 7.2 Design options

The final design for the Toowong Crossing, from Anzac Park to Mt Coot-tha Road (refer Figure 7.2(a)) was selected by a process that included:

- preparing separate estimates for concept designs at four different sites, and
- assessing the advantages and disadvantages of each one, including cost.

**Figure 7.2(a) – Toowong crossing over Western Arterial and bikeway**



At the finally chosen site, several competing structural systems were investigated. This included the cable stay option shown in Figure 7.2(b), which was eventually discarded for foundation reasons, as the material encountered in the geotechnical investigation did not favour the asymmetric configuration.

Steel was chosen for the girders, as the ramps and a portion of the grade separation were tightly curved.

Figure 7.2(b) – Concept design for Toowong Crossing during Options Analysis

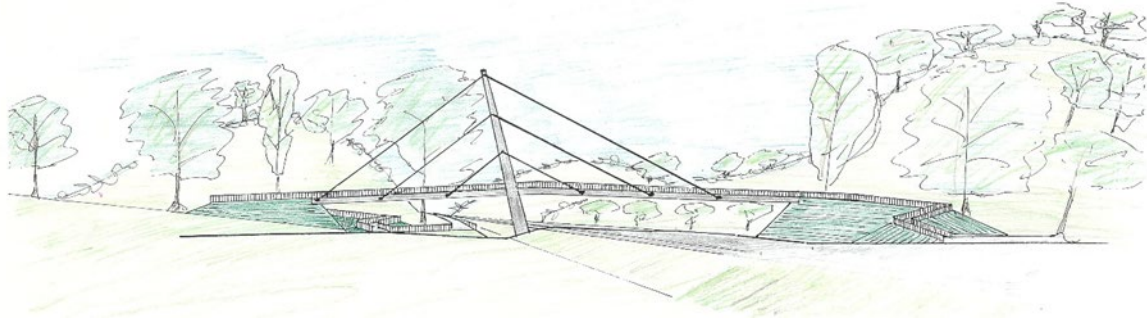

### 7.3 Delivery options

The Jack Pesch Bridge over the Brisbane River at Indooroopilly (built in 1998) illustrates the need to always consider delivery mechanisms.

The original design was a four span cable stay bridge with a central pier in the river. This pier was to align with the existing central pier of the adjacent Albert Rail Bridge (refer Figure 7.3(a)).

Figure 7.3(a) – Jack Pesch Bridge – original design

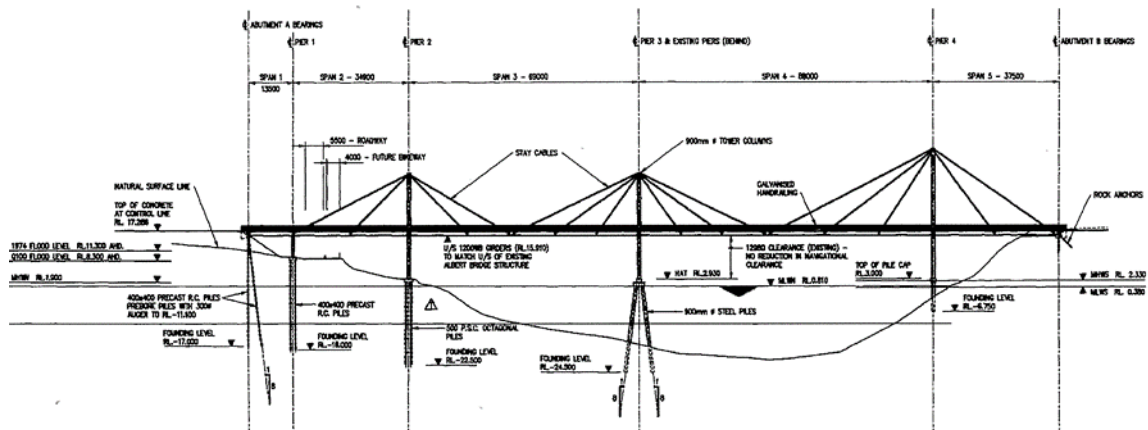

When invitations to tender for construction were called, the conditions of tendering included the ability to offer alternative designs. The successful contractor offered a three span cable stay bridge solution that avoided the central pier (refer Figure 7.3(b)).

Figure 7.3(b) – Jack Pesch Bridge – final design

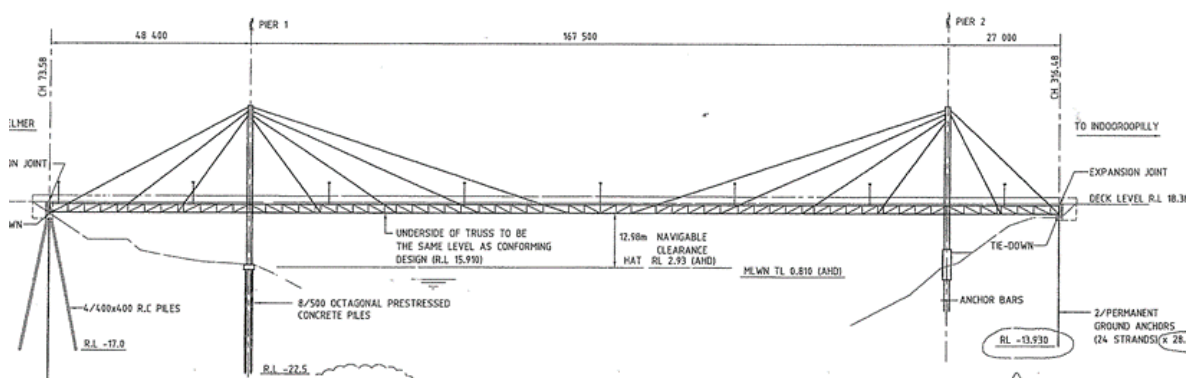

The tender price for the alternative was 15% less than the conforming price the Contractor offered for the original design. This resulted in a saving of over \$1M at current values. The original bridge type (and many of the ancillary items from the original design) were retained (deck, balustrades and the like). The concept of a cable stay solution and its essential detailing were sound. It was a good option, although not the best value-for-money solution when exposed to commercial scrutiny.

This example demonstrates the benefits of maintaining a flexible approach to contract delivery mechanisms, to take full advantage of possible innovations. This principle is reinforced in Section 14.6.3, where a design and construct delivery process yielded similar value-for-money benefits.

## **8 Site constraints**

All pedestrian and cycle bridges result from a need to grade separate some obstacle to efficient movement and that obstacle will in itself form a constraint.

Unless a cycle bridge is constructed on a green-field site, or the bridge-site has been embargoed by careful strategic planning (refer Section 6), the need to retrofit the bridge around adjacent transport infrastructure can introduce other constraints.

The principal site constraints affecting value-for-money include:

- alignment restrictions imposed by adjacent infrastructure
- adjacent property constraints
- adverse terrain
- poor geotechnical conditions
- roadside barriers
- limited pier support opportunities
- imposed span lengths
- noise barrier conflicts
- traffic management requirements during construction
- public utility restrictions and relocations
- enforced night time work during construction, and
- works area congestion during construction.

These additional constraints can often considerably increase the extent of the bridge, and / or its approach works. This may inflate the overall scope of works, leading inevitably to increased costs.

An example of alignment restrictions leading to a more expensive solution is the proposed Birdwood Road cycle bridge on the V1 at Greenslopes in Brisbane (refer Figure 8(a)) for design concept). A lack of support opportunities, a legacy of previous busway infrastructure works (refer Section 6.2), has resulted in the need for a span of 72 m. This has reduced the most practical option to a cable stay configuration, with substantial financial consequences.

**Figure 8(a) – Design concept for Birdwood Road cycle bridge**

Another example is the Bulimba Creek cycle bridge on the V1, at Eight Mile Plains (see Figure 8(b)). The bridge, constructed in 2010, was sited beneath a high voltage electricity line. In addition, a suitable founding level could only be found at depth so piling was necessary. The electricity transmission authority specified a mandatory clearance between the cables and any construction plant. This restricted the choice of pile driving equipment, and resulted in a need to splice all the piles every 5 m, resulting in significant cost impacts.

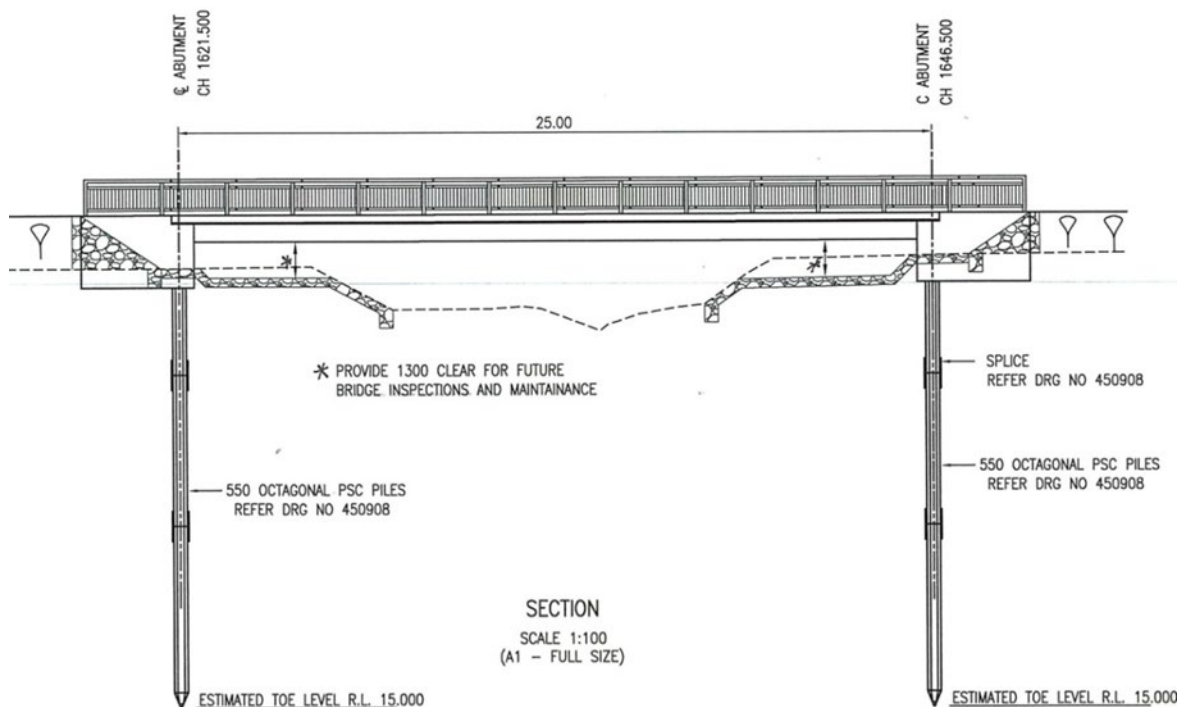
**Figure 8(b) – Bulimba Creek bridge, Eight Mile Plains**



In current day values, the bridge cost \$620,000 (\$8,265 / usable m<sup>2</sup>). The cost of the spliced pile foundations amounted to half that sum, significantly above the cost of unrestricted pile driving had this been possible. Although realignment options were limited, this additional expense might have been avoided if considered more carefully during planning.

A final example is the Moggill Road cycle bridge (refer Figure 5(b)), which was unavoidably constructed over a busy road and adjacent to a multi lane off-ramp to the Western Freeway. Provision for traffic at the site cost almost a million dollars or 15% of the construction cost.

This illustrates the need to identify all site constraints at the beginning of the planning and design process, so cost impacts can be reduced where possible.

## 9 Design life

The Bridge Code, the Bridge Design Criteria, and BCC's Planning Scheme (refer Section 4.6) all nominate 100 years as the operational design life for most bridges elements, without major maintenance or replacement. Few bridges in Brisbane, for example, are currently older than 85 years.

Although significant bridges should be designed for a 100 year design life, consideration might be given to adopting a lesser design life, say 50 years, where inbuilt longevity may be overrun by future developments.

In 1975, the bridge design office of Queensland Rail (QR) was briefed to provide a temporary pedestrian bridge over Central Station, in Brisbane, connecting Wickham Terrace to Ann Street. At the time, rapid redevelopment of the area was taking place, with major modifications to Central Station and the adjacent Turbot and Creek Streets. An air space development over the eastern end of the station was expected in the near future. It was thought the bridge would only be temporary. More than 40 years later it is still there (refer Figure 9).

**Figure 9 – Pedestrian bridge over Central Station, Brisbane**





The trusses were fabricated from galvanised CHS sections, with welded joints, and the deck was formed from precast reinforced concrete planks. Sufficient routine maintenance has been carried out over the years, principally involving:

- painting of welded joints
- surface treatments to the precast deck, and
- replacement of deck joint cover plates.

No major refurbishments have been made, although the galvanising is showing its age in places. Continuing regular routine maintenance will assist longevity of the bridge.

The key to ensuring design life, therefore, appears to be:

- selection of durable materials
- a bridge configuration that enables ease of maintenance, and
- completing maintenance on a regular basis.

For example, a painted steel bridge may have an operational design life of 100 years even though the paint finish only has a nominal life of 15 – 30 years. Consideration, then, must be given to how easily repainting can be achieved (refer Section 24). Other protective surfacing, like galvanising, will last longer but cannot be guaranteed to last 100 years.

## 10 User envelope

### 10.1 General

Adopting a suitable cross section is a primary task in the design of any cycle / pedestrian bridge design. This will involve determining a width, generally defined between handrails. Where the bridge is to be roofed (refer Figure 10.1) or enclosed, a minimum internal vertical clearance is required. The combination of these two parameters - width and height - defines the user envelope (refer Figure 2.1). This will vary widely depending on the type and extent of anticipated use.

**Figure 10.1 – Goodwill Bridge, Brisbane**



## 10.2 Width

In determining the width of a bridge, designers should consider the possible usage combinations. This is relatively simple for bridges designed exclusively for either cyclists or pedestrians. For shared use facilities it becomes more complex as the various streams of traffic are moving at different speeds.

The department's Bridge Design Criteria reflect the provisions of the superseded edition of the Bridge Code (AS 5100:2004), and makes a separate distinction between pedestrians and cyclists.

For pedestrians only the Bridge Design Criteria allows a minimum clear width between handrails of 1.8 m. A situation where only pedestrians are considered is now rare.

For dual use facilities (two way bicycles and pedestrians) and separated bikeways, the minimum width in the Bridge Design Criteria is 3.0 m. The Bridge Design Criteria also allows for a minimum width of 2.0 m on a low-volume one-way cycle way, although such a bridge would also be rare. The Bridge Design Criteria contains a figure defining these widths incorporated in a road bridge.

Normal practice on the department's commuter cycle network is to provide a minimum width of 3.0 m. This standard has been influenced by various design criteria. For two-way bicycle paths on bridges the minimum width required by the old Bridge Code (AS 5100:2004) was 3.0 m. Similarly, the now superseded Austroads Part 14 (refer Section 4.4) also suggested that any new bridge for cyclists should have a minimum clear width of 3.0 m. However, Part 14 allowed a compromise width of 2.0 m:

- for the use of existing structures where demand is low, or
- cycle speeds are reduced, or
- the predominant direction of traffic at peak times is in one direction.

The superseded Bridge Code (AS 5100:2004) also allowed a minimum width of 2.0 m for one way cycling.

The current Bridge Code AS(/NZS) 5100:2017 has dropped any reference to a specific minimum width for either cycling or shared use bridges. It has retained the minimum width of 1.8 m for pedestrian bridges. A specified '*matter for resolution before design commences*' in the code is '*Approval of cyclist path width...*', so the importance of the issue is not diminished. The latest Bridge Code defers to Part 6A (refer Table 4.1 in this guideline), '*subject to the approval of the relevant authority*'.

Part 6A itself is not specific for bridge widths. It recommends '*a path of adequate width, the choice depending on the characteristics of users and demand.*' This leads designers to the discussion of width in Section 7.5 and Appendix A of Part 6A.

In the *Road Planning and Design Manual* (RPDM), the department maintains a supplement to Part 6A (Part A Supplement - refer Table 4.1 and Section 4.4.2 in this guideline). The supplement prescribes a process for path width determination controlled by an assessment of peak hour pedestrian and cyclist volumes, and their directional split. Charts are available in the supplement that relate these parameters to path width. These charts are based on a level of service indicator, being a cyclist travelling at an average speed of 23 km/hr, who is delayed no more than 12 times an hour. On average, therefore, such a cyclist will be delayed approximately once every 2 km, so the probability of being delayed on even a 100 m long bridge is quite low.

While it is desirable that bridge widths align with approach path configurations, this may lead to expensive bridge structures that could be narrower (and cheaper) without materially affecting user utility. Site specific application and consideration of conditions is essential.

Despite minimum standards, the width adopted will be a function of the anticipated traffic. As additional width means additional costs, arbitrary allocations should be avoided: for example the Kurilpa Bridge and the Goodwill Bridge, which link each end of the CBD to South Brisbane, are 6.5 m between handrails. Both bridges are heavily trafficked by cyclists and pedestrians. The Schulz Canal Bridge is 4.5 m wide, the Jack Pesch Bridge at Indooroopilly is 4.0 m wide, while the Toowong Crossing overpass has a width of 3.5 m. These are all shared use bridges and there appears no uniform rationale behind the selection of these widths. Decisions are made on a project-by-project basis, so should always be scrutinised to ensure value-for-money.

All the bridges on the V1 along the Pacific Motorway in Brisbane are generally 3.0 m wide between handrails. These bridges are exclusively for cyclists.

### **10.3 Height**

Where a pedestrian or cycle bridge is covered by shade canopies or anti-throw screens, the height between the deck surface and the underside of the roof structure must be selected. This requirement also applies when a through truss is the adopted bridge type.

The Bridge Code suggests a minimum vertical clearance for cyclist and shared paths of 2.7 m. Austroads Part 6A only requires a minimum internal clear height of 2.5 m. This is based on a bicycle design envelope height of 2.2 m and a minimum allowance for clearance of 0.3 m.

The clear height should always be consistent with the anticipated traffic on the bridge, and the possibility of needing to accommodate an occasional vehicle on the bridge. For example, the security screens and shade canopies on the Kurilpa and Goodwill bridges were designed to allow access by an ambulance vehicle. A 3.5 m minimum height was provided.

For pedestrian only paths, the Bridge Code suggests a minimum vertical height of 2.4 m.

## **11 Clearances**

### **11.1 General**

Pedestrian and cycle bridges are invariably lighter than bridges carrying motorised vehicles, and so more vulnerable to vehicle impact. To mitigate the risk from collision, the specified vertical clearance over roadways is greater for an active transport bridge than it would be for a road bridge in the same location. The clearances nominated in the design references (refer Section 4.1) can be difficult to achieve without imposing significant costs. The appropriate values should always be discussed with the relevant agency at an early stage of the project.

Similarly, bridges over railways and waterways have specific clearance requirements specified by the appropriate authority (refer Section 4.5 of this guideline).

The horizontal separation to another existing, or planned facility (for example an adjacent bridge), will be dictated by constructability and future maintenance requirements.

### **11.2 Vertical**

The vertical clearance over roadways is generally more severe for a pedestrian or cycle bridge than it would be for a vehicular structure. The Bridge Code provides the following requirements:

- at least 200 mm greater than adjacent road traffic bridges, but not less than 5.4 m
- 5.5 m minimum where there are no adjacent bridges
- 6.0 m minimum on designated high clearance routes

- 6.5 m on designated very high clearance routes, and
- on a navigable waterway, at least 200 mm greater than the nearest road or rail bridges upstream or downstream.

In its Planning Scheme, Brisbane City Council stipulates that the minimum clearance over a Council road is 5.5 m (refer Section 4.6).

The Bridge Design Criteria, however, are more stringent than either of these references, nominating a preferred clearance of:

- 6.5 m for all 'footbridges' over declared main roads in Queensland, and
- 6.8 m over very high clearance routes.

For footbridges over local authority roads a clearance 1.0 m greater than any adjacent road bridge up to a maximum of 6.5 m is preferred. Sometimes, site constraints, such as insufficient space for complying access ramps, make this difficult to achieve at a reasonable cost. A compromise standard must then be negotiated. At Kurilpa Bridge (refer Figure 11.2(a)), a clearance of 5.5 m was adopted over the Riverside Expressway. In that case, however, a positive stop barrier had to be provided at one entry ramp to the expressway, to act as a filter for high vehicles, which added to the overall project cost.

**Figure 11.2(a) – Vertical clearance at Kurilpa Bridge**



When this form of filtering is required, there are obvious benefits in combining the barrier with another purpose, such as signage. An example of this is the combined stop barrier and signage provided on the approaches to the Hovenring pedestrian and cycle facility at Eindhoven in the Netherlands (see Figure 11.2(b)).



**Figure 11.2(b) – Combined stop barrier and signage at the Hovenring**

Where access ramps are required, the adoption of a high clearance, especially if combined with a deep girder bridge type, may result in longer and more expensive ramp structures. In such cases, consider the combination of all issues when arriving at the final solution for value-for-money to be maintained. In addition to acceptable clearance, these considerations will include:

- ramp grades and orientation
- pier locations
- structure and deck types
- barrier types, and
- the need for anti-throw screens.

### **11.3 Horizontal**

The department's Bridge Design Criteria suggests a minimum horizontal clearance between structures of 250 mm. More clearance may be required for reasonable access to adjacent structures for maintenance and replacement of bearings.

## **12 Access and mobility**

### **12.1 General**

Cycle and pedestrian bridges are frequently elevated above the route they grade separate. In these circumstances approach facilities must be provided. The ramps may need to be in structure if the area available for walkways is constrained. This can be the case in an urban environment.

These access structures can be extensive, and costly. Their configuration should be carefully considered and proportioned when siting the crossing point for a bridge. The grade of the walkway and ramps needs to be carefully selected. Unnecessarily flat grades will increase the length of ramps. Bridge superstructure options (refer Sections 14 and 15), in conjunction with clearance imperatives (refer Section 11) must also be considered at this time. Deeper superstructures will raise the height of a bridge, and may also increase the length of any associated ramps, with cost implications.

When the Ipswich Motorway was upgraded in 2011, several shared use crossings were built. This included the Goodna State School Bridge, previously shown in Figure 2.2(b). The approach works provided (refer Figure 12.1) are comparable in extent to the bridge they serve. While adverse site constraints are often unavoidable (refer Section 8), it is imperative, in the interests of value-for-money, that the extent of access works be minimised, consistent with the required mobility standards.

**Figure 12.1 – Goodna State School shared use bridge access facilities**

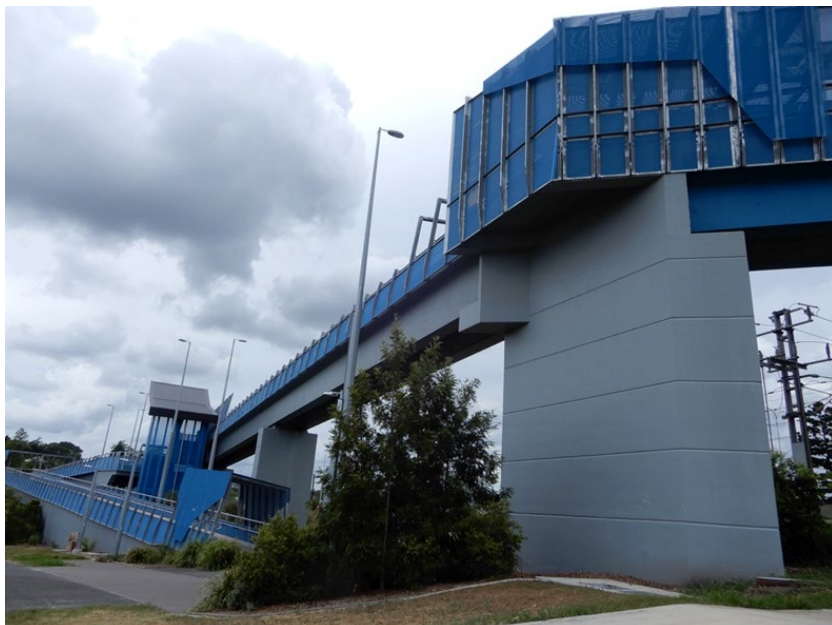

In summary, the length of any access facility required can be reduced by:

- selecting the most appropriate grade, as discussed below
- minimising the depth of bridge superstructure, which will lower the bridge height, and
- careful assessment of the required bridge clearance.

A considered approach to a combination of all these factors can result in shorter access walkways and ramps, with resultant cost savings.

For pedestrian only bridges and shared use structures, ensure that any approach access walkways and ramps (refer Section 12.2) provide access for those users with impaired mobility. The Bridge Code refers to both the *Federal Disability Discrimination Act*, and the access and mobility code for disabled users, AS 1428 (refer Section 4.9.3).

For bicycle only facilities, these access requirements do not apply. For cycle bridges the approach grade requirements are specified in the Bridge Code, which defers to Austroads Part 6A.

For shared use facilities, ramps can be augmented with separate flights of stairs to allow a more rapid climb, if preferred (refer Section 12.3). The Bridge Code refers to the *National Construction Code (NCC)* for compliance criteria.

School students often require special consideration (refer Section 4.8 of this guideline).

Bicycle wheeling ramps on stairs are also an optional treatment that should be considered for cyclists.

In circumstances where ramps cannot be accommodated, and only stairs are available, consideration can be given to installing lifts. This will always be a costly and ongoing expense.

## 12.2 Walkways, ramps and landings

In general, cyclists and pedestrians will prefer a gently sloping access. This will invariably lead to a longer facility, and greater costs.

Part 1 of the Bridge Code stipulates that access ramp gradients for cycle only access shall be in accordance with Part 6A, which references Figure 7.1 in that document.

When pedestrians can use the bridge, and people with a disability can therefore access the ramp, gradients must comply with AS 1428 (refer Section 4.9.3 in this guideline). This does not allow an approach gradient steeper than 1 in 14. AS 1428 prefers gradients flatter than 1 in 33, in which case landings; flat areas where wheelchair users can rest, are not required. The standard stipulates a minimum landing length of 1.2 m, but some designers consider this too short and adopt a more generous length of 1.5 m. Landings must have a grade flatter than 1 in 40. Cyclists do not appreciate such landings, but in shared use facilities they are generally unavoidable.

Space constraints around urban bridge sites normally mean that the ideal of a 3% access gradient is rarely achieved in practice. Steeper grades are usually provided. For gradients between 1 in 33 and 1 in 20 the access is defined as a walkway, with ramp intervals in accordance with Table 12.2(a). The interval for intermediate gradients is obtained by linear interpolation. Where a walkway is provided with a kerb and a complying handrail the landing intervals in Table 12.2(a) can be increased by 30%.

**Table 12.2(a) – General walkway configurations**

Gradient	Landing Interval
1 in 33	25 m
1 in 20	14 m

For gradients steeper than 1 in 20 the access is defined as a ramp. In determining the interval between landings for ramps there are two standards. The 'general' requirement (AS 1428.1), summarised in Table 12.2(b) below, is a minimum standard. The 'enhanced' requirement (AS 1428.2), shown in Table 12.2(c) below, is the preferred provision.

**Table 12.2(b) – General ramp configurations**

Gradient	Landing Interval
1 in 19	14 m
1 in 14	9 m

**Table 12.2(c) – Enhanced ramp configurations**

Gradient	Landing Interval
1 in 19	14 m
1 in 14	6 m

In both ramp cases the interval for intermediate gradients is obtained by linear interpolation.

For example:

For the Toowong Crossing access ramp (refer Figures 12.2 and 13.1), the space available allowed the adoption of a 1 in 14 grade with rests at 6 m intervals (that is, at 7.5 m centres) – an ‘enhanced’ ramp condition. At the Redcliffe High School (refer Section 12.3), however, space constraints and clearance imperatives at the road crossing required a steeper ramp. A landing interval of 9 m (that is, at 10.5 m centres) was adopted – a ‘general’ ramp configuration. For the Goodwill and Kurilpa Bridges a gradient of 1 in 20 was used with a landing interval of 18.2 m (19.7 m centre to centre) – a walkway situation (Table 12.2(a)) with the 30% criteria invoked (i.e.  $[14 \text{ m} \times 1.3 = 18.2 \text{ m}] + 1.5 \text{ m} = 19.7 \text{ m}$ ).

**Figure 12.2 – Approach ramp on Toowong Crossing**



These examples indicate that the bridge designer has some scope to limit ramp lengths to suit particular circumstances. Flatter gradients, while desirable, will invariably involve longer and consequently more expensive access ramps.

### 12.3 Stairs

Stairs as an additional access option may suit some patrons, but will always add to the cost of a bridge. The decision to include stairs needs careful consideration.

The Bridge Code generally defers to the *National Construction Code (NCC)* for compliance criteria associated with stairways.

For public stairways, the Building Code (NCC) requires that going (G), riser (R) and the quantity  $2R+G$  comply with Table 12.3 below, which is a short summary of Table D2.13 in the Building Code. In addition, the Bridge Code suggests that stairs not be steeper than 1 in 1.6.

**Table 12.3 – Stairway configurations**

Riser (R)		Going (G)		Quantity (2R + G)	
Max (mm)	Min (mm)	Max (mm)	Min (mm)	Max (mm)	Min (mm)
190	115	355	250	700	550



The access standard (refer Section 4.9 of this guideline) stipulates that stairways should not have open risers. Where this is difficult to achieve, the Building Code (NCC) requires that risers with an opening should not allow a 175 mm diameter sphere to pass between them.

At the Goodna State School Bridge access shown in Figure 12.1, a stairway has been provided for patrons wishing to avoid the long ramps (refer Figure 12.3(a)).

**Figure 12.3(a) – Access stairs at Goodna State School bridge**



The design standards for school facilities (refer Section 4.8 of this guideline) require that, where students are involved, the going should not be less than 300 mm and risers not more than 175 mm (preferably 150 mm for primary school students). For students, each set of steps within a stairway should provide a maximum of eight risers and a minimum of two.

A set of stairs provided for students at the Redcliffe State High School overpass is shown in Figure 12.3(b).

**Figure 12.3(b) – Stairway access for students at Redcliffe State High School**



Where stairs only are provided, and cyclists can access the bridge, Part 6A (refer Section 4.3 in this guideline) suggests the stairway should incorporate a wheeling ramp for the ease of cyclists.

While the situation in Figure 12.3(c) is not ideal for cyclist amenity, it does demonstrate that stair only access to a cycling facility can, with considered use of wheeling ramps, be provided in the absence of a ramp.

**Figure 12.3(c) – Stairs only access to Sydney Harbour Bridge cycleway**



## 13 Materials

### 13.1 General

The primary elements of pedestrian and cycle bridges can be built from a variety of materials, including:

- concrete
- steel
- aluminium
- timber, and
- fibre reinforced polymer.

Bridges can be composed of a single material, but more often exist as combinations of materials. For example, a bridge may consist of structural steel truss with a timber deck, founded on steel reinforced concrete abutments.

All of these materials have a finite life. The durability of bridge materials is determined by two primary influences.

- **Deterioration** - how well the materials manage the ravages of time and circumstance, and
- **Misuse** - irresponsible user behaviour, either intentional (vandalism) or accidental.

The materials considered for a bridge should be selected on the basis of their applicability for the structure type options available, and the relative aggressiveness of environmental conditions at the site. They should then be assessed on their durability, the means available for maintenance, and the ease with which that can be achieved.

Good construction practice, with diligent adherence to specifications, is essential.

Refer to the Toowong Crossing in Figure 7.2(a). Steel was chosen because of the need to curve numerous spans. Over the Western Freeway, the steel was galvanised as future maintenance of a painted structure will be difficult, given the heavy traffic. The ramp steelwork was painted, as galvanising would have required complicated detailing, and the ramps can be accessed easily for future maintenance (refer Figure 13.1). The piers and abutments were either reinforced concrete, for the main spans, or structural steel for the ramps.

**Figure 13.1 – Toowong Crossing shared use bridge**



### **13.2 Concrete**

Concrete is invariably used in combination with steel (see Section 13.3 below) in two principal forms, reinforced concrete and prestressed concrete. Often a bridge will comprise reinforced concrete foundations, prestressed concrete girders, and a reinforced concrete deck. The design of structural concrete in its various forms (plain, reinforced, prestressed) is covered in Part 5 of the Bridge Code.

Often, bridge designers will bring their experience of concrete road bridges to the design of various elements of a pedestrian or cycle bridge. The imposed live loads require a reassessment of member sizes to ensure value-for-money.

Concrete can be an extremely durable material, provided that the selection of concrete strength, mix design, and cover to reinforcement are compatible with the site conditions. These are determined by reference to the appropriate exposure classification in the Bridge Code.



The Bridge Design Criteria makes particular recommendations about both strength and cover to reinforcement. This includes the requirement that bridges with a 100 year design life be designed for a B2 exposure classification. Consequently, the default minimum strength specified for reinforced concrete has become 40 MPa, rather than the previously adopted 32 MPa. Of course, stronger concrete will generally be more expensive. To ensure value-for-money, care should be taken to ensure that the proportioning of members takes advantage of the concrete's additional strength.

The relevant Transport and Main Roads Technical Specification is MRTS70 *Concrete*.

Concrete as a pedestrian or cycle bridge material has a typical span range up to about 40 m, although recent innovations in wide flange I beams offer the potential to increase this range by some 20%. This limits its application where longer spans are required, especially where clearance is also a constraining factor.

### **13.3 Steel**

In pedestrian bridges, structural steel can be used alone in girders, piers, trusses, parapets, railings and fitments. It is also used as a reinforcing and prestressing agent for concrete (see Section 13.2).

Steel girders can also be used with reinforced concrete in a composite section that enhances the properties of the steel girder acting alone. When using a reinforced concrete deck on steel girders, assess this construction so the depths of both steel girder and concrete deck are minimised. This is important, in the interest of value-for-money.

The design of steel, both alone or acting compositely with concrete, is covered in Part 6 of the Bridge Code.

An advantage of steel is that it can generally be used over a wide range of span lengths and clearance constraints. It suits fabrication into girders, trusses, arches, and cable stay structures.

The relevant Transport and Main Roads Technical Specification is MRTS78 *Fabrication of Structural Steelwork*.

Steel can be a durable material, but needs to be adequately protected against corrosion. Protection in accordance with AS/NZS 2312 (minimum Corrosivity Category is C3; C5M in marine environments) should be provided.

Durability is also best served by good detailing. The joint shown in Figure 13.3(a) would be improved if it avoided entrapment of water.

**Figure 13.3(a) – Truss joint detail**



Galvanising and painting are the two primary anti-corrosion methods used. Powder coating is also used, but generally only for secondary elements such as balustrades and rails. The use of weathering steel may be justified in certain circumstances.

The preferred method, in terms of longevity, is hot dip galvanising. Its sole use in prominent locations, where visual amenity is important, can be inappropriate. Painting as the primary corrosion protection may be considered when hot dip galvanising is not practical or cost effective. Painting is often preferred on aesthetic grounds.

Historically, galvanising has been more expensive than painting, although this can be influenced in certain markets by:

- availability of competing suppliers, and
- prevailing supply cost of zinc.

An assessment of the cost differential should always be part of any options analysis, as the differences in cost fluctuate.

Assessing the practicalities of hot dip galvanising may include the:

- length of the available galvanising baths, and
- added complexity of fabrication needed to meet the demands of the process.

Most baths are only 10 to 12 m long. This limits the length of any structural member before a joint is required, which adds to the cost of fabrication. Joints can also be unsightly. They can detract from the smooth lines of a bridge. In addition, any closed members require venting. Providing vent holes creates complications, both in design and fabrication.

For several recent bridges using long steel trusses, spans were fabricated in numerous sections so they could be galvanised. Subsequently, all sections then had to be joined prior to erection, either in the fabricator's workshop or on site. Two examples illustrate the difficulties in balancing the pros and cons of various combinations of joint type and erection method.

For the Anderson Road Bridge in Cairns (refer Figure 13.3(b)), all joints were formed by:

- welding plates perpendicular to the hollow section ends, then
- bolting together the contact faces, on site, after galvanising.

The joints are very prominent. The structure is also wider than necessary, as the concrete deck must be clear of the contact plates on the bottom chords. Consequently, steel bridging plates are required to fill the gap between the deck and the bottom chords. So while bolted contact plates provide a relatively cheap joint, they cost more for a wider floor support structure and kerb plates.

**Figure 13.3(b) – Anderson Road bridge, Cairns**



These additional costs are avoided by the arrangement shown in Figure 13.3(c). Discrete, bespoke joints were used, although the connections were relatively expensive.

**Figure 13.3(c) – Juliette Street bridge, Brisbane**



There is another difference between the two schemes. At Anderson Road there was enough room to join the galvanised sections on site. For the more constrained Juliette Street bridge site, the trusses were all joined in the fabricator's shop and delivered to site complete.

These issues of anti-corrosion treatments, fabrication, jointing, transportation and erection all need to be considered when determining the most cost effective option for a steel bridge.

If painting is adopted as the protective measure, the paint specification should be sufficient to last at least 15 – 30 years before there is any need for a repaint, depending upon:

- the type of structure
- its location, and
- the ease with which repainting can be carried out.

There is some evidence that painted closed sections are prone to internal corrosion, which can be difficult to detect. Where possible, open sections should be used for painted structures.

Stainless steel is frequently used for fitments where high durability is required, for example hold down bolts (refer Figure 13.3(d)). The relative cost of bolts in a bridge project is generally quite low. They will usually represent good value-for-money, especially considering their importance.

**Figure 13.3(d) – Stainless steel hold down bolts**



Stainless steel is also often used for connecting aluminium structures.

Stainless steel is occasionally adopted for handrails, although it will invariably be more expensive and its value-for-money should always be assessed (refer Section 20.1).

Consideration must be given to isolating stainless steel from dissimilar metals to avoid galvanic corrosion.

Stainless steel reinforcement may be justified in a marine or other aggressive environment.

### **13.4 Aluminium**

Aluminium can be used in cycle and pedestrian bridges for all the primary superstructure elements. The relative lightness and corrosion resistance of this material, compared to steel and concrete, offers potential benefits. There are numerous examples of aluminium shared use bridges in Queensland, which incorporate spans in the range 12 – 52 m.

Aluminium bridges are not recognised by the Bridge Code, although the material has a potential applicability for pedestrian and cycle bridges. In the absence of a Part in AS(/NZS) 5100:2017, designers are obliged to use the following design standards:

- AS/NZS 1664.1:1997 *Aluminium Structures, Part 1: Limit State Design*
- AS/NZS 1664.2:1997 *Aluminium Structures, Part 2: Allowable Stress Design*
- AS/NZS 1665:2004 *Welding of Aluminium Structures*
- AS/NZS 1886:1997 *Aluminium and aluminium alloys – Extruded rod, bar, solid and hollow shapes*
- AS/NZS 1734:1997 *Aluminium and aluminium alloys – Flat sheet, coiled sheet and plate*
- AS 1231:2000 *Aluminium and aluminium alloys – Anodic oxidation coatings.*



Only certain grades of aluminium will be suitable for bridges in terms of strength and resistance to corrosion. Aluminium should be at least grade 6061 – T6 and preferably anodised.

Occasionally, aluminium is used for screening steel bridge structures (refer Figure 13.3(c)). Care should be taken to avoid galvanic corrosion.

### **13.5 Timber**

Timber has been used for all the principal bridge elements. It is not now commonly used in Queensland for public infrastructure active transport bridges, owing to perceived sustainability and durability issues.

Properly detailed and specified, durable timber structures can be appropriate in certain situations where dry conditions are predominant.

The Bridge Code includes Part 9: *Timber*. Although this is an acknowledgement that timber is a legitimate bridge construction material, it does limit its applicability, for new bridges, to the following:

- Seasoned, kiln-dried, sawn timber
- Glued-laminated timber (glulam), and
- Structural laminated veneer lumber.

Unseasoned or round un-sawn timber is not endorsed in this Part of the Bridge Code. Their use in rehabilitating or strengthening existing bridges would be possible under Part 8 of the Code.

Part 9 of the Bridge Code does not apply to bridge members that are in contact with either the ground or water. This implies that substructures are expected to be another material. The Cultural Centre Boardwalk at Southbank in Brisbane (constructed circa 1993) has round timber piles in the river (refer Figure 13.5). The Boardwalk would probably not comply with the current Bridge Code.

**Figure 13.5 – Cultural Centre Boardwalk, Brisbane**



Timber bridges are susceptible to fire damage (refer Section 13.8 in this guideline).



### **13.6 Fibre Reinforced Polymers (FRP)**

FRP can be used for almost all the superstructure elements of pedestrian and cycle bridges. Although FRP is an established material, its application for pedestrian and cycle bridges in Queensland is a recent technology.

FRP bridges are not recognised by the Bridge Code. The material has applicability for pedestrian and cycle bridges, and there are numerous examples in Queensland.

Design of FRP elements is considered comprehensively in the Bridge Design Criteria, and the department maintains Transport and Main Roads Specifications for the fabrication and use of FRP in bridges (refer Table 4.1).

FRP potentially offers benefits in terms of lightweight construction and corrosion resistance. Its long-term performance as a bridge material is not currently available. Long-term issues, such as lamination, are potential considerations.

FRP is susceptible to fire (refer Section 13.8).

### **13.7 Recycled plastics**

Recycled plastic products are available for decks (refer Section 15.7). They offer durability and sustainability advantages over timber decks, although they are susceptible to damage by fire (refer Section 13.8).

### **13.8 Misuse and vandalism**

All materials are susceptible to accidental misuse or determined vandalism, but some more so than others, particularly timber, aluminium, FRP, and recycled plastic.

The risk of vandalism can be reduced through adequate passive surveillance. Materials that are at risk from vandalism damage should not be used in isolated locations that lack such surveillance.

Figure 13.8(a) shows the result of a deliberately lit fire on a steel truss bridge. The deck originally comprised recycled plastic planks supported on hollow section FRP joists. These were both comprehensively destroyed. The steel truss survived and the deck has been refurbished.

**Figure 13.8(a) – Fire damage to recycled plastic deck**



Figure 13.8(b) shows the result of vandalism on a lightweight aluminium balustrade. The balustrade on two bridges at the site was extensively damaged, and required replacement.

This is a potential instance of poor value-for-money, where high ongoing maintenance and / or replacement expenses can overshadow low initial costs.

**Figure 13.8(b) – Damage to lightweight aluminium balustrade**



Designers should consider the risk of both accidental damage and vandalism. They should produce suitably robust defences and be particular with site selection.

## **14 Bridge types**

### **14.1 General**

A wide variety of pedestrian and cyclist bridge types are possible because the combination of structural type and materials lead to many configurations. The principal types are:

- single girder (refer Section 14.3)
- multi-girder (refer Section 14.4)
- slab (refer Section 14.5)
- truss (refer Section 14.6)
- arch (refer Section 14.7), and
- cable supported (refer Section 14.8).

### **14.2 Span lengths**

The Bridge Design Criteria suggests that the length of spans '*shall be maximised where practical, within the context of the necessary bridge length*'.

This can be an aesthetic consideration. A long clear span will generally be more visually appealing than several short spans cluttered with piers. Also a long span may be selected to avoid a pier within the clear zone. To sustain collision loads, piers need to be overly robust relative to the structural demands of standard active user loads.

Nevertheless, the final span selection should be the result of a rigorous options analysis, considering the following:

- Widely uneven span lengths should be avoided, if possible. They can look unappealing, especially if the depth of any girders is reduced relative to their span lengths. If a common girder depth is maintained for aesthetic reasons, this will render the shorter girders inefficient and add cost (refer Section 5).
- Long spans, using girder bridge types, will generally involve deeper girders than shorter spans. If clearance is an issue, this could raise the height of the bridge, relative to its surroundings. Ramifications could include the increased length of any access ramps, and eventual cost implications. If room for the ramps is constrained, shorter spans may be preferable.

While the selection of bridge types and girder lengths is a matter for designers, the following advice may be used as a guide.

- **Single girder** – This type is capable of PSC spans up to and potentially in excess of 40 m, while continuous steel spans over 60 m are possible.
- **Multi – girder** – Span lengths are generally as for single girders. PSC I and T-girders could approach 50 m spans, although when using the department’s deck units, spans are limited to approximately 25 m. FRP and timber girders can be used, although the current limit appears to be approximately 12 m.
- **Slab** – Insitu and proprietary precast slabs are in the range up to 15 m, although spans approaching 20 m are possible with careful detailing. Orthotropic slabs, up to 25 m, can be adopted using the department’s deck units.
- **Truss** - This is a very adaptable type with current steel and aluminium examples in the 10 – 60 m range. Aluminium trusses are considerably deeper and more heavily braced than the steel variety. Trusses in excess of 45 m can be difficult to transport, and may require an area near the bridge site where sections can be connected. FRP trusses up to 25 m have been erected. Long timber trusses are possible, but rarely promoted, although Part 9 of the Bridge Code offers possibilities.
- **Arch** – Generally used for longer spans. Like the truss, this is an adaptable bridge type and could be used for shorter spans, especially where a shallow deck structure is required.
- **Cable supported** – Another bridge type most suited to long spans. Like the arch and the truss, this type is occasionally used for shorter spans. This provides a dramatic effect, but may be also used where a shallow deck structure will assist with clearances.

### **14.3 Single girder bridges**

#### **14.3.1 Introduction**

This type is normally characterised by a T section, which can be formed from a variety of materials, principally:

- reinforced and / or prestressed concrete
- steel, or
- a composite combination of steel and concrete.

The application of the single girder type is controlled by the possible width of the flange, which normally limits the usable width to 3 m. The configuration of bearings is also an important consideration, to ensure stability, and two bearings at each end are generally required.

For PSC, spans approaching 50 m are possible with this type of bridge. At Falcon Street in Sydney, a 60 m continuous span was achieved in steel (refer Section 14.3.3). As span increases so, in general, does the girder depth. This has implications for bridges with both a clearance imperative and a need to provide access ramps (refer Section 12). As a general rule, the longer the span, the deeper the girder, the higher the bridge, and the longer the ramp required.

### 14.3.2 Single reinforced and / or prestressed concrete girder

The Moggill Road cycle bridge (refer Figure 14.3.2(a)) is an example of a PSC T-girder bridge, with a composite RC decks and precast concrete kerbs (refer Figure 14.3.2(b)).

**Figure 14.3.2(a) – Moggill Road cycle bridge**



**Figure 14.3.2(b) – Girder at Moggill Road bridge**

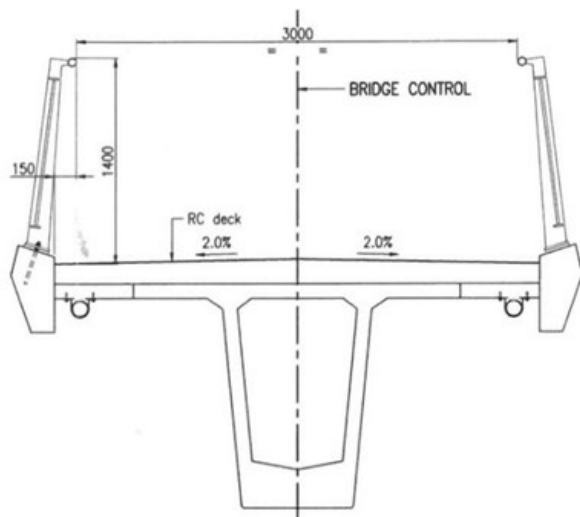

### 14.3.3 Single steel girder

An example of a steel girder bridge is the Falcon Steel pedestrian bridge in North Sydney (refer Figure 14.3.3(a)). This is a closed trough girder (refer Figure 14.3.3(b)). The top flange, with a skid resistant coating (refer Section 15.9), forms the deck.

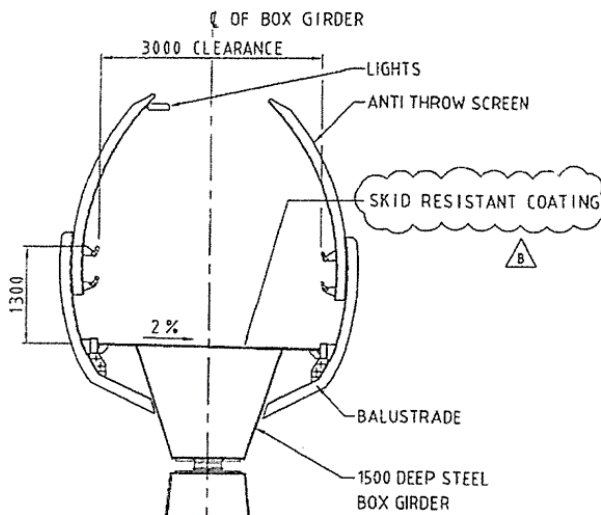

**Figure 14.3.3(a) – Falcon Street bridge****Figure 14.3.3(b) – Steel girder at Falcon Street bridge**

Advantages of steel girders are the ability to create relatively long spans and to incorporate curves within their length.

A disadvantage, especially for closed sections such as this, is the difficulty of providing a sufficient anti-corrosion surface to the inside of the box. Also, future inspection inside such closed box sections can be difficult unless inspection points are provided.

Another example of this bridge type is the Stanley Street on-ramp, at Woolloongabba. This incorporates a composite RC deck formed by an in-situ topping on a precast panel shown in Figures 14.3.3(c) and 14.3.3(d).

**Figure 14.3.3(c) – Stanley Street on-ramp bridge**

Figure 14.3.3(c) demonstrates steel's ability to form relatively tight curves, a clear advantage of the material, with potential cost savings in certain circumstances.

The steel trough section of the Stanley Street on-ramp bridge is open at the top (refer Figure 14.3.3(d)), so a high quality paint system could be applied initially. This is an advantage over closed box girders, although the issue of future inspection still requires resolution. There is also the general need to consider safety in design issues for maintenance workers inside any box girder.

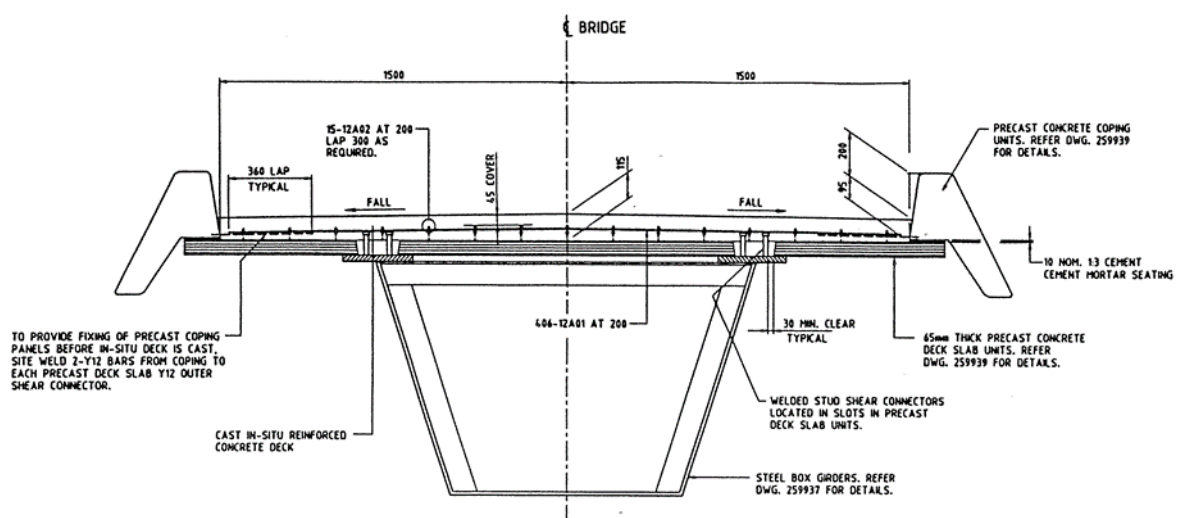
**Figure 14.3.3(d) – Stanley Street on-ramp bridge type cross section**

## 14.4 Multi-girder bridges

### 14.4.1 Introduction

This is a simple and traditional style of bridge where two or more rows of girders support a slab or plate deck, spanning between the girders. The possible width of this type is not limited, as the width can be extended by adding another girder. This type is not constrained by girder material, where concrete, steel, timber, and FRP girders have all been used.

Numerous girder section types are possible, including the following:

- Rectangular sections, such as:
  - standard Transport and Main Roads prestressed concrete deck units (refer Figure 14.4.1)
  - steel hollow sections
  - timber, and
  - FRP.
- T - sections, like the prestressed concrete Super-T
- U (trough) - sections, either in prestressed concrete or fabricated steel
- I – sections, either in prestressed concrete or steel (rolled or fabricated)
- C – sections, generally rolled or fabricated steel.

**Figure 14.4.1 – Girder arrangement at Schulz Canal shared use bridge**



Various types of deck slabs and plates are also available, including:

- precast concrete
- in-situ concrete
- timber
- FRP
- aluminium

- recycled plastic, and
- ECC.

These deck types are more fully explored in Section 15.

Concrete deck slabs are most efficiently and cost effectively used when they act compositely with the supporting girders. There is a tendency to make decisions about concrete deck thickness, often based on the precedents set by road bridge designers. Thickness of concrete decks should be appropriate for the use. A reduction of 40 mm of concrete is 1 kPa of dead load saved, and the cost of the concrete itself is minimised.

#### 14.4.2 Concrete girders

A common example of this type, such as the Witton Creek Cycle Bridge (refer Figure 14.4.2(a)), uses standard Transport and Main Roads PSC deck units with a composite RC deck (refer Figure 14.4.2(b)). The Schulz Canal Bridge, shown in Figure 14.4.1, demonstrates the versatility of this style, where three girders have been used to provide a wider deck.

**Figure 14.4.2(a) – Witton Creek bridge on the Centenary Highway cycleway at Indooroopilly**



**Figure 14.4.2(b) – Type cross section of the Witton Creek bridge**

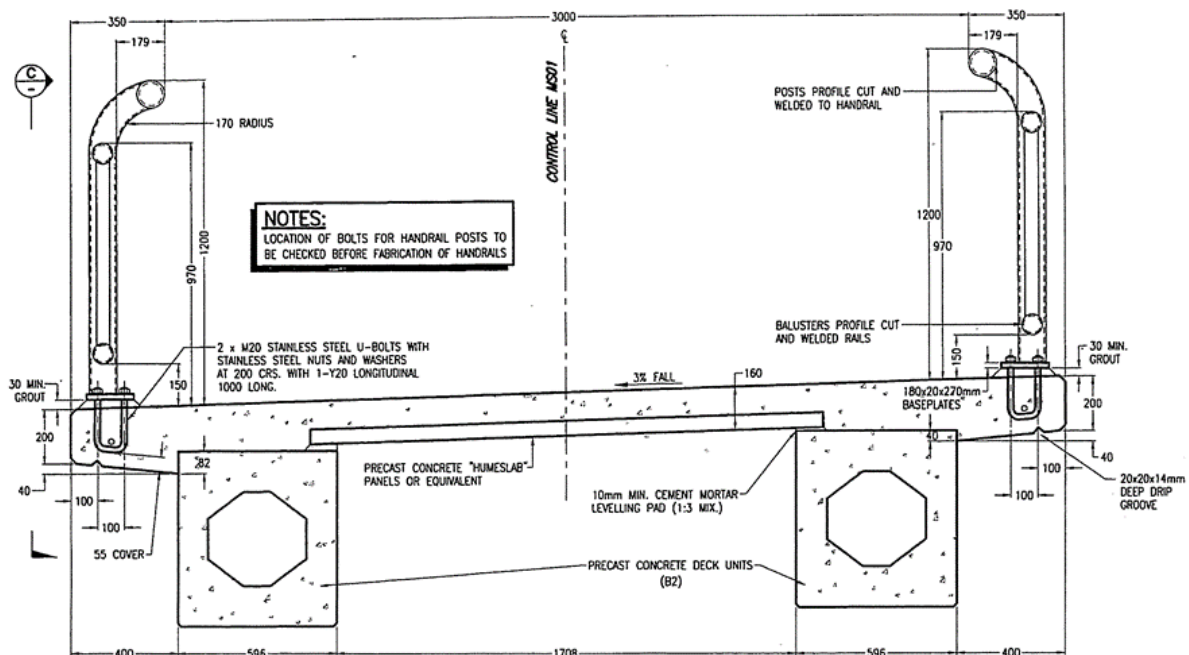



This type provides a very durable bridge for simple spans up to 25 m. There can be a tendency to mimic details used for road bridges. A more efficient structure should be possible for active users, given the lighter live loads involved with pedestrian and cycle bridges.

If longer spans are required, single T-girders can be used in unison, as shown in Figure 14.4.2(c). Spans up to 40 m are possible with this arrangement, while a recent innovation in wide flange I girders may extend this range closer to 50 m.

**Figure 14.4.2(c) – Type cross section of the Lewisham Street bridge**

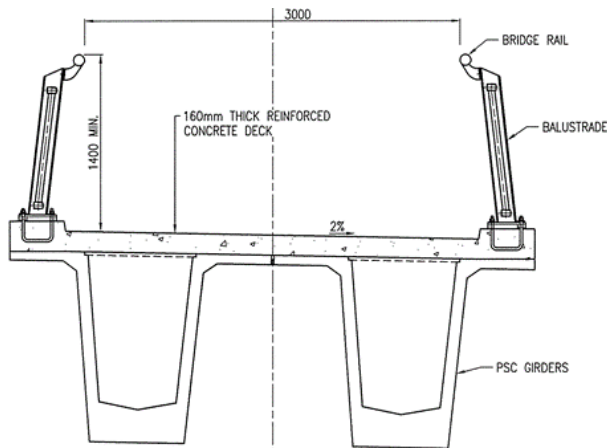

These bridges offer all the durability advantages of concrete, although they do become deeper as the span increases. For a given clearance imperative they raise the height of the deck surface and increase the length of any access ramps. This potentially increases costs (refer Section 12).

To overcome a height constraint, the slab can be supported on corbels near the underside of the girders, rather than on top of them. An example is at Barfoot Street on the Deagon Deviation (refer Figure 14.4.2(d)). Similar bridges at Anzac Square in Brisbane, and on the Kurilpa Bridge Tank Street approach use the same style. This is useful when clearance under a bridge is an issue (refer Section 11.2).

**Figure 14.4.2(d) – Barfoot Street footbridge type cross section**

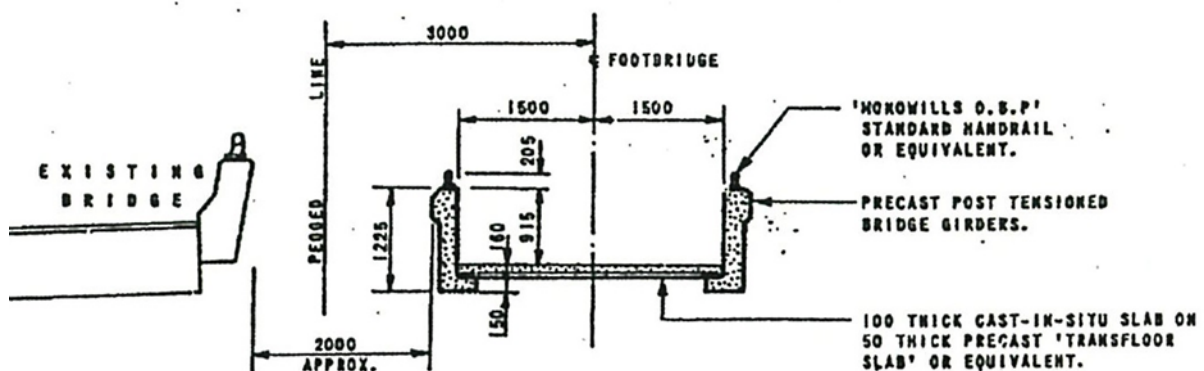

A potential disadvantage of this type lies in the obscured nature of the corbel seat, and the difficulty of inspecting it for potential defects in the long term. These concerns could be overcome with careful detailing.

### 14.4.3 Steel girders

Another variation of this type uses steel girders, such as the Fearnley Street bridge in Cairns (refer Figure 14.4.3(a)), which has a composite RC deck. The typical cross section for this bridge is shown on Figure 14.4.3(b).

**Figure 14.4.3(a) – The Fearnley Street bridge in Cairns**



**Figure 14.4.3(b) – Type cross section of the Fearnley Street bridge**

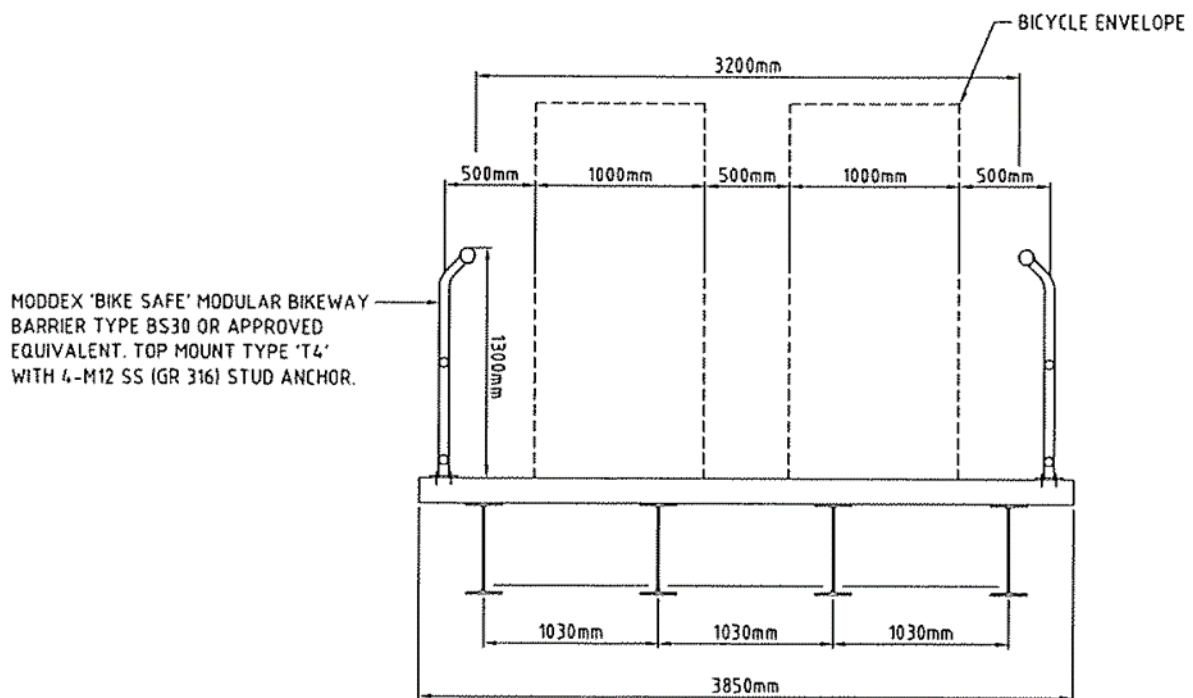

An advantage of this type is that it can use standard rolled steel sections. These may be more readily available in some areas, and can be lighter to install than precast PSC sections.

A disadvantage is the need to consider an anti-corrosion treatment method. If galvanising is chosen, jointing of the girder sections may increase costs. The Fearnley Street bridge designers avoided this by painting the girders instead.

#### 14.4.4 FRP girders

Fibre reinforced polymer girder bridges have been installed using a combination of glued FRP hollow section pultrusions (refer Section 13.6) and an ECC plate deck (refer Section 15.8), as shown in Figure 14.4.4. This is an example on the Bicentennial bikeway at Toowong.

**Figure 14.4.4 – FRP girder bridge on the Coronation Drive cycleway**

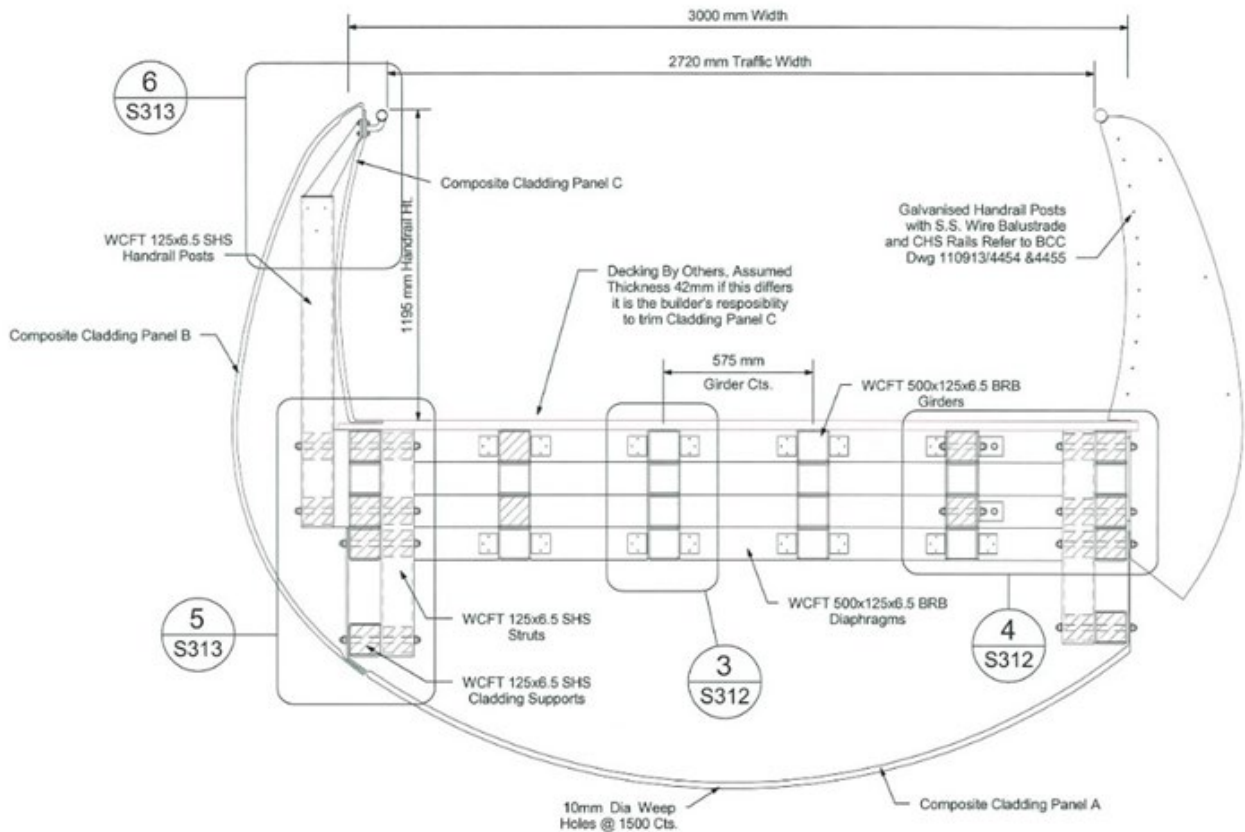

This type can be useful for short spans (up to 12 m), especially when access is difficult. They are relatively light to transport, with potential cost advantages.

#### 14.5 Concrete slabs

##### 14.5.1 Insitu concrete slabs

Slab bridges can be cast in-situ, as for the bridge at Roslyn Street in Rushcutters Bay in Sydney (refer Figure 14.5.1). The construction imperative for formwork and its temporary supports can limit its applicability.

**Figure 14.5.1 – Pedestrian bridge at Rushcutters Bay, Sydney**



#### **14.5.2 Precast concrete slabs**

Slab bridges can also be precast, as in the bridge over Obi Obi Creek at Maleny, shown in Figure 14.5.2. This comprises a hollow-core slab, although other proprietary precast sections are available.

**Figure 14.5.2 – Maleny Trail shared use bridge**



Thin slab bridges, either cast in-situ or precast, offer an advantage where clearance is an issue. They are, however, sensitive to dynamic behaviour and this requires careful attention.

Precast concrete allows modularisation, which is illustrated in Section 25.



### 14.5.3 Orthotropic concrete slabs

#### 14.5.3.1 General

Orthotropic concrete slabs can be formed from a series of standard Transport and Main Roads deck units, linked together by either transverse stressing bars, or a composite concrete deck slab. The principal advantage of this type is that it offers a reduction in depth compared to multi-girder bridges of comparable spans, without compromising the durability advantages of concrete.

#### 14.5.3.2 With transverse stressing

A recent example of this type is at Honeyeater Drive on the Gold Coast (refer Figure 14.5.3.2). This bridge has an AC surface, which avoids the need to install an in-situ concrete deck. This may offer initial cost advantages. The potential need to eventually replace the AC, and to ensure future waterproofing, may increase its whole-of-life cost. Corrosion of the stressing bars needs consideration in coastal environments.

**Figure 14.5.3.2 – Honeyeater Drive shared use bridge cross section**

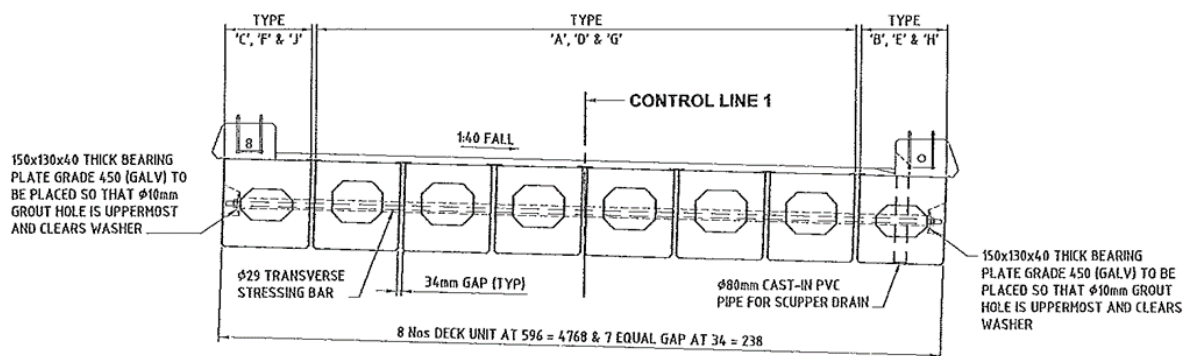

#### 14.5.3.3 With reinforced concrete deck

This type of orthotropic slab uses a composite reinforced concrete deck to connect the deck units. Numerous examples of the type exist on the V1. Vertical clearance has been an issue over both roadways and waterways, as in the case of the Bulimba Creek bridge on the V1 (refer Figure 14.5.3.3). The relatively thin concrete deck combines compositely with the department's deck units, which have been prestressed to suit the pedestrian live loads nominated in the Bridge Code.

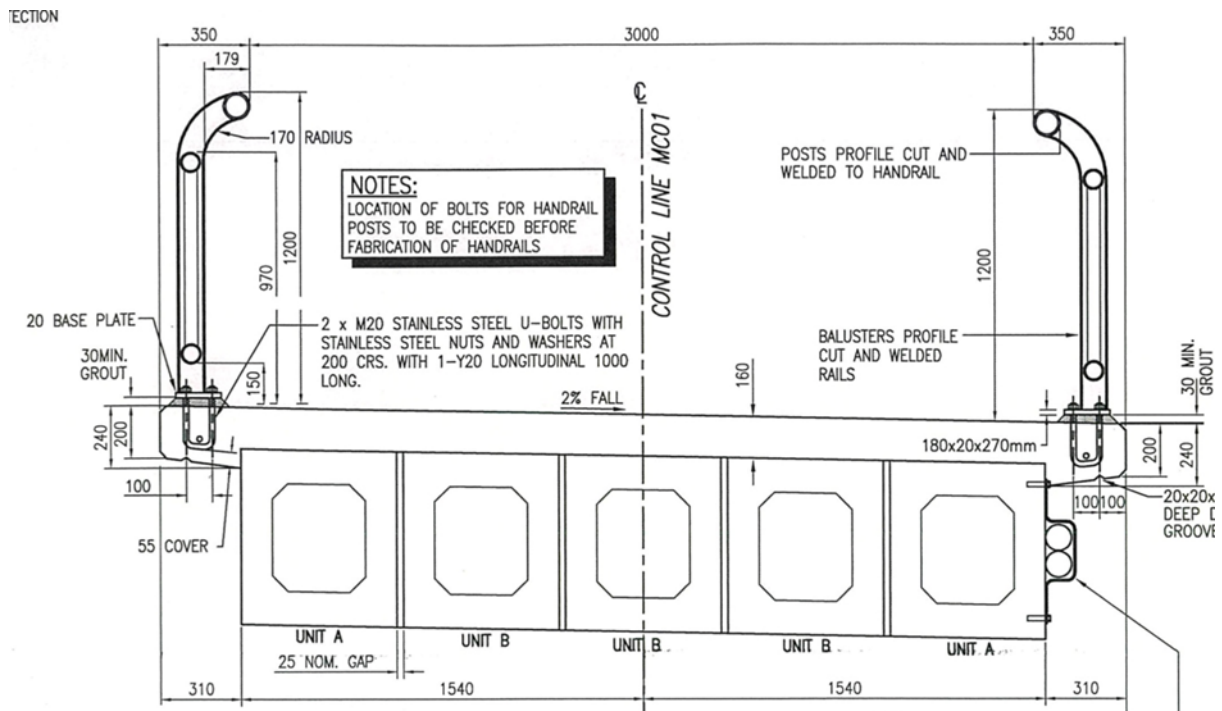
**Figure 14.5.3.3 – V1 Bulimba Creek cycle bridge cross section**

This type is inherently more durable than the transversely prestressed option. It provides greater flexibility in terms of cross-fall and vertical alignment.

## 14.6 Truss bridges

### 14.6.1 General

The through truss is often used in pedestrian bridges because it can minimise the superstructure depth / span ratio over relatively long distances. The truss in Figure 14.6.1 is the crossing of Moody Creek by the Southern Cycleway in Cairns. It has an effective depth of only 405 mm from the riding surface to the underside of the truss bottom chords, as most of the truss structure is above the deck. This results in an effective depth to span ratio of almost 1:100. A ratio of 1:25 would be more likely for a standard precast girder bridge, or 1:30 for a slab bridge.

**Figure 14.6.1 – Bridge at Moody Creek, Cairns**

This is particularly useful when crossing transport corridors, especially when access ramps are required. It allows the height of a structure's deck and the length of ramps to be minimised, with potential cost savings. For the Moody Creek bridge, it allowed the bridge to maintain an acceptable clearance above H.A.T without significant approach works.

Trusses have the ability to cross relatively long distances. The Moody Creek bridge has a span of 40 m. Similar spans have been constructed in other parts of Queensland. The truss bridge shown in Figure 1.1, on Veloway V1 in Brisbane, has a span of 38 m.

When designing trusses, it is important to consider both the overall form and connection details. Aesthetics should be considered.

Trusses can be fabricated from a variety of materials, including:

- a) steel
- b) aluminium
- c) timber, and
- d) FRP.

Various types of deck (refer Section 15) may be installed on trusses, including:

- e) precast concrete
- f) in-situ concrete
- g) a combination of (e) and (f)
- h) timber
- i) FRP
- j) aluminium
- k) ECC, and
- l) recycled plastic.

The steel truss over Moody Creek has a deck comprising ECC panels on FRP stringers.

#### **14.6.2 Steel trusses**

Over the last decade a series of five steel trusses have been constructed along the V1 Bikeway. The crossing of Ekibin Creek (refer Figure 14.6.2(a)) is a two span bridge with lengths of 20 and 35 m.

**Figure 14.6.2(a) – Ekibin Creek cycle bridge**





All these bridges are trusses because of some site impediment, being one or more of the following:

- clearance constraint
- imposed minimum span imperative, and / or
- an access requirement.

Figure 14.6.2(b) shows the cycle bridge at Juliette Street. The planning example is also discussed in Sections 6 and 13.3 (refer Figure 13.3(c)). Spans of 40, 60, and 35 m were required and achieved by fabricating three 45 m trusses. These were then configured to allow cantilever construction for the long central span.

**Figure 14.6.2(b) – Juliette Street cycle bridge**



After selecting the span lengths and bridge types, the principal design consideration for all these bridges was provision of an anti-corrosion treatment. For each one, galvanising was the principal method chosen. This was mainly because of the inherent difficulties associated with resurfacing the steel in the future.

### **14.6.3 Aluminium trusses**

A primary example of an aluminium truss is the one at Jindalee Park in Brisbane (refer Figure 14.6.3(a)), which has a span of 52 m. All the elements of the truss are aluminium including the balustrade, rail, and the deck, which has a non-slip surface applied (refer Section 15.9).

**Figure 14.6.3(a) – Jindalee Park bridge**

While aluminium has inherent anti-corrosion characteristics, and good strength properties, it has a low modulus of elasticity compared to steel. The truss is considerably larger than a steel alternative. Nevertheless, aluminium is considerably lighter than steel and it may have been chosen for this reason, as the site is particularly constrained for construction access. From the available cost data, there is no evidence that this particular bridge type offers any initial cost advantages for long spans. Nor would this particular bridge have any advantage where clearance is an issue, as it is heavily braced beneath the deck slab, and so offers fewer of the benefits noted in Section 14.6.1.

Alternatively, the project cost of the Eudlo Creek bridge at Maroochydore (refer Figure 14.6.3(b)), completed in 2017, suggests that short span aluminium truss bridges, provided by specialist suppliers under a Design and Construct (D&C) contract, may well offer a cost advantage in certain circumstances (refer also Section 15.2.1). This is another example of a flexible delivery mechanism providing value-for-money, as introduced in Section 7.3.

**Figure 14.6.3(b) – Eudlo Creek shared use bridge (during construction)**

#### **14.6.4 FRP trusses**

Numerous FRP truss bridges, like the Ballin Park bridge in Toowoomba (refer Figure 14.6.4), have been constructed around Queensland with spans up to 28 m.

FRP has strength properties similar to steel. It offers potential as a non-corrosive material, although its long term durability has not yet been demonstrated.

Like aluminium, the modulus of elasticity of FRP is lower than steel. Bridges from this material need to be checked for adherence to serviceability criteria (refer Section 19).

**Figure 14.6.4 – Ballin Park shared use FRP truss bridge, Toowoomba**



#### **14.7 Arch bridges**

Arch bridges are a useful way to execute long spans. They have been used in a variety of locations where clearance imperatives exist, including the two 58.5 m spans at Springfield (refer Figure 14.7(a)), which cross both the Centenary Highway and the Springfield rail line.

Arches also can offer aesthetic advantages over trusses for long spans.

An arch is structurally efficient, and may also offer cost advantages for long spans.

Because of their aesthetic appeal, arches are often also adopted for shorter spans.



**Figure 14.7(a) – Springfield shared use bridge**



The longest arch bridge for pedestrians and cyclists in Queensland is the Goodwill Bridge across Brisbane River (refer Figure 14.7(b)). It has a main span of 102 m, demonstrating the efficiency of this bridge type for long spans.

**Figure 14.7(b) – Goodwill shared use bridge**



### **14.8 Cable supported bridges**

A cable supported bridge is the alternative when very long spans are involved. The most celebrated example in Queensland is the Kurilpa Bridge (refer Figure 2.2(a)), with its tensegrity arrangement.

Other examples are the Griffith University Bridge on the Gold Coast (refer Figure 5(a)), and the proposed Birdwood Road Bridge concept on the V1 at Greenslopes (refer Figure 8(a)).

A more conventional example is the Jack Pesch cable stay bridge at Indooroopilly (refer Figure 14.8). It has a main span of 167.5 m and a total length of 243 m over three spans (refer Section 7.3).

**Figure 14.8 – Jack Pesch cable stayed bridge at Indooroopilly**



Because of their dramatic aesthetic appeal, cable stay bridges are sometimes also adopted for shorter spans, especially:

- in prominent locations, and
- where there is a need to limit the superstructure depth.

## **15 Deck types**

### **15.1 General**

There is a wide range of deck types available including the following:

- Concrete slabs (refer Section 15.2), involving:
  - Precast concrete - (refer Section 15.2.1)
  - Precast concrete panel, with in-situ concrete infill - (refer Section 15.2.2)
  - In-situ concrete, with a variety of sacrificial formwork types - (refer Section 15.2.3).
- Aluminium - (refer Section 15.3)
- FRP panels - (refer Section 15.4)
- Asphalt - (refer Section 15.5)
- Timber - (refer Section 15.6)
- Recycled plastic - (refer Section 15.7)
- Miscellaneous composites - (refer Section 15.8), and
- Slip proof surfaces - (refer Section 15.9).

## **15.2 Concrete decks**

### **15.2.1 Precast concrete decks**

Precast concrete offers the opportunity to provide a deck thickness finely tuned to structural adequacy. This can offer advantages in terms of cost and minimisation of dead loads.

The precast deck at Eudlo Creek in Maroochydore (refer Figure 15.2.1) is only 80 mm thick, and achieved using composite reinforcement.

**Figure 15.2.1 – Eudlo Creek bridge (under construction) showing precast deck slabs**



The principal disadvantage of precast slabs is the need to provide an acceptable joint between each panel, especially where cyclist comfort is a concern. This can be achieved with careful detailing, as with the Jack Pesch Bridge shown in Figure 20.1(c). A special infill joint between adjacent panels was designed to provide a seamless deck surface.

### **15.2.2 Precast concrete panels with in-situ concrete infill decks**

The principal advantage of this type of deck is that temporary formwork can be avoided, either completely or substantially. An example can be seen in Figure 14.3.3(d), where the kerbs are also independent precast elements.

Another example, for prestressed concrete deck unit girders, is shown in Figure 15.2.2, where the kerbs form part of the precast concrete panel. The rationale is that it avoids temporary formwork to construct the kerbs. The underside of this bridge is shown in Figure 14.4.1.

In both cases the precast slab is the permanent formwork for the insitu component of the deck.

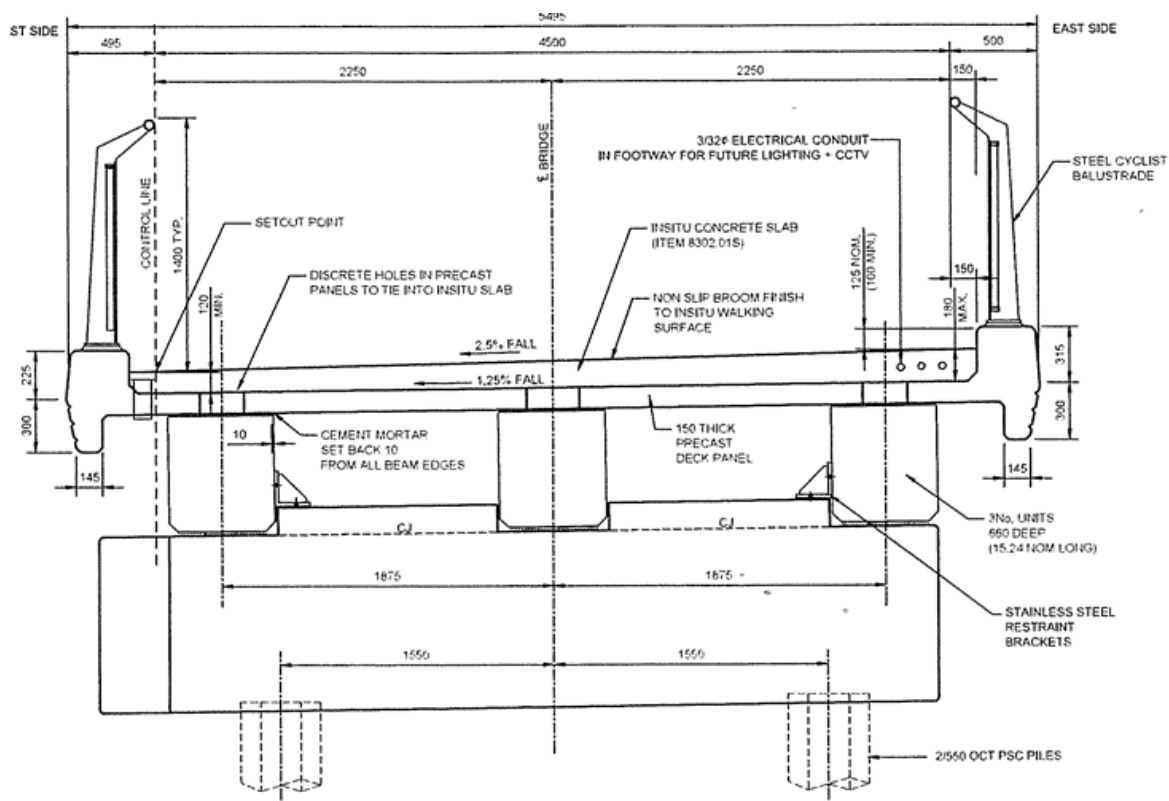

**Figure 15.2.2 – Type cross section at Schulz Canal**

Another variation is shown in Figure 14.4.2(b). A precast panel was used between the girders. Temporary formwork was used to create the cantilevered edges, but without kerbs. Omitting kerbs can be justified over water (refer Section 21.2).

A further variation of the precast panel option was shown in Figure 14.4.2(c). At Lewisham Street on the V1, the top flanges of the precast Super T-girders form part of the permanent formwork.

A disadvantage of using this deck type is that it can lead to deck thickness in excess of what is necessary for structural adequacy. This can be exacerbated by cross-fall considerations (refer Section 21.1 below). The excess concrete adds a direct cost, but also increases dead weight. This may impact on the size and cost of all other members.

### 15.2.3 In-situ concrete decks

In-situ concrete decks generally require formwork, which can be temporary, permanent (sacrificial), or some combination of both.

Temporary formwork can be expensive. There are usually some benefits in configuring the superstructure to suit sacrificial formwork, including reduced cost and improving the visual aspect of a bridge's underside.

The bridge deck shown in Figure 14.4.2(c) is a partial illustration of permanent formwork in that the troughs of the Super T-girders have been closed with sheets of fibre cement.

A more complete example is shown in Figure 15.2.3(a). All the gaps between the girders have been closed using fibre cement as permanent formwork.

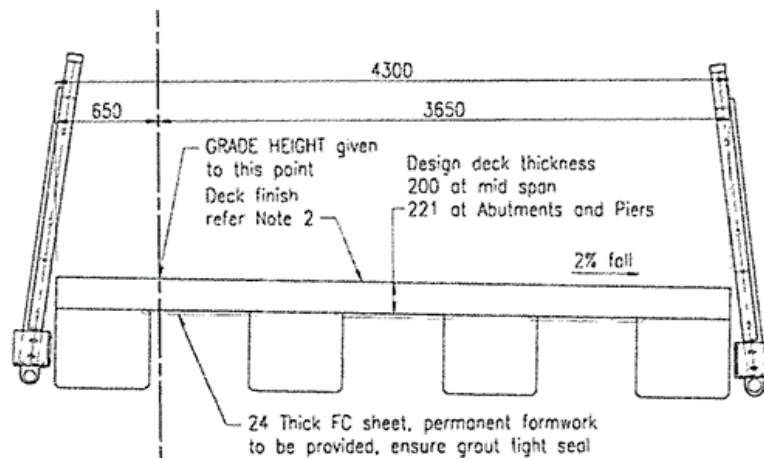
**Figure 15.2.3(a) – Moreton Bay Rail shared use bridge over Saltwater Creek**

Several varieties of profiled light gauge steel sacrificial formwork are available, although it is necessary to provide some form of corrosion protection. An example of this type of sacrificial formwork, from the steel truss bridge over Ekibin Creek at Greenslopes (refer Figure 14.6.2(a)), is shown in Figure 15.2.3(b). A similar sacrificial formwork was adopted for the Fearnley Street bridge (refer Figures 14.4.3(a) and 14.4.3(b)) and the Toowong Crossing (refer Figure 13.1).

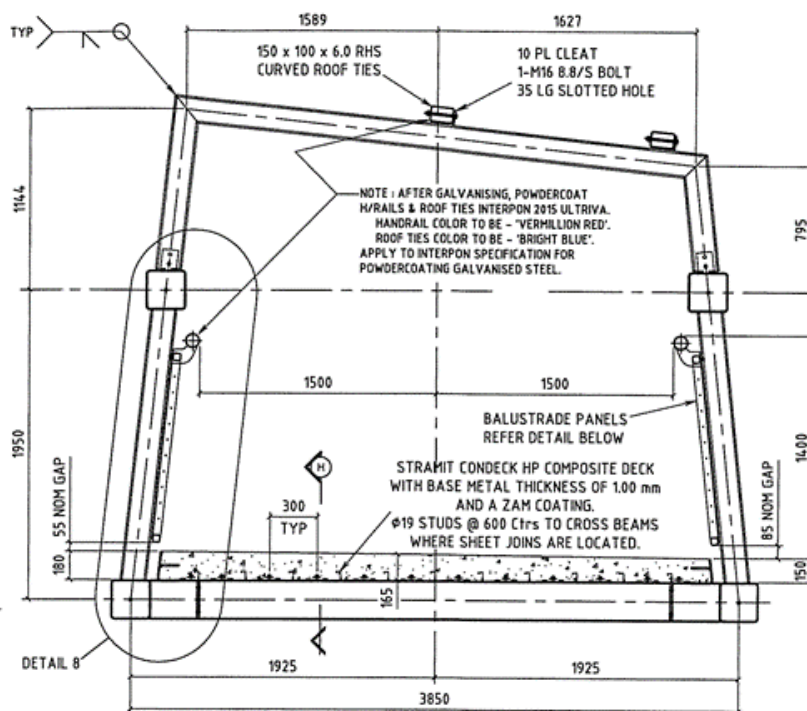
**Figure 15.2.3(b) – ZAM coated steel sacrificial formwork at Ekibin Creek on the V1**

All bridge configurations that allow sacrificial formwork, in lieu of temporary formwork, will promote value-for-money.

### 15.3 Aluminium decks

Aluminium decks are normally only used on bridges where the superstructure is also aluminium, as at Aeroglen in Cairns (refer Figure 15.3(a)). Jindalee Park shows a similar arrangement (refer Figure 14.6.3(a)).

**Figure 15.3(a) – Bridge over Saltwater Creek at Aeroglen, Cairns**



A plan view of the surface texture of the deck is shown in Figure 15.3(b). The cross section view is shown in Figure 15.3(c).

**Figure 15.3(b) – Textured deck surface on bridge at Aeroglen**



**Figure 15.3(c) – Section through aluminium deck panels at Aeroglen**



### 15.4 FRP decks

The bridge on the V1 shown in Figure 1.1 has an FRP deck (refer Figure 15.4). It has hollow section FRP pultrusions supporting FRP panels, with a thin slip proof surface (refer Section 15.9).

This deck has performed well, although at the time (circa 2010), it offered no direct cost benefit over a precast concrete deck. It was selected because of the need to occasionally remove the deck to inspect the deck's support structure and the bridge bearings. They were otherwise hidden from view and difficult to access. An FRP deck offered weight advantages over concrete, which means it can be more easily removed if necessary (refer Section 24). This lightness also meant that the truss could be delivered to site, and lifted into place fully fabricated, including the deck.

**Figure 15.4 – Section through London Street cycle bridge deck on the V1**

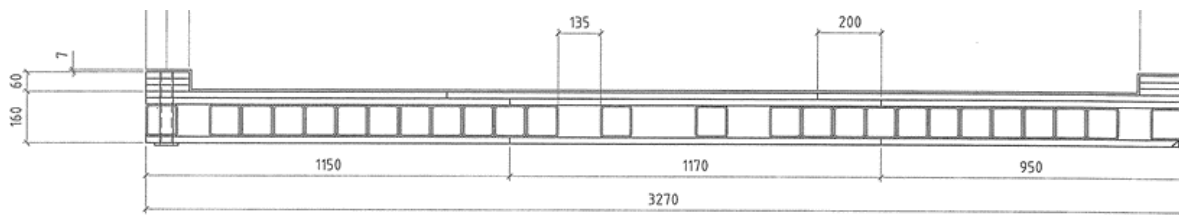

FRP flat panels can be difficult to source, although the pultrusions are readily available. Alternative composite flat panels are available (refer Section 15.8), but there is no current design industry or agency consensus that they offer the same performance characteristics as FRP. This issue is covered more fully in Section 25.

### 15.5 Asphalt deck surfacing

A bridge that has used asphalt as a deck surface is the Honeyeater Drive bridge (refer Figure 14.5.3.2). Asphalt is not recommended for use with FRP products for reasons associated with potential heat damage, explained in the Bridge Design Criteria.

### 15.6 Timber decks

Timber decking has previously been introduced in Figure 13.5, which illustrates its use on the Cultural Centre Boardwalk. Timber decking is also commonly used on smaller local authority bridges, usually in combination with steel supporting structures, as shown in Figures 15.6(a) and 15.6(b).

**Figure 15.6(a) – Timber deck on bridge over Bulimba Creek (Ditmas Street, Wishart)**





**Figure 15.6(b) – Timber deck on bridge over Bulimba Creek (Craig Street, Wishart)**



Timber decks, with their numerous gaps between planks, do not provide a smooth ride for cyclists, and have a tendency to become slippery, when wet.

There are, also, several durability issues with timber planks as a deck material. Firstly, only high quality hardwood is suitable, and replacement planks can be difficult to source.

Secondly, as the planks need to be replaced from time to time, the continual re-fixing of the planks can cause long term deterioration for the supporting members. This issue is illustrated in Figure 15.6(c), where timber planks are fixed, and re-fixed, directly into steel joists. This introduces corrosion opportunities. It may be an efficient means of construction, but whole-of-life value-for-money should be assessed.

**Figure 15.6(c) – Fixing for the timber deck on the bridge over Bulimba Creek (near Ditmas Street)**





### **15.7 Recycled plastic**

Recycled plastic deck planks are available (refer Figures 15.7(a) and 15.7(b)) and have been used in areas where a durable surface is required for relatively low volume pedestrian traffic.

**Figure 15.7(a) – Plan view of recycled plastic deck planks**



There is anecdotal evidence, however, that like timber planks they do not provide good rideability for cyclists. Their use for commuter cycling routes may not be appropriate.

**Figure 15.7(b) – Elevation view of recycled plastic deck planks**



The material is susceptible to fire damage (refer Section 13.8)

### **15.8 Miscellaneous composites**

Numerous ‘composite’ deck materials are currently marketed without specifically nominating the materials used, or their configuration within the product. Proprietary lines of this type are frequently marketed as ‘wood composites’ (waste timber and recycled plastic), or generically as ‘engineered cementitious composites’ (ECC). There is often no actual data on the product’s composition.

Designers must always satisfy themselves about:

- the suitability of any proprietary product offered, from a value-for-money perspective, and
- the composition of any brand for which no detailed material specification is readily available.

### **15.9 Slip resistant surfaces**

Examples of slip (skid) proof surfaces (refer Section 4.9.4 in this guideline) on pedestrian / cycle bridges include those shown in:

- Figures 14.3.3(a) and 14.3.3(b), where the steel deck at Falcon Street was surfaced
- Figure 14.6.3(a), where the aluminium deck at Jindalee Park was similarly treated
- Figure 1.1 (refer also Section 15.4), and
- Figure 5(a), on Griffith University Bridge.

As can be seen in Figure 15.9, which illustrates a section of the deck at Falcon Street, slip proof does not necessarily mean fail proof. Particular care should be taken if the slip resistant surfacing is also expected to form a protective anti-corrosion coating for a structural element.

**Figure 15.9 – Damage to anti-slip coating on steel deck at Falcon Street**



Providing a good quality, slip resistant surface should be carefully considered on curved decks.

### **15.10 Jointing**

Any necessary joints on the decks of pedestrian and cycle bridges require careful detailing, to avoid unnecessarily wide gaps and irregularities in the surface of the pathway. This could introduce a trip hazard for cyclists or diminish the ride-ability for cyclists.

## **16 Vehicle access**

Accommodation of an occasional vehicle on a pedestrian or cycle bridge should be considered, as failure to properly allow for necessary vehicle access can limit the public utility of such assets.

Vehicles accessing a bridge could be:

- tractor used for mowing parks
- ambulance
- maintenance truck or utility

- underbridge inspection unit
- fire truck, and
- unauthorised car.

Providing preventative measures, like bollards, does not prevent owners or designers being responsible for considering the risk of occasional vehicle entry (refer Figure 16 below).

**Figure 16 – Bridge deck damage due to inappropriate vehicle access**



Where it is considered possible for a light vehicle to access a bridge, the Bridge Code nominates a design concentrated load (refer Section 17.3.2).

The Bridge Code also provides for the agency controlling the bridge design to specify additional requirements so maintenance, inspection, or emergency vehicles can access the bridge. The Bridge Design Criteria nominates the design vehicle load to adopt in certain circumstances (refer Section 17.3.3).

None of these provisions are mandatory, so it is possible for a bridge to be designed without any allowance for vehicle loads. To prevent vehicle access, bollards and load limit warning signage are frequently installed on bridge approaches. This does not completely preclude unexpected vehicle access, for which the bridge was not designed.

It is recommended all bridges be designed to accommodate a design vehicle, as defined in Section 17. The load chosen should be a realistic assessment of future use. Owners and designers should not ignore adopting a design vehicle, as this will result in a bridge unsuitable for all its intended purposes.

Neither should a heavy design vehicle be adopted, that has no probability of ever mounting the bridge. This often adds to unnecessary costs.

The vehicle adopted for design of the bridge should be clearly shown on the project drawings.

## **17 Loads**

### **17.1 General**

The loads discussed here are only those that specifically relate to the design of cyclist or pedestrian bridges. These are principally:

- pedestrian and cyclist live load



- occasional vehicle loads, expressed as either a concentrated load or design vehicle
- lateral load, and
- loads on bridge edge barriers, such as railings, balustrades and anti-throw screens.

Collision impact is considered in Section 18.

Other forces such as wind load, earth pressure, water flow (refer Section 21.4), seismic activity, and the like, which are routinely considered in the design of any bridge, are not dealt with in this review.

All elements in a pedestrian or cycle bridge should be proportioned to ensure that unnecessary dead loads are avoided.

## 17.2 Pedestrian and cycle path loads

The Bridge Code stipulates that pedestrian and cyclist path bridges, up to 100 m long, shall be designed for a live load varying between 4 – 5 kPa, determined in accordance with Figure 17.2.

**Figure 17.2 – Pedestrian and cycle bridge live loads from AS(/NZS) 5100:2017**

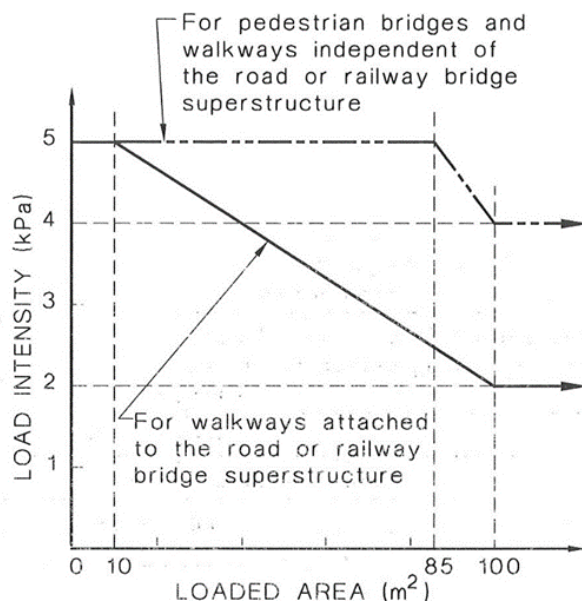

It is important to ensure that the appropriate load is applied. A load lower than 5 kPa is appropriate for loaded areas greater than 85 m<sup>2</sup>. This is efficient, and minimises costs.

A live load of 5 kPa shall be adopted where the agency responsible for bridge design considers that crowd loading is possible. Crowd loading can be appropriate in highly urbanised areas or in proximity to major events venues.

The Bridge Code stipulates that for the purposes of ultimate limit state (ULS) design, a load factor of 1.5 shall be applied.

## 17.3 Vehicle loads

### 17.3.1 General

The possibility of a vehicle occasionally crossing a pedestrian or cycle bridge should be carefully evaluated (Refer Section 16).

The range of nominated potential vehicle loads is wide and spread over a variety of references. The designer should consult with asset owners to determine their specific requirement. At least one of the following options should be adopted.

### **17.3.2 Bridge Design Code, AS/(NZS) 5100:2017**

Where it is possible for a light vehicle not exceeding 4.5 tonne to access a bridge, the Bridge Code stipulates that it shall be designed to carry a concentrated load of at least 20 kN on an area of 200 mm x 200 mm (i.e. 0.04 m<sup>2</sup>).

The Bridge Code also provides for the agency controlling design of the bridge to specify additional requirements, where it is required that maintenance, inspection, or emergency vehicles can access the bridge.

### **17.3.3 The Department of Transport and Main Roads**

The Bridge Design Criteria references the provisions of the Bridge Code (refer to Section 17.3.2 above). It stipulates that a minimum M13.5 design truck vehicle load (in accordance with the superseded AS 5100:2004) shall be applied:

- where a bridge has a width between kerbs greater than 3.5 m, and
- inspection and maintenance will be carried out from the bridge.

This issue should be carefully considered, as this is a relatively heavy vehicle with cost implications. This decision also has ramifications for barrier loads (refer to Section 17.5 of this guideline).

### **17.3.4 Australian Standards**

The Australian Standard, AS 1170.1 (refer Section 4.9.2 of this guideline), which covers design loads for general structures, contains provisions for the following alternative vehicles:

- Light Vehicle, not exceeding 2.5 tonne: 13 kN, and
- Medium Vehicle, not exceeding 10.0 tonne: 31 kN applied over an area of 0.025 m<sup>2</sup>.

An Appendix of AS 1170.1 also includes provision for 'Farm machinery', with a point load of 25 kN on an area of 0.56 m<sup>2</sup>.

### **17.3.5 Brisbane City Council (BCC)**

In its Planning Scheme (refer Section 4.6 of this guideline), BCC provides several other options for maintenance vehicles, and requires one be adopted. These are as follows:

- for bridges with an access clear width not greater than 1.5 m, a 1.8 tonne GVM vehicle, and
- for greater access clear width, either the vehicle described above, a 2.5 tonne GVM vehicle, or a 6.1 tonne GVM vehicle.

However, the wheel load from a BCC 6.1 tonne GVM vehicle is the same as for the Bridge Code's nominal 4.5 tonne vehicle.

## **17.4 Lateral loads**

The Bridge Design Criteria requires that a critical load case for a new stand-alone 'footbridge' be a lateral load of 500 kN.



## **17.5 Barrier loads**

These are covered extensively in Part 2 of the Bridge Code. The Code provides the requirements for the structural sufficiency of post, rails and balustrades, when combined to create the edge barriers on a pedestrian or cycle bridge.

In the Bridge Code, two load cases apply to the structural design of active user barriers. The first is a normal requirement, and an alternative case where crowd loading or panic conditions could apply. The distinction must be considered. The panic condition is considerably more onerous than the alternative, and will substantially increase the cost of any barriers. It should not be adopted unless specifically prescribed by the responsible agency.

The Bridge Design Criteria require that whenever the M13.5 maintenance truck provision is invoked (refer Clause 17.3.3) the panic load condition shall be applied to the bridge barrier. This will have considerable impact on barrier cost. Consequently, the M13.5 vehicle provision should not be arbitrarily adopted.

Deflection limits on barriers also apply in the Bridge Code.

In barrier design the ULS load factor is 1.8, and the SLS load factor is 1.0.

## **18 Collision impact**

### **18.1 Road vehicle**

In the Bridge Code, for piers within the clear zone, a ULS design collision load of 2700 kN is specified, acting in any horizontal direction, and applied at a distance 1.2 m above ground level.

Where applicable, this load is generally the controlling design parameter for pedestrian and cycle bridge piers. The Bridge Code acknowledges that this does not represent a head on collision.

The Bridge Design Criteria includes an additional provision. It increases the collision load to 4000 kN for single column piers, which comprises a doubling of the collision load specified in the superseded *Bridge Design Code AS 5100:2004*. The Bridge Design Criteria considers a blade wall to be a single column.

This requirement invariably increases the size of piers for active user bridges, and their associated foundations, with a consequent increase in cost. The considered positioning of piers outside the clear zone will generally reduce costs if the application of collision load requirements can be avoided.

### **18.2 Rail vehicle**

In its CIVIL-SR-006 Technical Requirement (refer Section 4.5 in this guideline), QR prefer that all 'footbridges' have a single clear span over existing and future rail tracks. It only permits columns and piers between tracks at platforms, '*unless otherwise agreed with Queensland Rail*'. The design collision loads for 'non-station footbridges' are those loads specified in accordance with the Bridge Code.

### **18.3 Waterway traffic / ship collision**

The Bridge Code considers the possibility of a ship collision, and also references the USA National Bridge Design Code *AASHTO LRFD Bridge Design Specification* (refer Section 4.2 in this guideline).

The Bridge Design Criteria also considers the requirements for protection from ship collision, including reference to the *AASHTO LRFD Bridge Design Specification* (refer Section 4.3 in this guideline).

Both documents concede that the harbour master, port authority, or relevant authority must be consulted to determine the appropriate parameters.

## **19 Serviceability**

### **19.1 General**

Deflection limits are a significant design criterion and should be considered (refer Section 19.2). In addition, if pedestrians exert forces that mimic frequencies close to the natural frequency of a bridge, then a resonance, or vibratory response, can occur. This can be an unsettling experience for users and should be avoided (refer Section 19.3).

### **19.2 Static deflections**

A maximum allowable vertical deflection for the serviceability limit state live load is specified in the Bridge Code; i.e. 1/600 of the span or 1/300 of a cantilever projection. Some materials, like timber, aluminium or FRP may find the Bridge Code requirement challenging. There may be a case for a relaxation for some crossing types where minimum clearance criteria do not apply.

In the USA, the *National Bridge Design Code (AASHTO)* defers to the *Guide for Design of Pedestrian Bridges (AASHTO 2009)*. This suggests that the deflection due to the un-factored live loading should not exceed 1/360 of the span length (1/220 for a cantilever).

The Bridge Code criteria should generally be adopted over transportation corridors such as roads and railways. The AASHTO criteria could be considered where the clearance envelope is not infringed. For situations where infringement on a clearance envelope is not an issue, the AASHTO criteria could be adopted.

### **19.3 Dynamic behaviour**

Generally, relatively light bridges will be more susceptible to vibrations than heavier ones and there is some advantage in avoiding 'optimistic' span to depth ratios. For example, a pedestrian crossing the bridges in Figure 5(a) or Figure 14.5.1 can experience a mild, albeit disconcerting, 'flutter'. These can be ameliorated by installing damping devices, but not without cost. This phenomenon was again highlighted in 2000, by the lateral vibration identified at the Millennium Bridge, London. In the USA, the *Guide for the Design of Pedestrian Bridges (AASHTO 2009)* contains a comment that the 'vibration problems' experienced by the Millennium Bridge led to '*many publications in the technical literature, primarily in Europe, on this topic*'. The guide goes on to comment that notwithstanding '*this large body of knowledge, it does not appear there has been a convergence toward one method of evaluation, or development of any specification that adequately covers this issue*'. This situation frequently leaves designers obliged to adopt alternative guidelines, and those of the International Federation for Structural Concrete (refer Section 4.11 in this guideline) are a common design reference.

National bridge codes do not always define dynamic load models for pedestrians. Most suggest a range of natural frequencies to avoid, if possible. Some suggest methods for assessing the natural frequencies of bridge decks and substructures. In Australia, the Bridge Code stipulates that pedestrian bridges with resonant frequencies for vertical vibration less than 5 Hz should be investigated as a serviceability limit state. The nominated design load is a single pedestrian, with a weight of 700N, crossing the bridge at an average walking speed of 1.75 – 2.5 footfalls per second. The maximum vertical acceleration must fall within certain defined limits when compared to the first mode flexural frequency. Special consideration is also required when the fundamental frequency of horizontal vibration is less than 1.5 Hz.

The Bridge Code does not provide acceptance criteria for bridges with spans in excess of 100 m, or suspension or cable bridges, which require 'special investigations'.

## 20 Barriers

### 20.1 General

The particular active user modes (pedestrians, cyclists, disabled users and students) all have special handrail requirements, and these are subtly different in the various design references. These need to be carefully considered when determining the cross section of the active user bridge.

Where appropriate, handrails and balustrades offer the designer an opportunity to enhance the aesthetics of an active user bridge. Equally, poor detailing can detract significantly from its visual impact.

In certain circumstances, designers can consider incorporating barriers as structural elements, as shown in Figure 20.1(a), where the railings double as lattice trusses supporting the bridge deck.

**Figure 20.1(a) – Lattice truss balustrade**



The Bridge Code covers the general requirements for railings, balustrades, and kerbs on discrete pedestrian and cycle bridges.

It is common for bespoke barrier arrangements to be developed for a particular site. This can often be justified on the basis of aesthetic amenity where a bridge is highly visible.

Nevertheless, this can be a costly decision. For example, at the Moggill Road Cycle Bridge the balustrade cost over \$0.5M, about 9 % of the construction cost. Stainless steel railing and bespoke posts were used (refer Figure 20.1(b)).



**Figure 20.1(b) – Bespoke balustrade at Moggill Road cycle bridge**



In this instance, the expenditure on high quality materials and project specific fabrication could be defended on the basis that the bridge is highly visible. Nevertheless, a reduction in the cost of these balustrades could possibly have been achieved. The costs of adopting special materials and non-standard profiles to enhance appearance in less prominent location should always be considered.

An example of a more conventional handrail is the one adopted at the Jack Pesch Bridge (refer Figure 20.1(c)). Simplicity is very often an appropriate, cost effective approach.

**Figure 20.1(c) – Balustrade at Jack Pesch Bridge, Indooroopilly**

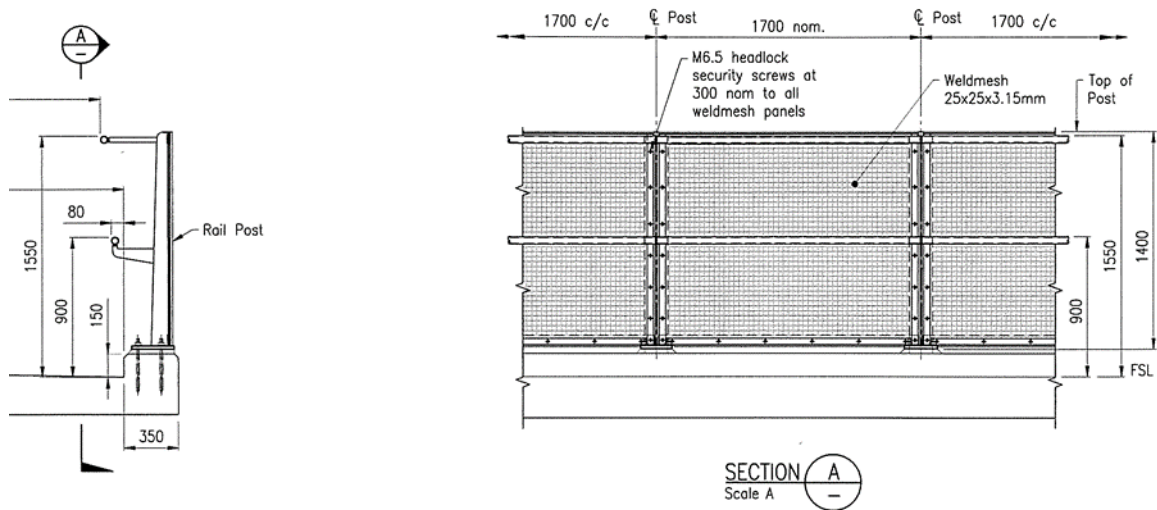

In some locations, consideration can be given to using a proprietary barrier that might offer further cost savings. A recent project suggests that considerable savings are possible. The barriers on the access walkways, ramps and stairs for the Cairns Connect Bridge were designed as bespoke items (refer Figure 20.1(d)).

**Figure 20.1(d) – Bespoke barrier design for the Cairns Connect bridge**

There were approximately 800 m of posts, railing and mesh balustrade barrier required on the bridge. At the time of construction (circa 2014), proprietary barriers (refer Figure 20.1(e)) were substituted for the 'as designed' items, at an estimated cost saving of \$200,000.

**Figure 20.1(e) – Installed proprietary barrier for the Cairns Connect bridge**

Such substitutions will not always be appropriate, but can occasionally offer considerable savings.

The design loads for barriers are discussed in Section 17.5.



## **20.2 Railings**

Consideration should be given to the specific requirements for railings, as unnecessary provision can significantly increase costs.

The Bridge Code requires that railings have a minimum height from walkway level of 1.2 m for pedestrians, and 1.4 m for cyclists.

Part 6A also recommends that the railing height for cyclists be 1.4 m, although it does allow a minimum height of 1.2 m.

The height endorsed in the Bridge Design Criteria is also 1.4 m (above walkway level).

Generally, the disability access standard requires that a handrail be provided for mobility-impaired users, with a height above the trafficable surface of 865 mm to 1000 mm (refer Section 4.9.3).

The Building Code has similar handrail height requirements – 1.0 m for grades less than 1 in 20, and 865 mm for grades steeper than 1 in 20 (refer Section 4.10). For stairs, these measures are taken from the nosing of each tread.

The southern approach ramp at the Toowong Crossing (refer Figure 12.2) is on a facility for cyclists, but access by pedestrians and mobility impaired users is also permitted. Two handrails were provided, nominally at heights of 1.0 metres and 1.4 metres.

If a high proportion of users are short (not necessarily children), the access standard (refer Section 4.9.3) stipulates two handrails. The lower should be placed at a height between 665 mm and 700 mm and the top rail between 865 mm and 900 mm. The DETE Criteria (refer Section 4.8) for primary school students (who are, generally, by definition 'short') also requires that two handrails be provided. These can be nominally at heights of 700 mm and 900 mm, subject to compliance with 'Building Act requirements'. For primary schools, the Building Code (refer Section 4.7) requires one handrail fixed at a height of not less than 865 mm, and a second handrail fixed at a height between 665 mm and 750 mm.

Two bridges over major roads with school facilities situated on both sides of the thoroughfare are at Redcliffe and Mabel Park. The bridge at Redcliffe (over Oxley Avenue) involved linking split campuses of the same high school. As this involved secondary school students, the crossing was only provided with a single handrail at a nominal height of 1.0 m. A second crossing at Mabel Park enables safe access across Paradise Road for students at two schools; one a high school and the other a primary school. With a need to cater for students of all ages the Mabel Park facility has two handrails; one 700 mm above floor level, the other at a height of 900 mm. Where two handrails are provided to cater for joint use, it is important to ensure that the possibility of head or neck entrapment is avoided.

## **20.3 Balustrades**

Railings and balustrades for cyclists should preclude the possibility of bicycle entrapment, particularly panniers. For this reason, balustrade posts are often inclined inwards (refer Figures 20.1(b) and (c)). Bridges on the department's bikeways routinely incorporate a specially designed railing with vertical, recessed balusters (refer Figure 14.4.2(b)). Both options are based on details given in the superseded Part 14, which is not reproduced in Part 6A (refer Section 4.3).

Some designers prefer vertical, and even outwardly inclined balustrades.

The Bridge Code indicates a preference for:

- vertical, or near vertical balusters, or
- solid-face balustrade, without climbing footholds.

The Building Code (refer Section 4.10) describes a foothold as *'any horizontal or near horizontal element between 150 mm and 760 mm above the floor'*.

In the Bridge Code, it is suggested that the clear separation between vertical balusters be less than 125 mm. This accords with the Building Code (refer Section 4.10), which requires that a balustrade *'not permit a 125 mm sphere to pass through it'*. The Building Code also allows properly tensioned horizontal wire balustrades at a maximum spacing of 100 mm. If their climbing potential can be overcome, these can be used to good effect where it is desirable to:

- maximise visibility through the balustrade, and
- achieve a modern architectural aesthetic.

The Bridge Code requires a maximum clearance between top of kerb and the bottom railing of any balustrade (refer also Section 20.4).

## **20.4 Kerbs**

Kerbs are necessary on bridges that cross transportation corridors to:

- prevent discarded objects falling onto the road or railway below, and
- divert stormwater (refer Section 21.2).

Kerbs are not always necessary and they can be an expensive addition to a bridge deck. For example, omission of kerbs can be considered over a watercourse, subject to environmental considerations.

If required, the Bridge Code stipulates that a continuous kerb with a minimum height of 100 mm be provided. This is not compatible with bicycles or wheel chairs, the criteria for which specify lesser values. Where the 30% provision for walkway access gradients and ramp intervals is invoked, a kerb is mandatory. AS 1428, the code for disabled access and mobility (refer Section 4.9.3 in this guideline), suggests the height of this kerb should fall in the range 65 – 75 mm, which would also suits the requirement for bicycle pedal clearance.

A high kerb may also be considered sufficient to restrain errant occasional vehicles, which might access a bridge. While this may be an additional expense, it might save the cost of providing a barrier that requires the crowd load (refer Section 17.5), rather than the normal case.

## **21 Drainage and flood immunity**

### **21.1 Cross-fall**

Common practice is to provide cross-fall on the deck of pedestrian and cycle bridges similar to that on a roadway; i.e. 3%. This may be excessive and, where there is no risk of aquaplaning on pedestrian or cycle bridges, slighter cross-falls may be sufficient (in the range 0.5 – 1.5%).

It is important to minimise cross-fall, especially for concrete decks. It can lead to excessive deck thickness if the general slope of the superstructure elements does not match the cross-fall. For example, a 3% cross-fall over 4 m can add 120 mm to the depth of slab. This adds dead load and cost (both direct and indirect).

## 21.2 Kerb

Kerbs should be provided over transport corridors where required (refer Section 20.4).

Kerbs need not be provided in other locations, such as over a watercourse, if there is no environmental requirement.

If water is to discharge directly from the deck (as in Figure 14.4.2(b)) then an overhang, with a drip groove, should be provided. This helps to avoid staining, or corrosion of any adjacent girders.

## 21.3 Scuppers

Sufficient scuppers should be provided to efficiently drain the deck. If there is an environmental requirement, the scuppers should be connected to a pipe system and discharged to an approved outlet. Pipework under bridges can be unsightly, and where visible to the public, an attempt should be made to provide a visually sensitive treatment.

## 21.4 Flood immunity

The Bridge Code deals with the general requirements for Waterways and Flood Design, and includes:

*'For pedestrian and cyclist path bridges, the flood immunity and SLS ARI shall be 10 to 50 years unless specified otherwise by the relevant authority.'*

In this context, the *'flood immunity'* level is considered to be at or below the soffit level of the bridge.

The Bridge Design Criteria defers to the *Road Drainage Manual (RDM)*, which doesn't refer to pedestrian / cycle bridges specifically. However, it splits the department's assets into major and minor categories (ARI 50 and 10 years respectively).

A 10 year ARI immunity is considered sufficient in most circumstances except:

- for major pedestrian or cycle bridges over large waterways
- where specific afflux constraints apply
- where particular agency requirements are invoked, and
- unless greater protection can be provided at marginal cost.

Bridges over watercourses must comply with the Bridge Code requirements for forces associated with floodwaters, debris loads, and log impact. When selecting a bridge type over a watercourse, consider whether it is likely to attract debris and log impact. Options that avoid both these problems may offer value-for-money, compared to alternatives that don't.

Some agencies have developed friable barriers, designed to collapse under debris load.

## 22 Anti-throw screens

The Bridge Code recognises the risk of objects being inadvertently dropped or deliberately thrown from cycle or pedestrian bridges onto vehicles below. The Code requires that protection screens for errant objects be provided *'where required by the relevant authority'*. The department has issued a policy and companion technical guidelines (refer Section 4.4.6 and Table 4.1 in this guideline). These ATS Guidelines, which strengthen the Bridge Code provisions, include an assessment tool that allows designers to determine the need for an anti-throw screen.

In many instances, anti-throw screens are not required and may be an unnecessary additional cost. They should not be adopted arbitrarily, as they can present aesthetic challenges (refer Section 5).

To prevent objects falling or being thrown from bridges serving active users, and where deemed necessary by a prescribed risk analysis, the Bridge Code requires one of the following protection measures:

- Full enclosure.
- Solid opaque parapet wall with a minimum height of 2.4 m.
- Protection screens, which:
  - have a minimum height of 3.0 m above walkway surface (increased under the ATS Guidelines to 3.5 m)
  - have mesh aperture not greater than 50 mm x 50 mm (25 mm x 25 mm over railways), also modified under the ATS Guidelines
  - are setback at least 350 mm immediately adjacent to roadways, and
  - extend at least 6 m beyond the edge of trafficked lanes below (9 m beyond the centreline of a rail track), further modified under the department's ATS Guidelines.

Where a protection screen is immediately adjacent to a facility for active users (as on a pedestrian or cycle bridge), it may curve back over the facility to provide greater protection. This is provided certain geometrical conditions are satisfied, as shown in Figure 22(a), although the department has modified the Bridge Code parameters.

**Figure 22(a) – Protection screens (from the Bridge Design Code, AS(/NZS) 5100:2017)**

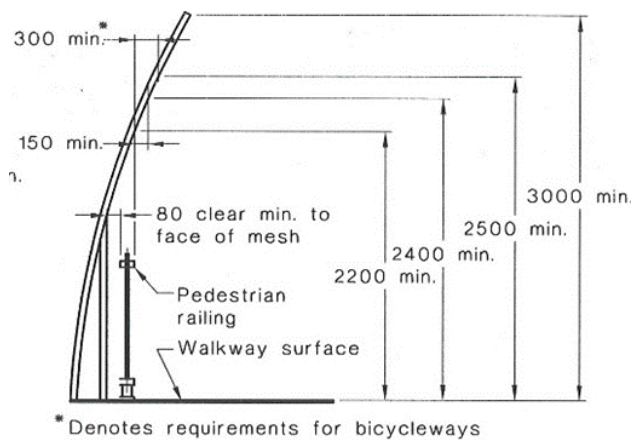

As noted above, the ATS Guidelines (refer Section 4.4.6) strengthen the Bridge Code requirements, in that:

- the mesh aperture must be capable of retaining a 25 mm diameter sphere in all cases
- gaps in screen panels that would allow flat projectiles to pass (e.g. sign faces) are not permitted
- the recommended height of screen panels is 3.5 m, and
- screens should extend at least 10 m past the edge of trafficked lanes.

The decision to install protection screens will always be an expensive one, and they should not be adopted without due consideration. Consequently, the ATS Guidelines contain a risk assessment methodology based on a questionnaire about local area and traffic conditions. The points obtained from the questionnaire (R1) are modified by a speed multiplier (R2) and a traffic multiplier (R3) for the



underpass road, to take account of the greater risk involved in crossing roads with faster speeds and higher traffic volumes. The final risk assessment score is calculated as:

$R1 \times R2 \times R3$ , which is interpreted as:

- low risk - 0 to 30
- medium risk - 30 to 60
- high risk - greater than 60.

Recent data is available on the cost impact of anti-throw screens. When the cycle bridge over Lewisham Street and Norman Creek on the V1 at Greenslopes was completed in early 2016, it incorporated:

- anti-throw screens for 35 m over Lewisham Street, and
- balustrade for the remaining 52.5 m (refer to Figure 22(b)).

**Figure 22(b) – Lewisham Street cycle bridge**



The cost for the anti-throw screen was \$117,462 or \$3,356 / m of bridge. The balustrade, on both sides, for the remaining sections of bridge and relieving slabs cost \$75,283, or \$1,434 / m about 40% of the cost to provide the anti-throw screens. Consequently, the net cost of providing the anti-throw screens was \$67,270 ( $\$3,356 - \$1,434 \times 35$ ). If the risk is high, this may be good value-for-money. A robust risk assessment should be completed before designing for anti-throw screens.

## **23 Foundations**

### **23.1 General**

Foundations for pedestrian and cycle bridges normally comprise high level spread footings or pile footings. Because of the relatively light loads imposed to foundations by these bridges, there is an opportunity to adopt smaller and alternative foundations than would apply to a road bridge, which is not always reflected in the design references. The Bridge Design Criteria, however, precludes the use of numerous pile types that may be suitable for pedestrian and cycle bridges. Consequently, designers proposing proscribed foundation systems should seek agreement for alternative proposals early in the development process (refer Section 4.1).

### 23.2 Spread footings

In the Bridge Design Criteria there is a requirement that abutments be founded on piles, in the absence of competent rock. This may not be cost effective for some short span pedestrian or cycle bridges, where scour is not an issue.

### 23.3 Driven piles

The preferred driven pile allowed by the Bridge Design Criteria is the standard, 550 mm PSC octagonal pile (refer Standard Drawing 2021). This is adequate in most circumstances, and a smaller, less expensive pile may be appropriate for many pedestrian bridges.

The Bridge Design Criteria excludes a number of other driven pile types, although some bridges included in this technical guideline have been constructed, by other authorities, with piles systems that do not, technically, meet the Bridge Design Criteria (refer Section 4.1).

### 23.4 Cast in place piles

The Bridge Design Criteria stipulates that the '*minimum internal diameter of cast-in-place piles for traffic bridge foundations shall be 900 mm*'. Given the loads normally associated with pedestrian and cyclist bridges, this is more than adequate in most circumstances.

The Bridge Design Criteria make a dispensation for 'short span, narrow footbridges not over road or rail corridor', where the spans are less than 10 m and the width less than 3.4 m. In this case, the pile may have a minimum diameter of 600 mm in accordance with MRTS63A *Piles for Ancillary Structures*. It is considered that the 900 diameter minimum limit can impose additional cost on active transport bridges. As a smaller pile will often suffice, consideration should be given to suggesting such options at the bridge fixing stage (refer Section 4.1).

**Figure 23.4 – 900 diameter piles for Lewisham Street cycle bridge on V1, Brisbane**



## 24 Ease of maintenance

Value-for-money will not be promoted if future maintenance activities at the bridge site are difficult to carry out. These activities can include:

- replacement of bearings
- painting of steelwork
- repair of spalled concrete, and
- replacement of bridge decks (for example timber or FRP).

Consider the extensive temporary works required in 2017 for the Merivale Rail Bridge (refer Figure 24). This is a painted steel arch bridge opened in 1978, so it lasted a creditable 40 years before needing a major repaint.

**Figure 24 – Maintenance work at Merivale Rail bridge**



Designers should, nevertheless, resist the temptation to assume these work items are always in the distant future. As an example, repainting of the Griffith University Bridge (refer Figure 5(a)) was being planned only ten years after the bridge was completed.

When adopting bridge types, materials, and durability treatments, consider how easily future maintenance and repair works will be carried out. If durability isn't considered, then the present value of the bridge over its design life will be substantially increased.



For the bridge shown in Figure 1.1, the designers provided a relatively light deck (refer Section 15.4) that can be readily removed. This allows easy access to bearings and cross beams that would otherwise be difficult to reach because of adverse site constraints. A gantry rail was provided to facilitate removal of the deck panels.

## 25 Innovations

Pedestrian and cycle bridges lend themselves to innovative solutions.

Wide flange PSC I girders are becoming available and these may offer advantages.

There is a need for a single span precast girder that can provide a bridge with a 3 m width between hand rails.

Precast concrete deck spans are being offered, which may provide advantages, and introduce the general concept of modular construction. Careful detailing of spans and curves for long bridges can offer opportunities to consider bespoke modular solutions under certain circumstances. An example is the Auke Vleerstraat Bridge at Enschede in The Netherlands, shown during construction in Figure 25.

**Figure 25 – Auke Vleerstraat bridge at Enschede (The Netherlands), under construction**



As noted in Section 13.5 in this guideline, timber is becoming available in more technologically enhanced forms. Stress-Laminated Timber (SLT) for plate, T-beam, and cellular decks offer opportunities in certain circumstances.

FRP offers some advantages, particularly in reducing dead loads. Although span lengths using this material are currently limited to about 25 m, longer spans can be expected in the future. While potentially offering durability advantages, these will need to be demonstrated over time. Serviceability constraints may also limit the applicability of this material.

There appears to be no reliable FRP deck plate product in the local market. There is scope for a high quality FRP deck panel.

Weathering steel could be a durable alternative to galvanised or painted steel in some situations, and this product is marketed in Queensland.

## 26 Recommendations

Value-for-money can be achieved if designers provide a bridge that minimises the initial costs of development and implementation, while producing a durable bridge that suits the ease of maintenance conditions prevalent at the site.

Designers should consider the following suggestions:

- plan ahead
- execute planning intelligently
- be cost conscious
- consider future maintenance requirements
- design for 50 years, but plan for a further 50 years of ongoing maintenance
- adopt elegant simplicity as a style
- remember, it's not a road bridge; use 'standard' solutions more efficiently
- use lower bound of live load envelope when appropriate
- optimise the user envelope to avoid redundant width
- investigate all possible options and attempt to select the most appropriate design
- avoid widely uneven span lengths
- adopt realistic criteria for occasional vehicle loads
- use realistic serviceability criteria
- be flexible about delivery options
- closed steel sections inhibit maintenance inspections
- optimise ramp grades
- minimise the length of access ramps where possible
- consider the length of galvanising baths when selecting steel member lengths
- carefully select joint details for galvanised members
- minimise concrete deck thicknesses
- optimise composite action for concrete decks
- use sacrificial formwork, where possible
- avoid kerbs, where possible
- adopt appropriate clearances
- optimise element sizes to match material classes
- avoid arbitrary use of anti-throw screens
- match pile size to structural requirements



- simplify barrier designs
- use cost effective proprietary items, when appropriate
- avoid debris loads and log impact for watercourse crossings, and
- where possible avoid piers in the clear zone, to minimise collision load requirements.

