

Technical Specification

**Transport and Main Roads Specifications
MRTS03 Drainage, Retaining Structures and Protective
Treatments**

January 2019

Copyright

© The State of Queensland (Department of Transport and Main Roads) 2019.

Licence



This work is licensed by the State of Queensland (Department of Transport and Main Roads) under a Creative Commons Attribution (CC BY) 4.0 International licence.

CC BY licence summary statement

In essence, you are free to copy, communicate and adapt this work, as long as you attribute the work to the State of Queensland (Department of Transport and Main Roads). To view a copy of this licence, visit: <https://creativecommons.org/licenses/by/4.0/>

Translating and interpreting assistance



The Queensland Government is committed to providing accessible services to Queenslanders from all cultural and linguistic backgrounds. If you have difficulty understanding this publication and need a translator, please call the Translating and Interpreting Service (TIS National) on 13 14 50 and ask them to telephone the Queensland Department of Transport and Main Roads on 13 74 68.

Disclaimer

While every care has been taken in preparing this publication, the State of Queensland accepts no responsibility for decisions or actions taken as a result of any data, information, statement or advice, expressed or implied, contained within. To the best of our knowledge, the content was correct at the time of publishing.

Feedback

Please send your feedback regarding this document to: tmr.techdocs@tmr.qld.gov.au

Contents

- 1 Introduction1**
- 2 Definition of terms1**
- 3 References.....2**
- 4 Standard test methods4**
- 5 Quality system requirements4**
 - 5.1 Hold Points, Witness Points and Milestones 4
 - 5.2 Construction procedures..... 6
 - 5.3 Compliance testing 6
 - 5.4 Testing frequency 6
- 6 General material and construction requirements7**
 - 6.1 Concrete and reinforcing steel..... 7
 - 6.2 Cement mortar 7
 - 6.3 Cement grout 7
 - 6.4 Grates, cover and frames 7
 - 6.5 Excavation and backfilling 8
 - 6.6 Proprietary products 8
- 7 Geometric tolerances for culverts8**
 - 7.1 General 8
 - 7.2 Horizontal tolerances 8
 - 7.3 Vertical tolerances 8
- 8 Removal or demolition of culverts and culvert end structures9**
 - 8.1 General 9
 - 8.2 Description 9
- 9 Removal / demolition of kerbs and channels and concrete slabs.....9**
 - 9.1 General 9
 - 9.2 Description 9
- 10 Removal / demolition of gullies and access chambers9**
 - 10.1 General 9
 - 10.2 Description 10
- 11 Supply of precast and preformed culvert and drainage trough components 10**
 - 11.1 General 10
 - 11.2 Material requirements 10
- 12 Installation of precast and preformed culvert components 11**
 - 12.1 General 11
 - 12.2 Material requirements 11
 - 12.3 Construction..... 12
 - 12.3.1 *General*..... 12
 - 12.3.2 *Bedding of culvert components* 12

12.3.3	<i>Assembling culvert components</i>	12
12.3.4	<i>Laying and jointing culvert components</i>	13
12.3.5	<i>Special requirements for concrete pipe culvert components</i>	13
12.3.6	<i>Special requirements for concrete box culvert components</i>	14
12.3.7	<i>Special requirements for corrugated steel culvert components</i>	14
12.3.8	<i>Special requirements for corrugated pipe, pipe-arch and arch culverts</i>	14
12.3.9	<i>Cutting culvert components</i>	14
12.3.10	<i>Backfilling of culverts</i>	15
13	Installation of precast and preformed drainage trough components	15
13.1	General	15
13.2	Material requirements	15
13.3	Construction.....	15
13.3.1	<i>General</i>	15
13.3.2	<i>Bedding of drainage trough components</i>	15
13.3.3	<i>Assembling drainage trough components</i>	15
13.3.4	<i>Laying and jointing drainage trough components</i>	15
13.3.5	<i>Cutting drainage trough components</i>	16
13.3.6	<i>Installing holding down anchors</i>	16
14	Installation of precast pipe culvert components using jacking methods	16
14.1	General	16
14.2	Material requirements	16
14.3	Construction.....	16
15	Supply and installation of precast and preformed culvert and drainage trough components	17
15.1	General	17
15.2	Materials	17
15.3	Construction.....	17
16	Concrete end plugs for existing culverts	17
16.1	General	17
16.2	Construction.....	17
17	In situ concrete culvert components	17
17.1	General	17
17.2	Material requirements	17
17.3	Construction.....	17
17.3.1	<i>General</i>	17
17.3.2	<i>Special requirements for slab deck culverts</i>	18
17.3.3	<i>Special requirement for corrugated steel arch culverts</i>	18
18	End structures to culverts	18
18.1	General	18
18.2	Material requirements	18
18.3	Construction.....	18
19	Precast concrete end structures to culverts	19
19.1	General	19
19.2	Material requirements	19

19.3 Construction.....	19
20 Cast-in-place concrete kerb, channel, and kerb and channel.....	19
20.1 General	19
20.2 Material	20
20.3 Construction.....	20
20.4 Tolerances	20
20.5 Water test.....	20
21 Precast concrete kerb, channel, and kerb and channel blocks.....	21
21.1 General	21
21.2 Material	21
21.3 Construction.....	21
21.4 Tolerances	21
21.5 Water test.....	21
22 Shoulder dykes	21
22.1 General	21
22.2 Material requirements	22
22.3 Construction.....	22
22.3.1 General.....	22
22.3.2 Concrete shoulder dykes.....	22
22.4 Asphalt shoulder dykes.....	22
22.4.1 Precast concrete block shoulder dykes.....	22
22.5 Tolerances	22
23 Concrete gullies	23
23.1 General	23
23.2 Material requirements	23
23.3 Construction.....	23
23.4 Tolerances	24
23.4.1 Horizontal tolerances.....	24
23.4.2 Vertical tolerances.....	24
24 Insitu concrete access chambers	24
24.1 General	24
24.2 Materials requirements	24
24.3 Construction.....	24
24.4 Tolerances	25
24.4.1 Horizontal tolerances.....	25
24.4.2 Vertical tolerances.....	25
25 Precast concrete access chambers.....	25
25.1 General	25
25.2 Material requirements	25
25.3 Construction.....	26
25.4 Tolerances	27

26	Precast concrete side inlet gullies	27
26.1	General	27
26.2	Material requirements	27
26.3	Construction	27
26.3.1	General	27
26.3.2	Precast shafts	28
26.4	Tolerances	28
26.5	Water test	28
27	Subsoil drains	28
27.1	General	28
27.2	Materials requirements	28
27.2.1	Drainage pipes	28
27.2.2	Strip filter drains	29
27.2.3	Geotextiles	29
27.2.4	Trench backfill	29
27.2.5	Concrete	29
27.2.6	Marker posts	30
27.3	Storage of materials	30
27.4	Construction	30
28	Sheet or strip filter drains	31
28.1	General	31
28.2	Material requirements	31
28.3	Storage and handling of materials	32
28.4	Construction	32
29	Vertical drains	33
29.1	General	33
29.2	Material requirements	33
29.3	Construction	33
29.3.1	General	33
29.3.2	Special requirements for wick drains	33
29.3.3	Special requirements for sand drains	34
29.4	Tolerances	34
30	Stone columns	34
30.1	General	34
30.2	Construction procedure	34
30.3	Granular working platform	35
30.3.1	Materials	35
30.3.2	Construction	35
30.4	Stone columns	35
30.4.1	Materials	35
30.4.2	Construction	36
30.4.3	Tolerances	36
30.5	Construction of embankment	36
30.5.1	Materials	36
30.5.2	Construction	37

31	Concrete paved inverts in corrugated culverts	37
31.1	General	37
31.2	Material requirements	37
31.3	Construction	37
32	Linings in drains and channels	38
32.1	General	38
32.2	Material requirements	38
32.3	Construction	38
33	Berm drains	38
33.1	General	38
33.2	Materials	38
33.3	Construction	38
34	Concrete margins and batters	39
34.1	General	39
34.2	Material requirements	39
34.3	Construction	39
35	Concrete rail track crossings and machinery crossings	39
35.1	General	39
35.2	Material requirements	39
35.3	Construction	39
35.4	Tolerances	40
36	Hand-placed concrete paving.....	40
36.1	General	40
36.2	Material requirements	40
36.3	Construction	40
36.4	Colouring and finishing	41
36.5	Vertical tolerances	41
37	Sprayed concrete paving	41
37.1	General	41
37.2	Material requirements	41
37.3	Construction	41
37.4	Vertical tolerance	42
38	Block paving.....	42
38.1	General	42
38.2	Material requirements	42
38.3	Construction	43
	38.3.1 <i>Block laying</i>	43
	38.3.2 <i>Compaction</i>	43
	38.3.3 <i>Joint filling</i>	43
38.4	Vertical tolerance	44

39	Rock masonry	44
39.1	General	44
39.2	Material requirements	44
39.3	Construction.....	44
40	Grouted rock pitching	45
40.1	General	45
40.2	Material requirements	45
40.3	Construction.....	45
41	Rock protection.....	45
41.1	General	45
41.2	Material requirements	45
41.3	Construction.....	46
42	Steel-wire gabion protection	46
42.1	General	46
42.2	Material requirements	46
42.3	Basic gabion requirements	46
42.4	Construction.....	47
42.4.1	<i>Assembling, positioning and joining gabions</i>	47
42.4.2	<i>Forming shapes.....</i>	47
42.4.3	<i>Rock filling</i>	47
42.4.4	<i>Closing gabions</i>	47
43	Steel-wire mattress protection	47
43.1	General	47
43.2	Material requirements	47
43.2.1	<i>General.....</i>	47
43.2.2	<i>Proprietary mattresses</i>	48
43.2.3	<i>Non-proprietary mattresses.....</i>	48
43.3	Rock.....	48
43.4	Anchor pickets	48
43.5	Construction.....	48
43.5.1	<i>General.....</i>	48
43.5.2	<i>Installing anchors.....</i>	49
43.5.3	<i>Assembling, positioning and joining mattresses</i>	49
43.5.4	<i>Forming shapes.....</i>	49
43.5.5	<i>Tensioning of mattresses</i>	50
43.5.6	<i>Rock filling</i>	50
43.5.7	<i>Closing mattresses.....</i>	50
44	Fabric-encased concrete batter protection.....	50
44.1	General	50
44.2	Materials	50
44.2.1	<i>Fabric.....</i>	50
44.2.2	<i>Concrete</i>	51
44.3	Construction.....	51
44.3.1	<i>General.....</i>	51
44.3.2	<i>Placement of mats.....</i>	51

44.3.3	<i>Grouting</i>	51
45	Bridge abutment protection Type 1 – rock spillthrough	51
45.1	General	51
45.2	Material requirements	51
45.3	Construction.....	52
46	Bridge abutment protection Type 2 – reinforced concrete over earth spillthrough	52
46.1	General	52
46.2	Material requirements	52
46.3	Construction.....	52
46.4	Tolerances	53
47	Bridge abutment protection Type 4 – rockwork over earth spillthrough	53
47.1	General	53
47.2	Material requirements	54
47.3	Construction.....	54
48	Bridge abutment protection Type 6 – interlocking blockwork over earth spillthrough	54
48.1	General	54
48.2	Material requirements	54
48.3	Construction.....	55
48.4	Tolerances	56
49	Bridge abutment protection Type 7 – Rock-filled gabion protection	56
49.1	General	56
49.2	Material requirements	56
49.3	Construction requirements.....	56
50	Shotcreting	57
50.1	General	57
50.2	Material requirements	57
50.2.1	<i>Shotcrete</i>	57
50.2.2	<i>Steel reinforcing</i>	57
50.2.3	<i>Fixing pins</i>	58
50.3	Construction.....	58
50.4	Tolerances	59
51	Concrete retaining walls	59
51.1	General	59
51.2	Material requirements	59
51.3	Construction.....	59
51.4	Tolerances	60
52	Concrete masonry retaining walls	60
52.1	General	60
52.2	Material requirements	60
52.3	Construction.....	60

52.4 Tolerances	61
53 Crib walls	61
53.1 General	61
53.2 Material requirements	61
53.3 Construction	61
53.4 Tolerances	62
54 Boulder retaining walls	62
54.1 Boulder retaining walls	62
54.1.1 General	62
54.2 Material requirements	62
54.2.1 Rock fill	62
54.2.2 Drainage blanket	63
54.2.3 Packing stones in boulder walls	63
54.2.4 Foundation	63
54.3 Construction	63
54.3.1 Foundation construction requirements	63
54.3.2 Boulder wall placement	64
54.3.3 Backfill compaction	64
54.3.4 Concrete slurry fill	64
54.3.5 Seepage drains	64
54.3.6 Surface runoff behind the wall	65
54.4 Tolerances	65
55 Soil nailing	65
55.1 General	65
55.2 Methodology and construction procedure	65
55.3 Material requirements	65
55.3.1 Soil nails	65
55.3.2 Spacers	66
55.3.3 Cement grout	66
55.4 Construction	66
55.4.1 General	66
55.4.2 Drilling	66
55.4.3 Installation of soil nails	66
55.4.4 Grouting of soil nails	66
55.5 Acceptance testing of soil nails	67
56 Passive rock dowels	67
56.1 General	67
56.2 Methodology and construction procedure	67
56.3 Materials	68
56.3.1 Passive rock dowels	68
56.3.2 Spacers	68
56.3.3 Cement grout	68
56.4 Construction	68
56.4.1 General	68
56.4.2 Drilling	68
56.4.3 Installation of rock dowels	69
56.4.4 Grouting	69
56.5 Acceptance testing of passive rock dowels	69

57	Active rock bolts	70
57.1	General	70
57.2	Methodology and construction procedure	70
57.3	Materials	70
57.3.1	<i>Active rock bolts</i>	70
57.3.2	<i>Spacers</i>	70
57.3.3	<i>Cement grout</i>	71
57.4	Construction.....	71
57.4.1	<i>General</i>	71
57.4.2	<i>Drilling</i>	71
57.4.3	<i>Installation of rock bolts</i>	71
57.4.4	<i>Grouting</i>	71
57.5	Stressing active rock bolts	71
57.6	Load testing active rock bolt	72
58	Supplementary requirements	72
59	Surveying requirements	72
60	Existing underground assets	72

1 Introduction

This Technical Specification applies to the provision of drainage structures, retaining structures, and protective treatments in roadworks.

The requirements for reinforced soil retaining structures are specified in MRTS06 *Reinforced Soil Structures*.

This Technical Specification shall be read in conjunction with MRTS01 *Introduction to Technical Specifications*, MRTS50 *Specific Quality System Requirements* and other Technical Specifications as appropriate.

This Technical Specification forms part of the Transport and Main Roads Specifications Manual.

2 Definition of terms

The terms used in this Technical Specification shall be as defined in Clause 2 of MRTS01 *Introduction to Technical Specifications*. Additional terms used in this Technical Specification shall be as defined in Table 2.

Table 2 – Definition of terms

Term	Definition
Gabion	A steel-wire mesh cage which is filled with rock particles and used to construct a retaining structure.
Mattress	A steel-wire mesh cage which is filled with rock particles and used to line a drainage channel.
Spillthrough	That portion of an embankment constructed adjacent to and under a bridge abutment.

End structures for culverts are defined by the terms detailed in Figure 2.

Figure 2 – Culvert end structure terms

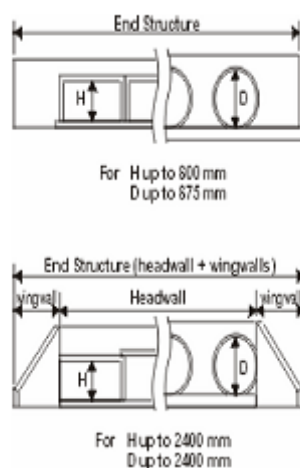

3 References

Tables 3(a) and 3(b), below, list documents referenced in this Technical Specification.

Table 3(a) – Referenced documents

Reference	Title
AS 1379	<i>Specification and supply of concrete</i>
AS 1762	<i>Helical lock-seam corrugated steel pipes – Design and Documentation</i>
AS 1830	<i>Grey cast iron</i>
AS 2338	<i>Preferred dimensions of wrought metal products</i>
AS 2423	<i>Coated steel-wire fencing products for terrestrial, aquatic and general use</i>
AS 2439.1	<i>Perforated plastics drainage and effluent pipe and fittings – Perforated drainage pipe and associated fittings</i>
AS 3678	<i>Structural steel – hot-rolled plates, floor plates and slabs</i>
AS 3679.1	<i>Structural steel – hot-rolled bars and sections</i>
AS 3600	<i>Concrete structures</i>
AS 3700	<i>Masonry structures</i>
AS 3750.9	<i>Paints for steel structures – Organic zinc – rich primer</i>
AS 3996	<i>Access covers and grates</i>
AS 5100	<i>Bridge design – scope and general principles</i>
AS/NZS 1254:2010	<i>PVC-U pipes and fittings for stormwater and surface water applications</i>
AS/NZS 2041.4:2010	<i>Buried corrugated metal structures – Helically formed sinusoidal pipes</i>
AS/NZS 2041:1998	<i>Buried corrugated metal structures</i>
AS/NZS 4455.1	<i>Masonry units, pavers, flags and segmental retaining wall units – Masonry units</i>
AS/NZS 4671	<i>Steel reinforcing materials</i>
AS/NZS 4680	<i>Hot-dipped galvanised (zinc) coatings on fabricated ferrous articles</i>
MRTS01	<i>Introduction to Technical Specifications</i>
MRTS04	<i>General Earthworks</i>
MRTS05	<i>Unbound Pavements</i>
MRTS06	<i>Reinforced Soil Structures</i>
MRTS24	<i>Manufacture of Precast Concrete Culverts</i>
MRTS25	<i>Manufacture of Precast Concrete Pipes</i>
MRTS26	<i>Manufacture of Fibre Reinforced Concrete Drainage Pipes</i>
MRTS27	<i>Geotextiles (Separation and Filtration)</i>
MRTS30	<i>Asphalt Pavements</i>
MRTS50	<i>Specific Quality System Requirements</i>
MRTS70	<i>Concrete</i>

Reference	Title
MRTS71	<i>Reinforcing Steel</i>
MRTS72	<i>Manufacture of Precast Concrete Elements</i>
MRTS77	<i>Bridge Deck</i>
MRTS78	<i>Fabrication of Structural Steelwork</i>
-	<i>TMR Surveying Standards</i>

Table 3(b) – Referenced departmental Standard Drawings

Standard Drawing Number	Title
1033	<i>Kerb and channel — Kerbs, channels and ramped vehicular crossing</i>
1116	<i>Subsoil drains - Outlets and cleanouts</i>
1174	<i>R C Box Culverts – Installation of Precast Units and Construction Headwalls – Height = 375 to 600</i>
1303	<i>R C Box Culverts & Slab Link Box Culverts - Construction of Headwalls and Wingwalls – Height > 600</i>
1304	<i>Pipe Culverts – Wingwalls, Headwall and Apron for Pipe Diameter 750 to 2400 – Drawing 1 of 2 to 2 of 2</i>
1305	<i>Pipe Culverts - Headwall and Apron for Pipe Diameter 375 to 675</i>
1307	<i>Access Chamber - Details 1050 to 2100 Dia.</i>
1308	<i>Access Chamber - Roof Slabs 1050 to 2100 Dia.</i>
1313	<i>Concrete Gully - Precast Lintel Details</i>
1316	<i>R C Box Culverts & Slab Link Box Culverts - Installation of Precast Units – Height > 600</i>
1317	<i>R C Box Culverts & Slab Link Box Culverts - Construction of Bases with Nibs and Aprons (all sizes)</i>
1318	<i>R C Box Culverts & Slab Link Box Culverts - Construction of Bases with Recesses and Aprons (all sizes)</i>
1320	<i>R C Box Culverts & Slab Link Box Culverts - Crown Unit Holding Down Anchors</i>
1321	<i>Concrete Gully - Precast Concrete Side Inlet Gully with Precast Shaft</i>
1322	<i>Concrete Gully - Precast Concrete Side Inlet Gully with Cast In Situ Pit</i>
1443	<i>Concrete Gully - Roadway Type Precast Inlet Units on Grade</i>
1444	<i>Concrete Gully - Roadway Type Precast Inlet Units in Sag</i>
2232	<i>Abutment Protection – Type 1 - Rock Spillthrough - Up to 1700 Clearance</i>
2233	<i>Abutment Protection – Type 1 - Rock Spillthrough – Greater Than 1700 Clearance</i>
2234	<i>Abutment Protection – Type 2 - Reinforced Concrete Over Spillthrough - Up to 1700 Clearance</i>
2235	<i>Abutment Protection – Type 2 - Reinforced Concrete Over Spillthrough - Greater Than 1700 Clearance</i>

Standard Drawing Number	Title
2236	<i>Abutment Protection – Type 4 - Rockwork Over Spillthrough - Up to 1700 Clearance</i>
2237	<i>Abutment Protection – Type 4 - Rockwork Over Spillthrough - Greater Than 1700 Clearance</i>
2238	<i>Abutment Protection - Rock Masonry</i>
2241	<i>Abutment Protection – Type 7 - Rock Filled Gabion Protection – Height up to 6 Metres</i>

4 Standard test methods

The Standard test methods listed in Table 4 shall be used in this Technical Specification.

Table 4 – Standard Test Methods

Property to be tested	Method No.
Particle size distribution	AS 1141.11.1
Density index	AS 1289.5.5.1 AS 1289.5.6.1
Los Angeles value	AS 1141.23
Particle density on a dry basis	AS 1141.6.1
Apparent particle density	AS 1141.6.1
Point load strength index	AS 4133.4.1
Total weighted loss	AS 1141.24
Water absorption	AS 1141.6.1
California Bearing Ratio (CBR)	Q113C
Compressive strength	AS 1012.8.3 AS 1012.9
Tensile strength – warp and weft	ASTM D5034 and D5035
Porosity	ASTM D737

Further details of test numbers and test descriptions are given in Clause 4 of MRTS01 *Introduction to Technical Specifications*.

5 Quality system requirements

5.1 Hold Points, Witness Points and Milestones

General requirements for Hold Points, Witness Points and Milestones are specified in Clause 5.2 of MRTS01 *Introduction to Technical Specifications*.

The Hold Points, Witness Points and Milestones applicable to this Technical Specification are summarised in Table 5.1.

Table 5.1 – Hold Points, Witness Points and Milestones

Clause	Hold Point	Witness Point	Milestone
12.2	1. Bandage cover materials for culvert joints		
12.3.1	2. Approval of Culvert Construction Procedure		
12.3.5	3. Acceptance of CCTV Defect Inspection Report		
12.3.10	4. Backfilling of culverts		
20.5		1. Water flow test in concrete channels	
21.5		2. Water flow test in precast block channels	
23.3	5. Grate placement		
24.3	6. Concrete top slab placement		
25.3	7. Concrete top slab placement		
26.5		3. Water flow test in precast concrete side inlet gullies	
27.4		4. Flushing of sub-soil drains	
29.3.1			Sequence for construction of vertical drains (14 days)
30.2	8. Construction of stone columns		Submission of construction for stone columns (28 days)
44.3.2	9. Grouting of fabric-encased batter protection		
48.2	10. Use of alternative interlocking blocks		Submission of technical details of interlocking blocks (14 days)
49.3	11. Submission of method statement		
51.3	12. Backfilling on concrete retaining wall footing		
55.2	13. Installation of soil nails		Submission of construction procedure for soil nails (14 days)
55.4.4.2	14. Grouting of soil nails		
55.5	15. Acceptance of soil nails		
56.2	16. Installation of passive rock dowels		Submission of construction procedure for passive rock dowels (14 days)

Clause	Hold Point	Witness Point	Milestone
56.4.4.2	17. Grouting of passive rock dowels		
56.5	18. Acceptance of passive rock dowels		
57.2	19. Installation of active rock bolts		Submission of construction procedure for active rock bolts (14 days)
57.4.4.2	20. Grouting of active bolts		
57.6	21. Acceptance of active rock bolts		

5.2 Construction procedures

The Contractor shall prepare documented procedures for all construction processes in accordance with Clause 5 of MRTS50 *Specific Quality System Requirements*.

Those construction procedures which are required to be submitted by the Contractor to the Administrator in accordance with Clause 5 of MRTS50 *Specific Quality System Requirements* include those listed in Table 5.2.

Table 5.2 – Construction procedures

Clause	Procedure
12.3.1	Culvert construction
30.2	Stone columns
55.4.3	Installation of soil nails
56.4.3	Installation of rock dowels
57.4.3	Installation of rock bolts

5.3 Compliance testing

Compliance testing shall be carried out for each lot.

The Contractor shall undertake sufficient tests to ensure that the works comply with the Technical Specifications and requirements of the Contract.

The testing program shall be such that the testing frequencies and number of tests are not less than those required by Clause 5.4.

5.4 Testing frequency

The minimum test frequencies and minimum numbers of tests as stated in Clause 1 of Annexure MRTS03.1 shall apply to the construction of work covered by this Technical Specification.

6 General material and construction requirements

6.1 Concrete and reinforcing steel

Concrete and reinforcing steel shall be in accordance with the requirements of MRTS70 *Concrete* and MRTS71 *Reinforcing Steel* respectively, and with the following requirements:

- a) The minimum characteristic strength of concrete shall be as specified within the drawings.
- b) Construction joints shall be provided only as specified within the drawings and no construction joint specified within the drawings shall be omitted.
- c) Weepholes shall be provided at the locations specified within the drawings and to the details specified. A 300 mm x 300 mm x 150 mm thick 'no-fines' concrete block wrapped with a non-woven geotextile complying with MRTS27 *Geotextiles (Separation and Filtration)* shall be provided and placed or constructed at each weephole.
- d) Where concrete is constructed on ground surfaces or on a foundation bedding, a polythene sheet separator of thickness not less than 100 µm shall be installed between the ground/bedding and the concrete. The separator shall extend not less than 300 mm beyond the concrete. Puncturing or tearing the separator shall be avoided. Should puncturing or tearing occur, the damage shall be repaired prior to concreting. Joints in the separator shall be provided by overlapping the sheets a minimum of 300 mm or by overlapping and taping.
- e) Rock plums may be employed in unreinforced concrete. Individual plums shall not exceed 150 mm dimension. Plums shall not constitute more than 30% of the volume of concrete, and
- f) Concrete shall be cured for the period of time specified for the application and the concrete mix used or, where such time is not specified, for a minimum of seven days.

6.2 Cement mortar

Unless otherwise specified, cement mortar shall consist of one part of Type GP cement to three parts of clean sharp sand, with only sufficient water added to form a moist dry-pack material. Materials shall comply with MRTS70 *Concrete*.

6.3 Cement grout

Cement grout shall consist of neat cement or neat cement with a plasticised expanding grout admixture (e.g., a methyl-cellulose-based compound used at a rate of 0.2% by weight of cement). Mixing of the admixture with cement shall be in accordance with the manufacturer's recommendations. Cement shall be either Type GP or Type HE in accordance with MRTS70 *Concrete*.

The water-cement ratio of the grout shall not be greater than 0.4.

Where required, the compressive strength of the grout shall be determined using samples cast in 50 mm cube moulds in accordance with AS 1012.8.3 and tested in accordance with AS 1012.9.

6.4 Grates, cover and frames

Grates, cover and frames for gullies and access chambers shall:

- a) meet Class D requirements when tested in accordance with AS 3996, and
- b) have a positive mechanical retainer system to stop accidental closure of the grate or cover when in the open position in accordance with the requirements of AS 3996.

Grates located on a road carriageway or bicycle path shall meet bicycle safety requirements in accordance with AS 3996.

6.5 Excavation and backfilling

Excavation and backfilling operations required to be undertaken to construct the work described by this Technical Specification shall be carried out in accordance with the provisions of MRTS04 *General Earthworks*.

6.6 Proprietary products

Where proprietary products are specified within this Technical Specification, the Contractor shall guarantee and, if requested, submit evidence that the product used shall be satisfactory, structurally adequate, durable and safe for the intended purpose, and also complies with the law and applicable Australian Standards.

In particular, any structural (or load bearing) component/product shall be designed to accommodate all temporary and permanent loadings, and the component/product shall be constructed in accordance with that design, certified by a practising Structural Engineer.

A full set of auditable design calculations shall be made available for perusal if requested by the Administrator.

Precast concrete proprietary products shall be cast in accordance with MRTS72 *Manufacture of Precast Concrete Elements* by a registered precaster.

7 Geometric tolerances for culverts

7.1 General

The horizontal and vertical alignments of culverts shall not exhibit noticeable irregularities.

Culverts shall have a positive drainage slope along the whole of their length and, where relevant, shall join neatly to existing structures.

7.2 Horizontal tolerances

The horizontal alignment of culverts shall not vary from the location specified in the drawings by more than ± 100 mm.

7.3 Vertical tolerances

The invert heights of culverts shall not vary from those specified by more than ± 10 mm, provided always that nowhere shall the grades of culverts depart from those specified by more than 1% (absolute).

Notwithstanding these tolerances, the minimum thickness of cover over culverts shall nowhere be less than as shown on the drawings. If cover is not shown or if it is not clear, it shall be nowhere less than the following:

- a) 100 mm for concrete box culverts, and cast-in-place concrete slab deck culverts and concrete unitary box culverts if deck wearing surfaces are not specified
- b) 300 mm for concrete pipe culverts, and

- c) 600 mm or diameter or span

6

whichever is the greater for corrugated steel culverts.

8 Removal or demolition of culverts and culvert end structures

8.1 General

Clause 8 applies to the work to be carried out where culverts and culverts end structures are to be removed or demolished under the Contract.

8.2 Description

Culverts and culvert end structures shall be removed or demolished where specified in the drawings. If existing culvert components are to be removed and re-used, they shall be removed and stacked in a manner which avoids damaging the components. Removed components which are not to be salvaged, nor reused, shall be removed from the Site and disposed.

The culvert components listed in Clause 2.1 of Annexure MRTS03.1 are required to be salvaged intact by the Contractor and delivered and stored at the storage site nominated in Clause 2.2 of Annexure MRTS03.1.

Excavations carried out and the void left by the removed culvert or end structure shall be backfilled to reinstate the area to a safe and free draining state.

9 Removal / demolition of kerbs and channels and concrete slabs

9.1 General

Clause 9 applies to the work to be carried out where kerbs and channels and concrete slabs are to be removed or demolished under the Contract.

9.2 Description

Existing kerbs, channels, kerbs and channels, kerb crossings and concrete slabs shall be removed or demolished where specified in the drawings.

No damage shall result to adjacent work.

Where part only of existing kerbs, channels, kerbs and channels, kerb crossings and slabs are to be removed or demolished and new kerbs, channels, kerbs and channels, kerb crossings and slabs are to be joined to the remaining part, removal or demolition operations shall terminate at a joint.

Alternatively, the existing kerb, channel, kerb and channel, kerb crossing or slab shall be sawn to provide a clean joint.

Any resulting excavations shall be backfilled and the surface finished level with the surrounding area.

10 Removal / demolition of gullies and access chambers

10.1 General

Clause 10 applies to the work to be carried out where gullies and access chambers are to be removed or demolished under the Contract.

10.2 Description

Gullies and access chambers shall be removed or demolished where specified in the drawings.

Gullies and access chambers shall be removed or demolished in a manner which avoids damaging any adjacent work.

Resulting excavations and voids shall be backfilled and the surface finished level with the surrounding area.

11 Supply of precast and preformed culvert and drainage trough components

11.1 General

Clause 11 applies to the work to be carried out where precast and preformed culvert and drainage trough components are required to be supplied under the Contract.

Precast and preformed culvert components shall comprise precast pipes, preformed pipes, unitary box units, U-shaped units, lid, base and spanning slabs, plates, couplers, rubber rings, arch channels, bolts, nuts, washers, plugs, dowels and all other fittings necessary for the installation of the components to be provided.

11.2 Material requirements

Precast and preformed culvert components shall conform to the following requirements:

- a) Concrete pipe culvert components shall comply with the requirements specified in MRTS25 *Manufacture of Precast Concrete Pipes* or with MRTS26 *Manufacture of Fibre Reinforced Concrete Drainage Pipes*:
 - i. All pipes supplied to MRTS25 of diameter 800 mm or less shall have joints which are spigot and socket with rubber sealing rings. Joints for other sizes shall be as specified on the drawings.
 - ii. All pipes supplied to MRTS26 shall have flexible elastomeric double 'V' ring joints.
- b) Concrete box culvert components and spanning slabs shall comply with MRTS24 *Manufacture of Precast Concrete Culverts*.
- c) Helical lock-seam corrugated steel pipe culvert components shall:
 - i. comply with the requirements specified in AS/NZS 2041.4
 - ii. comply with the requirements of AS 1762, except that Tables A1, A2, A3 and A4 shall be deleted and AS 1762 Appendix C shall be replaced by Table 11.2, and
 - iii. have an allowance for corrosion of 1 mm.

Table 11.2 – Live load pressure for AS 5100 highway loads

Depth (m)	Wheel Load Pressure (kPa)	Depth (m)	Wheel Load Pressure (kPa)
0.40	246	2.80	19
0.60	129	3.00	18
0.80	78	3.20	17
1.00	52	3.40	17

Depth (m)	Wheel Load Pressure (kPa)	Depth (m)	Wheel Load Pressure (kPa)
1.20	39	3.60	16
1.40	30	3.80	16
1.60	24	4.00	15
1.80	23	4.20	15
2.00	22	4.40	14
2.20	21	4.60	14
2.40	20	4.80	13
2.60	19	5.00	13

- d) Nestable corrugated steel pipe culvert components and multiple plate corrugated steel pipe or pipe-arch or arch culvert components shall:
- i. comply with the requirements specified in AS/NZS 2041, except that Appendix E shall be deleted and AS/NZS 2041 Appendix G shall be replaced by Table 11.2, and
 - ii. have an allowance for corrosion of 1 mm.
- e) Helical lock-seam corrugated aluminium pipe culvert components shall comply with the requirements stated in Clause 3.1 of Annexure MRTS03.1 or, where not so stated, shall be subject to prior approval by the Administrator.

The culvert component size, class and/or wall thickness shall be as specified in the drawings.

The design height of fill above box culverts shall be as specified in the drawings or in Clause 3.2 of Annexure MRTS03.1.

12 Installation of precast and preformed culvert components

12.1 General

Clause 12 applies to the work to be carried out where precast and preformed culvert components are required to be installed under the Contract.

12.2 Material requirements

Bandage covers shall be a suitable proprietary product consisting of:

- a) a synthetic woven or non-woven fabric factory impregnated with a rubberised bitumen or a neutral petrolatum based compound, or
- b) plastic or natural rubber bands.

Woven or non-woven fabrics shall have the following properties:

- a) grab tensile strength not less than 300 N (50 mm wide strip)
- b) thickness not less than 1.25 mm, and
- c) mass not less than 1.4 kg/m².

Plastic and natural rubber bands shall have properties appropriate to the sealing requirements and shall be to the approval of the manufacturer of the culvert components concerned.

Samples of the materials to be used as bandage covers shall be made available for inspection by the Administrator prior to commencement of installation. **Hold Point 1**

Concrete in end blocks shall comply with Clause 6.1, except that the maximum aggregate size shall not exceed 9.5 mm.

Concrete infill material shall consist of one part of Type GP cement to 10 parts aggregate (loose volume). The maximum aggregate size shall be 9.5 mm.

Lean Mix concrete shall have one part of Type GP cement to 10 parts aggregate, loose volume.

Holding down anchors shall comply with the details shown on the Standard Drawings.

12.3 Construction

12.3.1 General

Prior to construction, the construction loads which shall be placed on the culvert by the proposed construction procedure and equipment shall be checked. If the culvert is to be installed prior to the age at which the nominal concrete strength is achieved, the check shall account for the actual strength of the concrete at the time of construction. If necessary, a culvert with a higher class of concrete shall be substituted. Construction of culverts shall not commence until the check of the construction procedure has been carried out. For concrete pipe culverts, refer to Clause 12.3.5 for additional requirements for constructions loads. **Hold Point 2**

Precast and / or preformed culvert components shall be installed in the locations and in accordance with the details shown in the drawings.

The drainage structure shall be set out in accordance with the details shown in the drawings. The provisions of Clause 9 of MRTS01 *Introduction to Technical Specifications* apply to the set out procedure.

Excavations shall be carried out in accordance with Clause 13 of MRTS04 *General Earthworks*.

Concrete shall comply with the requirements specified in Clause 6.1. Where corrugated steel culvert components are installed, the invert heights specified are the levels of the tops of the corrugations.

All drainage structures shall be marked with indelible ink on the inside face with the name of the Manufacturer and month and year of manufacture.

12.3.2 Bedding of culvert components

Foundation bedding and haunch zone materials shall be placed in accordance with Clause 19 of MRTS04 *General Earthworks*.

The foundation bedding shall provide continuous, even support to the culvert components.

12.3.3 Assembling culvert components

Culvert components shall be assembled in accordance with the manufacturer's drawings and recommendations as relevant.

Where corrugated steel pipe culvert components are employed, circumferential joints shall be staggered and longitudinal joints shall be horizontally opposed.

Where multiple plate corrugated steel arch culvert components are employed, the arch channels shall be filled with cement mortar after the arch has been assembled. The top surface of the mortar filling shall be sloped such that water shall not pond in the arch channel or against the arch.

12.3.4 Laying and jointing culvert components

Where possible, laying of culvert components shall commence at the outlet end of the culvert and progress to the inlet end.

Components shall be selected and arranged to give best fit.

The ends of components shall be free of any foreign matter at the time of jointing.

In butt and flush joints, the culvert components shall abut one another and a bandage cover shall be installed on the outer surfaces to seal the joints.

Unless a specific type of bandage cover is specified in the drawings, the bandage cover shall consist of:

- a) one layer of non-woven fabric
- b) three layers of woven fabric, or
- c) a plastic or natural rubber band.

Fabric covers shall have a width sufficient to overlap adjacent components by not less than 45 mm, and shall not be applied until the ambient temperature exceeds 15°C. Fabric covers shall not be wrinkled and shall adhere to the outer surfaces of the adjacent components. The ends of the fabric in the covers shall be secured in accordance with the manufacturer's recommendations.

Plastic or natural rubber covers shall be installed in accordance with the manufacturer's recommendations.

Bandage covers are not required for legs of adjacent culverts in multiple installations where the joint is infilled with concrete.

12.3.5 Special requirements for concrete pipe culvert components

Construction and installation loading shall comply with the requirements specified in MRTS25 *Manufacture of Precast Concrete Pipes* or MRTS26 *Manufacture of Fibre Reinforced Concrete Drainage Pipes* and associated annexures as appropriate.

Where spigot and socket joints are used, the thickness of bedding material under each socket shall not be less than 50 mm.

Pipes shall be placed with their external grooved ends or spigot ends facing the culvert outlet.

Where the word 'TOP' is marked on pipes or where lifting holes are provided, the pipes shall be laid with the word / hole uppermost. Lifting holes shall be plugged or otherwise closed off in accordance with the manufacturer's instructions after the pipe is installed.

Spigot and socket joints shall be made using the appropriate rubber rings.

At the completion of the pipe installation, including placement and compaction of fill to the final specified fill height, the contractor shall undertake a CCTV defect inspection with WNCAN report to demonstrate that the completed pipe installation is acceptable to the department and that the pipes are correctly installed and are free of Defect Types 2,3,5, 6 and 7 as defined in MRTS25 *Manufacture of Precast Concrete Pipes* for Steel Reinforced Concrete Pipes and free of cracks and joint damage for Fibre Reinforced Concrete Drainage Pipes. Acceptance of this report by the Administrator shall be a **Hold Point 3**

12.3.6 Special requirements for concrete box culvert components

Box culvert components shall generally be installed in accordance with the details shown on Standard Drawing 1316.

U-shaped units supplied with precast lid/base slabs shall be installed as follows:

- a) units laid in the 'legs up' position shall be placed directly on a foundation bedding. The lid slabs shall be seated onto the tops of the legs using continuous cement mortar pads, and
- b) units laid in the 'legs down' position on base slabs shall be seated onto the slabs using continuous cement mortar pads. The base slabs shall be placed directly on a foundation bedding.

U-shaped units laid in the 'legs down' position on cast-in-place concrete bases shall be seated on to the bases using continuous cement mortar pads. Where specified, holding down anchors shall also be installed to retain the units in position in accordance with the details shown on Standard Drawing 1320.

Corrodible lifting lugs shall be cut off close to the unit. The exposed ends of the embedded portions of the lug shall be given two coats of a surface tolerant epoxy.

Where spanning slabs are installed, locating dowels shall be installed in the tops of the units and the spanning slabs shall be seated on continuous cement mortar pads on adjacent unit — all as shown on the Standard Drawing. All surplus mortar shall be removed from the installation before the mortar hardens.

In multiple cell culverts, the gaps between lines of installed cells shall be a minimum of 40 mm wide and filled as follows:

- a) Concrete end blocks extending not less than 250 mm along the gap shall be constructed to full height at each end of the culvert. Headwall anchor bars shall be installed in the end blocks as specified in the Standard Drawings, and
- b) After the end blocks have hardened, the remaining gaps between the cells shall be dry packed with concrete infill material.

Where spanning slabs are installed, the space between slabs shall be filled with lean mix concrete. No other backfilling material shall be placed over the culvert for 24 hours after the placement of the lean mix concrete.

12.3.7 Special requirements for corrugated steel culvert components

Thrust beams and ring beams shall be constructed in accordance with the manufacturer's drawings and recommendations as relevant.

12.3.8 Special requirements for corrugated pipe, pipe-arch and arch culverts

The deformation limits specified in MRTS04 *General Earthworks* shall be strictly adhered to during installation and backfilling operations.

12.3.9 Cutting culvert components

Cutting operations shall provide neat end surfaces.

The cut surfaces of reinforced concrete culvert components shall be given two coats of a surface tolerant epoxy.

The cut surfaces of steel culvert components shall be given two coats of zinc-rich organic priming paint as specified in AS 3750.9. The coats shall have a combined thickness at least equivalent to the thickness of the galvanised coating. Each coat shall overlap the adjacent uncut surfaces by not less than 25 mm.

12.3.10 Backfilling of culverts

Backfilling of culverts shall be carried out in accordance with clauses 15 and 20 of MRTS04 *General Earthworks*.

Backfilling of culverts shall not commence until all the conformance and As Constructed Survey requirements have been met and notice of such works provided to the Administrator. **Hold Point 4**

13 Installation of precast and preformed drainage trough components

13.1 General

Clause 13 applies to the installation of precast and preformed drainage trough components.

13.2 Material requirements

Bandage covers shall be a synthetic woven or non-woven fabric as specified in Clause 12.2.

13.3 Construction

13.3.1 General

Precast and/or preformed culvert components shall be installed in the locations and in accordance with the details specified in the drawings.

Excavations shall be carried out in accordance with Clause 13 of MRTS04 *General Earthworks*.

Where corrugated steel drainage trough components are installed, the invert heights specified are the levels of the tops of the corrugations.

All drainage structures shall be marked with indelible ink on the inside face with the name of the Manufacturer and month and year of manufacture.

13.3.2 Bedding of drainage trough components

Foundation bedding materials shall be placed in accordance with Clause 19 of MRTS04 *General Earthworks*.

The foundation bedding shall provide continuous, even support to the drainage trough components.

13.3.3 Assembling drainage trough components

Drainage trough components shall be assembled in accordance with the manufacturer's drawings and recommendations.

13.3.4 Laying and jointing drainage trough components

Drainage trough components shall be laid with the tops flush with the finished batter.

Laying of drainage trough components shall commence at the outlet end of the trough and progress to the inlet end. Where necessary, components shall be selected and arranged to give satisfactory fit.

The ends of components shall be free of any foreign matter at the time of jointing. When butt and flush joints are specified, the drainage trough components shall abut one another.

Bandage covers shall be applied to the outer surfaces of butt and flush joints. Bandage covers shall consist of:

- a) one layer of non-woven fabric, or
- b) three layers of woven fabric.

Fabric covers shall have a width sufficient to overlap adjacent components by not less than 45 mm and shall not be applied until the ambient temperature exceeds 15°C. Fabric covers shall not be wrinkled and shall adhere to the outer surfaces of the adjacent components. The ends of the fabric in the covers shall be secured in accordance with the manufacturer's recommendations.

13.3.5 Cutting drainage trough components

Cutting operations shall provide neat end surfaces.

The cut surfaces of concrete drainage trough components shall be given two coats of a surface tolerant epoxy.

The cut surfaces of corrugated steel drainage trough components shall be given two coats of zinc-rich organic priming paint as specified in AS 3750.9. The coats shall have a combined thickness at least equivalent to the galvanised coating thickness. Each coat shall overlap adjacent uncut surfaces by not less than 25 mm.

13.3.6 Installing holding down anchors

Holding down anchors shall be installed in accordance with the requirements specified in the Standard Drawings and the manufacturer's recommendations as relevant.

14 Installation of precast pipe culvert components using jacking methods

14.1 General

Clause 14 applies to the installation of precast pipe culvert components using jacking methods.

14.2 Material requirements

Concrete pipes installed using jacking methods shall be Class 4 with suitable joints designed by the manufacturer.

Cement mortar shall comply with Clause 6.2.

14.3 Construction

Pipe jacking shall be carried out in the locations specified by, and in accordance with, the drawings.

Pipe jacking shall be carried out only by experienced personnel.

Jacking operations shall comply with the pipe manufacturer's recommendations.

Jacking operations shall proceed with care so as to cause no damage to the pipes.

The location of any existing underground services shall be established prior to commencement of jacking operations and all reasonable care shall be taken not to damage such services or any adjacent work.

Pipe joints shall be sealed with cement mortar after installation of the pipes.

All drainage structures shall be marked with indelible ink on the inside face, with the name of the Manufacturer and month and year of manufacture.

15 Supply and installation of precast and preformed culvert and drainage trough components

15.1 General

Clause 15 applies to the work to be carried out where precast and preformed culvert and drainage trough components are required to be supplied and installed under the Contract.

15.2 Materials

Materials shall conform to the relevant requirements of Clauses 11.2, 12.2, 13.2 and 14.2 as appropriate.

Where one type of pipe is detailed on the drawings and the Contractor proposes to use an alternative, the Contractor shall ensure that all details are amended to be compatible and that as-constructed drawings are prepared and submitted to the Administrator.

15.3 Construction

Construction shall conform to the relevant requirements of Clauses 12.3, 13.3 and 14.3, as appropriate.

16 Concrete end plugs for existing culverts

16.1 General

Clause 16 applies to the provision of concrete end plugs for existing culverts.

16.2 Construction

Concrete end plugs shall be used to seal off existing culverts that are to be taken out of service, but not removed or demolished.

Concrete end plugs for culverts shall be constructed in the locations and in accordance with the details shown on the drawings.

Concrete shall comply with Clause 6.1.

The thickness of the plugs shall be not less than 500 mm. The plugs shall completely seal the ends of the culverts.

17 Insitu concrete culvert components

17.1 General

Clause 17 applies to construction of situ concrete culvert components.

17.2 Material requirements

Concrete shall comply with Clause 6.1.

Galvanised arch channels with integral arches shall be approved proprietary products.

17.3 Construction

17.3.1 General

Cast-in-place culvert components shall be constructed in the locations specified by, and in accordance with, the drawings. If not specifically detailed in the drawings, box culvert bases shall be constructed in accordance with the details shown on Standard Drawings 1317 and 1318.

Where insitu material on or against which culvert bases or footings are to be constructed is other than rock, the material shall be compacted as for material at the bottom of excavations in accordance with MRTS04 *General Earthworks*.

Cast-in-place concrete bases, footings, infill floors, abutments, piers and unitary box culverts may be constructed without a foundation bedding unless specified otherwise in the drawings.

Concrete work shall comply with Clause 6.1.

Construction of bases, footings, infill floors, abutments and piers, and unitary box culverts shall include the construction of nibs and integral cut-off walls.

17.3.2 Special requirements for slab deck culverts

Construction of bases and footings shall include the provision and installation of embedded dowel bars for abutments and piers. Construction of abutments and piers shall include the provision and installation of embedded dowel bars for slab decks and kerbs. Slab decks and kerbs shall be constructed monolithically.

17.3.3 Special requirement for corrugated steel arch culverts

Construction of abutments and piers shall include the supply and installation of galvanised arch channels (with integral anchorages).

18 End structures to culverts

18.1 General

Clause 18 applies to end structures to culverts.

18.2 Material requirements

Concrete shall comply with Clause 6.1.

Steel Reinforcement shall comply with MRTS71 *Reinforcing Steel*.

Material for rock masonry shall comply with Clause 39.

Materials for concrete masonry shall comply with Clause 51.

Materials for grouted rock pitching shall comply with Clause 40.

Materials for steel-wire mattresses shall comply with Clause 43.

18.3 Construction

Cast, formed-in-place endwalls and wingwalls, aprons, and kerbs to culverts shall be provided in the locations specified in the drawings. Unless otherwise specified in the drawings, cast-in-place concrete end structures to culverts shall comply with the details shown on Standard Drawings 1174, 1303, 1304, 1305, 1317, 1318 and 1319 as applicable.

Where insitu material on or against which structures are to be constructed is other than rock, the material shall be compacted as for material at the bottom of excavations in accordance with MRTS04 *General Earthworks*.

Concrete shall be constructed to comply with Clause 6.1.

The construction of rock masonry shall comply with Clause 39.

The construction of concrete masonry shall comply with Clause 51.

The construction of grouted rock pitching shall comply with Clause 40.

The construction of steel-wire mattresses shall comply with Clause 43.

Endwalls, wingwalls and concrete aprons may be constructed without a foundation bedding.

Endwalls and wingwalls shall be formed monolithically.

Construction of endwalls and wingwalls shall include the construction of integral cutoff walls where relevant.

Construction of aprons shall include the construction of integral cut-off walls, the construction of integral energy dissipaters if specified and the installation of dowel bars.

Rock masonry endwalls and wingwalls shall be capped with a cement mortar coping not less than 25 mm thick. The coping shall be trowelled to provide smooth, even surfaces with neat edges.

19 Precast concrete end structures to culverts

19.1 General

Clause 19 applies to the provision of precast concrete end structures for culverts.

19.2 Material requirements

Precast concrete end structures shall be proprietary products manufactured in accordance with Clause 6.6.

Cement mortar shall comply with Clause 6.2.

19.3 Construction

Precast concrete end structures to culverts shall be installed in the locations and in accordance with the drawings.

Where insitu material on or against which end structures are to be constructed is other than rock, the material shall be compacted as for material at the bottom of excavations in accordance with MRTS04 *General Earthworks*.

End structures shall be laid on a foundation bedding which provides continuous even support to the structures.

The joints between end structures and culverts shall be filled with cement mortar. The joint areas shall be thoroughly cleaned and wetted just prior to filling. All joints shall be finished smooth and uniform with the surfaces of the end structures.

Any holes and recesses provided in end structures to assist installation shall be neatly plugged or filled with cement mortar.

Mortared joints and filled holes and recesses shall be cured for a period of not less than 48 hours. Backfilling operations against end structures shall not be carried out during the curing period.

20 Cast-in-place concrete kerb, channel, and kerb and channel

20.1 General

Clause 20 applies to the provision of cast-in-place concrete kerb, channel and kerb and channel. The Clause does not apply to kerbs cast integrally with structures.

20.2 Material

Concrete shall comply with Clause 6.1.

Compressible packing shall be bitumen impregnated fibre board or other suitable packing.

20.3 Construction

Cast-in-place concrete kerb, channel, and kerb and channel, including kerb crossings, shall be provided in the locations specified in the drawings and in accordance with Standard Drawing 1033.

Where insitu material on or against which kerbs or channels are to be constructed is other than rock, the material shall be compacted as for material at the bottom of excavations in accordance with MRTS04 *General Earthworks*. The ground surface shall be moistened just prior to placing concrete.

Manually-placed concrete shall be in accordance with Clause 6.1. Exposed surfaces shall have a steel-trowelled finish.

Where kerb, channel and/or kerb and channel is constructed by an extrusion process, concrete shall comply with the prescription ordering requirements specified in AS 1379, with a maximum aggregate size not exceeding 20 mm and a minimum of 320 kg of cement per cubic metre of concrete. The extrusion machine shall be fitted with a tamper and an automatic control which allows adjustment of the position of the forming mould while the machine is in operation.

The horizontal and vertical alignments of kerb, channel and/or kerb and channel shall be controlled by means of a sensor working to a control line. The finished kerb, channel and/or kerb and channel shall be well compacted and shall have exposed surfaces free from voids and honeycombing.

Expansion joints shall be installed at regular intervals not exceeding 20 m. The joints shall be constructed by installing 6 mm maximum thickness compressible packing in the full cross-section of the kerb, channel and/or kerb and channel. Where relevant, joints shall be located to line up with expansion joints in adjacent structures.

Contraction joints between expansion joints shall be installed at regular intervals not exceeding 5 m. The joints shall be constructed by forming grooves 40 mm deep and not more than 6 mm wide in all exposed surfaces of the kerb, channel and/or kerb and channel. All grooves shall be normal to the top surface and square to the alignments of the kerb, channel and/or kerb and channel.

Concrete shall be cured for a period not less than seven days before any other roadworks operations are carried out adjacent to the kerb, channel or kerb and channel.

20.4 Tolerances

The horizontal and vertical alignments of kerb, channel and/or kerb and channel shall not vary from those specified by more than ± 10 mm.

Notwithstanding the above tolerances, the alignments of the kerb, channel and/or kerb and channel shall have smooth lines. The overall dimensions of the kerb, channel and/or kerb and channel shall nowhere be less than that specified in the drawings.

20.5 Water test

Where the longitudinal grade of channels is less than 1%, a test shall be carried out by discharging water into the channel to check uniformity of flow along the channel. After the flow has ceased, water shall not pond to a depth of more than 5 mm in any section of the channel. The test shall be carried out as soon as possible after the concrete in the channel has hardened. **Witness Point 1**

21 Precast concrete kerb, channel, and kerb and channel blocks

21.1 General

Clause 21 applies to the provision of precast concrete kerb, channel and kerb and channel blocks.

21.2 Material

Precast concrete kerb blocks and channel blocks shall be proprietary products manufactured in accordance with Clause 6.6.

Blocks installed on a horizontal alignment of radius 12 m or less shall be precast to the required radius or shall be straight blocks of dimensions which ensure the jointing requirements specified herein are complied with. Where blocks are precast to a radius, each shall be clearly marked to indicate its radius.

Epoxy adhesion agent shall be a suitable proprietary product.

Cement mortar shall comply with Clause 6.2.

21.3 Construction

Precast concrete kerb, channel and kerb and channel blocks shall be installed in the locations specified by, and in accordance with, the drawings.

Where insitu material on or against which precast blocks are to be installed is other than rock, the material shall be compacted as for material at the bottom of excavations in accordance with MRTS04 *General Earthworks*.

Where kerb, channel and kerb and channel blocks are to be fixed to the surface of asphalt or concrete, epoxy adhesion agent shall be employed. The epoxy adhesion agent shall be spread evenly over the whole of the contact surfaces.

Kerb, channel and kerb and channel blocks shall be laid on bedding of minimum thickness 50 mm.

Kerb, channel and kerb and channel blocks shall have watertight cement mortar joints. Cement mortar shall be used within one hour of mixing and shall not be re-tempered.

The joints shall be finished to give smooth surfaces uniform with the surfaces of the blocks. The thickness of joints shall not be less than 7 mm or greater than 13 mm. Exposed surfaces of blocks shall be cleaned of cement mortar coating as soon as possible after the joint mortar has hardened. No roadworks operations shall be carried out adjacent to the kerb, channel and kerb and channel blocks until 48 hours after its construction.

21.4 Tolerances

The tolerances for the finished work shall be as specified in Clause 20.4.

21.5 Water test

A water test as specified in Clause 20.5 shall be carried out on completed channel and kerb and channel blocks. **Witness Point 2**

22 Shoulder dykes

22.1 General

Clause 22 applies to the provision of shoulder dykes.

22.2 Material requirements

Compressible packing shall be bitumen impregnated fibre board or other equivalent packing.

Concrete shall comply with Clause 6.1.

Cement mortar shall comply with Clause 6.2.

Asphalt shall comply with MRTS30 *Asphalt Pavements*.

22.3 Construction

22.3.1 General

Shoulder dykes shall be constructed in the locations specified by, and in accordance with, the drawings.

22.3.2 Concrete shoulder dykes

Concrete shall comply with Clause 6.1.

The surface on which shoulder dykes are to be constructed shall be moistened just prior to placing concrete. Exposed surfaces shall have a steel-trowelled finish.

Where shoulder dykes are constructed by an extrusion process, the extrusion machine shall be fitted with a tamper and an automatic control which allows adjustment of position of the forming mould while the machine is in operation. The horizontal and vertical alignments of shoulder dykes shall be controlled by means of a sensor working to a control line. The finished shoulder dykes shall be well compacted and shall have exposed surfaces free from voids and honeycombing.

Expansion joints shall be installed at regular intervals not exceeding 20 m. The joints shall be constructed by installing 6 mm maximum thickness compressible packing in the full cross-section of the shoulder dykes.

Contraction joints between expansion joints shall be installed at regular intervals not exceeding 5 m. The joints shall be constructed by forming grooves 40 mm deep and not more than 6 mm wide in all exposed surfaces of the shoulder dykes. All grooves shall be normal to the top surface and square to the alignments of the shoulder dykes.

Concrete shall be cured for a period appropriate to the concrete mix and its application, but not less than seven days before any other roadwork operations are carried out adjacent to the shoulder dykes.

22.4 Asphalt shoulder dykes

Asphalt shoulder dykes shall comply with MRTS30 *Asphalt Pavements*.

22.4.1 Precast concrete block shoulder dykes

Precast concrete block shoulder dykes shall be in accordance with Clause 22.

22.5 Tolerances

The horizontal and vertical alignments of shoulder dykes shall not vary from those specified by more than ± 10 mm. Notwithstanding the above tolerances, the alignments of shoulder dykes shall have smooth lines. The overall dimensions of shoulder dykes shall nowhere be less than those specified.

23 Concrete gullies

23.1 General

Clause 23 applies to the provision of concrete gullies.

23.2 Material requirements

Concrete shall comply with Clause 6.1.

Cement mortar shall comply with Clause 6.2.

Precast concrete back-units for gullies shall be proprietary products manufactured in accordance with Clause 6.6.

Grates, covers and frames shall be reinforced concrete, mild steel or cast iron as specified in the drawings and/or Standard Drawings and shall comply with Clause 6.4.

Mild steel components shall comply with MRTS78 *Fabrication of Structural Steelwork*. Mild steel components shall be hot-dipped galvanised in accordance with AS/NZS 4680.

Cast iron components shall be fabricated from cast iron, grade T200 and shall comply with AS 1830.

23.3 Construction

Concrete gullies shall be provided in the locations specified by, and in accordance with, the drawings.

Where insitu material on or against which gullies are to be constructed is other than rock, the material shall be compacted as for material at the bottom of excavations in accordance with MRTS04 *General Earthworks*.

Concrete shall be in accordance with Clause 6.1.

Where the sides of excavations are in solid ground, the gully pits may be constructed without the use of backforms and concrete may be placed against the insitu material.

Where shafts are constructed without the use of backforms, the specified wall thickness shall be increased by not less than 25 mm to provide additional cover to reinforcement.

The joints between gullies and culverts shall be made watertight using cement mortar. The mortar shall be used within one hour of mixing and shall not be re-tempered. The joints shall be finished to provide smooth surfaces, uniform with the inner surfaces of the gullies.

Where backforms are used, they shall be removed and backfilling shall be undertaken in accordance with MRTS04 *General Earthworks*.

Concrete back-units and frames shall be joined to gullies using cement mortar. Exposed concrete surfaces shall be cleaned free of any cement mortar.

Grates and frames shall be installed as specified in the drawings and/or Standard Drawings.

Grates on gullies shall not be installed until all the surveying requirements have been met as specified in Clause 59 and notice of such works provided to the Administrator. **Hold Point 5**

23.4 Tolerances

23.4.1 Horizontal tolerances

The locations of gullies shall not vary from those specified in the drawings by more than ± 100 mm in the direction of the construction centre line and ± 50 mm in the direction at right angles to the construction centre line.

23.4.2 Vertical tolerances

The invert heights of gullies shall not vary from those specified by the drawings by more than ± 50 mm, provided always that the gullies join neatly to existing drainage structures, do not pond water unnecessarily and are at heights compatible with other adjacent structures. The heights of the tops of back-units, grates and frames shall not vary from those described in the drawings by more than ± 10 mm.

24 Insitu concrete access chambers

24.1 General

Clause 24 applies to the provision of access chambers.

24.2 Materials requirements

Concrete shall comply with Clause 6.1.

Cement mortar shall comply with Clause 6.2.

Step irons shall be heavily galvanised mild steel bars. Mild steel bars shall comply with AS/NZS 4671 and the step irons shall be galvanised in accordance with the requirements specified in AS/NZS 4680. The average coating mass shall be not less than 600 g/m².

Covers and frames shall be manufactured from cast iron, grade T200 and shall comply with AS 1830 and Clause 6.4 of this Technical Specification.

Precast components shall be in accordance with Standard Drawings 1307 and 1308.

Precast surrounds shall be proprietary products manufactured in accordance with Clause 6.6.

Epoxy mortar shall be a proprietary product.

24.3 Construction

Cast-in-place concrete access chambers shall be provided in the locations specified in, and in accordance with, the drawings.

Where insitu material on or against which access chambers are to be constructed is other than rock, the material shall be compacted as for material at the bottom of excavations in accordance with MRTS04 *General Earthworks*.

Concrete shall be in accordance with Clause 6.1.

Where the sides of excavations are in solid ground, the access chamber shafts may be constructed without the use of backforms. Where concrete is placed without the use of backforms, the specified wall thicknesses shall be increased by not less than 25 mm to provide additional cover to reinforcement.

The joints between access chambers and pipes shall be made watertight using cement mortar. The mortar shall be used within one hour of mixing and shall not be re-tempered. The joints shall be finished to provide smooth surfaces, uniform with the inner surfaces of the access chambers.

Concrete benching shall be shaped to the shapes specified by the drawings and/or Standard Drawings and shall have smooth, even surfaces and neat edges. Step irons shall be installed horizontal, vertically in line, and shall project uniformly from shafts.

Where step irons are not cast-in-place, they shall be epoxy mortared into drilled holes. The joints between the step irons and the shafts shall be completely filled so that the step irons are held rigid and the joints are watertight.

Concrete top slabs shall be joined to the shafts using cement mortar or epoxy mortar.

The opening in the top slab shall be closed with temporary covers, after which excavations shall be backfilled. Backfilling shall be undertaken in accordance with MRTS04 *General Earthworks*.

Frames shall be joined to the top slabs using cement mortar or epoxy mortar. Close-fitting units shall employ epoxy mortared joints only.

Cast insitu concrete surrounds shall be constructed on the top slabs to encase the frames. Alternatively, precast concrete surrounds may be installed using epoxy mortared joints.

Covers shall be installed in the frames.

For access chambers in roadworks, temporary covers shall remain in position and installation of the frames and surrounds shall be deferred until pavement construction has reached a stage where the frames and surrounds can be positioned accurately.

Concrete top slabs on insitu concrete access chambers shall not be placed until all the surveying requirements have been met as specified in Clause 59 and notice of such works provided to the Administrator. **Hold Point 6**

24.4 Tolerances

24.4.1 Horizontal tolerances

The locations of access chambers shall not vary from those specified in the drawings by more than ± 100 mm.

24.4.2 Vertical tolerances

The invert heights of access chambers shall not vary from those specified in the drawings by more than ± 50 mm, provided that the access chambers join neatly to existing drainage structures and are at heights compatible with other adjacent structures.

The heights of the tops of frames, surrounds and covers shall not vary from those specified in the drawings by more than ± 10 mm.

25 Precast concrete access chambers

25.1 General

Clause 25 applies to the provision of precast concrete access chambers.

25.2 Material requirements

Concrete shall comply with Clause 6.1.

Cement mortar shall comply with Clause 6.2.

Precast concrete access chambers shall be proprietary products manufactured in accordance with Clause 6.6.

Step irons shall be as specified in Clause 24.2.

Covers and frames shall be as specified in Clause 24.2.

Epoxy mortar shall be a suitable proprietary product.

25.3 Construction

Precast concrete access chambers shall be installed in the locations and in accordance with the drawings.

Where insitu material on or against which access chambers are to be constructed is other than rock, the material shall be compacted as for material at the bottom of excavations in accordance with MRTS04 *General Earthworks*.

Foundation bedding material shall be placed to provide continuous even support for the access chamber.

Concrete shall be in accordance with Clause 6.1.

Bases shall be of thickness not less than 150 mm and shall extend not less than 150 mm radially beyond the outside of the precast access chamber shafts.

The lowest precast concrete shaft section of the access chamber shall be bedded in the concrete base before the concrete in the base sets.

Openings for culverts shall be cored out of the shaft sections during manufacture or carefully broken out to avoid shaft fractures.

Minimum gaps of 25 mm shall be provided all around between connecting culverts and shaft sections.

Culverts shall be joined to shafts to form watertight joints using cement mortar. Cement mortar shall be used within one hour of mixing and shall not be re-tempered. The joints shall be finished to give smooth surfaces which are uniform with the surfaces of the shafts.

Concrete benching shall be shaped as specified in the drawings and/or Standard Drawings and shall have smooth, even surfaces and neat edges.

Precast concrete shaft sections shall be sealed with an epoxy compound in accordance with the manufacturer's instructions to produce watertight joints. The joints shall be pointed from the inside.

Step irons shall be horizontal, vertically in line and project uniformly from shafts. All holes shall be completely filled with cement mortar or epoxy mortar and all joints neatly pointed so that the step irons are rigid and the joints watertight.

Precast concrete top slabs shall be joined to the shafts using cement mortar or epoxy mortar.

After shafts have been completed and top slabs placed in position and closed with temporary covers, excavations shall be backfilled. Backfilling shall be undertaken in accordance with MRTS04 *General Earthworks*.

Precast concrete adjustment rings shall be joined to top slabs using cement mortar.

Frames shall be joined to adjustment rings using cement mortar or epoxy mortar. Concrete surrounds

shall be constructed on the adjustment rings to encase the frames. Covers shall be installed in the frames.

Temporary covers may be placed on the top slabs and fixing of the adjustment rings, frames and surrounds deferred until pavement construction has reached a stage when the adjustment rings, frames and surrounds can be finished accurately.

Concrete top slabs on precast concrete access chambers shall not be placed until all the surveying requirements have been met as specified in Clause 59 and notice of such works provided to the Administrator. **Hold Point 7**

25.4 Tolerances

The horizontal and vertical tolerances shall be as specified in Clause 24.4.

26 Precast concrete side inlet gullies

26.1 General

Clause 26 applies to the provision of precast concrete side inlet gullies.

26.2 Material requirements

Concrete shall comply with Clause 6.1.

Cement mortar shall comply with Clause 6.2.

Precast concrete side inlet gullies shall be proprietary products manufactured in accordance with Clause 6.6.

Precast concrete side inlet gullies shall be in accordance with Standard Drawings 1313, 1321, 1322, 1443 and 1444 as applicable.

Epoxy mortar shall be a suitable proprietary product.

Dowel pins shall be mild steel of minimum thickness 25 mm and hot-dipped galvanised as per AS/NZS 4680.

Grates and frames shall be in accordance with Standard Drawings 1321 and 1322.

26.3 Construction

26.3.1 General

Side inlet gullies shall be provided in the locations specified in the drawings and in accordance with the details shown on Standard Drawings 1321 and 1322.

Where insitu material on or against which gullies are to be constructed is other than rock, the material shall be compacted as for material at the bottom of excavations in accordance with MRTS04 *General Earthworks*.

Foundation bedding material shall be placed to provide continuous even support for the precast gully component.

Concrete shall comply with Clause 6.1.

Concrete benching shall be provided to gullies to the shapes specified in the Standard Drawings and shall have smooth, even surfaces and neat edges.

Culverts shall be joined to shafts/pits to form watertight joints using cement mortar. Cement mortar shall be used within one hour of mixing and shall not be re-tempered. The joints shall be finished to given smooth surfaces which are uniform with the surfaces of the shafts.

A precast concrete gully chamber and converter slab (if required) shall be joined to the shafts/pits using cement mortar or epoxy mortar.

After shafts or pits have been completed and a chamber placed in position and closed with temporary covers, excavations shall be backfilled. Backfilling shall be undertaken in accordance MRTS04 *General Earthworks*.

26.3.2 Precast shafts

The lowest precast concrete shaft section of gullies shall be bedded in the concrete base before the concrete in the base sets.

Openings for culverts shall be cored out of the shaft sections during manufacture or carefully broken out to avoid shaft fractures. Minimum gaps of 25 mm shall be provided all around between connecting culverts and shaft sections.

Joints in precast concrete shaft sections shall be sealed from the inside with an epoxy compound in accordance with the manufacturer's instructions to produce watertight joints.

26.4 Tolerances

The horizontal and vertical alignment of the side inlet gully shall not vary from those specified in the drawings by more than ± 10 mm.

Notwithstanding the above tolerances, the alignments of the side inlet gully shall have smooth lines.

The overall dimensions of any component shall be nowhere less than that specified on the applicable drawings or Standard Drawings.

26.5 Water test

A water test on a side inlet gully shall be carried out where the longitudinal grade is less than 1%.

Water shall be discharged into the side inlet gully to check uniformity of flow. After the flow has ceased, water shall not pond to a depth of more than 5 mm in any section of the channel.

The test shall be carried out as soon as possible after the concrete in the channel has cured.

Witness Point 3

27 Subsoil drains

27.1 General

Clause 27 applies to the provision of subsoil drains.

27.2 Materials requirements

27.2.1 Drainage pipes

Drainage pipes (perforated and unperforated) and associated fittings and jointing procedures shall comply with the following requirements:

- a) fibre reinforced concrete pipes – MRTS26 *Manufacture of Fibre Reinforced Concrete Drainage Pipes*

- b) corrugated steel pipes – AS/NZS 2041
- c) PVC pipes – AS/NZS 1254, and
- d) perforated plastic pipes – AS 2439.1.

27.2.2 Strip filter drains

Notwithstanding requirements to the contrary in this Clause 27.2, strip filter drains shall be a suitable proprietary product, comprising a plastic core of nominal thickness not less than 40 mm, encased by a non-woven geotextile which complies with the provisions of MRTS27 *Geotextiles (Separation and Filtration)*.

The strip filter drain shall permit the passage of high water flows along the drain, and shall have a crush strength not less than 200 kPa.

Textile sleeves shall be either seamless knitted proprietary products or be formed from woven geotextiles. The geotextile material in formed sleeves shall comply with the provisions of MRTS27 *Geotextiles (Separation and Filtration)*.

27.2.3 Geotextiles

Geotextiles shall be suitable proprietary products and shall comply with MRTS27 *Geotextiles (Separation and Filtration)*.

27.2.4 Trench backfill

Trench backfill material shall be crushed or granular material which conforms to the grading requirements stated in this clause.

For Type B subsoil drains, backfill material shall consist of a single-sized aggregate of 20 mm or 10 mm particle size, with a maximum of 5% passing the 0.150 mm test sieve.

For Type D subsoil drains, backfill material shall consist of coarse sand with 100% of material passing the 4.75 mm test sieve and not greater than 10% passing the 0.300 mm test sieve.

Alternatively, backfill to Type B subsoil drains may consist of no-fines concrete (nominal aggregate size 20 mm) which complies with Clause 26 of MRTS70 *Concrete*.

27.2.5 Concrete

Concrete shall comply with Clause 6.1.

Figure 27.2.5 – Subsoil drain types

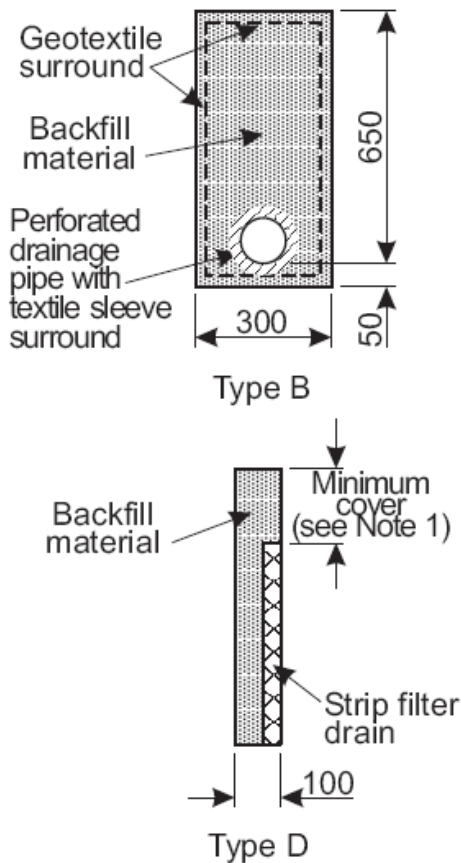

Notes:

1. Minimum cover for various compactors unless approved otherwise:
 Hand-held units: 100
 Units < 15 tonnes: 200
 Units > 15 tonnes: 300
2. All dimensions are in millimetres.

27.2.6 Marker posts

Marker posts shall be tubular steel and comply with the Standard Drawing 1356.

27.3 Storage of materials

Storage and handling of textile sleeves and strip filter drains shall be in accordance with the manufacturer’s recommendations. The drains shall not be exposed to heat or direct sunlight to the extent that their physical and/or mechanical properties are diminished.

Materials shall not be stored directly on the ground. Storage arrangements shall protect the materials from damage and soiling.

27.4 Construction

Subsoil drains shall be constructed in the locations and in accordance with the drawings.

Dimensions shall be in accordance with the requirements specified in Clause 27.2.5.

Subsoil drains shall be installed to the grades specified in the drawings. Where the grades are not specified, the bottom of trenches shall be trimmed to provide not less than 0.5% longitudinal fall

towards outlets for pipe-type drains, and not less than 1% longitudinal fall towards outlets for strip filter-type drains.

Clean-outs shall be located at the heads of all subsoil drains and at subsequent spacings not exceeding 60 m for pipe-type drains and 50 m for strip filter-type drains. Clean-outs shall be constructed in accordance with the details shown on Standard Drawing 1116.

Installation of filter fabric shall comply with MRTS27 *Geotextiles (Separation and Filtration)*.

Where an outlet, inlet, or clean-out pipe passes through the filter fabric, a separate piece of fabric of sufficient size shall be wrapped around the pipe and flared against the main fabric to provide an effective seal.

Subsoil drains shall be joined in accordance with the manufacturer's recommendations. Clean-out pipes shall be joined to the subsoil drains using oblique tee connections. Perforated fibre reinforced concrete and corrugated steel pipes shall be laid with the perforations so aligned as to provide the most efficient water entry.

Trench backfill material used where a textile sleeved drain or a strip filter drain is employed shall be damp when placed in the trench. The material shall be carefully placed in layers not exceeding 200 mm loose thickness and shall be tamped. Trench backfill material used where a geotextile trench surround is employed shall be compacted to achieve effective mechanical interlock between particles.

Where subsoil drains are constructed within the subgrade, they shall extend to the underside of the lowest pavement layer unless specified otherwise in the drawings.

Where subsoil drains are constructed outside the subgrade edge point, the trench backfill material shall be placed to within 150 mm of the ground or finished surface and the remaining 150 mm filled with impervious material compacted as for embankment material in accordance with MRTS04 *General Earthworks*.

Concrete outlets, concrete surrounds, galvanised chicken wire cones, pest-proof flaps, cast iron or PVC caps, grouted rock pitching, and marker posts shall be constructed and/or installed in accordance with Standard Drawing 1116.

Concrete shall comply with Clause 6.1.

Grouted rock pitching shall comply with Clause 40.

Marker posts shall be installed as specified in the drawings.

After the drains are constructed, they shall be flushed out. Flushing shall continue until the outlet water is clean and flows consistently. **Witness Point 4**

No construction equipment shall be permitted to stand or travel directly on completed subsoil drains.

28 Sheet or strip filter drains

28.1 General

Clause 28 applies to the provision of sheet and strip filter drains.

28.2 Material requirements

Sheet filter drains shall be a suitable proprietary product, comprising a plastic core of nominal thickness not less than 18 mm, encased by a non-woven geotextile which complies with MRTS27 *Geotextiles (Separation and Filtration)*.

Strip filter drains shall be a suitable proprietary product, comprising a plastic core of nominal thickness not less than 40 mm, designed to allow the drainage of water along the drain and encased by a non-woven geotextile which complies with MRTS27 *Geotextiles (Separation and Filtration)*.

The plastic core shall permit the passage of high water flows, and shall have a crush strength not less than 200 kPa.

Drainage pipes and fittings and associated joining materials/procedures shall comply with the requirements specified in the following references:

- a) fibre reinforced concrete pipes – MRTS26 *Manufacture of Fibre Reinforced Concrete Drainage Pipes*
- b) corrugated steel pipes – AS/NZS 2041
- c) PVC pipes – AS/NZS 1254, and
- d) perforated plastic pipes – AS 2439.1.

Concrete shall be grade N20/20 in accordance with Clause 6.1.

Marker posts shall be tubular steel and comply with the Standard Drawings.

28.3 Storage and handling of materials

Storage and handling of filter drain materials shall be in accordance with the manufacturer's recommendations. Materials shall not be exposed to heat or direct sunlight to the extent that their physical and/or mechanical properties are diminished.

Materials shall not be stored directly on the ground. The storage arrangements shall protect the materials from damage or soiling.

28.4 Construction

Sheet and/or strip filter drains shall be constructed in the locations and in accordance with the drawings.

Prefabricated sheet and/or strip filter drains and associated pipework shall be installed to the shapes and other requirements specified in the drawings, and fixed in position in accordance with the manufacturer's recommendations.

Sheet and/or strip filter drains shall be installed just ahead of other construction work which follows.

Any tearing or puncturing of the drain material shall be repaired.

Where sheet filter drains are used against structures employing weepholes, the core of the drain shall have cutouts of a size and spacing recommended by the manufacturer. The geotextile shall be left intact over these core cutouts.

Collector pipes shall be constructed to the shapes specified in the drawings and jointed in accordance with the manufacturer's recommendations.

Concrete ends to drainage outlets shall be in accordance with Clause 6.1.

Filling around collection pipes shall be general backfill material in accordance with Clause 20 of MRTS04 *General Earthworks*. Fill material shall be compacted to a relative compaction not less than 97%.

Marker posts shall be installed in accordance with the drawings.

Concrete outlets, concrete surrounds, galvanised chicken-wire cones and pest-proof flaps shall be provided in accordance with Standard Drawing 1116.

29 Vertical drains

29.1 General

Clause 29 applies to the provision of vertical wick filter and sand drains.

29.2 Material requirements

Vertical wick filter drains shall be in accordance with the drawings. Where plastic cores are specified, they shall be 100 mm wide and comprise a regular pattern, encased by a non-woven geotextile complying with MRTS27 *Geotextiles (Separation and Filtration)*. The drains shall have a discharge capacity (flow per unit hydraulic gradient) not less than 150 m³/year.

Sand drains shall be natural sand, manufactured sand or a mixture thereof and shall conform to the grading requirements shown in Table 29.2.

Table 29.2 – Sand drains – Grading

Test sieve size (mm)	Percent passing by mass
9.5	100
4.75	90–100
2.36	70–100
1.18	50–100
0.6	20–70
0.3	0–40
0.15	0–20
0.075	0–5

29.3 Construction

29.3.1 General

Vertical drains shall be constructed in the locations and in accordance with the drawings.

The proposed sequence for construction of the vertical drains shall be submitted to the Administrator for a direction as to its suitability at least 14 days before commencement of the work. **Milestone**

Vertical drains shall be straight, shall provide continuous drainage over the installed lengths, and shall be constructed in a manner which does not disturb the surrounding ground surface.

29.3.2 Special requirements for wick drains

To minimise disturbance of the subsoil, the cross-sectional area of the mandrel shall be as close to that of the drain as possible. As a guide, it is typical for the maximum cross-sectional area to be 65 cm². The mandrel shall also be sufficiently stiff to prevent wobble or deflection during installation.

The mandrel shall incorporate an anchor plate or similar arrangement at the bottom, the dimensions of which shall conform as closely as possible to the dimensions of the mandrel so as to minimise soil disturbance.

Installation techniques requiring driving shall not be used. Jetting techniques shall require the prior written approval of the Administrator. In no circumstances shall alternate raising or lowering of the mandrel during advancement be used. Raising of the mandrel shall be carried out only after completion of installation of a drain.

The rate of mandrel advance shall be controlled to avoid significant bending or deflection from the vertical. Penetration shall be uninterrupted and typical rates are approximately 0.15 m/sec to 0.60 m/sec. Drains shall be anchored and finished in accordance with the manufacturer's recommendations.

Splices in drains shall be made in a manner recommended by the manufacturer. Nevertheless, the jacket and core shall be overlapped a minimum of 150 mm at any splice.

Each installed drain shall not have more than one splice.

Wick drains shall be installed to the toe levels specified in the drawings. 300 mm of wick drain shall be embedded in the drainage blanket, with not less than 50 mm of material surrounding the wick drain.

29.3.3 Special requirements for sand drains

Sand drains may be constructed using displacement or replacement processes and shall be continuous for their full length.

Compaction of sand by vibration, tamping or other methods shall not be carried out.

After construction, the level of sand in the drains shall be monitored. Should the sand drop, the drains shall be topped up with additional sand.

29.4 Tolerances

The locations of drains shall not vary from those specified in the drawings by more than 200 mm.

The departure from verticality of any drain shall not exceed 1 horizontal to 50 vertical. A suitable means of assessing the verticality of the drain installation equipment shall be provided so that verticality may be checked at any time.

The diameter of constructed sand drains shall not vary from those specified by more than + 50 mm or - 20 mm.

30 Stone columns

30.1 General

Clause 30 applies to the provision of stone columns.

30.2 Construction procedure

The construction procedure shall comply with the details shown in the drawings.

The Contractor shall submit to the Administrator the procedure for constructing stone columns no less than 28 days before construction of the stone columns is to commence **Milestone**

The procedure shall include:

- a) details of all materials to be used, including embankment fill in the area immediately above the stone columns, and
- b) details of the method of construction of the stone columns and the equipment to be used.

Construction of stone columns shall not commence until the Administrator has deemed the construction procedure suitable to use **Hold Point 8**

30.3 Granular working platform

30.3.1 Materials

30.3.1.1 Granular material

The material for construction of granular working platforms shall be selected fill comprising stone aggregate consisting of sound crushed rock, crushed gravel or uncrushed gravel which is free from dust, clay, vegetable matter and other deleterious materials. It shall be at least a Type 4.5 unbound pavement material as defined in MRTS05 *Unbound Pavements*, with a maximum stone size of 50 mm. Additional properties may apply if stated in the drawings.

30.3.1.2 Geotextile

The geotextile fabric shall comply with MRTS27 *Geotextiles (Separation and Filtration)*.

30.3.1.3 Reinforcement geosynthetic material

Any reinforcement geosynthetic material shall comply with the drawings.

30.3.2 Construction

Where required by the drawings, a granular working platform shall be constructed prior to commencement of construction of the stone columns.

The surface of the entire area on which the granular platform is to be constructed shall be cleared and all objects shall be removed and disposed of.

The geotextile fabric shall be placed over the prepared area in accordance with the provisions of MRTS27 *Geotextiles (Separation and Filtration)*.

Where required by the drawings, a reinforcement geosynthetic material shall also be placed along with the geotextile fabric.

The moisture content of the granular material shall be not less than 85% of optimum moisture content (Standard compaction) and not more than 110% of optimum moisture content (Standard compaction) prior to delivery to the working platform area.

The granular material shall be dumped onto the geotextile in a manner which prevents damage to the geotextile fabric.

The granular material shall be compacted sufficiently to enable movement of construction equipment on its surface. The material shall be trimmed to the depth and profile specified in the drawings.

30.4 Stone columns

30.4.1 Materials

Stone columns shall be constructed from stone or crushed rock which has particle size distribution (Test Method AS 1141.11.1) in accordance with the grading requirements defined in Table 30.4.1.

Table 30.4.1 – Grading requirements

Test sieve size (mm)	Percent passing by mass
75	100
37.5	65–80
19	5–10
9.5	0–5

The stone or rock particles shall have a minimum particle density on a dry basis of 2.70 (Test Method AS 1141.6.1) and a maximum Los Angeles value of 35 (Test Method AS 1141.23).

30.4.2 Construction

During construction of the stone columns, the movement of construction equipment over the working platform shall be controlled in a manner which prevents undue distortion or damage to the geotextile fabric.

Columns shall be installed to the levels below existing ground level specified in the drawings.

All stone columns shall be vertical, straight and fully continuous over the full installed length. Columns shall conform to the diameter specified in the drawings.

Compaction to achieve a sound dense column of uniform diameter shall be achieved in a controlled manner. The material in the columns shall be compacted in a controlled manner to achieve a minimum density index of 70% when tested in accordance with Test Methods AS 1289.5.5.1 and AS 1289.5.6.1.

Adequate surface drainage shall be provided to ensure that the Site remains de-watered and safe for construction personnel and equipment. Adjoining areas shall not be contaminated by material displaced during the construction of the stone columns.

Immediately following completion of the stone columns, the surface shall be trimmed, cleaned and repaired as necessary without soil contamination of the stone columns. All mud, contaminated fill or aggregate, or other foreign material which has resulted from the process of construction of the stone columns, or associated activities, shall be removed. The surface shall be trimmed generally in accordance with the profile specified in the drawings. Undulations in the surface of the working platform shall be trimmed.

30.4.3 Tolerances

The position of the centreline of any individual column shall be within 200 mm of the set out position based on the adopted grid pattern specified in the drawings.

30.5 Construction of embankment

30.5.1 Materials

30.5.1.1 Embankment material

The material to be placed in the base layer for construction of the embankment immediately above the stone columns shall comply with Clause 15 of MRTS04 *General Earthworks* and any additional requirements specified in the drawings.

30.5.1.2 Geotextile

The geotextile fabric shall comply with MRTS27 *Geotextiles (Separation and Filtration)*.

30.5.2 Construction

Where specified in the drawings, a geotextile fabric shall be placed over the entire area on which the embankment fill is to be constructed in accordance with the provisions of MRTS27 *Geotextiles (Separation and Filtration)*.

The embankment fill material shall be placed over the working platform in layers not exceeding 150 mm uncompacted depth. Greater depths of fill may be used in the upper layers once stability of the fill has been established. Embankment fill shall be placed and compacted in accordance with Clause 15 of MRTS04 *General Earthworks* and any additional requirements specified in the drawings.

31 Concrete paved inverts in corrugated culverts

31.1 General

Clause 31 applies to the provision of concrete paved inverts in corrugated culverts.

31.2 Material requirements

Concrete shall comply with the requirements of Clause 6.1. Concrete shall be Class 32MPa/9.5.

Epoxy-based bonding agent shall be an approved proprietary product.

31.3 Construction

Concrete paved inverts shall be constructed in the locations and in accordance with the drawings.

The invert of corrugated steel and aluminium pipe culverts shall be lined with concrete with the following requirements:

- a) the minimum depth of concrete above the corrugations shall be 50 mm, and
- b) the minimum height of lining above invert shall be $D/6$ – where 'D' = Diameter of culvert.

The construction of paved inverts shall be delayed until all backfilling operations around and adjacent to the culverts concerned have been completed. Where practicable, the construction of paved inverts shall be delayed to the latest possible time within the construction period.

The surfaces on which paved inverts are to be constructed shall be dry and free of foreign matter.

Immediately prior to paving, the surfaces shall be coated with an epoxy-based bonding agent for the full width of the paved area, plus an additional 100 mm width each side.

Steel reinforcement shall be fastened to the culvert components in accordance with the culvert component manufacturer's drawings and recommendations.

Concrete work shall be in accordance with the requirements specified in Clause 6.1. The concrete shall be thoroughly worked into the corrugations, screeded off and trowelled to provide a uniform surface free of depressions.

The edges of the concrete paving shall be sloped such that water shall not pond against the steel culvert.

The surface of the trowelled concrete shall be scored longitudinally to a depth of 10 mm at 500 mm centres.

32 Linings in drains and channels

32.1 General

Clause 32 applies to the provision of linings in drains and channels.

32.2 Material requirements

Concrete shall comply with Clause 6.1.

Compressible packing shall be bitumen impregnated fibre board or other equivalent packing.

Materials for grouted rock pitching shall comply with Clause 40.

Materials for steel-wire mattresses shall comply with Clause 43.

32.3 Construction

Concrete linings in drains and channels shall be constructed in the locations and in accordance with the drawings.

Where insitu material on or against which linings are to be constructed is other than rock, the material shall be compacted as for material at the bottom of excavations in accordance with MRTS04 *General Earthworks*.

Concrete linings may be constructed without foundation bedding.

Concrete shall comply with Clause 6.1.

The surface of concrete linings shall be finished with a wood float and cured.

Expansion joints shall be constructed at regular intervals not exceeding 20 m by installing 6 mm maximum thickness compressible packing for the full cross-section of the berm drain.

Grouted rock pitching shall comply with Clause 40.

Steel-wire mattresses shall comply with Clause 43.

33 Berm drains

33.1 General

Clause 33 applies to the provision of berm drains.

33.2 Materials

Concrete shall comply with Clause 6.1 and shall be N25/20.

33.3 Construction

Berm drains shall be constructed in the locations and in accordance with the drawings.

Where insitu material on or against which linings are to be constructed is other than rock, the material shall be compacted as for material at the bottom of excavations in accordance with MRTS04 *General Earthworks*.

Berm drains shall be a nominal 100 mm deep when constructed.

Unreinforced concrete linings shall comply with Clause 32. Concrete lining shall be 100 mm thick.

34 Concrete margins and batters

34.1 General

Clause 34 applies to the provision of concrete margins and batters.

34.2 Material requirements

Concrete shall comply with Clause 6.1.

Steel sleeves shall comply with the drawings.

34.3 Construction

Concrete margins and batters shall be constructed in the locations and in accordance with the drawings.

Where the insitu material on or against which margins, batters and aprons are to be constructed is other than rock, the material shall be compacted as for material at the bottom of excavations in accordance with MRTS04 *General Earthworks*.

Concrete margins and batters may be constructed without foundation bedding.

Concrete shall comply with Clause 6.1.

Construction of concrete margins and batters shall include the construction of integral cut-off walls, the installation of steel sleeves, and the provision of weepholes.

35 Concrete rail track crossings and machinery crossings

35.1 General

Clause 35 applies to the provision of concrete rail track and machinery crossings.

35.2 Material requirements

Concrete shall comply with Clause 6.1.

Compressible packing shall be bitumen-impregnated fibre board or similar.

Joint sealing compound shall be bituminous putty or similar.

35.3 Construction

Concrete rail track and machinery crossings shall be constructed in the locations and in accordance with the drawings.

Where insitu material on or against which slabs are to be constructed is other than rock, the material shall be compacted as for material at the bottom of excavations in accordance with the requirements of MRTS04 *General Earthworks*.

Crossings shall be laid on foundation bedding.

Concrete work shall comply with Clause 6.1.

Saw-cut grooves shall be provided at the locations shown on the drawings.

Compressible packing shall be placed in accordance with the details shown on the drawings.

Construction joints and saw-cut grooves shall be sealed with joint sealing compound in accordance with the details shown on the drawings and the manufacturer's recommendations.

35.4 Tolerances

The horizontal dimensions measured at right angles from the construction centreline to edges of crossings shall not vary from those shown on the drawings by more than ± 25 mm.

Except where the provision of a smooth connection to existing structures dictates otherwise, the heights of the finished surfaces of crossings shall not vary from those shown on the drawings by more than ± 10 mm. In addition:

- a) the gap under a straight-edge 3.0 m long placed anywhere on the finished surfaces of the crossing shall not exceed 5 mm due allowance being made for the design shape, and
- b) the crossfalls of the finished surfaces shall not depart from those shown on the drawings by more than 0.5% absolute.

36 Hand-placed concrete paving

36.1 General

Clause 36 applies to the provision of hand-placed concrete paving.

36.2 Material requirements

Concrete shall comply with Clause 6.1.

Concrete to be pattern finished shall have coarse aggregate of size not greater than 20 mm.

Colouring agent shall be a colour curing compound from a suitable manufacturer.

Compressible packing shall be bitumen impregnated fibre board or other suitable packing.

36.3 Construction

Hand-placed concrete paving shall be constructed in the locations and in accordance with the drawings.

Where insitu material on or against which paving is to be constructed is other than rock, the material shall be compacted as for material at the bottom of excavations in accordance with MRTS04 *General Earthworks*.

Concrete paving shall not be constructed before ducting, pits, stormwater drainage, underground services and any bases for traffic signals, traffic signs, and street light poles within the area to be concreted have been installed.

Concrete shall comply with Clause 6.1.

Expansion joints shall be installed at regular intervals not exceeding 20 m longitudinally and transversely by installing 6 mm maximum thickness compressible packing in the full cross-section of the concrete paving. The joints shall be located to line up with expansion joints in adjacent structures where present.

Contraction joints shall be installed at regular intervals not exceeding 5 m longitudinally and also 5 m transversely between expansion joints by forming grooves 40 mm deep and not more than 6 mm wide in all exposed surfaces of the concrete paving. All grooves shall be normal to the top surface.

Concrete shall be cured for a period not less than seven days before any other operations are carried out adjacent to the work.

36.4 Colouring and finishing

Where specified, concrete paving shall be coloured. The surfaces of the concrete paving shall be uniform in colour.

Where specified, the surfaces of concrete paving shall be pattern finished. Areas not to be pattern finished shall be lightly broomed to produce uniform non-slip surfaces.

36.5 Vertical tolerances

The finished surfaces shall join neatly to edges of adjacent work.

Elsewhere the heights of the finished surface of concrete paving shall not vary from those specified in the drawings by more than ± 10 mm and, in addition, the gap under a straight-edge 3.0 m long placed anywhere on the finished surface of the concrete paving shall not exceed 5 mm due allowance being made for the design shape.

37 Sprayed concrete paving

37.1 General

Clause 37 applies to the provision of sprayed concrete paving.

37.2 Material requirements

Concrete shall comply with Clause 6.1 and shall be Class N25/10.

Compressible packing shall be bitumen impregnated fibre board or other suitable packing.

37.3 Construction

Sprayed concrete paving shall be constructed in the locations and in accordance with the drawings.

Where insitu material on or against which paving is to be constructed is other than rock, the material shall be compacted as for material at the bottom of excavations in accordance with MRTS04 *General Earthworks*.

Concrete paving shall not be constructed before ducting, pits, stormwater drainage, underground services and bases for traffic signals, traffic signs, and street light poles within the area to be concreted have been installed.

Concrete shall be in accordance with Clause 6.1.

Concrete paving shall be sprayed directly onto shaped and trimmed surfaces. The shaped and trimmed surfaces shall be dampened with water just prior to spraying the concrete paving.

The top surface shall be screeded and finished in accordance with Clause 20 of MRTS70 *Concrete*.

Expansion joints shall be installed at regular intervals not exceeding 20 m longitudinally and transversely by installing 6 mm maximum thickness compressible packing in the full cross-section of the concrete paving. The joints shall be located to line up with expansion joints in adjacent structures where present.

Contraction joints shall be installed at regular intervals not exceeding 5 m longitudinally and also 5 m transversely between expansion joints by forming grooves 40 mm deep and not more than 6 mm wide in all exposed surfaces of the concrete paving. All grooves shall be normal to the top surface.

Concrete shall be cured for a period appropriate to the concrete mix and its application before any other operations are carried out adjacent to the work.

37.4 Vertical tolerance

The finished surfaces shall join neatly to edges of adjacent work.

Elsewhere, the heights of the finished surfaces of concrete paving shall not vary from those specified by more than ± 10 mm and, in addition, the gap under a straight-edge 3.0 m long placed anywhere on the finished surface of the concrete paving shall not exceed 5 mm due allowance being made for the design shape.

38 Block paving

38.1 General

Clause 38 applies to the provision of block paving.

38.2 Material requirements

Paving blocks shall be as shown in the drawings. Colour, shape and strength shall be as specified in the drawings. Blocks shall be sound and free from cracks or other defects which would interfere with proper placing or impair the strength or permanence of construction or their appearance.

Bedding material shall be natural sand, free from soluble salts or other contaminants which would have a detrimental effect on the performance or appearance of the paving blocks. The material shall conform to the grading requirements shown in Table 38.2.

Concrete shall comply with Clause 6.1, except that the maximum aggregate size shall be 10 mm. Cement mortar shall comply with Clause 6.2.

Colouring agent shall be a colour curing compound.

Joint filling sand shall be a clean, sharp sand which is free of deleterious soluble salts or other contaminants likely to cause efflorescence or staining. The grading of the sand shall be such that 100% shall pass a 1.18 mm test sieve.

Table 38.2 – Block paving – bedding material grading

Test sieve size (mm)	Percent passing by mass
9.5	100
4.75	95–100
2.36	80–100
1.18	50–85
0.6	25–60
0.3	10–30
0.15	5–15
0.075	0–10

38.3 Construction

38.3.1 Block laying

Block paving shall be constructed in the locations and in accordance with the drawings.

Where insitu material on or against which paving is to be constructed is other than rock, the material shall be compacted as for material at the bottom of excavations in accordance with MRTS04 *General Earthworks*.

Block paving shall not be constructed before ducting, pits, stormwater drainage, underground services and any bases for traffic signals, traffic signs, and street light poles within the area to be paved have been installed.

Bedding material shall be spread loosely in a uniform layer and screeded to the shapes and heights which shall provide a depth of bedding not less than 25 mm or not more than 40 mm after the blocks have been laid and compacted.

Screeded sand shall be protected against pre-compaction. Any screeded sand which is pre-compacted prior to laying paving blocks shall be removed and replaced to shape.

Paving blocks shall be laid to the bond patterns specified in the drawings. All edge blocks shall abut an edge restraint. All full blocks in each row shall be laid first. Where practicable, closure blocks shall be cut and fitted subsequently in the gaps between blocks and edge restraints. Where this is not practicable, gaps shall be filled with concrete or cement mortar.

Where there is insufficient depth to pave over structures, concrete infills shall be placed over such structures in lieu of paving blocks. Moulds shall be used to form the required patterns in the surfaces of the infills.

Where coloured paving blocks are used, concrete infill and cement mortar shall be coloured to match the blocks.

Any pedestrian or barrow traffic which is required to move over the block paving prior to compaction of the paving shall use overlaying boards. No other traffic shall be allowed on the paving prior to its compaction.

38.3.2 Compaction

Compaction of paving blocks shall be carried out using vibrating plate compactors. The plate area of any compactor shall cover a minimum of 12 paving blocks. The frequency of vibration and the amplitude of the vibrating plate compactors shall be appropriate to the blocks being compacted.

Block paving shall be vibrated until no further lowering of the surface is evident.

Compaction shall proceed as closely as possible following placing of blocks. Compaction shall not be attempted within 1 m of the advancing edge during the placing of blocks.

Compaction shall continue until adjoining blocks are flush and to the required level.

Any blocks that are damaged shall be removed and replaced.

38.3.3 Joint filling

As soon as practicable after compaction and prior to termination of work on that day or use by traffic, sand for joint filling shall be spread over the block paving and broomed to fill the joints.

The surfaces of the block paving shall receive at least one further coverage (pass) of a vibrating plate compactor to achieve compaction of the joint filling sand.

Excess sand shall be removed from the surfaces by brooming.

38.4 Vertical tolerance

The finished surfaces shall join neatly to edge restraints.

Elsewhere the heights of the finished surfaces of block paving shall not vary from those specified in the drawings by more than ± 10 mm and, in addition, the gap under a straight-edge 3.0 m long placed anywhere on the finished surface of the block paving shall not exceed 5 mm due allowance being made for the design shape.

39 Rock masonry

39.1 General

Clause 39 applies to the provision of rock masonry. Rock masonry may also be referred to as 'rubble masonry'.

39.2 Material requirements

Rock for rock masonry shall be clean, hard, durable and free from seams or other imperfections. No weathered rock shall be used. Stones shall not be rounded on more than two sides or ends. No stones less than 0.003 m³ in volume shall be used except in the case of spalls for wedges. Stones greater than 0.3 m³ in volume shall not be incorporated in walls. The tightly-packed rock behind the piles, as shown in the Standard Drawing 2238, shall be 50 to 150 mm diameter.

Geotextile shall be the grade specified in the drawings and in accordance with MRTS27 *Geotextiles (Separation and Filtration)*.

Cement mortar for bedding shall consist of one part by volume of Type GP cement to three parts by volume of clean fine sand with only sufficient water added to achieve a plastic-like texture. Hydrated lime may be incorporated into the cement mortar to the extent of one part hydrated lime to 10 parts of Type GP cement (loose volume). Hydrated lime shall be an addition to, and not a replacement for, the cement. The mortar shall be able to retain its shape and not flow like a liquid. Materials shall comply with MRTS70 *Concrete*.

39.3 Construction

Rock masonry shall be constructed in the locations and in accordance with the drawings.

Rock masonry may be constructed without a foundation bedding. Rock shall be placed in cement mortar beds in horizontal layers. All rock shall be cleaned and thoroughly wetted before placing. Rocks shall be laid on mortar in horizontal beds with all exposed faces finished fair. All voids shall be filled with cement mortar and/or smaller size rock.

Cement mortar shall be used within one hour of mixing and shall not be re-tempered.

The exposed rock surface shall be cleaned free of any coating of cement mortar.

As an alternative to rock masonry walls, unreinforced concrete or plum concrete walls of N20/20 may be substituted. In this case, concrete shall comply with Clause 6.1.

40 Grouted rock pitching

40.1 General

Clause 40 applies to the provision of grouted rock pitching.

40.2 Material requirements

Rock (other than smaller-size rock required for wedging) shall be of size not less than 150 mm and not greater than 250 mm (minimum dimension). The rock shall be sound rock which does not disintegrate in water and which has been selected to match the existing rock pitching where appropriate.

Cement mortar for bedding shall consist of one part by volume of Type GP cement to three parts by volume of clean fine sand with only sufficient water added to achieve a plastic-like texture. Hydrated lime may be incorporated into the cement mortar to the extent of one part hydrated lime to 10 parts of Type GP cement (loose volume). Hydrated lime shall be an addition to, and not a replacement for, the cement. The mortar shall be able to retain its shape and not flow like a liquid. Materials shall comply with MRS70.

Sand bedding shall comply with Clause 19 of MRTS04 *General Earthworks*.

40.3 Construction

Grouted rock pitching shall be constructed in the locations and in accordance with the drawings.

Where insitu material on or against which the grouted rock pitching is to be constructed is other than rock, the material shall be compacted as for material at the bottom of excavations in accordance with MRTS04 *General Earthworks*.

The first row of rocks shall be placed on a sand bedding of minimum thickness 50 mm.

Rocks shall be placed so as to form irregular joints. All rocks shall be interlocked and wedged with smaller-size rock, as necessary, so that no single rock may be easily dislodged and no large voids remain between rocks. All rock pitched faces shall be stable prior to grouting with mortar.

Where rock pitching is constructed for batter protection, the toe rocks shall be of size not less than 250 mm.

The voids between rocks at the exposed surface shall be filled with cement mortar. The mortar shall be used within one hour of mixing and shall not be re-tempered.

Exposed surfaces shall have a relatively smooth, even, neat appearance. Where rock pitching is to be trafficable, care shall be taken to provide a smooth running surface.

Rock surfaces shall be cleaned free of any coating of cement mortar exposing the faces of the rocks.

41 Rock protection

41.1 General

Clause 41 applies to the provision of rock protection.

41.2 Material requirements

Rock employed for protection shall be as specified in the drawings or if not shown, rock used shall be of size not less than 150 mm and not greater than 500 mm. Rock shall be well graded with not less than 50% larger than a size twice the minimum size specified.

Rock shall be clean, hard, dense and durable igneous or Metamorphic rocks. In addition, it shall be resistant to weathering, free from overburden, spoil, shale and organic matter. Rock that is laminated, fractured, porous, with discontinuities or otherwise physically weak, shall not be used. Sedimentary rocks shall not be used.

The breadth or thickness of a single stone shall be not less than one-third its length.

41.3 Construction

Rock protection shall be constructed in the locations and in accordance with the drawings.

Rock protection shall have a uniform appearance overall, and shall not have noticeable overall irregularities in horizontal and vertical alignments.

Rock protection shall be placed in a manner which ensures that the larger rocks are uniformly distributed throughout the protection work, and that the smaller rocks effectively fill the spaces between the large rocks without leaving any large voids. The layers of placed rock shall be of even thickness and of even grading.

The placing operations shall minimise the chances of rock running loose and damaging adjacent areas. Rock deposited in areas outside the rock protection zone shall be recovered.

Where rock protection of embankments is specified, placement of the protection shall occur progressively along with the construction of the embankment such that at no time shall the constructed level of the rock protection be more than 1 m vertical height below the constructed level of the embankment.

42 Steel-wire gabion protection

42.1 General

Clause 42 applies to the provision of steel-wire gabion protection.

42.2 Material requirements

Steel-wire gabions shall be manufactured from heavily galvanised, hexagonally woven, steel-wire mesh having a wire diameter not less than 2.7 mm and a mesh opening of 80 mm across the flats of the hexagon. Selvedge wire shall have a diameter not less than 3.4 mm and binding wire shall have a diameter not less than 2.2 mm. All wire shall comply with AS 2338 and AS 2423. Galvanising shall be in accordance with the requirements specified in AS/NZS 4680. Where specified, the wire shall have a black PVC or other durable plastic coating of nominal thickness 0.55 mm, minimum thickness 0.4 mm.

Rock shall be sound igneous or metamorphic rock that shall not disintegrate in water or when exposed to the weather. Rock used for filling shall be of size not less than 120 mm and not greater than 200 mm. The rock shall be uniformly graded, and not less than 80% by number shall be of size greater than 150 mm. Rocks shall, where possible, be cubical, but in no case shall their least dimensions be less than half their greatest dimension.

42.3 Basic gabion requirements

Gabions shall have an appropriate mesh size to retain the rock filling. Gabion panels and diaphragms shall be selvedged. The selvedge wire shall be woven integrally with the mesh or fastened to the mesh either by binding the edges of the mesh about the selvedge wire or by stainless steel clips, all in accordance with the manufacturer's recommendations.

Sufficient binding wire shall be available for binding and tying operations.

42.4 Construction

Steel-wire gabion protection shall be constructed in the locations and in accordance with the drawings.

The areas on which gabions are to be positioned shall be trimmed to the shapes specified within a tolerance of ± 50 mm. Trimmed surfaces shall be free of roots, stumps, brush, rocks and like protrusions.

Gabion protection shall be constructed to the shapes and other requirements specified herein.

42.4.1 Assembling, positioning and joining gabions

Gabions shall be assembled in accordance with the manufacturer's recommendations. Assembled gabions shall be positioned empty in the locations required for the finished work.

The first row of gabions shall be securely positioned and filled before gabions in other rows are positioned. Other gabions may then be positioned, joined and filled as the work requires. Joining shall be affected by binding or clipping the gabions together in accordance with the manufacturer's recommendations.

42.4.2 Forming shapes

Where necessary, the mesh panels shall be cut, folded and tied together to form mitre joints, angles, curves, slopes and other non-rectangular shapes. Surplus mesh shall be completely cut out or be folded back on and neatly tied to an adjacent gabion face. Cut or folded edges shall be selvaged. Adjacent cut or folded edges shall be bound or clipped together in accordance with the manufacturer's recommendations.

42.4.3 Rock filling

The gabion shall have a dense, evenly distributed filling with minimum voids, and shall not be significantly distorted in shape. Where necessary, the outer and inner panels of gabions shall be tied together during the placing operation to minimise distortion, especially when diaphragms are not employed. Care shall be taken to avoid damaging the gabion mesh and any geotextile placed under the gabions.

42.4.4 Closing gabions

Gabions shall be closed as soon as practicable after filling. All lids shall be securely bound to edges and diaphragms in accordance with the manufacturer's recommendations.

43 Steel-wire mattress protection

43.1 General

Clause 43 applies to the provision of steel-wire mattress protection.

43.2 Material requirements

43.2.1 General

Wire mattresses shall be either proprietary products or non-proprietary products constructed as shown in the drawings.

43.2.2 Proprietary mattresses

Proprietary mattresses shall be manufactured from heavily galvanised, hexagonally woven, steel-wire mesh having a wire diameter not less than 2 mm and a mesh opening of 60 mm across the flats of the hexagon. Selvedge wire shall have a diameter not less than 2.4 mm and binding wire shall have a diameter not less than 2.0 mm. All wire shall comply with AS 2338 and AS 2423. Galvanising shall be in accordance with AS/NZS 4680. Where specified, the wire shall have a black PVC or other durable plastic coating of nominal thickness 0.55 mm, minimum thickness 0.4 mm.

All panels in proprietary products shall be selvedged. The selvedge wire may be woven integrally with the mesh or fastened to the mesh either by binding the edges of the mesh about the selvedge wire or by using stainless steel clips, all in accordance with the manufacturer's recommendations.

Sufficient binding wire shall be available for binding and tying operations.

Anchor plates shall be fabricated from grade 250 commercial quality steel and galvanised. All plates shall comply with AS 3678 and AS 3679.1. All sharp edges and curves shall be ground smooth prior to galvanising. Galvanising shall be in accordance with AS/NZS 4680. Galvanising shall be carried out after cutting and drilling of the plates.

Anchor bolts securing anchor plates to concrete shall be supplied in accordance with the details specified. Anchor pickets shall be star pickets 1.8 m long.

Mattresses shall have an appropriate mesh size to retain the rock filling.

43.2.3 Non-proprietary mattresses

Non-proprietary products shall be constructed from 1.8 m minimum width rolls of chain wire mesh. Diaphragms are not required in this form of mattress.

43.3 Rock

Rock shall be sound igneous or metamorphic rock that shall not disintegrate in water or when exposed to the weather. Rock used for filling shall be of size not less than 75 mm and not greater than 150 mm. The rock shall be uniformly graded, and not less than 80% by number shall be of a size greater than 100 mm. Rock shall, where possible, be cubical, but in no case shall their least dimension be less than half their greatest dimension.

43.4 Anchor pickets

Anchor pickets shall be 12 mm minimum in diameter and 1.8 m minimum in length. Material grade shall be R250N, hot dip galvanised in accordance with MRTS71 *Reinforcing Steel* and AS/NZS 4680.

43.5 Construction

43.5.1 General

Steel-wire mattress protection shall be constructed in the locations and in accordance with the drawings.

The areas on which mattresses are to be positioned shall be trimmed to the shapes specified within a tolerance of + 50 mm to -50 mm, except where the provision of such tolerances shall not permit the tops of mattresses to join neatly to the inverts of adjacent culverts. Trimmed surfaces shall be free of roots, stumps, brush, rocks and like protrusions. Mattress protection shall be constructed to the shapes and to other requirements specified herein.

43.5.2 Installing anchors

43.5.2.1 Anchor plates

Where specified, anchor plates and bolts shall be installed to secure mattresses to structures.

43.5.2.2 Anchor pickets

Where specified, anchor pickets shall be employed to secure mattress protection. Such pickets shall be installed prior to placing mattresses, and shall be positioned along the line of the upstream edge of mattresses placed on stream beds, and along the line of the top edge of mattresses placed on sloped areas. Nominal spacing of pickets shall be 1 m.

Where geotextiles are employed under mattresses, neatly cut openings shall be made in the geotextile at the appropriate locations to permit insertion of pickets.

The tops of the installed pickets shall finish level with the tops of the mattresses. Pickets which cannot be driven full depth shall be cut off level with the tops of the mattresses.

43.5.3 Assembling, positioning and joining mattresses

43.5.3.1 Proprietary wire mattresses

Proprietary wire mattresses shall be assembled in accordance with the manufacturer's drawings and recommendations.

Assembled mattresses shall be positioned empty in the locations required for the finished work.

The first row of mattresses shall be securely positioned and filled before mattresses in other rows are placed, joined and filled.

The corners and all diaphragm points along the side of the first row of assembled mattresses shall be tied to the anchor plates and anchor pickets prior to placing rock filling. Mattresses in other rows may be positioned, joined and filled as the work requires. The joining of mattresses shall be in accordance with the manufacturer's recommendations.

43.5.3.2 Non-proprietary wire mattresses

Lengths of chain wire mesh shall be laid out flat on the ground surface and stretched sufficiently to remove any kinks and bends. Each length shall be sufficient to provide for the top, bottom and two ends.

The chain wire mesh shall be positioned length transverse to the direction of flow, leaving a top section of the mesh to be turned over to complete the mattress.

The bottom and ends of each length of chain wire mesh shall be bound to adjacent lengths through each individual mesh in turn.

The outermost lengths of mesh shall be cut and shaped such that part of the bottom may be folded up to form end panels of height equal to the thickness of the mattress.

Wire ties, not less than 1.6 mm diameter and having sufficient length to secure the top of the mattress, shall be provided at 500 mm intervals in each direction along the bottom of the mattress.

43.5.4 Forming shapes

Where necessary, mattresses shall be neatly cut, folded and tied together to form mitre joints, angles, curves, slopes and other shapes not possible to obtain using rectangular units. Surplus mesh shall be

completely cut out or folded back on and neatly tied to an adjacent mattress face. Cut or folded edges of adjacent mattresses shall be securely bound or clipped together.

43.5.5 Tensioning of mattresses

Unfilled, positioned mattresses shall be tensioned using a wire strainer or by winching. The stretching apparatus shall be firmly attached to the free end of the assembled mattress. The tensioning process shall in no way distort the mattress shape. Adjacent mattresses shall be securely bound together along the top, bottom and sides while under tension.

43.5.6 Rock filling

Rock filling shall be placed while mattresses are under tension. Rock filling of mattresses shall be carried out entirely by mechanical methods. The method of placing rock in mattresses shall produce a dense, evenly distributed filling with minimum voids and minimum distortion of the mattress shape. Care shall be taken to avoid damaging the mattresses and any geotextile under the mattresses. Tension on the mattresses shall be released only when the mattresses have sufficient rock filling to prevent the mesh from slackening after release.

43.5.7 Closing mattresses

Mattresses shall be closed and lids and top sections tied down as soon as practicable after filling.

Tying of proprietary mattresses shall be in accordance with the manufacturer's recommendations. Tying of non-proprietary mattresses shall be carried out in a suitable manner. The top section of each mattress shall be turned over the rock filling and securely bound to the bottom. Each top section shall be bound to adjacent top sections through each mesh in turn. The free end and sides of the outermost top sections shall similarly be bound to the top and side edges of the end panels.

44 Fabric-encased concrete batter protection

44.1 General

Clause 44 applies to the provision of fabric-encased concrete batter protection.

44.2 Materials

44.2.1 Fabric

Fabric material shall consist of multiple panels of double-layer open selvage fabric jointed in a mat configuration. The two layers shall be heavily ultraviolet stabilised continuous filament nylon tyre cord, of which at least 50% by weight shall be textured.

Fabric shall be filter point mattress and shall meet the minimum requirements for tensile strength and porosity stated in Table 44.2.1.

Table 44.2.1 – Properties of fabric for encased batter protection

Property	Value
Tensile strength – warp and weft	900 N per 25 mm (D5034-09 and D5035-06(2008)e1)
Porosity	3 m ³ /min (D737-04(2008)e1)
Colour	Pigment added green or brown as approved by the Administrator

44.2.2 Concrete

Concrete shall comply with MRTS70 *Concrete*. Concrete shall consist of a mixture of fine aggregate, cement and water proportioned to provide a pumpable slurry.

The minimum 28 day compressive strength of concrete shall be 25 MPa.

44.3 Construction

44.3.1 General

Fabric-encased concrete batter protection shall be constructed in the locations and in accordance with the details shown on the drawings.

44.3.2 Placement of mats

Fabric mats shall be positioned as shown on the drawings on batter slopes and in excavations for cut-off walls.

Grouting shall not commence until fabric units have been positioned correctly. **Hold Point 9**

44.3.3 Grouting

Grout shall be introduced into the space between the layers of fabric in such a manner as to provide a uniform average thickness of mat. Sufficient inspections or tests shall be carried out to ensure the requirements of the Technical Specification are being achieved.

The average thickness of the concrete mat shall be not less than that stated in Clause 4 of Annexure MRTS03.1.

The Contractor shall demonstrate that the specified average thickness has been achieved by calculating the volume of grout used and the area of the mat.

45 Bridge abutment protection Type 1 – rock spillthrough

45.1 General

Clause 45 applies to the provision of rock spillthrough protection at bridge abutments.

45.2 Material requirements

Rock employed for protection shall be as specified in the drawings or, if not so shown, rock used shall be of size not less than 150 mm and not greater than 500 mm. Rock shall be well graded with not less than 50% larger than a size twice the minimum size specified.

Rock shall be clean, hard, dense and durable. In addition, it shall be resistant to weathering, free from overburden, spoil, shale and organic matter. Rock that is laminated, fractured, porous, or otherwise physically weak, shall not be used.

The breadth or thickness of a single stone shall be not less than one-third its length.

Rock for the hand-packed face shall be of a size and shape necessary to provide the finish specified in Clause 45.3.

Cement mortar shall consist of one part by volume of Type GP cement to three parts by volume of clean fine sand with only sufficient water added to achieve a plastic-like texture. Hydrated lime may be incorporated into the cement mortar to the extent of one part hydrated lime to 10 parts of Type GP

cement (loose volume). Hydrated lime shall be an addition to, and not a replacement for, the cement. The mortar shall be able to retain its shape and not flow like a liquid.

45.3 Construction

Rock spillthrough protection shall be constructed in the locations and in accordance with the drawings or, where not specifically detailed, in accordance with the details shown on Standard Drawings 2232 and 2233.

The toe wall shall be constructed to the width and depth shown on the drawings in rock masonry in accordance with Clause 39 except that the rock shall comply with the requirements of Clause 45.2.

Rock spillthrough material shall be placed in a manner which ensures that the larger rocks are uniformly distributed throughout the spillthrough zone, and that the smaller rocks effectively fill the spaces between the large rocks without leaving any large voids. The layers of placed rock shall be of even thickness and of even grading.

The placing operations shall minimise the chances of rock running loose and damaging adjacent areas. Rock deposited in areas outside the rock spillthrough zone shall be recovered.

In addition, the face of rock spillthrough shall be hand-packed with selected smaller rock and grouted with cement mortar to give a relatively smooth and even appearance. Excess mortar shall be removed from the rock faces before it hardens.

46 Bridge abutment protection Type 2 – reinforced concrete over earth spillthrough

46.1 General

Clause 46 applies to the provision of reinforced concrete protection at bridge abutment earth spillthrough embankments.

46.2 Material requirements

Concrete shall be N25/20 and shall comply with Clause 6.1.

Welded steel-wire reinforcing fabric shall be as shown in the drawings or, where not shown, shall be F52. It shall be hot-dipped galvanised in accordance with AS/NZS 4680.

Compressible packing shall be 10 mm thick bitumen impregnated fibre board or other suitable packing.

46.3 Construction

Reinforced concrete protection shall be constructed in the locations and in accordance with the drawings or, where not specifically detailed, in accordance with the details shown on Standard Drawings 2234 and 2235.

Embankment faces shall be slightly overfilled during embankment construction and trimmed to the correct profile just before placing the reinforced concrete protection. Cut faces shall be trimmed neatly to the lines specified in the drawings. The trimmed face shall be lightly compacted.

The embankment face shall be true to line such that the deviation of the ground surface from a 3 m straight-edge held in any direction does not exceed 25 mm.

Faces of curved embankments shall be either a smooth curve or formed in a series of straights of approximately equal size. Curved faces of embankment shall conform to the above 25 mm maximum

deviation when a 3 m straight-edge is placed up the sloping face, and in the horizontal direction shall form a smooth curve.

Where the embankment faces are to be filled to achieve the above specified surface, the fill material shall be either no-fines concrete as specified in Clause 26 of MRTS70 *Concrete* or dry stabilised sand in accordance with Clause 19 of MRTS04 *General Earthworks*. The stabilised sand shall be dampened sufficiently so that it remains in place. Where no-fines concrete is used, extreme care shall be taken to achieve the specified surface profile.

The toe wall shall be constructed to the width and depth specified in the drawings and shall be reinforced with welded steel-wire reinforcing fabric.

The embankment face shall be boxed if necessary. If no boxing is used, screed boards or level pins shall be installed to ensure an accurate surface profile and to maintain the depth on concrete specified in the drawings. Level pins shall be hot-dipped galvanised 12 mm diameter steel reinforcing bar of sufficient length to be accurately located by driving into the embankment face.

Welded steel-wire reinforcing fabric shall be placed with a minimum cover of 75 mm from the embankment face.

Concrete shall be placed and compacted over the embankment face in accordance with MRTS70 *Concrete*.

The surface of the concrete shall be finished with a wooden float to give a uniform appearance. The surface shall be joint trowelled to give a blockwork appearance with joints at approximately 1.5 m centres.

Where a slab is more than 12 m wide on the plane face (not including curved faces at the edges), vertical expansion joints shall be formed at 6 m to 9 m centres. Reinforcement shall not be continuous through these joints.

Where the face of a curved embankment is formed in a series of straights, contraction joints shall be formed at the junction between adjacent straight segments of concrete slab.

Expansion joints shall be formed full depth using compressible packing.

Contraction joints shall be constructed by forming grooves 40 mm deep and not more than 6 mm wide in the surface of the slab.

46.4 Tolerances

The tolerances of the finished surface shall be such that the gap beneath a straight-edge 3.0 m long placed anywhere on the finished surface shall not exceed 25 mm due allowance being made for the design shape, where relevant.

47 Bridge abutment protection Type 4 – rockwork over earth spillthrough

47.1 General

Clause 47 applies to the provision of rockwork protection at bridge abutment earth spillthrough embankments.

47.2 Material requirements

Rock shall be sound igneous or metamorphic rock that shall not disintegrate in water or when exposed to the weather. Rock shall be free from overburden, spoil, shale and organic matter. Rock that is laminated, fractured, porous, or otherwise physically weak, shall not be used.

Rock shall be of a size not less than 200 mm and the least dimension of any rock shall be not less than half its greatest dimension.

Cement mortar shall consist of one part by volume of Type GP cement to three parts by volume of clean fine sand with only sufficient water added to achieve a plastic-like texture. Hydrated lime may be incorporated into the cement mortar to the extent of one part hydrated lime to 10 parts of Type GP cement (loose volume). Hydrated lime shall be an addition to, and not a replacement for, the cement. The mortar shall be able to retain its shape and not flow like a liquid. Materials shall comply with MRTS70 *Concrete*.

47.3 Construction

Rockwork protection shall be constructed in the locations and in accordance with the drawings or, where not specifically detailed, in accordance with the details shown on Standard Drawings 2236 and 2237.

The toe wall shall be constructed to the width and depth specified in the drawings in rock masonry in accordance with Clause 39, except that the rock shall comply with Clause 47.2.

Rock material shall be placed in a manner which ensures that the larger rocks are uniformly distributed throughout the rockwork layer, and that the smaller rocks effectively fill the spaces between the large rocks without leaving any large voids. The layers of placed rock shall be of even thickness and of even grading.

The placing operations shall minimise the chances of rock running loose and damaging adjacent areas. Rock deposited in areas outside the rock spillthrough zone shall be recovered.

In addition, the face of rock spillthrough shall be hand-packed with selected smaller rock and grouted with cement mortar to give a relatively smooth and even appearance. Excess mortar shall be removed from the rock faces before it hardens.

48 Bridge abutment protection Type 6 – interlocking blockwork over earth spillthrough

48.1 General

Clause 48 applies to the provision of interlocking blockwork protection at bridge abutment earth spillthrough embankments.

48.2 Material requirements

Blocks shall be interlocking blocks manufactured from concrete with nominal dimensions of either:

- a) 610 mm length, 150 mm breadth and 115 mm thickness, or
- b) 440 mm x 500 mm module, 100 mm thick.

The concrete strength shall be a minimum of N25 at 28 days. The minimum mass of the interlocking block shall be 170 kg/m².

Approved products are listed in Clause 5 of Annexure MRTS03.1. Full technical details of proposed alternative products may be submitted to the Administrator for approval at least 14 days prior to commencement of installation **Milestone**

Construction shall not commence until the Administrator has approved the type of interlocking block. **Hold Point 10**

Interlocking blocks shall be as specified in the drawings.

Stabilised sand comply with MRTS04 *General Earthworks*.

Geotextile fabric shall comply with MRTS27 *Geotextiles (Separation and Filtration)*.

Slotted UPVC drainage pipe shall comply with AS 2439.1.

48.3 Construction

Interlocking blockwork protection shall be constructed in the locations and in accordance with the drawings.

Embankment faces shall be slightly overfilled during embankment construction and trimmed to the correct profile just before laying the interlocking blockwork protection. Cut faces shall be trimmed neatly to the lines specified in the drawings. The trimmed face shall be lightly compacted.

The embankment face shall be true to line such that the deviation of the ground surface from a three metre straight-edge held in any direction does not exceed 25 mm.

Faces of curved embankments shall be either a smooth curve or formed in a series of straights of approximately equal size. Curved faces of embankment shall conform to the above 25 mm deviation when a three metre straight-edge is placed up the sloping face, and in the horizontal direction shall form a smooth curve.

Where the embankment faces are to be filled to achieve the above specified surface, the fill material shall be either no-fines concrete as specified in Clause 26 of MRTS70 *Concrete* or dry stabilised sand in accordance with Clause 19 of MRTS04 *General Earthworks*. The stabilised sand shall be dampened sufficiently so that it remains in place. Where no-fines concrete is used, extreme care shall be taken to achieve the specified surface profile.

A stabilised sand layer with a minimum thickness of 50 mm shall be placed over the entire surface area to be covered with interlocking blocks and shall comply with MRTS04 *General Earthworks*.

The concrete toe wall and edge strip shall be constructed to the dimensions specified in the drawings. Concrete shall be N32/20 and concrete shall comply with Clause 6.1.

Where the face of a curved embankment is formed in a series of straights, the straight segments shall be separated by concrete mid walls. Concrete end walls shall be constructed to confine the interlocking blockwork. Mid-walls and end walls shall be provided as specified in the drawings.

A slotted UPVC drainage pipe shall be installed as specified in the drawings.

After the slope surface and the concrete base have been constructed, a geotextile filter mat shall be spread over the prepared slope in accordance with the manufacturer's recommendations.

The interlocking blocks shall be placed on the filter mat such that the 610 mm dimension of the block is horizontal. Where necessary, the blocks shall be cut to fit the profiles of the mid-walls, end walls and capping concrete.

A concrete capping shall be installed above the top row of interlocking blocks.

48.4 Tolerances

The tolerances of the finished surface shall be such that the gap beneath a straight-edge 3.0 m long placed anywhere on the finished surface shall not exceed 25 mm due allowance being made for the design shape, where relevant.

49 Bridge abutment protection Type 7 – Rock-filled gabion protection

49.1 General

Clause 49 applies to the provision of rock-filled gabion protection for bridge abutment spillthrough embankment fill. Unless specified otherwise in drawings, rock filled gabion protection for height up to 6 metres shall be in accordance with Standard Drawing 2241.

49.2 Material requirements

Concrete for mass concrete toe shall be N25/20 and shall comply with Clause 6.1.

Concrete for concrete capping shall be S32/20 and shall comply with Clause 6.1. Welded steel-wire reinforcing fabric shall be SL82 and shall be hot-dipped galvanised in accordance with AS/NZS 4680.

Type B subsoil drainage shall comply with Clause 27. Perforated drainage pipe shall be 100 mm in diameter.

Rock armour protection shall comply with Clause 41.

Rock fill gabion toe, boxes and basket shall comply with Clause 42.

Mattress toe protection shall comply with Clause 43.

Cement stabilised sand shall comply with MRTS04 *General Earthworks*.

Geotextile filter material shall be Filtration Class 3, Strength Class D and shall comply with MRTS27 *Geotextiles (Separation and Filtration)*.

Compressible filler shall comply with MRTS77 *Bridge Deck*.

Medium impact polythene sheet separator (builders film) shall be 200 µm thick.

49.3 Construction requirements

Rock-filled gabion protection (Type 7) shall be constructed at the locations shown and in accordance with the drawings.

Embankment faces shall be slightly overfilled during embankment construction and trimmed to the correct profile before placing the rock-filled gabion protection. The trimmed face shall be levelled and lightly compacted.

Rock-filled gabion protection shall be constructed to the shapes and dimensions shown in the drawings. Gabion boxes of each row of the protection shall be staggered as practical as possible. Each gabion box in the protection shall be adequately laced with adjoining boxes to avoid separation in accordance with Gabion supplier's gabion installation manual.

Gabion toe shall be constructed to the dimensions shown in the drawings. If mass concrete toe is specified in the drawings, where toe is permanently underwater, the contractor shall develop a method statement for construction of mass concrete toe and cement stabilised sand layer and submit to

Administrator for acceptance at least 14 days before commencement of the protection. **Hold Point 11**
 Dewatering and cofferdam may be required. Cement-stabilised sand shall be constructed to form a foundation layer for construction of the mattress toe protection to the details shown in the drawings.

Mattress toe protection shall be constructed to the extent and dimensions shown in the drawings and shall comply with Clause 43. The mattress shall extend below the gabion for sufficient anchorage as shown in the drawings.

Type B subsoil drainage shall be constructed to the details shown in the drawings to avoid excessive hydrostatic pressure developed behind the toe. Appropriate grading shall be maintained for subsoil drains and appropriate outlets shall be provided.

Rock armour protection shall be constructed to the extent shown in the drawings. Geotextile layer shall be extended below the rock armour protection where shown in the drawings. Rock armour protection shall be constructed to form a transition from the Gabion or mattress protection to the road embankment or existing ground. This is to prevent undermining of the abutment protection during flood events.

Concrete capping for bearing inspection shall be constructed on the top most gabion box to the details shown in the drawings. Medium impact polythene sheet separator shall be laid on the rock fill of the gabion box prior to concreting and in accordance with the Manufacturer's recommendations. The top rock layers in these boxes shall be packed to the approximate required level to lay the polythene separator.

Compressible filler shall be installed between abutment and the gabion protection to the details shown in the drawings and in accordance with the Manufacturer's recommendations.

50 Shotcreting

50.1 General

Clause 50 applies to the provision of shotcreting.

50.2 Material requirements

50.2.1 Shotcrete

Shotcreting concrete shall be in accordance with MRTS70 *Concrete*. Aggregate size and slump shall be chosen to suit the requirements of the shotcreting pump. Concrete grade shall be in accordance with the drawings. Minimum concrete grade shall be S32.

Grade of concrete to be specified on the drawings as per the required design life and the exposure classification of the application. Slope protections are generally 50-year design life, therefore S32 concrete is required.

Design life of wall-facing of soil nail retaining walls require 100-year and minimum exposure classification of B2 with minimum concrete grade of S40.

50.2.2 Steel reinforcing

Steel reinforcement shall be in accordance with drawings. Welded steel-wire reinforcing fabric shall be minimum SL82 in accordance with MRTS71 *Reinforcing Steel* and shall be hot-dipped galvanised in accordance with AS/NZS 4680.

50.2.3 Fixing pins

Fixing pins shall be 1.0 m long N12 steel reinforcing bars conforming to the requirements of MRTS71 *Reinforcing Steel* and shall be hot-dipped galvanised in accordance with AS/NZS 4680. Bending operations, where required, shall be carried out prior to hot-dipped galvanising.

50.3 Construction

Shotcrete protection shall be constructed in the locations and in accordance with the details specified in the drawings.

Shotcrete shall be provided by an experienced operating crew. Equipment for shotcreting shall be such as to ensure thorough mixing, delivery, discharge, placing and finishing of shotcrete.

Shotcrete shall be of uniform construction and appearance.

For newly-constructed embankments, faces shall be slightly overfilled during embankment construction and trimmed to the correct profile just before placing the shotcrete protection. The trimmed face shall be lightly compacted. Cut faces shall be trimmed neatly to the lines specified in the drawings.

Faces of curved embankments shall be either a smooth curve or formed in a series of straights of approximately equal size.

Cut-off walls shall be provided on all free edges of the shotcreted slab and shall be constructed with the slab. Cutoff walls shall be 300 mm thick and shall be reinforced with welded steel-wire reinforcing fabric. The base cut-off wall shall be 1000 mm deep and the top and side cut-off walls shall each be 600 mm deep.

Thickness of the shotcrete shall be as specified in the drawings. Minimum shotcrete thickness for slope protections or similar applications in exposure classification B1 shall be 120 mm and 160 mm for shotcreting for wall-facing slab of soil nail walls in exposure classification B2. Thickness shall be increased to meet cover requirements for higher exposure classifications.

Slope protections of minimum 50-year design life require cover to reinforcement in accordance with AS 3600. For applications in exposure classification B1, cover against the soil to be 60 mm and other areas 40 mm. This needs 120 mm minimum shotcrete thickness. Similarly, shotcreting facing slabs for soil nail retaining walls or similar applications require 100-year design life and minimum exposure classification of B2. Therefore, cover to reinforcement to be in accordance with AS 5100 and cover against the soil side to be 85 mm and on other areas 55 mm. This require minimum thickness of 160 mm.

Contraction joints shall be installed in the direction of the dip of the batter only at a maximum spacing of 4 m or as otherwise specified in the drawings. Contraction joints shall extend for the full depth of the slab and the reinforcing fabric shall be discontinued at the joints.

Weep holes shall be provided as specified in the drawings.

The finished concrete surface shall be of neat appearance with lines generally conforming to the surface levels – i.e., flat surfaces on straight batters and curved surfaces where batters are curved. The top surface shall be screeded and finished in accordance with Clause 20 of MRTS70 *Concrete*. All surfaces shall be finished with a wood float and broom finish.

All rebound, overspray, dumped and cut-out concrete material shall be cleared and removed from the Site.

Curing of shotcrete shall comply with MRTS70 *Concrete*. However, membrane curing shall not be used to surfaces that shall be covered by an additional layer of shotcrete.

50.4 Tolerances

The tolerances of the finished surface shall be such that the gap beneath a straight-edge 3.0 m long placed anywhere on the finished surface shall not exceed 25 mm due allowance being made for the design shape where relevant.

51 Concrete retaining walls

51.1 General

Clause 51 applies to the provision of concrete retaining walls.

51.2 Material requirements

Concrete shall be as shown on the drawings or, where not so shown, it shall be N32/20 in accordance with Clause 6.1.

Steel reinforcing shall comply with MRTS71 *Reinforcing Steel*.

Inserts shall be in accordance with the details specified.

Compressible packing shall be bitumen impregnated fibre board or other suitable packing.

Joint sealing compound shall be bituminous putty or other suitable joint sealing compound.

51.3 Construction

Concrete retaining walls shall be constructed in the locations and in accordance with the drawings.

Where insitu material on which footings are to be constructed is other than rock, the material shall be compacted as for material at the bottom of excavations in accordance with MRTS04 *General Earthworks*.

Footings shall be constructed without foundation bedding.

Concrete shall comply with Clause 6.1, except as specified otherwise in this clause.

Construction of the walls shall include the provision of inserts where these are specified in the drawings.

Expansion joints shall be installed in the locations specified in the drawings using compressible packing. Contraction joints shall be installed in the locations specified in the drawings.

Expansion and contraction joints shall be sealed with joint sealing compound in accordance with the drawings and the manufacturer's recommendations.

Cast-in-place concrete walls shall be cured for a period of not less than 28 days prior to the construction of backfilling against the walls.

Backfilling on the concrete retaining wall footing shall not be placed until all the surveying requirements have been met as specified in Clause 59 and notice of such works provided to the Administrator. **Hold Point 12**

51.4 Tolerances

The horizontal alignment of cast-in-place concrete walls shall not depart from that specified in the drawings by more than ± 10 mm.

The heights of the tops of the walls shall not depart from those specified in the drawings by more than ± 20 mm, except where the provision of such tolerances shall not permit the top to join neatly to adjacent structures.

52 Concrete masonry retaining walls

52.1 General

Clause 52 applies to the provision of concrete retaining walls.

52.2 Material requirements

Masonry units shall comply with the general requirements specified in AS/NZS 4455.1. The units shall have the following properties:

- a) strength classification – Grade 15, and
- b) total water absorption – not greater than 210 kg/m³.

Steel reinforcing shall comply with MRTS71 *Reinforcing Steel*.

Concrete shall be N25/20 and in accordance with Clause 6.1.

Concrete infill shall be N25/20 and shall have a maximum slump within the range 100 mm to 150 mm immediately prior to placing.

Cement mortar for bedding shall consist of one part by volume of Type GP cement to three parts by volume of clean fine sand with only sufficient water added to achieve a plastic-like texture. Hydrated lime may be incorporated into the cement mortar to the extent of one part hydrated lime to 10 parts of Type GP cement (loose volume). Hydrated lime shall be an addition to, and not a replacement for, the cement. Materials shall comply with MRTS70 *Concrete*.

Inserts shall be in accordance with the drawings.

Compressible packing shall be bitumen impregnated fibre board or other suitable packing.

Joint sealing compound shall be bituminous putty or other suitable joint sealing compound.

52.3 Construction

Concrete masonry retaining walls shall be constructed in the locations and in accordance with the drawings.

Where insitu material on which footings are to be constructed is other than rock, the material shall be compacted as for material at the bottom of excavations in accordance with MRTS04 *General Earthworks*.

Footings may be constructed without foundation bedding.

Concrete in footings shall comply with Clause 6.1. Concrete footings shall be cured for a period not less than two days before any masonry units are placed on them.

Concrete masonry unit retaining walls shall be constructed to the details specified in AS 3700.

All masonry units shall be laid in stretcher bond using cement mortar and 10 mm joints. Cement mortar for joints shall be used within one hour of mixing and shall not be re-tempered.

Construction of the walls shall include the provision of inserts where these are specified in the drawings.

Expansion joints shall be installed in the locations specified in the drawings using compressible packing. Contraction joints shall be installed in the locations specified in the drawings.

Expansion and contraction joints shall be sealed with joint sealing compound in accordance with the drawings and the manufacturer's recommendations.

The cores of placed masonry units shall be completely filled with a concrete infill, placed and compacted in accordance with Clause 6.1. Prior to commencement of filling, the cores shall be cleaned of any surplus mortar.

Steel reinforcing shall be placed in accordance with the drawings and the recommendations of the manufacturer of the masonry units.

Masonry unit retaining walls shall be capped with a cement mortar capping not less than 25 mm thick. Tops of cappings shall be trowelled to provide smooth, even surfaces with neat edges. Alternatively, the walls may be capped with capping blocks mortared in position.

Exposed wall faces and capping blocks shall be cleaned free of cement mortar and infill concrete.

Concrete masonry unit walls shall be cured for a period of not less than 28 days prior to the construction of backfilling against the walls.

52.4 Tolerances

The horizontal alignment of cast-in-place concrete walls shall not depart from that specified in the drawings by more than ± 10 mm.

The heights of the tops of the walls shall not depart from those specified in the drawings by more than ± 20 mm, except where the provision of such tolerances shall not permit the top to join neatly to adjacent structures.

The thickness of mortar joints shall not vary from that specified by more than ± 3 mm.

53 Crib walls

53.1 General

Clause 53 applies to the provision of crib walls.

53.2 Material requirements

Crib units shall be proprietary products manufactured in accordance with Clause 6.6.

Backfilling material shall be free draining granular material conforming to Clause 19 of MRTS04 *General Earthworks*.

53.3 Construction

Crib walls shall be constructed in the locations and in accordance with the details shown on the drawings.

Where insitu material on which footings are to be constructed is other than rock, the material shall be compacted as for material at the bottom of excavations in accordance with MRTS04 *General Earthworks*.

Footings may be constructed without foundation bedding.

Concrete in footings shall comply with Clause 6.1. Concrete footings shall be cured for not less than two days before any crib units are placed on them.

Crib units shall be installed in accordance with the manufacturer's recommendations.

Following the installation of crib units in each course of the wall, backfilling material shall be placed in and behind the crib units, as specified in the manufacturer's recommendations, and thoroughly compacted using appropriate mechanical tampers.

53.4 Tolerances

The horizontal alignment of crib walls shall not depart from that specified by more than ± 20 mm.

The heights of the tops of the walls shall not depart from those specified by more than ± 20 mm, except where the provision of such tolerances shall not permit the tops to join to adjacent structures neatly.

54 Boulder retaining walls

54.1 Boulder retaining walls

54.1.1 General

Clause 54 applies to the provision of boulder retaining walls.

54.2 Material requirements

54.2.1 Rock fill

- a) Rock fill must be sound igneous, metamorphic or approved sedimentary rock (as per MRTS04 *General Earthworks*) that must meet the minimum requirements of Table 54.2.1 below.

Table 54.2.1 – Properties of rock fill

Property	Test Method	Limit
Apparent particle density	AS 1141.6.1	2.60 t/m ³ minimum
Point load strength index Is(50)	AS 4133.4.1	1.0 MPa minimum
Los Angeles value	AS 1141.23	25% maximum
Total weighted loss (five cycles)	AS 1141.24	5% maximum
Water absorption	AS 1141.6.1	2.0% maximum

- b) Rock must be fresh or slightly weathered and not rounded.
- c) For the selected source of rock fill – i.e., quarry, the contractor must develop a methodology outlining the quality assurance procedures that would be adopted to manage the production of rock fill meeting the stipulated requirements described in this Technical Specification.

- d) The shape and size of rock must comply with the following:
 - i. nearly cubic rock where possible
 - ii. rock with a ratio of maximum to minimum dimension of not greater than three
 - iii. at least two split faces
 - iv. the minimum dimension of a boulder shall be 0.5 m, and
 - v. multiple blocks at any given cross section is not permitted.

54.2.2 Drainage blanket

- a) A drainage blanket of minimum width 300 mm must be placed behind the boulder wall to act as permanent drainage to the adjacent fill material. Material in the drainage blanket must be sound, durable, fresh, angular and semi-rounded or rounded stone. The rock size shall comply with the size limitations in Table 54.2.2 below.

Table 54.2.2 – Grading requirements for drainage blanket

Stone size (mm)	Percent finer
150	100
75	90-100
50	30-60
26.5	0-5
19	0-2

- b) The geosynthetic separator to be used at the drainage blanket/backfill interface must conform to Technical Specification MRTS27 *Geotextiles (Separation and Filtration)*.

54.2.3 Packing stones in boulder walls

Packing stones or rock wedges may be needed to bed boulder wall rocks tightly or to level rocks for subsequent courses. This material must meet the Technical Specification for Drainage Blanket (see Table 54.2.2 above).

54.2.4 Foundation

Select granular fill must be used to replace unsuitable material under the boulder wall footing if intersected below footing level. The select granular fill shall comply with the following:

- a) maximum size: 100 mm
- b) soaked CBR: 15%.

54.3 Construction

54.3.1 Foundation construction requirements

The foundation of the boulder walls must be inspected by the Contractor's RPEQ Geotechnical Engineer to ensure that the allowable bearing capacity of the exposed foundation meets the design requirements. Where the exposed foundations have an allowable bearing capacity less than the design allowable bearing capacity, the weak material must be excavated and replaced with select granular materials (see 'Foundation' in Clause 54.2.4) to the extent necessary to provide the required foundation at the base of the boulder wall.

54.3.2 Boulder wall placement

Rock fill must be placed so that they interlock with each other. This must be achieved by the following measures:

- a) The first row of boulder (rock fill) must be placed on a binding layer of 150 mm minimum thickness of 20 MPa/20 concrete or better. The rock fill within the depth of embedment must be set in concrete.
- b) All boulders must be placed with the minimum dimension vertical; multiple blocks along the width and elevation is not permitted.
- c) Vertical joints between adjacent boulders, in the longitudinal direction of the wall, must be staggered between successive courses by a distance not less than 300 mm.
- d) Vertical joints between adjacent boulders, in the cross-section of the wall, must be staggered between successive courses by a distance not less than 300 mm.
- e) Placement of the boulders must be progressive along the wall length so as to minimise voids. Packing Stone (see Section 54.2.3) may be used to correct uneven surfaces and to prevent rocking.
- f) The extent of contact at any interface between boulders of the adjacent courses in a cross-section must be not less than 75% of the width of the particular interface in the cross-section.
- g) Adjacent boulders must touch:
 - i. The face of the wall must have a uniform appearance for the full visible height by suitable selection from a stockpile. Boulders of similar exposed end dimensions must be placed as uniformly as practicable along the length and height of the wall.
 - ii. Placement of boulders must be subject to daily inspections by the Contractor's RPEQ Geotechnical Engineer.

54.3.3 Backfill compaction

Compaction of backfill adjacent to the boulder wall/drainage blanket must conform to the requirements of Table 15.2 in Technical Specification MRTS04 *General Earthworks*, with the exception that the compaction of the backfill shall be carried out with no relaxation of compaction requirements adjacent to the wall. Light compaction equipment as per MRTS03 *Drainage, Retaining Structures and Protective Treatments* shall be used for compaction of back fill. The wall must be designed to accommodate this compaction-induced thrust.

54.3.4 Concrete slurry fill

The voids between the boulders must be filled with slurry concrete (slump greater than 100 mm) to the level of the adjacent ground where shown on the drawings.

54.3.5 Seepage drains

- a) Seepage drains using slotted PVC (minimum 100 mm diameter) must be placed at not more than 10 m centres to link the drainage blanket through the boulder wall to an outlet at the face of the wall.

- b) Backfill around the PVC drain must be screened gravel of 20 mm nominal size and must completely surround the pipe with a geotextile (as per MRTS03 *Drainage, Retaining Structures and Protective Treatments*) forming the interface with the backfill.
- c) The boulder course above the pipe must span over the pipe between adjacent boulders.

54.3.6 Surface runoff behind the wall

Positive measures must be taken to discharge the surface runoff and must not be allowed to infiltrate into the backfill.

54.4 Tolerances

- a) The horizontal tolerance for the front face of the wall must be constructed to within +/- 150 mm from the sloping face defined on the drawings.
- b) The thickness of the wall at any cross-section should not be less than that shown on the drawings.
- c) It is the responsibility of the contractor to set out the wall alignment and shape. The contractor must provide the equipment or tools for the control of the lines and levels (templates, string lines, etc.) and this equipment must remain on site.

55 Soil nailing

55.1 General

Clause 55 applies to the provision of soil nailing.

55.2 Methodology and construction procedure

The performance provisions of Clause 55 shall be the minimum requirements which apply to the installation of soil nails. The Contractor's installation methodology may differ from the prescriptive provisions of Clause 55, provided that such methodology can be shown to have been proven by previous field use by the subcontract installer.

At least 14 days prior to commencing any work which involves the installation of soil nails, the Contractor shall submit to the Administrator a construction procedure which details the method of drilling, installation, grouting and testing of the soil nails. **Milestone**

No work which involves the installation of soil nails shall be commenced until the Administrator has deemed the construction procedure suitable to use. **Hold Point 13**

55.3 Material requirements

55.3.1 Soil nails

Soil nails shall be manufactured from Grade D500N deformed reinforcing bar conforming to MRTS71 *Reinforcing Steel*. The length of soil nails shall be as specified in the drawings.

All permanent soil nails shall be hot dip galvanised to AS/NZS 4680 and shall be encapsulated by a completely waterproof corrugated plastic sheath. The sheath shall be made from PVC or HDPE tube, with a minimum uniform thickness of at least 2 mm. The size of the sheath shall be such as to ensure a 10 mm minimum grout annulus surrounding the reinforcing bar. A sacrificial grout tube reaching to the bottom end of the sheath shall be provided. Where possible, corrugated plastic sheath shall be unjointed for the full length of soil nail. Where necessary, sheath joints shall be achieved by lapping of at least 50 mm together with liberal use of solvent glues appropriate for the sheathing material.

After galvanising, soil nails shall be passivated by dipping in a 2% solution of sodium dichromate to prevent any adverse reactions between the zinc coating and the cement grout.

55.3.2 Spacers

Spacers shall be provided to ensure that the nail and the sheathing are centrally located within the hole and provided with a minimum of 30 mm of grout cover. Spacers shall also be provided to ensure that all sheaths if specified in the design are centrally located within the hole and provided with a minimum of 10 mm grout cover. Spacers shall be provided at both ends (within 300 mm from the ends) of nail and at 750 mm intervals (maximum) along the nail between the end spacers. The spacers shall be fabricated from materials which have no deleterious effect on the soil nail system. Spacers shall be manufactured to permit the free flow of grout.

55.3.3 Cement grout

Cement grout shall comply with Clause 6.3. In addition it shall have a minimum characteristic strength of 32 MPa.

55.4 Construction

55.4.1 General

Soil nails shall be installed in the locations and in accordance with the details specified in the drawings.

55.4.2 Drilling

The minimum diameter of hole for soil nails shall be 125 mm. The directions and the depths of the hole shall be as specified in the drawings.

Plant employing water as the drill flushing medium shall not be used as this can result in saturation of the soil surrounding the nail and the subsequent instability of the finished retaining structure.

55.4.3 Installation of soil nails

A sacrificial grout tube shall be attached to the bottom end of the soil nail. The soil nail shall be carefully positioned into the hole with a minimum of disturbance to the surrounding soil material.

55.4.4 Grouting of soil nails

55.4.4.1 Equipment

Grouting equipment shall include:

- a) a purpose-designed grout mixer of the continuous high speed type operating in the range of 1500 to 2000 rpm and producing grout free from lumps
- b) a holding tank fitted with an agitator
- c) a grout pump with a sustained outlet pressure of at least 400 kPa and fitted with a bypass back to the agitator tank, and
- d) a grout delivery line fitted with a gauge reading accurately to 1000 kPa.

55.4.4.2 Operations

Grouting of the soil nails shall be performed in the presence of the Administrator. **Hold Point 14**

Grout shall be pumped into the hole through the grout tubes until grout is forced out of the top of the hole. The level of grout inside and outside the sheath shall be kept approximately equal to avoid damage to the sheath. The amount of grout pumped into the hole shall be recorded to determine if the hole is blocked or if there are voids in the grout. Each soil nail shall be completely and continuously surrounded by a grout annulus.

55.5 Acceptance testing of soil nails

Testing of the soil nails shall be carried out and test result included in the quality records. Acceptance of test results for soil nails shall be subject to the approval of the Designer. **Hold Point 15**

The number of nails to be tested is as stated in Table 55.5.

Table 55.5 – Number of soil nails to be tested

No. of soil nails	Minimum number of pull-out tests
< 50	3
51–100	6
> 100	6%

The test procedure shall be:

- a) The grout shall have a minimum strength of 20 MPa and be at least four days of age.
- b) The test load shall be 1.5 times the working load which shall be as specified in the drawings.
- c) The test load shall be measured with an accuracy of ± 1 kN.
- d) The test frame used to mount the testing jack shall have supports such that it does not load the retained face at any localised point.
- e) Dial gauges used to record deflection of the soil nail shall be accurate to at least 0.01 mm.
- f) The soil nail shall be loaded to 20% of the test load, which point shall be recorded as the datum for deflection measurements.
- g) The remaining test load shall be applied in three equal increments and deflection measurements shall be recorded at each stage. The full test load shall be maintained for one hour.
- h) Three complete cycles of the test load shall be applied sequentially, and
- i) The test shall be considered successful if the deflection of the soil nail after three cycles does not exceed 0.1% of its length.

56 Passive rock dowels

56.1 General

Clause 56 applies to the provision of passive rock dowels.

56.2 Methodology and construction procedure

The performance provisions of Clause 56 shall be the minimum requirements which apply to the installation of passive rock dowels. The Contractor's installation methodology may differ from the prescriptive provisions of Clause 55 provided that such methodology can be shown to have been proven by previous field use by the subcontract installer.

At least 14 days prior to commencing any work which involves the installation of passive rock dowels, the Contractor shall submit to the Administrator a construction procedure which details the method of drilling, installation, grouting and testing of the rock dowels. **Milestone**

No work which involves the installation of passive rock dowels shall be commenced until the Administrator has deemed the construction procedure suitable to use. **Hold Point 16**

56.3 Materials

56.3.1 Passive rock dowels

Passive rock dowels shall be fabricated from Grade 500N deformed steel reinforcing bar conforming to MRTS71 *Reinforcing Steel* and shall be hot-dipped galvanised in accordance with AS/NZS 4680. The length of passive rock dowels shall be as specified in the drawings.

After galvanising, dowels shall be passivated by dipping in a 0.2% solution of sodium dichromate to prevent any adverse reactions between the zinc coating and the cement grout.

The dowels shall be encapsulated by a completely waterproof corrugated PVC or HDPE sheath of 2 mm minimum thickness. The size of the sheath shall be such as to ensure a 10 mm minimum grout annulus surrounding the reinforcing bar. A sacrificial grout tube reaching to the bottom end of the sheath shall be provided. All welds in the sheath and end caps and between the sheath and grout tube shall be water tested to prove their integrity.

A sacrificial grout tube shall also be securely attached externally to the bottom end of the sheath.

56.3.2 Spacers

Spacers shall be provided to ensure that the dowel and the sheathing are centrally located within the hole and provided with a minimum of 30 mm of grout cover. Spacers shall also be provided to ensure that all sheaths if specified in the design are centrally located within the hole and provided with a minimum of 10 mm grout cover. Spacers shall be provided at both ends (within 300 mm from the ends) of nail and at 750 mm intervals (maximum) along the nail between the end spacers.

The spacers shall be fabricated from materials which have no deleterious effect on the soil nail system. Spacers shall be manufactured to permit the free flow of grout.

56.3.3 Cement grout

Cement grout shall conform to Clause 6.3. In addition, it shall have a minimum characteristic strength of 40 MPa.

56.4 Construction

56.4.1 General

Rock dowels shall be installed in the locations and in accordance with the drawings.

56.4.2 Drilling

Holes for rock dowels shall be drilled to a minimum of 125 mm diameter in the directions and to the depths specified in the drawings.

The plant used to drill the holes into the rock face shall employ percussion drilling techniques and use air as the drill flushing medium. Water shall not be used as this can result in excess water pressures building up within the rock mass and cause instability of the rock slope.

56.4.3 Installation of rock dowels

The rock dowel shall be carefully positioned into the hole without damaging the encapsulating sheath or the grout tubes.

56.4.4 Grouting

56.4.4.1 Equipment

Grouting equipment shall include:

- a) a purpose-designed grout mixer of the continuous high speed type operating in the range of 1500 to 2000 rpm and producing grout free from lumps
- b) a holding tank fitted with an agitator
- c) a grout pump with a sustained outlet pressure of at least 400 kPa and fitted with a bypass back to the agitator tank, and
- d) a grout delivery line fitted with a gauge reading accurately to 1000 kPa.

56.4.4.2 Operations

Grouting of the rock dowels shall be performed in the presence of the Administrator. **Hold Point 17**

Grout shall be pumped into the hole through the grout tubes until grout is forced out of the top of the hole. The level of grout inside and outside the sheath shall be kept approximately equal to avoid damage to the sheath. The amount of grout pumped into the hole shall be recorded to determine if the hole is blocked or if there are voids in the grout. As the rock is likely to contain defects or voids, grout losses shall be expected. Each rock bolt shall be completely and continuously surrounded by a grout annulus.

56.5 Acceptance testing of passive rock dowels

Testing of the rock dowels shall be carried out and test results included in the quality records.

Acceptance of test results for soil nails shall be subject to the approval of the Designer. **Hold Point 18**

The number of dowels to be tested shall be as stated in Table 56.5.

Table 56.5 – Number of rock dowels to be tested

No. of rock dowels	Minimum number of pull-out tests
< 50	3
51–100	6
> 100	6%

The test procedure shall be:

- a) The grout shall have a minimum strength of 25 MPa and be at least five days of age.
- b) The test load shall be 1.5 times the working load which shall be as specified in the drawings.
- c) The test load shall be measured with an accuracy of ± 1 kN.
- d) The test frame used to mount the testing jack shall have supports such that it does not load the retained face at any localised point.
- e) Dial gauges used to record deflection of the soil nail shall be accurate to at least 0.01 mm.

- f) The rock dowel shall be loaded to 20% of the test load, which point shall be recorded as the datum for deflection measurements.
- g) The remaining test load shall be applied in three equal increments and deflection measurements shall be recorded at each stage. The full test load shall be maintained for one hour.
- h) Three complete cycles of the test load shall be applied sequentially, and
- i) The test shall be considered successful if the deflection of the rock dowel after three cycles does not exceed 0.1% of its length.

57 Active rock bolts

57.1 General

Clause 57 applies to the provision of active rock bolting.

57.2 Methodology and construction procedure

The performance provisions of Clause 56 shall be the minimum requirements which apply to the installation of active rock bolts. The Contractor's installation methodology may differ from the prescriptive provisions of Clause 55 provided that such methodology can be shown to have been proven by previous field use by the subcontract installer.

At least 14 days prior to commencing any work which involves the installation of active rock bolts, the Contractor shall submit to the Administrator a construction procedure which details the method of drilling, installation, grouting, stressing and testing of the rock bolts. **Milestone**

No work which involves the installation of active rock bolts shall be commenced until the Administrator has deemed the construction procedure suitable to use. **Hold Point 19**

57.3 Materials

57.3.1 Active rock bolts

Active rock bolts shall be manufactured from 26 mm diameter, 575 kN ultimate capacity steel stress bar. The length of active rock bolts shall be as specified in the drawings.

Each bar shall be encapsulated in PVC or HDPE corrugated sheath having an internal diameter of 65 mm, an external diameter of 85 mm and a minimum thickness of 2 mm. A sacrificial grout tube reaching to the bottom end of the sheath shall be provided. All welds in the sheath and end caps and between the sheath and grout tube shall be water tested to prove their integrity.

A sacrificial grout tube shall also be securely attached externally to the bottom end of the sheath.

57.3.2 Spacers

Spacers shall be provided to ensure that the rock bolt and the sheathing are centrally located within the hole and provided with a minimum of 30 mm of grout cover. Spacers shall also be provided to ensure that all sheaths if specified in the design are centrally located within the hole and provided with a minimum of 10 mm grout cover. Spacers shall be provided at both ends (within 300 mm from the ends) of bolt and at 750 mm intervals (maximum) along the bolt between the end spacers.

The spacers shall be fabricated from materials which have no deleterious effect on the rock bolt system. Spacers shall be manufactured to permit the free flow of grout.

57.3.3 Cement grout

Cement grout shall comply with Clause 6.3. In addition, it shall have a minimum characteristic strength of 40 MPa.

57.4 Construction

57.4.1 General

Rock bolts shall be installed in the locations and in accordance with the drawings.

57.4.2 Drilling

Holes for rock bolts shall be drilled to a minimum of 125 mm diameter in the directions and to the depths specified in the drawings.

The plant used to drill the holes into the rock face shall employ percussion drilling techniques and use air as the drill flushing medium. Water shall not be used as this can result in excess water pressures building up within the rock mass and cause instability of the rock slope.

57.4.3 Installation of rock bolts

The rock bolt shall be carefully positioned into the hole without damaging the encapsulating sheath or the grout tubes.

57.4.4 Grouting

57.4.4.1 Equipment

Grouting equipment shall include:

- a) a purpose-designed grout mixer of the continuous high speed type operating in the range of 1500 to 2000 rpm and producing grout free from lumps
- b) a holding tank fitted with an agitator
- c) a grout pump with a sustained outlet pressure of at least 400 kPa and fitted with a bypass back to the agitator tank, and
- d) a grout delivery line fitted with a gauge reading accurately to 1000 kPa.

57.4.4.2 Operations

Grouting of the rock bolts shall be performed in the presence of the Administrator. **Hold Point 20**

Grout shall be pumped into the hole through the grout tubes until grout is forced out of the top of the hole. The level of grout inside and outside the sheath shall be kept approximately equal to avoid damage to the sheath. The amount of grout pumped into the hole shall be recorded to determine if the hole is blocked or if there are voids in the rock mass. As the rock is likely to contain defects or voids, grout losses shall be expected. Each rock bolt shall be completely and continuously surrounded by a grout annulus.

57.5 Stressing active rock bolts

Before stressing the rock bolt, the grout shall have a minimum strength of 25 MPa and be at least five days of age.

The rock bolt shall be jacked to the Design Lock-Off Load specified in the drawings in five separate stages. The load to which the rock bolt shall be jacked in the five stages are 20%, 40%, 60%, 80%

and 100% of the Design Lock-Off Load. The load shall be held constant for five \ minutes at each loading stage and the deflection of the bolt head recorded at the start and completion of the specified loading period for each stage.

After the completion of loading at each stage, except for the last stage, the bolt load shall be relaxed to 20% of the Design Lock-Off Load before proceeding to the next stage of loading. The deflection of the bolt head shall be recorded each time the anchor load is relaxed to 20% of the Design Lock-Off Load. After completion of the loading stage to 100% of the Design Lock-Off Load, the bolt shall be engaged to the anchorage assembly to transfer the load in the bolt directly to the bolt head and bearing plate.

57.6 Load testing active rock bolt

The commencement of testing of active rock bolts shall be a Hold Point. **Hold Point 21**

All active rock bolts shall be tested.

The test procedure shall be:

- a) The load in the rock bolt shall be determined by carrying out a lift-off test. The lift-off test shall be undertaken using a jack and suitable accessories by lifting the bolt head a distance of 1 mm above the bearing plate. This step is considered satisfactory if the load measured is greater than or equal to 96% of the Design Lock-Off Load.
- b) If the load measured in subparagraph (a) is less than 96% of Design Lock-Off Load, then using a jack, the rock bolt shall be re-stressed to Design Lock-Off Load, plus an adjustment for lock-off losses. The lift-off test described in subparagraph (a) shall then be repeated. If the rock bolt load is still less than 96% of Design Lock-Off Load, a structural assessment shall be carried out to determine the future course of action for that rock bolt, and
- c) A second lift-off test shall be carried out three days after the first. The maximum load loss since the first lift-off test shall not exceed 12% of the Design Lock-Off Load.

The measured loads and displacements for all tests shall be recorded, plotted and compared with theoretical elastic deflections. A plot of these results for each rock bolt tested shall be delivered to the Administrator within three working days following the completion of the tests on that rock bolt.

After successful testing of the rock bolt, the void, if any, above the bonded length of the rock bolt to the underside of the anchor head shall be completely filled with grout.

58 Supplementary requirements

The supplementary requirements given in Clause 6 of Annexure MRTS03.1 shall apply.

59 Surveying requirements

All surveying requirements associated with the installation of new or relocated underground assets that include culverts, stormwater pipes, gullies and access chambers and retaining wall footings are to be fulfilled as prescribed in Clauses 6.1, 6.2, 6.3, 6.4 and 6.7 of the *TMR Surveying Standards, Part 2*.

60 Existing underground assets

In the event where any existing underground assets that may be fully or partly exposed during construction works, additional surveying information is required to be undertaken as prescribed in Clause 1.7, 6.7.7 and 6.7.8 of the *TMR Surveying Standards, Part 2*.

