

Technical Specification

**Transport and Main Roads Specifications
MRTS141 Microtunnelling and Pipe Jacking**

July 2017

Copyright



<http://creativecommons.org/licenses/by/3.0/au/>

© State of Queensland (Department of Transport and Main Roads) 2017

Feedback: Please send your feedback regarding this document to: tmr.techdocs@tmr.qld.gov.au

Contents

- 1 Introduction1**
- 2 Definition of terms1**
- 3 Referenced documents2**
- 4 Quality system requirements3**
 - 4.1 Hold Points, Witness Points and Milestones 3
 - 4.2 Construction procedures..... 4
- 5 Project Preliminaries4**
 - 5.1 Approvals 4
 - 5.2 Design requirements..... 4
 - 5.2.1 *Microtunnel alignment*6
 - 5.2.2 *Minimum depth below roads*6
 - 5.2.3 *Minimum distance from structures*7
 - 5.2.4 *Minimum distance from other utilities*7
 - 5.2.5 *Settlement and heave*7
 - 5.3 Dilapidation reports 7
 - 5.4 Construction procedures..... 8
 - 5.5 Construction risk assessment..... 8
- 6 Materials9**
 - 6.1 Jacking pipes 9
- 7 Construction.....9**
 - 7.1 General 9
 - 7.2 Personnel requirements..... 10
 - 7.3 Utility location..... 10
 - 7.4 Risk and Contingency Plans..... 10
 - 7.5 Overcut allowance 11
 - 7.6 Tunnelling equipment operation and steering 11
 - 7.7 Outer Annulus grouting 11
 - 7.8 Grouting of the carrier pipe annulus 12
 - 7.9 Special requirements for installation of precast pipe culvert components 12
 - 7.10 Instrumentation and monitoring 12
 - 7.11 Acid sulfate soils 13
 - 7.12 Remediation of disturbed areas..... 13
- 8 Tolerances 13**
- 9 As constructed records 14**

1 Introduction

This Technical Specification applies to the installation of pipelines, public utilities and plant underground structures using microtunnelling or pipe jacking methods. Microtunnelling and pipejacking works covered by this Technical Specification will generally use microtunnel excavation equipment described as Earth Pressure Balance Microtunnel Boring Machines, Slurry Microtunnel Boring Machines, Pilot Tube Microtunnel Machines, Vacuum Microtunnelling Machines or other similar equipment. Pipes will be jacked into place behind the microtunnelling machine using a jacking system located at the microtunnel launch pit.

Throughout the document the generic term “microtunnelling” shall be used to describe this work. This Technical Specification does not apply to large diameter tunnels using a segmental type lining.

This Technical Specification shall be read in conjunction with MRTS01 *Introduction to Technical Specifications*, MRTS50 *Specific Quality System Requirements*, TN163 *Third Party Utility Infrastructure Installation in State Controlled Roads Technical Guidelines* and other Technical Specifications as appropriate.

This Technical Specification forms part of the Transport and Main Roads Specifications Manual.

2 Definition of terms

The terms used in this Technical Specification shall be as defined in Clause 2 of MRTS01 *Introduction to Technical Specifications*. Additional terms used in this Technical Specification shall be as defined in Table 2.

Table 2 – Definition of terms

Term	Definition
carrier pipe	Permanent pipe, sometimes installed inside an enveloper pipe.
confined excavation	An excavation for a culvert, pipe or conduit trench or an excavation for a structure which requires the use of an excavator or similar machine fitted with a bucket. An excavation for any culvert, pipe or conduit trench or any structure shall not be classed as a confined excavation where the excavation is of sufficient size to allow the operation of a crawler tractor of Class 150C or larger, as determined in accordance with the provisions of Table 10.1 of AS 2868.
earth pressure balance microtunnelling (EPBM)	A closed tunnelling system with the potential to apply continuous pressure to the excavation face. Used in water charged soils or rock ground conditions. The excavated materials are removed by a screw conveyor into muck handling cars for removal from the microtunnel. Man access to the microtunnel is required, and is generally possible at diameters of 900 mm and above.
enveloper pipe / jacked pipe	Installed using trenchless methods to provide initial support to the excavated bore, prior to installation of the carrier pipe, or in some situations to provide the permanent ground support and be the permanent carrier pipe.
microtunnelling	Method for installing an underground conduit (microtunnel) to a high accuracy using a Microtunnel Boring Machine (MTBM) without disturbing the surface. The microtunnel lining is installed behind the MTBM using a pipe jacking operation.
natural ground surface	The ground surface which exists prior to any work being carried out under the Contract.

Term	Definition
pilot tube microtunnelling	An open tunnelling system used in dry soils or soft rock conditions. A pilot tube is established from the launch pit to the reception pit. The lining is then jacked into place as the hole is enlarged, following the alignment of the pilot tube.
pipe jacking	Method for installing an underground conduit (microtunnel) by jacking to high accuracy behind a Microtunnel Boring Machine (MTBM), or open-shield system without disturbing the surface.
sand	Natural or manufactured material with 100% passing 6.7 mm AS sieve and a low plasticity index.
slurry microtunnelling	A closed tunnelling system with the potential to apply continuous pressure to the excavation face. Used in water charged soils or rock ground conditions. The excavated materials are crushed and with addition of water and/or other materials a slurry is created that can be pumped out of the microtunnel.
spoil	Material surplus to the Contract requirements which shall be disposed of on or off the Site
topsoil	The top layer of existing soil on the Site which supports vegetation.
underground structures	Buried items including foundations, tanks, other structures and public utilities and plant.
unsuitable material	All material identified as unsuitable for use as a foundation for earthworks or structures and/or for use as fill or backfill material.
vacuum microtunnelling	An open tunnelling system. Excavation is carried out similar to Earth Pressure Balance or Slurry microtunnelling however spoil is removed using a vacuum system with or without the addition of water.

3 Referenced documents

Table 3 lists documents referenced in this Technical Specification.

Table 3 – Referenced documents

Reference	Title
AS 1554	<i>Structural Steel Welding</i>
AS 1726	<i>Geotechnical Investigations</i>
AS 2868	<i>Confined Spaces</i>
AS 4058	<i>Precast Concrete Pipes</i>
AS 4100	<i>Steel Structures</i>
MRTS01	<i>Introduction to Technical Specifications</i>
MRTS03	<i>Drainage, Retaining Structures and Protective Treatments</i>
MRTS04	<i>General Earthworks</i>
MRTS16	<i>General Requirements Landscape and Revegetation Works</i>
MRTS25	<i>Steel Reinforced Precast Concrete Pipes</i>
MRTS50	<i>Specific Quality System Requirements</i>
MRTS63	<i>Cast-In-Place Piles</i>
MRTS70	<i>Concrete</i>
MRTS78	<i>Fabrication of Structural Steelwork</i>

Reference	Title
MRTS91	<i>Conduits and Pits</i>
MUTCD	<i>Queensland Manual of Uniform Traffic Control Devices</i>
Standard Drawing 1178	<i>Diversion of Water – Diversion of Water from Roadway and Table Drains</i>
TN163	<i>Third Party Infrastructure Installation in State Controlled Roads Technical Guidelines</i>

4 Quality system requirements

4.1 Hold Points, Witness Points and Milestones

General requirements for Hold Points, Witness Points and Milestones are specified in Clause 5.2 of MRTS01 *Introduction to Technical Specifications*.

The Hold Points, Witness Points and Milestones applicable to this Technical Specification are summarised in Table 4.1.

Table 4.1 – Hold Points, Witness Points and Milestones

Clause	Hold Point	Witness Point	Milestone
4.2	1. Submission of construction procedures		Acceptance of construction procedures and design
5.1	2. Acceptance of Approvals to undertake proposed work		
5.2	3. Submission of design requirements		
5.2.4		1. Clearance to other utility services and structures	
5.2.5	4. Acceptance of settlement and heave monitoring procedure		
5.3	5. Pre-Construction Dilapidation Report		Post Construction Dilapidation Report
5.4			Acceptance of construction procedures and design
5.5	6. Acceptance of construction risk assessment		
7.2	7. Acceptance of nominated personnel		
7.3	8. Acceptance of existing utilities location		
7.7	9. Acceptance of annulus grouting procedure	2. Inspection of annulus grouting	

Clause	Hold Point	Witness Point	Milestone
7.8	10. Acceptance of carrier pipe grouting procedure		
8		3. Daily microtunnel as-built alignment records	
9			Submission of as-constructed records (10 days)

4.2 Construction procedures

The Contractor shall prepare documented procedures for all construction processes in accordance with Clause 5 of MRTS50 *Specific Quality System Requirements*.

Those construction procedures which are required to be submitted by the Contractor to the Administrator in accordance with Clause 5 of MRTS50 *Specific Quality System Requirements* include those listed in Table 4.2. **Hold Point 1**

Construction procedures shall be submitted at least 14 days prior to works commencing. No works shall proceed until approved by the Administrator. **Milestone**

Table 4.2 – Construction procedures

Clause	Procedure
5.4 and 7.6	Microtunnelling and pipe jacking equipment selection and operating procedure
5.4 and 7.6	Survey set out and alignment control (MTBM steering) procedure
5.2.5 and 7.10	Ground deformation monitoring procedure
5.5	Construction risk assessment
7.7 and 7.8	Annulus grouting procedure
7.12	Site remediation, landscaping and revegetation plan
6.1	Weld procedure (as applicable)

5 Project Preliminaries

5.1 Approvals

The works shall not commence until all relevant permits and approvals have been gained and signed off by the relevant authority. **Hold Point 2**

5.2 Design requirements

The design shall be carried out in accordance with this Technical Specification, TN163 *Third Party Utility Infrastructure Installation in State Controlled Roads* and the referenced documents shown in Table 3 by a person suitably qualified and experience required for the work being performed.

Prior to any approval being granted, or works commencing, the following aspects of the design (as a minimum) shall be submitted to the Administrator: **Hold Point 3**

- a) temporary works designs including but not limited to the pit / shaft excavation support, crane pads and access roads or laydown areas
- b) microtunnel alignment drawings, including identification of utility services and structures in proximity to the works
- c) impact assessment discussing the existing public utilities and plant and structures with potential to be affected by the works
- d) microtunnel temporary and permanent ground support design calculations and drawings
- e) anticipated ground deformation (settlement and heave) calculations
- f) calculations for thrust force reaction structures, jacking pipe thrust capacity and anticipated thrust loads
- g) jacking pipe design calculations, including joint design
- h) theoretical ground deformation calculations, including acceptable ground loss percentage and impacts on nearby structures including road pavements, bridges, culverts, road lighting assets, intelligent transport systems, road signs, and other third party utility assets
- i) drawings clearly identifying the impacts on natural water courses, table drains, drainage structures and overland flow paths
- j) instrumentation and monitoring plan
- k) details of any geotechnical data relied upon in the design of the works. As a minimum a geotechnical investigation must be undertaken in accordance with AS 1726. Boreholes or test pits must be to at least 1 m below the proposed invert level, and located at the entry and exit pits. Where crossing a dual carriage way road, or greater than 60 m then an additional borehole shall be drilled at approximately the mid-point of the microtunnel crossing. Additional holes shall be drilled if deemed necessary. The Administrator shall approve the extent of geotechnical testing carried out within a TMR corridor State-Controlled Road Corridor.
- l) details of potential impacts due to contaminated land, acid sulfate soils, fire ants, groundwater and any other environmental considerations specific to the site, and
- m) traffic management plan.

No standard design details, or historic as built information provided by Transport and Main Roads shall be relied up on in the design of the works unless approved by the Administrator.

The minimum design Standard Drawings to be submitted are described in Table 5.2.

All designs are to be certified by a Registered Professional Engineer of Queensland (RPEQ) having suitable experience in the field of microtunnelling.

Table 5.2 – Design drawing requirements

Drawing Description	Drawing Detail	Minimum Content / Requirements
Microtunnel alignment and profile	Plan and elevation	Clearly identify dimensions including microtunnel length and depth of the microtunnel below the existing surface, and proximity to existing public utilities and plant. Positions of investigation boreholes shall be indicated including strata cross sections if applicable.
Microtunnel general arrangement	Cross sections	Clearly identify dimensions including, excavation diameter, outer / inner diameter of the enveloper pipe (if any) and outer / inner diameter of the carrier pipe.
Shaft / pit construction	Plan and elevations (cross sections if appropriate)	Include all structural details and staging plans if required.
Shaft / pit layout	Plan and elevation	Include details of access/egress, groundwater control, rainfall / runoff management and existing public utilities and plant.
Site layout(s)	Plan	Include all existing structures, roads, public utilities and plant, paths and vegetation. Identify any vegetation to be removed, and public utilities and plant or existing structures to be removed or relocated.

5.2.1 Microtunnel alignment

The microtunnel shall pass under roads in a straight line and within 5° of perpendicular to the road centreline, unless otherwise approved by the Administrator.

5.2.2 Minimum depth below roads

The minimum depth of cover for microtunnels within a state road corridor shall be in accordance with TN163 *Third Party Utility Infrastructure Installation in State Controlled Roads Technical Guidelines*. Refer to Figure 5.2.2(a) and Figure 5.2.2(b) below for an indication of cover requirements.

Figure 5.2.2(a) – Minimum depth below single carriageway

Figure 5.2.2(b) – Minimum depth below dual carriageway



5.2.3 Minimum distance from structures

Microtunnels shall be located according to the requirements of TN163 *Third Party Utility Infrastructure Installation in State Controlled Roads Technical Guidelines*.

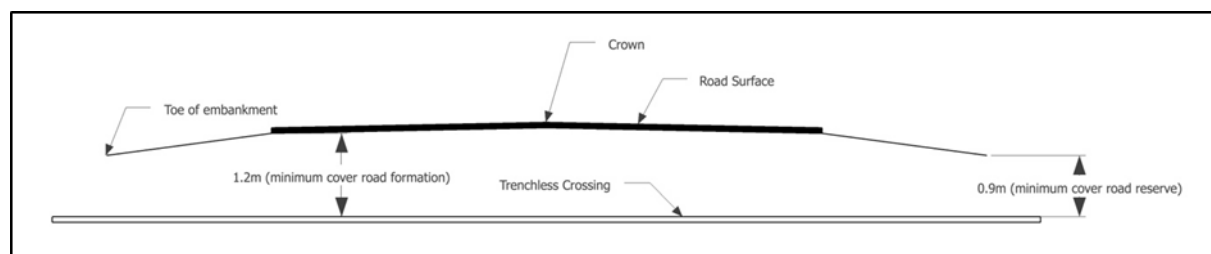
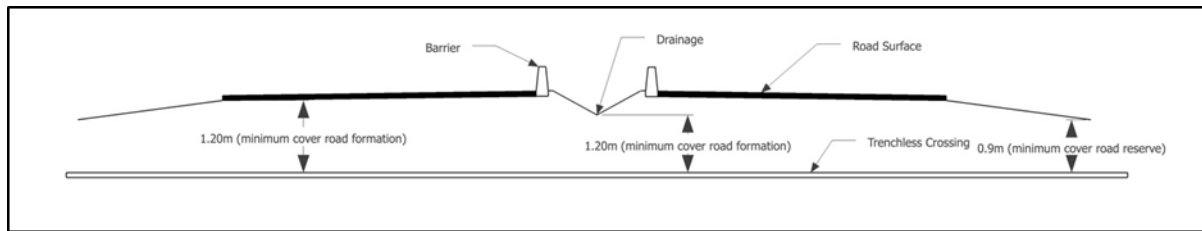
5.2.4 Minimum distance from other utilities

The distance between the microtunnel and any existing utility service shall be as approved by the relevant utility owner. This approval shall be provided to the Administrator prior to commencing works.

Witness Point 1

5.2.5 Settlement and heave

Permissible deformations will depend on the sensitivity of the Transport and Main Roads asset, and will be subject to approval by the Administrator on a case by case basis. The total ground surface and differential settlement limits shall be agreed upon by the Administrator before commencement of the works. The predicted settlement contours due to the microtunnel must be presented in a graphical form. The Contractor shall submit a ground deformation monitoring procedure to the Administrator prior to commencing works. **Hold Point 4**

5.3 Dilapidation reports

The Contractor is responsible for all pre-construction and post-construction property and infrastructure assessments. Pre-construction assessments shall be submitted to the Administrator for review and acceptance at least 14 days prior to works commencing. **Hold Point 5** Post-construction assessments shall be submitted to the Administrator for review. **Milestone** These assessments shall be a means of determining whether, and to what extent, damage has resulted from the Contractor's operations during the works. Any damage identified shall be reinstated on a 'like for like' basis at the Contractors expense.

As a minimum the dilapidation reports shall capture:

- a) all work sites and any surrounding area likely to be impacted by the construction activities, including heavy vehicle traffic associated with the works
- b) a minimum distance of three times the depth of any shaft measured radially from its perimeter
- c) a minimum distance of two times the depth to invert level each side of the centreline of any microtunnel
- d) any area within the settlement trough or zone of influence as defined by the Contractors prediction of ground settlement
- e) the report must capture the condition of all aspects of the natural and built environment within the nominated areas, including but not limited to building interior and exterior, public utilities and plant, roadways and landscaping, and

- f) The condition of any departmental structure shall be recorded according to a Level 2 Bridge Condition Inspection as defined in the *Structures Inspection Manual*.

5.4 Construction procedures

Construction procedures shall be submitted to the Administrator for approval at least 14 days prior to any planned works. **Milestone** The construction procedures must document at least the following critical aspects of the works as relevant to the specific project:

- a) site establishment (provision of access and working platform if required)
- b) equipment selection and operating methods
- c) equipment operation and removal of spoil
- d) confined space entry and microtunnel access (if required)
- e) welding of the pipes (enveloper and/or carrier pipe)
- f) lifting plans
- g) monitoring of ground deformations (settlement / heave) and ground loss
- h) monitoring of as built alignment and jacking pipe deflections (see Clause 7.7)
- i) monitoring of jacking loads
- j) survey methodology including design and operation of a steering system to achieve the design microtunnel alignment
- k) use of drilling fluids, lubricants, cementitious grouts or other consumables, including relevant environmental and disposal information
- l) inner and outer annulus grouting procedures
- m) demobilisation of equipment, and
- n) landscaping, revegetation and reinstatement of the site area following completion of the works.

The Contractor must also provide a risk and contingency plan to address the risk of failure of any part of the works, and have appropriate materials, equipment and plans available to mitigate against the risks identified.

5.5 Construction risk assessment

The Contractor shall provide the Administrator with a comprehensive risk assessment addressing the entire scope of work proposed. **Hold Point 6** This risk assessment must at least address the following activities:

- a) Site establishment, access, and traffic control
- b) excavation of trenches, pits, and shafts
- c) design and installation of shoring or other temporary ground support
- d) operation of the tunnelling equipment
- e) work at heights and work in confined spaces
- f) potential for damage to infrastructure, including structures and public utilities and plant

- g) immediate and long term settlement and heave resulting from the works
- h) flooding and alteration of existing drainage paths
- i) interaction with the public, and
- j) potential damage to the environment including areas of cultural significance.

6 Materials

6.1 Jacking pipes

Jacking pipes used shall comply with the requirements of the standards listed in Table 6.1.

Pipes of other materials may be subsequently pulled or pushed into the jacked pipe, to meet the specific requirements of the third party asset owner.

Table 6.1 - Jacking pipe material standards

Pipe material type	Standard
Concrete	AS4058, MRTS25
Glass reinforced polymer (GRP)	DIN 16869 and DIN 19565
Polymer concrete	DIN 54815-1 and DIN EN14636-1
Steel	AS4100
Vitrified Clay	EN295

Where a steel enveloper pipe is used the Contractor shall provide weld procedures to the Administrator as required by MRTS78.

For clarity it should be understood that in some cases the jacked pipe will form the permanent product pipe (carrier pipe) e.g. culverts stormwater or gravity sewer pipes.

However for pressure applications the jacked pipe shall become an enveloper pipe that will later have the permanent product pipe (carrier pipe) pushed or pulled inside of it. This is to provide added protection to the TMR asset in the event of failure of the pressurised utility service. Refer to the departmental Technical Note 163 *Third Party Infrastructure Installation in State Controlled Roads Technical Guidelines* for further details regarding when an enveloper pipe is required.

7 Construction

7.1 General

A site supervisor who has experience with and is knowledgeable in the use of the equipment and procedures proposed for the works must be present at the work site at all times whilst tunnelling is underway.

Protection of the public and work site shall be established with temporary fencing and traffic control devices in accordance with the Queensland *Manual of Uniform Traffic Control Devices* (MUTCD).

All earthworks including site preparation and backfill of excavations shall comply with the requirements of MRTS04 *General Earthworks*. Topsoil shall be stockpiled onsite for reuse.

All excavated material is to be disposed of in accordance with MRTS04 and the relevant environmental requirements. Microtunnel spoil shall be deemed unsuitable material unless approved for reuse by a suitably experienced geotechnical engineer.

All temporary works are to be demolished and removed from the site following completion of the works, unless otherwise approved by the Administrator.

All concrete shall be in accordance with MRTS70 *Concrete*, except as otherwise approved by the Administrator.

The Contractor may seek dispensation from MRTS70 for concrete used in temporary works subject to approval by the Administrator.

7.2 Personnel requirements

The Contractor must ensure appropriately trained and experienced personnel are engaged for the delivery of the works. All Contractors must hold current licences and qualifications where required. Details of key personal experience and copies of relevant licenses and qualifications shall be provided to the Administrator's representative for approval before the works commence. **Hold Point 7**

7.3 Utility location

Prior to commencing any excavation, dial-before-you-dig (DBYD) searches shall be carried out to locate any underground utilities (i.e. gas, sewer, water, fuel, electrical, etc.,) in the work area. Once the utilities have been located the Contractor shall engage a licensed service locator to identify the exact location of the utilities by vacuum or hand excavation, when possible, in order to determine the actual location and path of any underground utilities which might be within the microtunnel path. The Contractor shall not commence excavation or microtunnelling operations until the location of all underground utilities within the work area have been verified and the verification details are to be submitted to the Administrator. **Hold Point 8**

7.4 Risk and Contingency Plans

The Contractor is to prepare and implement an approved contingency plan dealing with the key project or microtunnelling risks identified. As a minimum the Contractor is to have documented procedures complete with equipment and materials on standby to mitigate against the following microtunnelling risks:

- a) shaft / pit collapse
- b) tunnel collapse
- c) shaft / pit flooding
- d) tunnel flooding
- e) hydrocarbon spill
- f) major MTBM mechanical failure
- g) settlement or heave scenarios
- h) encountering an unforeseen obstruction
- i) safety incidents

- j) high water inflows at the face of MTBM which prevents access to the pressure chamber for cutter inspection and replacement
- k) higher jacking forces than expected, and
- l) Any other environmental incidents not mentioned above.

7.5 Overcut allowance

The external diameter of the tunnelling machine shall produce a minimum overcut to provide the required clearance (annulus) between the outside of the jacking pipe and excavated ground. The overcut shall not exceed 30 mm, or more than 2% of the pipes outside diameter, whichever is lesser.

7.6 Tunnelling equipment operation and steering

All aspects of the tunnelling operation shall be documented in a selection and operating procedure. This procedure shall address at least a selection of tunnelling equipment operating parameters (thrust, rotation speed, etc), control of face pressure, ground loss monitoring, spoil removal and steering.

Steering of the tunnelling machine shall be constantly monitored during operations to ensure the design alignment is achieved.

The Contractor shall ensure a suitable guidance system is used, which can include one or a combination of the following, laser target, theodolite, or gyroscope.

For any microtunnel drive greater than 100 m in length a survey audit shall be undertaken mid-way through the works. This should address accuracy of the control points used for microtunnel guidance, and where possible the excavated microtunnel alignment as built to confirm the specified tolerances are being achieved.

7.7 Outer Annulus grouting

Outer annulus grouting is undertaken to ensure a uniform contact between the enveloper pipe and the excavated ground and to prevent the surrounding ground settling over time. Outer annulus grouting shall be undertaken unless otherwise approved by the Administrator. The Contractor shall provide an annulus grouting procedure to the Administrator for approval prior to commencing any tunnelling works. **Hold Point 9**

Grout used shall obtain a minimum strength of 1MPa at 48 hrs. Previous performance of the grout mix design shall be demonstrated to the Administrator before use. The outer annulus grout is to be pumped until one of the following conditions is met:

- The pumped grout volume has equalled the theoretical annulus volume between grout ports (15 m), allowing for any over excavation identified during microtunnel advance.
- The pumped grout pressure exceeds the theoretical hydrostatic ground pressure plus 0.25 bar.
- The pumped grout is visible at the next inbye open crown (or upper) grout port, or at the opposite end of the microtunnel for short tunnels grouted from one end only.

A secondary checking process will be undertaken to prove that grout surrounds the pipe where man access is available inside the microtunnel. A selection of crown (or upper) grout ports are opened and inspected for grout with a screw driver. This would ordinarily be performed in the presence of the Administrator. **Witness Point 2**

7.8 Grouting of the carrier pipe annulus

Figure 3 below demonstrates the void between the carrier pipe and enveloper pipe that is the subject of this section.

Figure 3 - Carrier Pipe Annulus

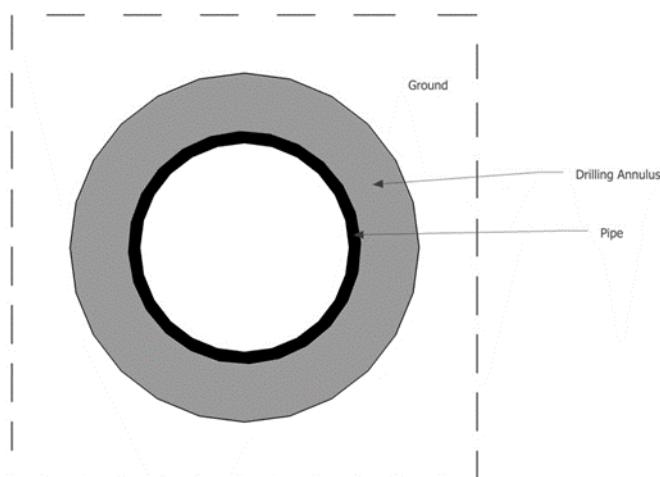

The space between the enveloper pipe and carrier pipe shall be completely filled with a cementitious grout unless otherwise approved by the Administrator. **Hold Point 10** Approval to not grout this space will only be approved if all of the following conditions are met:

- a) the enveloper pipe is designed to provide permanent ground support for at least 50 years
- b) the enveloper pipe has a grade of at least 1:200 to facilitate natural draining of any water
- c) the enveloper pipe does not alter the existing flow path of water
- d) the enveloper pipe is either suitably sealed at each end to prevent unauthorised access, or is filled with sand, and
- e) failure of the carrier pipe will not cause any damage to the roadway or adjacent embankment.

7.9 Special requirements for installation of precast pipe culvert components

MRTS04 specifies additional requirements for the installation of precast pipe culvert components using jacking methods. The Contractor shall ensure that these requirements are met.

7.10 Instrumentation and monitoring

Geotechnical instrumentation and monitoring shall be undertaken where infrastructure assets could be affected by the proposed microtunnel works. The proposed monitoring regime, including the frequency of monitoring shall be defined in the design documentation submitted to the Administrator. This shall be submitted for review to the Administrator before the commencement of the Works. Generally, survey monitoring of ground deformations is considered acceptable, and this monitoring over carriageways shall consider:

- a) survey markers at the edges of the shoulder points, edges of the pavements, each line marking, and otherwise at 3 m intervals along the microtunnel centreline

- b) a baseline survey must be performed prior to commencement of any tunnelling operations. During tunnelling activities a survey shall be performed daily, until the zone of active excavation has passed and no further movement is detected, and
- c) baseline measurements must be forwarded to the Administrator and accepted before commencement of any works on site.

Reporting of ground deformations to the Administrator shall be in accordance with the agreed instrumentation and monitoring plan. The monitoring plan shall specify the trigger levels, trigger level criteria, responsible persons and actions required. A notification trigger criteria shall be defined, typically being as follows:

- a) no action – if deformations are less than 80% of the agreed values. Excavation can continue
- b) action – if deformations are greater than 80% but less than 100% of the agreed values then the Administrator shall be notified within 24 hours. The frequency of monitoring shall be increased, and
- c) alarm – if the deformations are greater than the agreed values, the Administrator and key personnel shall be notified immediately and the excavation works shall be stopped unless a mitigation strategy is agreed upon with the Administrator.

7.11 Acid sulfate soils

Prior to undertaking any works onsite an investigation to identify the possible presence of acid sulfate soils shall be undertaken according to MRTS04 *General Earthworks*. Where acid sulfate soils are identified the requirements detailed in MRTS04 *General Earthworks* shall be followed.

7.12 Remediation of disturbed areas

Any area disturbed by the works shall be replaced/reinstated on a 'like for like' basis in accordance with the relevant MRTS Specification. These include MRTS04 *General Earthworks*, MRTS03 *Drainage, Retaining Structures and Protective Treatments*, MRTS16 *General Requirements Landscape and Revegetation Works*.

All disturbed areas must be backfilled, or excavated to return the area to the level of the natural ground surface that was present prior to the works being undertaken, unless approved otherwise and shown on the Standard Drawings.

All excess spoil shall be removed from site upon completion of the works and disposed of in accordance with the relevant regulations.

8 Tolerances

The location of the microtunnel shall be checked and recorded at the start and end of each installed pipe segment (at least twice per pipe segment) and the position recorded against the design grade on the tunnelling shift report. This information shall be provided to the Administrator daily unless agreed otherwise. **Witness Point 3**

The final microtunnel alignment shall conform to the tolerances set out in Table 8, unless nominated differently on the Standard Drawings and agreed with the Administrator.

Table 8 - Installation tolerances

Alignment Detail	Limits / Tolerance
Horizontal	± 50 mm
Microtunnel grade	± 0.25%
Vertical	± 30 mm

These tolerances are for the enveloper / jacked pipe only. Third party utility owners may require limits / tolerances more stringent than required by Transport and Main Roads in this case these shall take precedence. Transport and Main Roads have no requirements regarding the installation limits / tolerances of a carrier pipe installed inside an enveloper pipe.

9 As constructed records

The Contractor shall provide the following as constructed records to the Administrator in relation to each microtunnel, no later than 10 days after completion of the Works. **Milestone**

- a) as built survey record of the completed microtunnel, including steering records documented during the installation process
- b) grouting records (internal and external annulus)
- c) ground deformation monitoring records, including final measurements taken once no further movement is recorded, and
- d) final dilapidation report capturing all areas disturbed by the works, providing photographic evidence that all required remediation has been completed.

