

UNGROUTED ROCK SHOULDER IN FILL

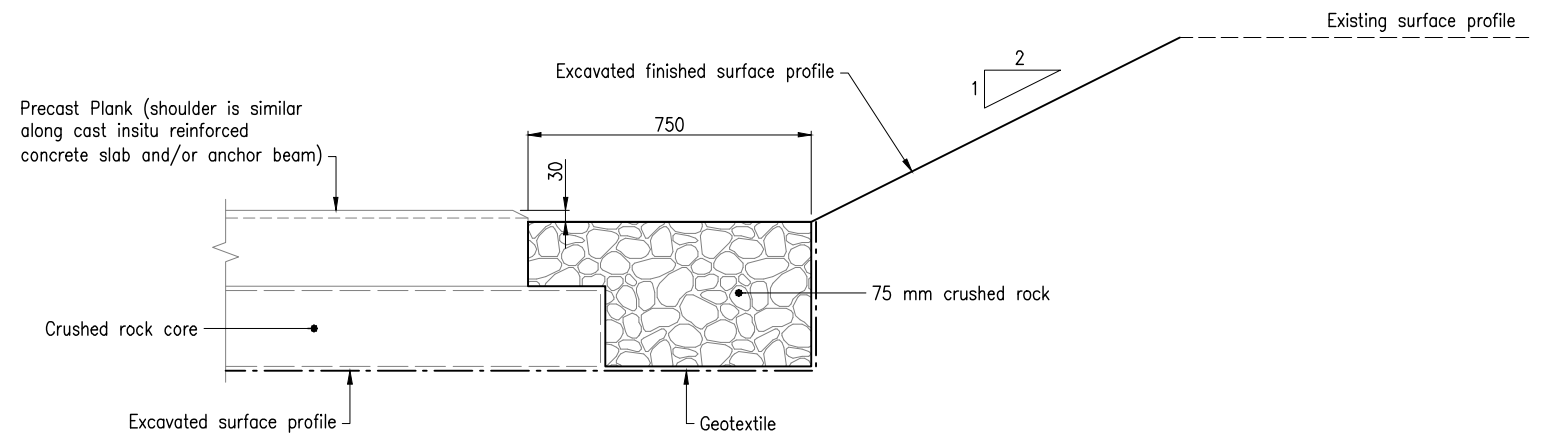

UNGROUTED ROCK SHOULDER IN CUT

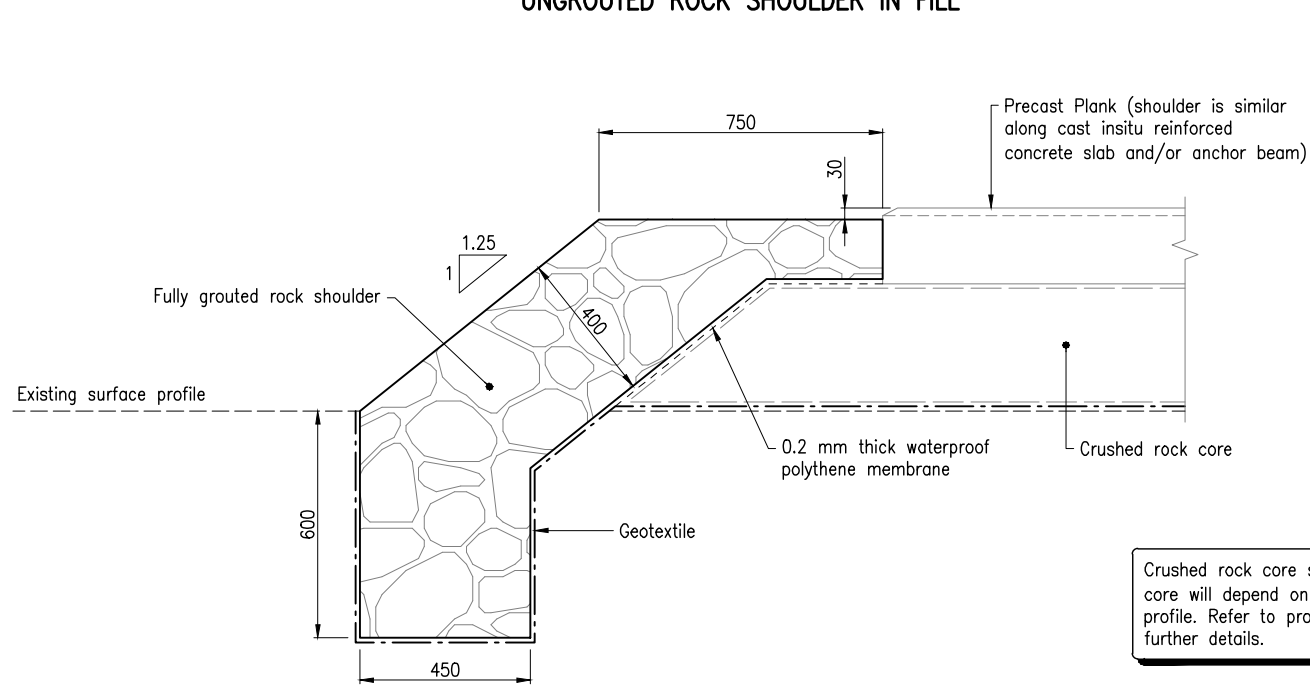

FULLY GROUTED ROCK SHOULDER IN FILL

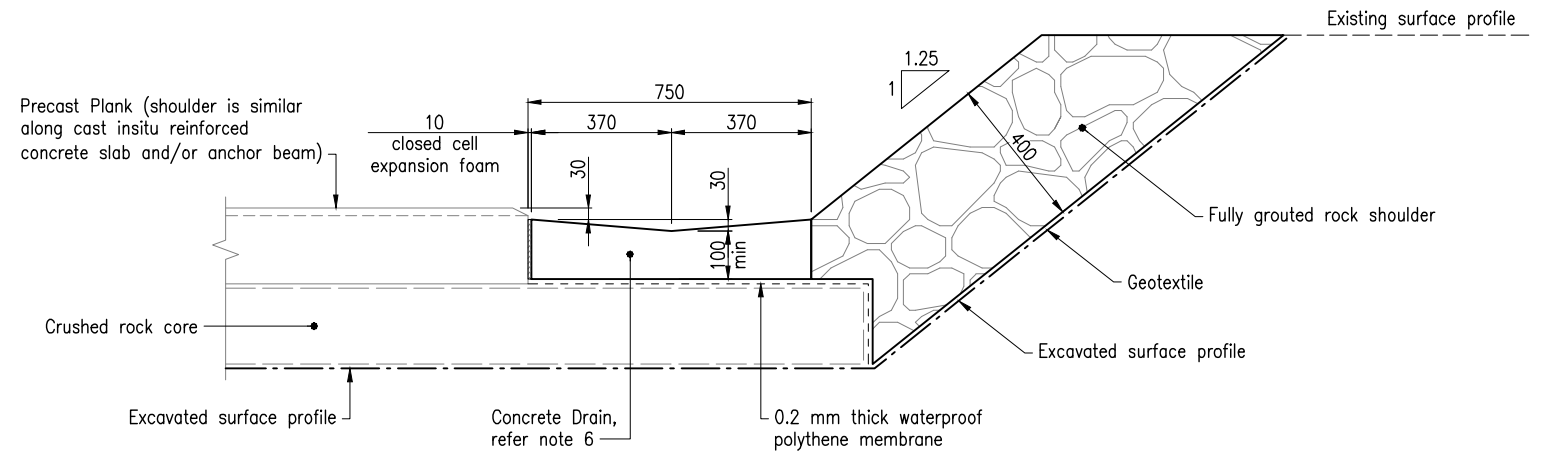

FULLY GROUTED ROCK SHOULDER IN CUT

Crushed rock core shown indicatively only. Depth of core will depend on existing/excavated surface profile. Refer to project specific design drawings for further details.

NOTES:

- CONSTRUCTION OF BOAT RAMP shall be in accordance with MRTS300.
- ROCK for the fully grouted shoulders shall be unweathered, clean, hard and durable graded 150 to 200 mm with essentially flat faces.
Grout shall be 20 MPa cement mortar made from a 1:3 GP cement/sand mixture with sufficient water added to give it a plastic like texture that will retain its shape and not flow like a liquid.
- FOOTINGS: The excavation for footings shall be to the minimum design depth and thickness and fully lined with geotextile. Sufficient extra geotextile shall be allowed so that full separation of footing and existing base material is retained during consolidation.
The footings shall be full thickness grouted rock to ensure that structural integrity of the core and shoulders is retained if the existing base materials erode.
Footings may alternatively be constructed using S25/20 mass concrete.
- SHOULDER BATTERS CONSTRUCTION: The shoulder and shoulder batter shall be constructed by placing alternate layers of grout and rock so that the grout shall extend through the full design thickness of the shoulders. Rocks shall be placed to form irregular joints and be interlocked with smaller sized rock so that there are not any large voids and individual rocks cannot be easily dislodged.
Shoulders which are constructed by placing rock and then grouting or shotcreting only the outer surface shall be rejected.
The shoulder batter shall be fully supported and not extend beyond the edge of the footing.
- GROUTED ROCK SURFACE FINISH: Exposed surfaces shall have a minimum of 80% of exposed rock with a close faced maximum mortar setback of 10. Excess cement mortar coating shall be removed.
The finished surface shall have a generally flat, even and neat appearance, and will not have any sharp or angular points which will be hazardous to ramp users.
- CONCRETE DRAIN: Concrete shall be S50/20, exposure classification C and cured in accordance with MRTS70.
Tooled contraction joints to be provided at 2 m nominal spacings by forming grooves 40 deep and not more than 6 mm wide in exposed surfaces of the concrete. Grooves shall be normal to the top surface and square to the drain alignment. Joint locations shall match with adjacent precast plank gaps.
Trafficable surface shall have a medium broom finish at 90° to the boat ramp control line.
- For geotextile, geogrid, 75 mm crushed rock grading and earthworks details refer Standard Drawing 4021.
- DIMENSIONS are in millimetres unless shown otherwise.

ASSOCIATED DEPARTMENTAL DOCUMENTS:

Standard Drawings
Specifications



REFERENCED DOCUMENTS:

Departmental Standard Drawings:

4020 Boat Ramp Construction – Precast Plank Installation and Anchor Beam Types 1 and 2
4021 Boat Ramp Construction – Earthworks and Crushed Rock Core Details

Departmental Specifications:

MRTS70 Concrete
MRTS300 Boat Ramps

Department of Transport and Main Roads		  <small>© The State of Queensland (Department of Transport and Main Roads) 2015 http://creativecommons.org/licenses/by/3.0/au</small>
BOAT RAMP		
BOAT RAMP CONSTRUCTION – FULLY GROUTED SHOULDERS AND UNGROUTED SHOULDERS		A3 Not to Scale Standard Drawing No 4022 Date 10/15
A	B	