

TYPICAL PLAN  
INLET ON GRADE

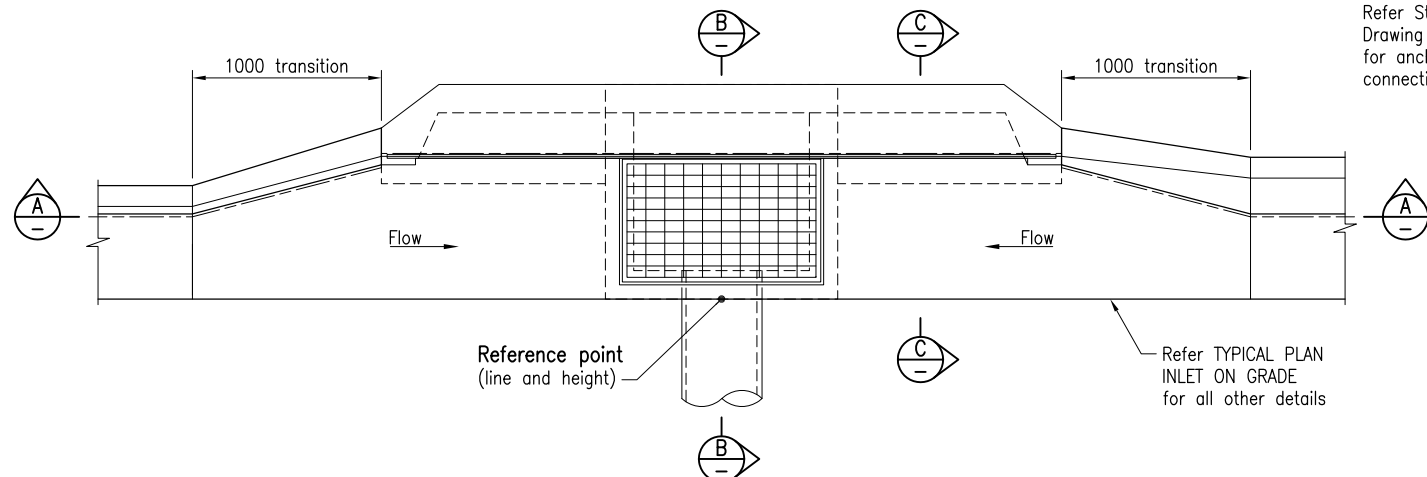

TYPICAL PLAN  
INLET IN SAG

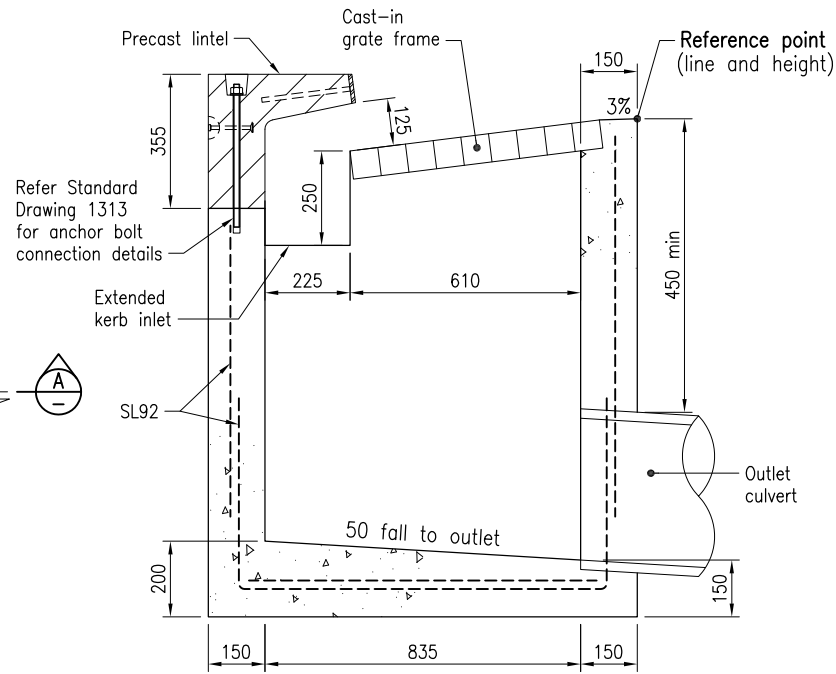

SECTION B

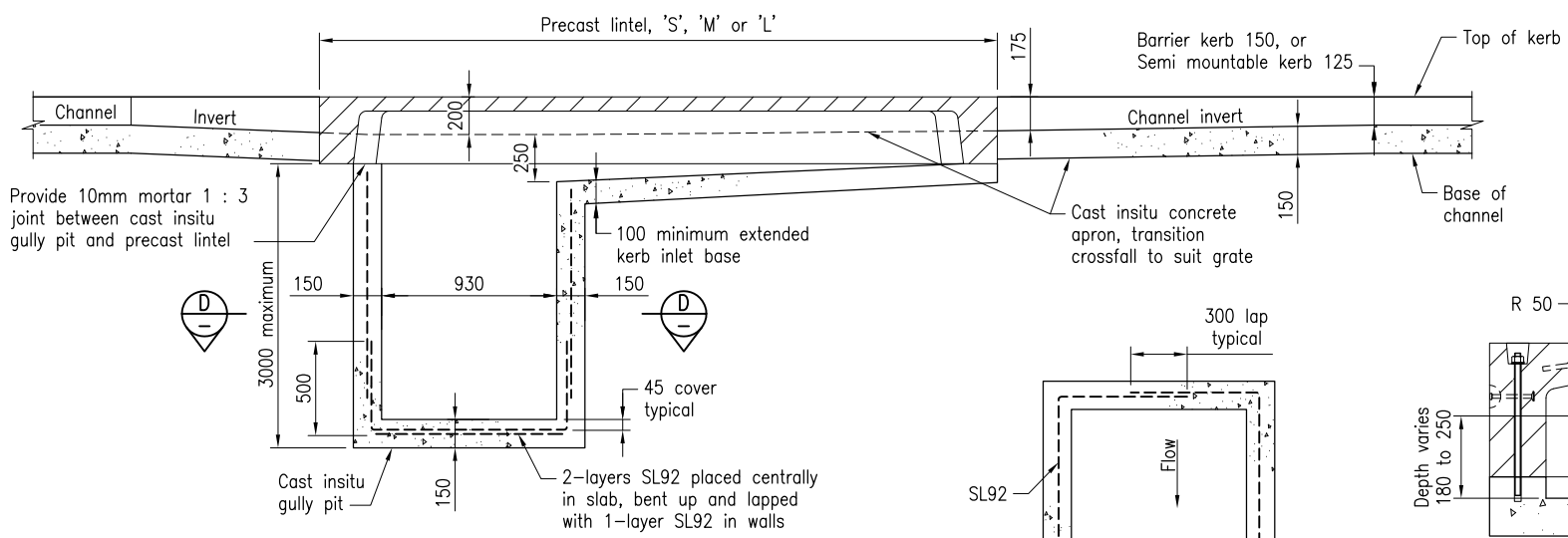

SECTION A  
ALONG CHANNEL INVERT,  
INLET ON GRADE SHOWN,  
INLET IN SAG SIMILAR

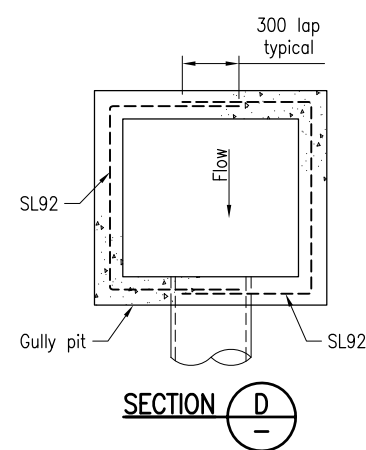

SECTION D

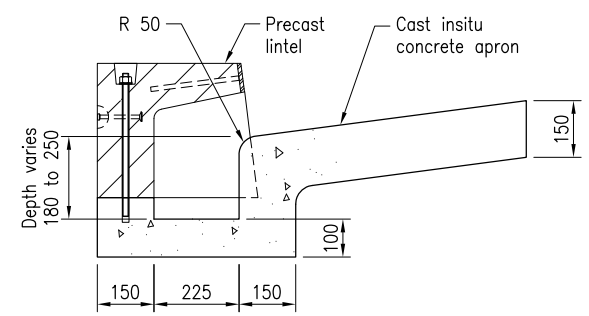

SECTION C

**NOTES:**



- SCOPE: This Standard Drawing provides details of cast insitu roadway type gully with channel lip in line, and using precast lintel as per Standard Drawing 1313. This standard drawing shall be used for cast insitu gully pit depth of maximum 3000. Pit sizes greater than those shown on this drawing shall be a project specific design. Constructability and accessibility of deeper pits shall be considered in the design. Refer Note 9 for additional design requirements for pits deeper than 5000. Refer Standard Drawing 1312 for cast insitu roadway type gully with kerb in line. Refer Standard Drawing 1313 for precast lintel.
- CONCRETE ROADWAY TYPE GULLIES shall be in accordance with MRTS03.
- DESIGN LIFE: 50 years
- DESIGN OF CONCRETE COMPONENTS for all pit sizes and depths:
  - Traffic loads and traffic load surcharge shall be in accordance with AS 5100.
  - Load factors and load combinations shall be in accordance with AS 5100.
  - Structural design shall be in accordance with AS 3600.
- CONCRETE shall be in accordance with MRTS70. Concrete pit S32/20. Concrete channel N32/10. Exposure classification B1 to AS 3600. Minimum cover to reinforcement shall be 45 unless shown otherwise. All exposed edges shall have 19 x 19 chamfers unless shown otherwise.
- REINFORCING STEEL shall be in accordance with Standard Drawing 1044. Reinforcing steel shall be in accordance with MRTS71 and AS/NZS 4671. Mesh Grade D500L. All reinforcing steel shall be ACRS certified.
- GRATES AND FRAMES shall be Class D to AS 3996. Bicycle safety testing of grates and covers shall be in accordance with AS 3996. Hinged grates are to be provided with a positive mechanical retainer to secure them firmly in place when in the open position. Double hinge system shall be provided for grates designed to accept flow from one direction. Approved grates and frames shall be used.
- SUBSOIL DRAIN OUTLETS: Where a subsoil drain is discharged into a gully pit, the outlet of the subsoil drain shall be located above the level of the invert of the stormwater pipes/culverts unless otherwise approved by the Administrator. The subsoil drain outlets shall be provided with pest-proof flaps.
- DESIGN REQUIREMENTS for pits deeper than 5000:
  - Design life for pits 100 years; other concrete components 50 years
  - Minimum exposure classification B2 to AS 5100
  - Minimum concrete strength S40/20 for pit; and N32/10 for other
  - Cover to reinforcement to AS 5100
 Refer Note 4 for concrete design requirements.
- DIMENSIONS are in millimetres unless shown otherwise.

ASSOCIATED DEPARTMENTAL DOCUMENTS:

- Design Criteria for Bridges and Other Structures
- Road Drainage Manual

REFERENCED DOCUMENTS:

- Departmental Standard Drawings:
  - 1033 Kerb and Channel – Kerbs, Channels and Ramped Vehicular Crossing
  - 1044 Reinforcing Steel – Lap Lengths
  - 1312 Concrete Gully – Roadway Type Kerb in Line
  - 1313 Concrete Gully – Precast Lintel Details
- Departmental Specifications:
  - MRTS03 Drainage, Retaining Structures and Protective Treatments
  - MRTS70 Concrete
  - MRTS71 Reinforcing Steel
  - MRTS72 Manufacture of Precast Concrete Elements

Department of Transport and Main Roads		 <small>© The State of Queensland (Department of Transport and Main Roads) 2017 http://creativecommons.org/licenses/by/3.0/au</small>	
CONCRETE GULLY			
ROADWAY TYPE CHANNEL LIP IN LINE		A3	Standard Drawing No
		Not to Scale	1311
			Date 4/17
A	B	C	