

TABLE 1 – SETOUT DIMENSIONS

	TYPE A Residential (Car/Service Vehicle)	TYPE B Commercial (Single Unit Truck/Bus)	TYPE C Special (Articulated Vehicles)	TYPE D Special (Road Trains)
R1	10m	10m	15m	20m
R2	10m	10m	12m	12m
D	2m	2m	3m	3m
X	3m	5m	4m	5m
S	12m	15m	22m	30m**
G	4–6m ∅	4–6m ∅	6m	6m
∅ 6m Minimum width for two-way two-lane access.				

LEGEND

- Pavement Type 1 – Bitumen surfacing, 2 coat bitumen seal. Pavement depth and type to match existing or proposed through road pavement. Refer to Table 2 for minimum depths.
- Pavement Type 2 – Gravel, unbound pavement. Refer to Table 2 for depths. Access may be required to be sealed for up to 10m width from edge line (to minimise gravel on through road) to be determined by the RPEQ.
- * Maintain existing shoulder crossfall and superelevation.
- ** Length 'S' to property boundary by TMR. Where length 'S' is greater than the road reserve boundary, then fencing and grid/gate shall be recessed at the cost of owner from property boundary to ensure vehicle does not impede through lane.
- *** RCBC (min. size 600x300) can be used instead of RCP, or invert option where table drain is of insufficient depth for a culvert.
- Denotes Road Edge Guide Post
- The Filled in portion denotes a red reflector and the open portion a white reflector.

TABLE 2 – MINIMUM PAVEMENT DETAILS AND DEPTH

	TYPE A Residential (Car/Service Vehicle)	TYPE B Commercial (Single Unit Truck/Bus)	TYPE C & D Special (Articulated Vehicles)
Sealed Pavement Base Course	150mm(Min.) Type 2.2 or match existing	200mm(Min.) Type 2.2 or match existing	280mm(Min.) Type 2.2 or match existing
Unsealed Pavement Base Course	150mm(Min.) Type 2.4 or match existing	200mm(Min.) Type 2.4 or match existing	#

- NOTE:
- Pavement to be sealed if through road is sealed to minimum of width 'D' of Table 1.
 - Where access is located on curves, intersections or is Type C, or excessive screwing motion will occur, pavement seal to extend to property boundary at the owner's cost to the engineer's/designer's discretion.
- # Bitumen sealed pavement only.
- ◆ Type 3.1 or 4.3 or match existing is permissible if Type 2.2/2.4 is unable to be used.

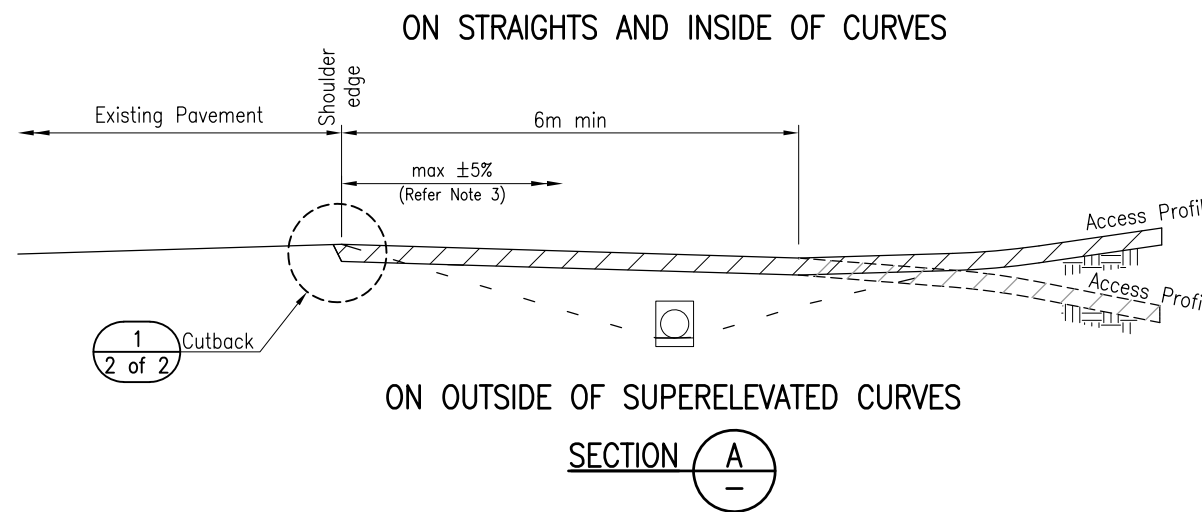
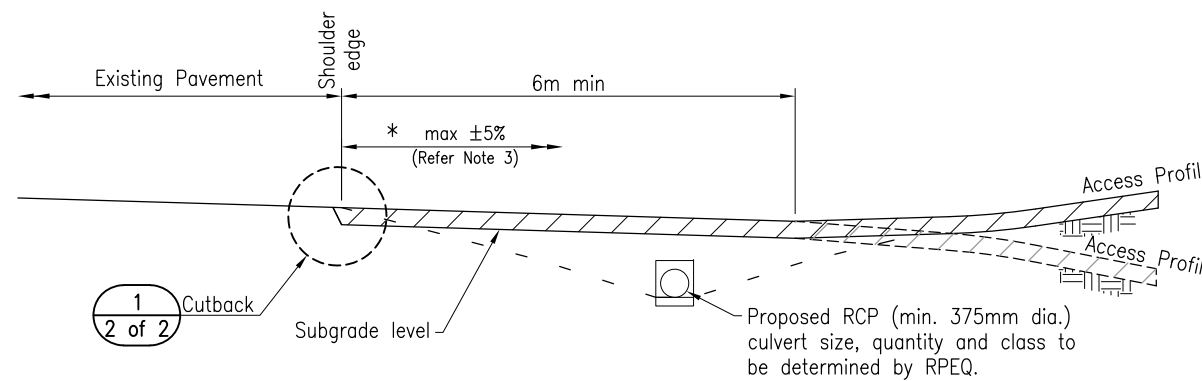

NOTES:

- Details shown on this drawing are the minimum layout requirements for a private rural property access. For additional requirements and other design considerations refer to Sections 7.2.1 and 7.2.3 of the AGRD-4 (2009).
- For sight distance requirements refer to Section 3.4 of the RPDM (2nd Edition) Volume 3 Supplement to AGRD-4A, and Section 3 of the AGRD-4A (2010).
- Vertical clearance checks to be carried out for proposed vehicle in accordance with AS 2890.2 – Parking Facilities Off-Street Commercial Vehicle Facilities.
- RPEQ or designer to conduct traffic impact assessment to determine if turning treatments are required. Urban right-turn treatments maybe appropriate, refer to Section 7.5 of the AGRD-4A (2010) for pavement widening requirements. Pavement type to match existing or minimums specified in Table 2 of this drawing.
- This drawing is to be read in conjunction with Drawing 2 of 2.
- All dimensions in metres and are minimum unless specified.

REFERENCED DOCUMENTS:

- Departmental Standard Drawings:
- 1243 Precast Culvert Headwalls – Headwall Connections for Culverts
 - 1305 Pipe Culverts - Headwall and Apron for Pipe Diameter 375 to 675
 - 1359 Culverts - Installation, Bedding and Filling/Backfilling Against/Over Culverts
- Departmental Documents:
- RPDM Road Planning and Design Manual (2nd Edition)
 - MRTS03 Drainage, Retaining Structures and Protective Treatment
- Austrroads Guide to Road Design:
- AGRD-4 (2009) Part 4: Intersections and Crossings – General (2009)
 - AGRD-4A (2010) Part 4A: Unsignalised and Signalised Intersections (2010)
 - AGRD-5B (2013) Part 5B: Drainage – Open Channels, Culverts and Floodways (2013)

Department of Transport and Main Roads			
PROPERTY ACCESS		© The State of Queensland (Department of Transport and Main Roads) 2020 http://creativecommons.org/licenses/by/3.0/au	
RURAL PROPERTY ACCESS DRAWING 1 OF 2		A3 Not to Scale	Standard Drawing No 1807 Date 07/2020

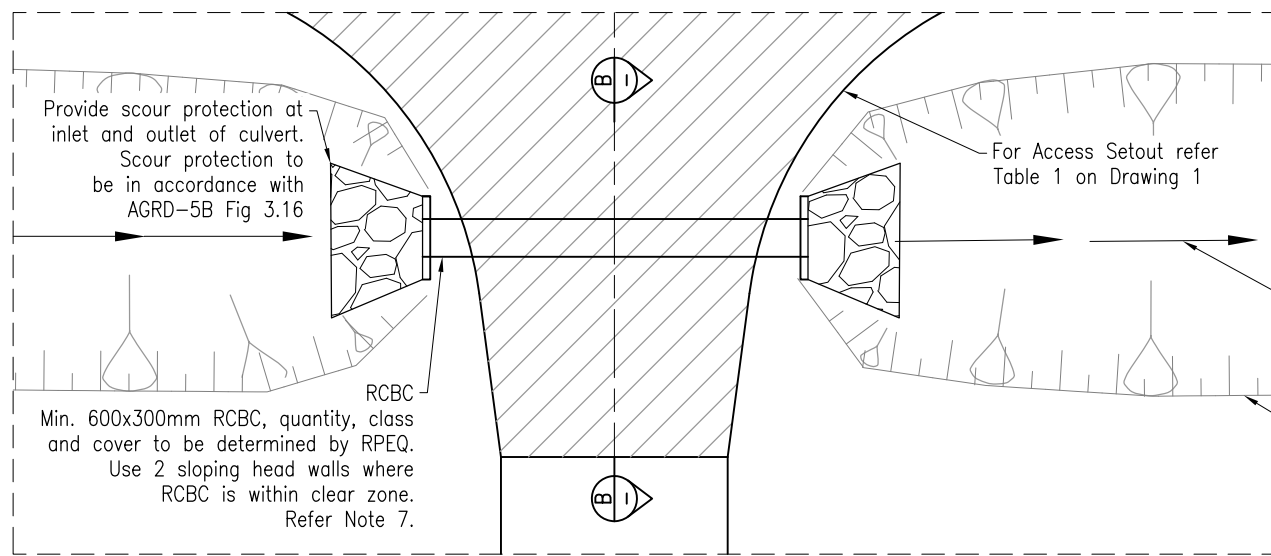

RC BOX CULVERT PLAN VIEW

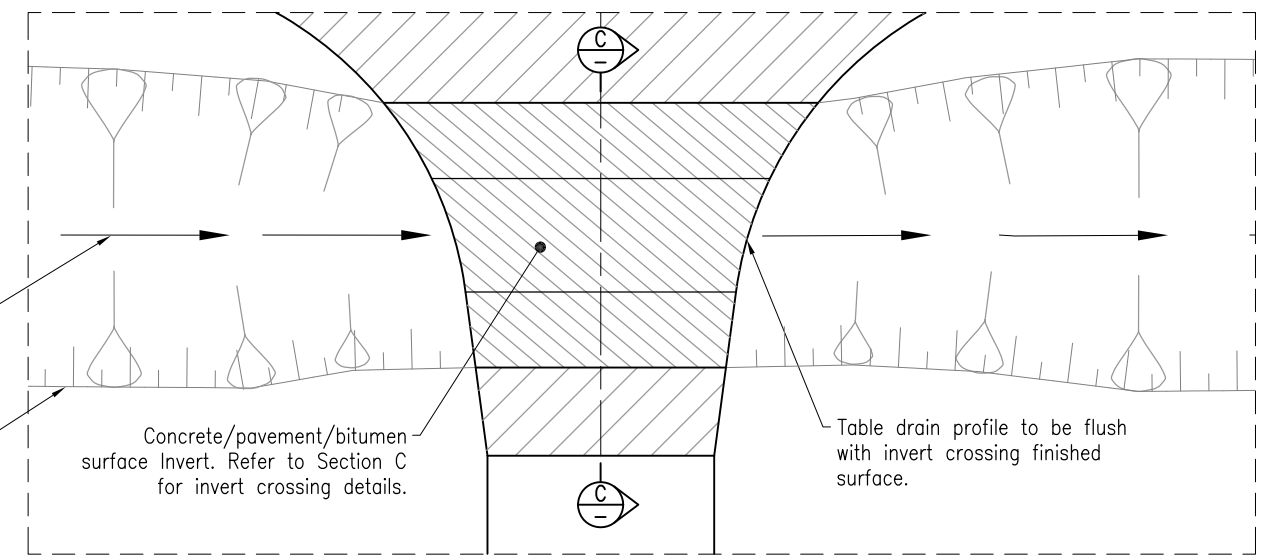

INVERT CROSSING PLAN VIEW

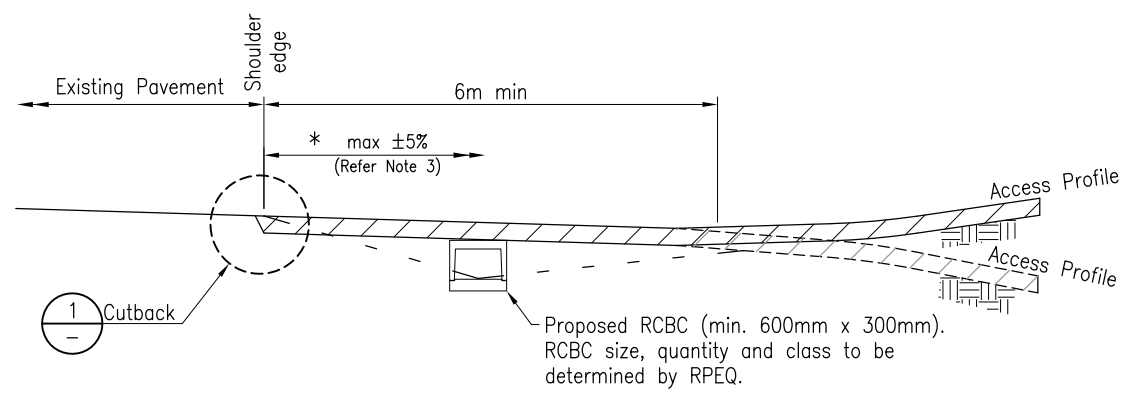

ON STRAIGHTS AND INSIDE OF CURVES

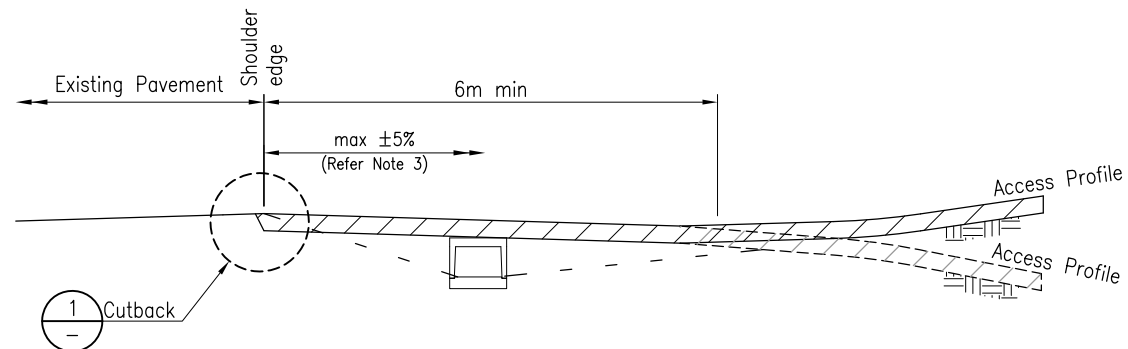

ON OUTSIDE OF SUPERELEVATED CURVES

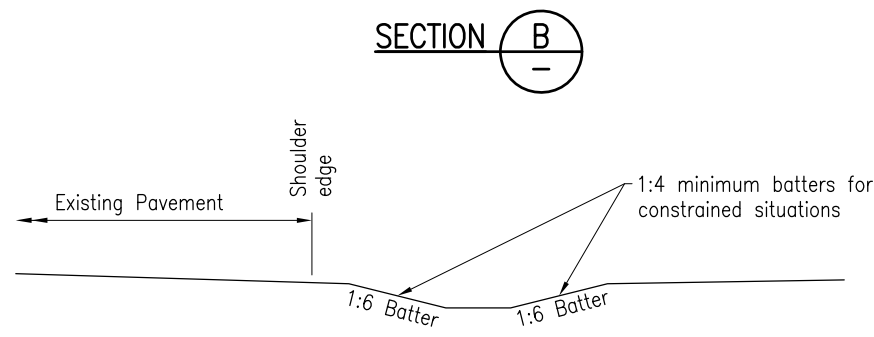

BATTER DETAIL

DETAIL 2

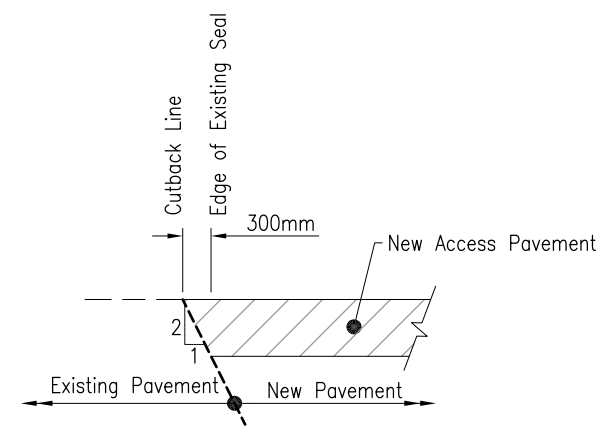

CUTBACK DETAIL

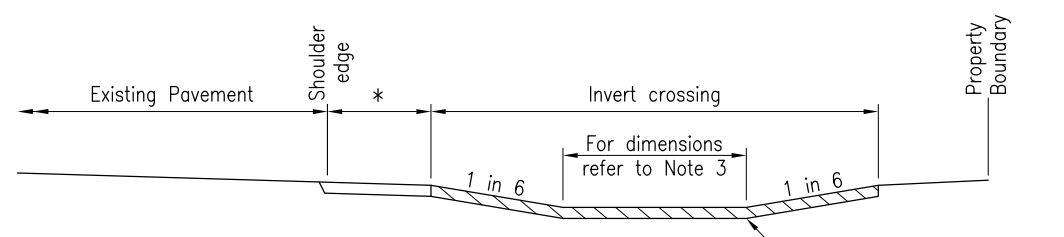

DETAIL 1



INVERT CROSSING

SECTION C

LEGEND



-  Pavement Type 2 – Gravel, unbound pavement. Refer to Table 2 of Drawing 1 for depths. Access may be required to be sealed for up to 10m width from edge line (to minimize gravel on through road) to be determined by the RPEQ.
-  Invert crossing surface
- * Maintain existing shoulder crossfall and superelevation.

NOTES:

1. This drawing is to be read in conjunction with Drawing 1 of 2.
2. Minimum longitudinal fall for concrete or bitumen invert is 0.3%.
3. 1 in 6 grade can be further levelled for larger design vehicles. Ensure sufficient area for drainage remains. Dimensions to be based on stormwater flow rate for appropriate design ARI event to ensure invert crossing can meet required capacity. Type 22 and Type 28 inverts can be used if drainage design criteria is met.
4. Vertical clearance checks to be carried out for small rigid vehicle to ensure adequate transition between change in grade. Refer to AS 2890.2.
5. For pavement or bitumen surfacing inverts, refer Table 2 on Drawing 1 for minimum depths.
6. Concrete access to have minimum N32 concrete, 100mm thick on 100mm thick sub-base gravel. Concrete access to be reinforced with SL72 mesh with minimum 40mm top cover.
7. Culvert clear zone varies with location and speed environment. Refer to TMR Road Planning and Design Manual – Supplement to AGRD Part 6, and Austroads Guide to Road Design - Part 6.

REFERENCED DOCUMENTS:

- Departmental Standard Drawings:
- 1260 R C Box Culverts and Slab Link Box Culverts – Culverts Height = 375 To 600
 - 1033 Kerb and Channel – Profiles
- Australian Standards Documents:
- AS2890.2 Parking Facilities – Off-Street Commercial Vehicle Facilities

Department of Transport and Main Roads		 <small>© The State of Queensland (Department of Transport and Main Roads) 2020 http://creativecommons.org/licenses/by/3.0/au</small>	
PROPERTY ACCESS			
RURAL PROPERTY ACCESS DRAWING 2 OF 2		A3 Not to Scale A	Standard Drawing No 1807 Date 07/2020