

PLAN  
GENERAL LAYOUT (BRIDGE SKEWED GREATER THAN 20°)

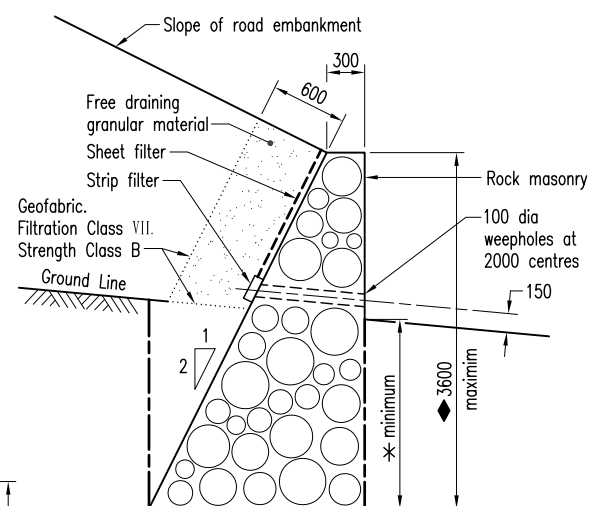

SECTION B

- \* Refer to the project specific drawings for actual dimensions
- ∅ For bridges skewed greater than 20° the stream hydraulics should be checked to ensure that scour cannot occur behind the wings
- ◆ If a greater height is required, an engineering design must assess the suitability of the foundation material and the backslope of the protection
- For columns the rock masonry shall line up with the front face of the abutment

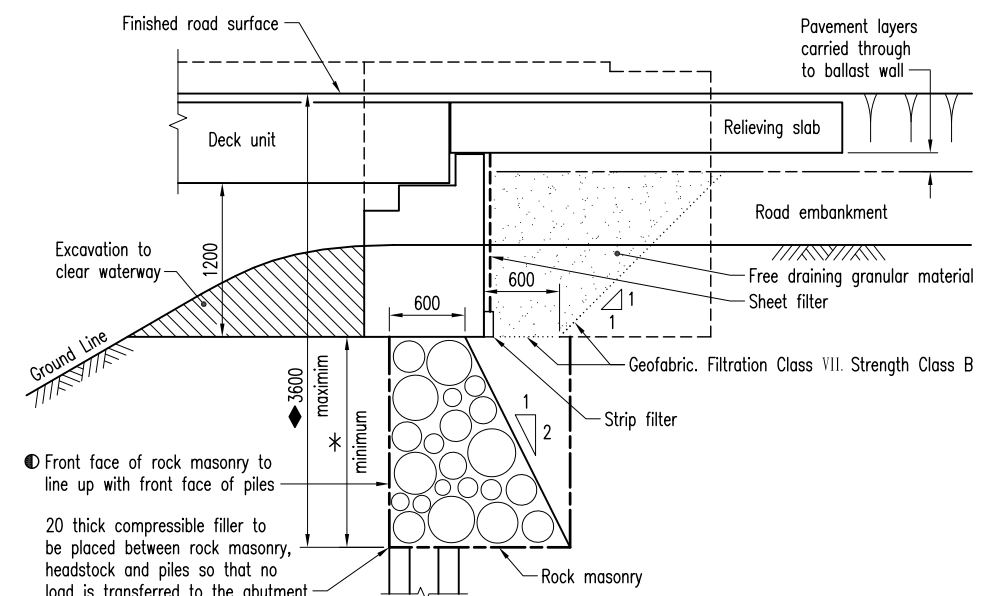

SECTION A EXCAVATION TO PROVIDE 1200 CLEARANCE

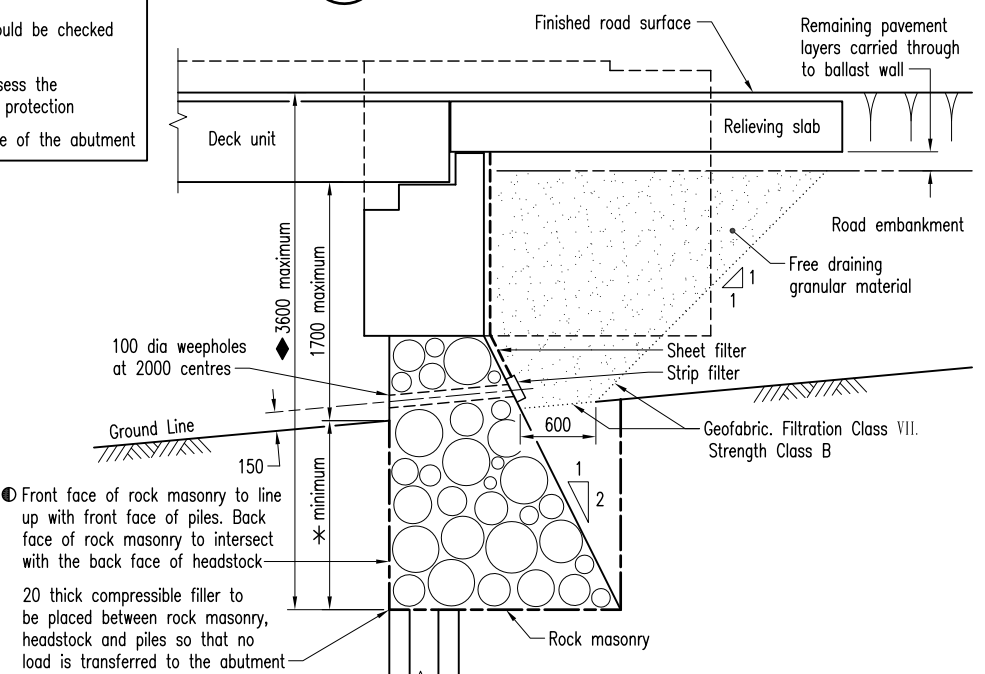

SECTION A CLEARANCE BETWEEN 1200 AND 1700

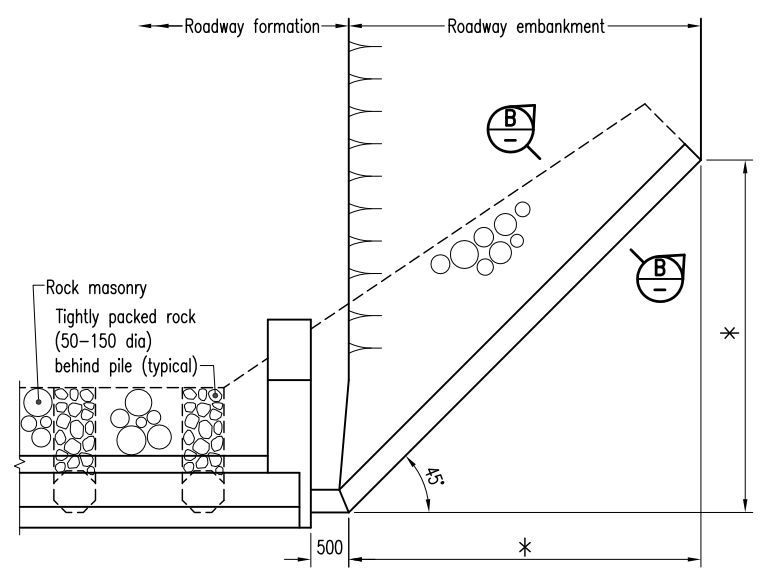

PLAN

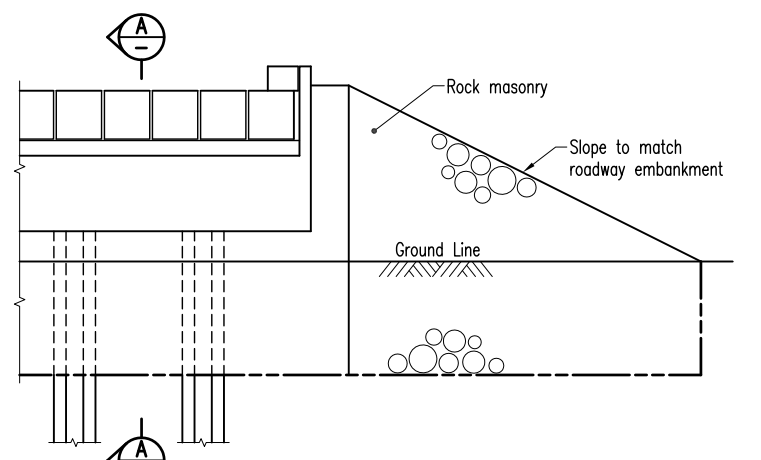

ELEVATION  
GENERAL LAYOUT (BRIDGE SKEWED UP TO 20° SKEW)

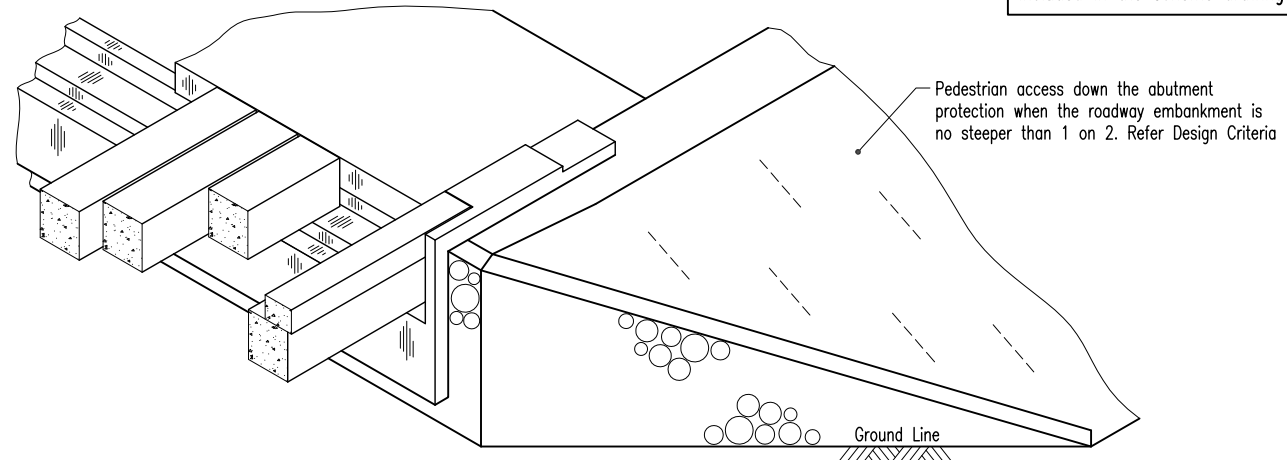

ROCK MASONRY PROTECTION  
(SQUARE BRIDGE SHOWN - SKEWED BRIDGE SIMILAR)

**DESIGN CRITERIA**

The purpose of this drawing is to provide standard details only and fitness for purpose shall be determined and certified by the bridge design engineer. Because every abutment protection is designed to suit its specific location, this drawing shall be read in conjunction with the project specific drawings.

MRTS03 allows for rock masonry walls to be substituted with unreinforced S20/20 mass concrete walls (if approved by the Superintendent). Suitable rock quality and a tradesmen with considerable experience in rock masonry is needed to build a durable wall. Because such tradesmen are rare and a poorly constructed rock masonry wall will quickly fail, mass concrete walls are preferred.

Rock masonry is an inferior form of abutment protection compared to other standard forms of protection. Therefore, its use should be limited to the widening of existing bridges that already have rock masonry.

In accordance with Workplace Health and Safety requirements, abutment headstocks must be easily accessible to allow them to be inspected and maintained. Where the clearance is no greater than 1700 high, this can be done by walking around the base of the protection. If the clearance is greater than 1700, a platform shall be provided 1700 from the underside of the bridge. Because a platform cannot be easily built into rock masonry, alternate forms of protection should be used when the clearance is greater than 1700.

Provided that the roadway embankment is no steeper than 1 on 2, access to the underside of the bridge shall be by walking down the road embankment. If the embankment is steeper than 1 on 2, a risk assessment shall determine the best method of accessing the underside of the bridge. This may be by walking down the road embankment where it is not too steep or by connecting a safety harness to a guardrail post for access down the embankment. Roadway embankments steeper than 1 on 2 must be protected.

When designing abutment protection, consideration must be given to the strength of the subgrade material. The protection must be founded in material CBR20 or better. The backfill material must be compacted to 95% RDD. Expansive clays are not suitable.

The possibility of scour at the protection must be assessed at each abutment. The depth of the protection into the ground must be designed to accommodate the depth of scour expected.

**Note:** The purpose of this drawing is to provide typical standard details. The fitness for purpose of this drawing for a specific project shall be determined and certified by a RPEQ engineer. Project specific details may be required to be included in the scheme drawings.

- NOTES:**
1. This drawing was previously Std Drg 1548.
  2. Refer Design Criteria for Bridges and Other Structures for the abutment protection type selection criteria.
  3. PAYLINES for excavation shown thus
  4. DIMENSIONS are in millimetres unless shown otherwise.

**ASSOCIATED DEPARTMENTAL DOCUMENTS:**

- Standard Drawings
- Specifications
- Bridge Scour Manual
- Design Criteria for Bridges and Other Structures

**Australian Standards:**  
AS 5100 Set Bridge Design

**Legislation:**  
Work Health and Safety Act 2011  
Work Health and Safety Regulations 2011

|                                        |  |              |                     |
|----------------------------------------|--|--------------|---------------------|
| Department of Transport and Main Roads |  |              |                     |
| ABUTMENT PROTECTION                    |  |              |                     |
| ROCK MASONRY                           |  | A3           | Standard Drawing No |
|                                        |  | Not to Scale | 2238                |
|                                        |  | A            | Date 4/15           |