

**Road Planning and Design Manual
Edition 2: Volume 3**

**Supplement to Austroads Guide to Road Design
Part 6A: Paths for Walking and Cycling**

July 2025



Copyright

© The State of Queensland (Department of Transport and Main Roads) 2025.

Licence



This work is licensed by the State of Queensland (Department of Transport and Main Roads) under a Creative Commons Attribution (CC BY) 4.0 International licence.

CC BY licence summary statement

In essence, you are free to copy, communicate and adapt this work, as long as you attribute the work to the State of Queensland (Department of Transport and Main Roads). To view a copy of this licence, visit: <https://creativecommons.org/licenses/by/4.0/>

Translating and interpreting assistance



The Queensland Government is committed to providing accessible services to Queenslanders from all cultural and linguistic backgrounds. If you have difficulty understanding this publication and need a translator, please call the Translating and Interpreting Service (TIS National) on 13 14 50 and ask them to telephone the Queensland Department of Transport and Main Roads on 13 74 68.

Disclaimer

While every care has been taken in preparing this publication, the State of Queensland accepts no responsibility for decisions or actions taken as a result of any data, information, statement or advice, expressed or implied, contained within. To the best of our knowledge, the content was correct at the time of publishing.

Feedback

Please send your feedback regarding this document to: tmr.techdocs@tmr.qld.gov.au

Relationship with Austroads Guide to Road Design – Part 6A (2021)

The Department of Transport and Main Roads has, in principle, agreed to adopt the standards published in the Austroads *Guide to Road Design Part 6A – Paths for Walking and Cycling*.

When reference is made to other parts of the Austroads *Guide to Road Design*, Austroads *Guide to Traffic Management* or the Austroads *Guide to Road Safety*, the reader should also refer to Transport and Main Roads related manuals:

- *Road Planning and Design Manual* (RPDM), and
- *Traffic and Road Use Management Manual* (TRUM).

Where a section does not appear in the body of this supplement, the Austroads *Guide to Road Design – Part 6A* criteria is accepted unamended.

This supplement:

1. has precedence over the Austroads *Guide to Road Design – Part 6A* when applied in Queensland
2. details additional requirements, including *accepted with amendments* (additions or differences), *new* or *not accepted*, and
3. has the same structure (section numbering, headings and contents) as Austroads *Guide to Road Design – Part 6A*.

The following table summarises the relationship between the Austroads *Guide to Road Design – Part 6A* and this supplement using the following criteria:

Accepted	Where a section does not appear in the body of this supplement, the Austroads <i>Guide to Road Design – Part 6A</i> is accepted.
Accepted with amendments	Part or all of the section has been accepted with additions and/or differences.
New	There is no equivalent section in the Austroads Guide.
Not accepted	The section of the Austroads Guide is not accepted.

Relationship table

Section	Title	Queensland application	Department contact	
1	Introduction			
	1.1	Purpose	Accepted	Road Design
	1.2	Scope of this Part	Accepted	Road Design
	1.3	Safe System Approach	Accepted	Road Design
2	Types of Path			
	2.1	General	Accepted	Road Design
	2.2	Pedestrian Path	Accepted	Road Design
	2.3	Bicycle Path	Accepted with amendments	Road Design
	2.4	Shared Path	Accepted	Road Design
	2.5	Separated Path	Accepted with amendments	Road Design
3	Path User Considerations			
	3.1	General	Accepted with amendments	Road Design
	3.2	Operating Space	Accepted with amendments	Road Design
4	Design Considerations			
	4.1	Location of Paths	Accepted	Road Design
	4.2	Factors of Influence – Path Location	Accepted	Road Design
	4.3	Path Width	Accepted	Road Design
	4.4	Bicycle Paths	Accepted	Road Design
5	Design Criteria			
	5.1	Width of Paths	Accepted with amendments	Road Design
	5.2	Bicycle Operating Speeds	Accepted with amendments	Road Design
	5.3	Horizontal Curvature	Accepted	Road Design
	5.4	Path Gradients	Accepted with amendments	Road Design
	5.5	Clearances, Batters and Need for Fences	Accepted with amendments	Road Design
	5.6	Crossfall and Drainage	Accepted	Road Design
	5.7	Sight Distance	Accepted with amendments	Road Design
	5.8	Changes in Level	Accepted with amendments	Road Design
	5.9	Surface Treatments	Accepted with amendments	Road Design
	5.10	Surface Tolerances	Accepted	Road Design
	5.11	Lighting	Accepted	Road Design
5.12	Underground Services	Accepted	Road Design	

Section	Title	Queensland application	Department contact	
6	Intersections of Paths with Paths			
	6.1	General	Accepted	Road Design
	6.2	Intersection Priority	Accepted	Road Design
	6.3	Intersection Signs	Accepted	Road Design
	6.4	Treatments for Intersections of Paths with Paths	Accepted with amendments	Road Design
	6.5	Special Treatments for Intersections of Paths with Paths	Accepted with amendments	Road Design
7	Intersections of Paths with Roads			
	7.1	General	Accepted with amendments	Road Design
	7.2	Intersection Signs	Accepted	Road Design
	7.3	Treatments for Intersections of Paths with Roads	Accepted with amendments	Road Design
	7.4	Ancillary Devices for Intersections of Paths with Roads	Accepted	Road Design
	7.5	Special Treatments for Intersections of Paths with Roads	Accepted with amendments	Road Design
8	Paths at Structures			
	8.1	General	Accepted	Road Design
	8.2	Road Bridges	Accepted with amendments	Road Design
	8.3	Underpasses	Accepted with amendments	Road Design
	8.4	Bicycle Wheeling Ramps	Accepted	Road Design
9	Construction and Maintenance Considerations for Paths			
	9.1	General	Accepted with amendments	Road Design
	9.2	Bicycle Safety Audits	Accepted	Road Design
References				
	References	Accepted with amendments	Road Design	
Appendices				
A	Application of Envelopes and Clearances to Determine the Widths of Paths	Accepted	Road Design	
B	Speed Limiting Treatments	Accepted with amendments	Road Design	
C	Path Construction and Maintenance	Accepted	Road Design	
D	Bicycle Safety Audit Checklist	Accepted	Road Design	

Section	Title	Queensland application	Department contact
	Commentaries		
	1	Accepted	Road Design
	2	Accepted	Road Design
	3	Accepted	Road Design

Departmental contacts

- Director (Road Design), Road Design, Hydraulics, Design and Spatial, Engineering and Technology, Transport and Main Roads email: roaddesignstandards@tmr.qld.gov.au

Contents

- Relationship table..... ii**
- Departmental contacts..... iv**
- 2 Types of Path 1**
- 2.3 Bicycle Path 1
- 2.5 Separated Path 1
- 3 Path User Considerations..... 3**
- 3.1 General 3
- 3.2 Operating space 3
 - 3.2.1 *Pedestrians*..... 3
- 5 Design Criteria 3**
- 5.1 Width of Paths..... 3
 - 5.1.1 *Clear width*..... 3
 - 5.1.4 *Shared paths* 3
- 5.2 Bicycle Operating Speeds 4
- 5.4 Path Gradients 5
 - 5.4.1 *Universal access* 6
 - 5.4.2 *Ease of uphill travel*..... 6
- 5.5 Clearances, Batters and Need for Fences 7
 - 5.5.1 *Clearances* 7
 - 5.5.3 *Batters and fences*..... 7
- 5.7 Sight Distance 8
 - 5.7.1 *Bicycle path stopping sight distance* 8
- 5.8 Changes in Level 8
- 5.9 Surface Treatments 9
- 6 Intersections of Paths with Paths 9**
- 6.4 Treatments for Intersections of Paths with Paths 9
- 6.5 Special Treatments for Intersections of Paths with Paths 9
- 7 Intersections of Paths with Roads..... 9**
- 7.1 General 9
- 7.3 Treatments for Intersections of Paths with Roads..... 10
- 7.5 Special Treatments for Intersections of Paths with Roads..... 10
 - 7.5.1 *General*..... 10
 - 7.5.2 *Terminal design principles*..... 10
 - 7.5.3 *Terminal treatments for excluding vehicles*..... 11
 - 7.5.4 *Terminal treatments for high-conflict locations*..... 12
- 8 Paths at Structures..... 12**
- 8.2 Road Bridges 12
- 8.3 Underpasses..... 12
 - 8.3.1 *General*..... 12
- 9 Construction and Maintenance Considerations for Paths 12**
- 9.1 General 12

References	14
Appendix B Speed Limiting Treatments	15

Tables

Table 6A-1 – Methods for separation of cyclists from pedestrians	1
Table 6A-2 - Shared path capacity for different widths	4
Table 6A-3 - Path speed-limiting devices.....	4

Figures

Figure 6A-1 - Example of full barrier fence (Section A-A).....	7
Figure 6A-2 – Visibility splays at intersections with paths.....	9

2 Types of Path

2.3 Bicycle Path

Addition

Transport and Main Roads Guideline *Selection and Design of Cycle Tracks* provides additional guidance for paths within road corridors in line with the safe system philosophy.

2.5 Separated Path

Difference

Delete the below sentence in Section 2.5 paragraph 2 of Austroads *Guide to Road Design – Part 6A*.

However, separated paths should not be provided in busy shopping centres where large numbers of pedestrians are expected to cross the path and conflict with cyclists.

Addition

Evidence from the implementation of subtle separation on Goodwill Bridge indicates that separation can reduce pedestrian and bicycle conflict even in busy areas with often unpredictable paths of travel.

Transport and Main Roads Guideline *Maintenance Minimisation for Walking and Cycling Facilities* provides detailed discussion on drainage management. A number of illustrations are provided in Transport and Main Roads Guideline *Speed Management on Shared Paths* to assist in design.

As both commuter cyclists and pedestrians prefer the most direct routes, chicanes and detours will often be bypassed by path users. Where separated paths are located close to scenic attractions such as foreshores and viewpoints, it is preferable to locate the footpath close to these attractions to minimise the instances of pedestrians wishing to cross the bicycle path.

Table 6A-1 provides advice on the most common means of separating cyclists from pedestrians.

Table 6A-1 – Methods for separation of cyclists from pedestrians

Visual Separation (Level surface separation)		
Type	Advantages	Disadvantages
White dividing line	<ul style="list-style-type: none"> Inexpensive Minimal width take-up, and Easier to maintain than physically segregated routes. 	<ul style="list-style-type: none"> Not detectable by tactile means Often ignored, and Might be visually intrusive.
Low profile raised line or concrete edge or border	<ul style="list-style-type: none"> Detectable by tactile means Inexpensive Minimal width take-up, and Easier to maintain than physically segregated routes. 	<ul style="list-style-type: none"> Can be difficult to construct properly, which might present a trip / cycle hazard Often ignored Can impede surface drainage unless gaps are provided, and Might be visually intrusive.
Contrasting pavement surfaces, e.g. concrete footpath beside asphalt bicycle path	<ul style="list-style-type: none"> Might be detectable by tactile means Minimal width take-up, and Easier to maintain than physically segregated routes. 	<ul style="list-style-type: none"> Likely to be ignored.

Visual Separation (Level surface separation)		
Type	Advantages	Disadvantages
Surface texture, e.g. a grassed at grade median strip	<ul style="list-style-type: none"> • Detectable by tactile means • Inexpensive, and • Can be easier to maintain than physically segregated routes. 	<ul style="list-style-type: none"> • Takes up more width than a white line.
Vertical Separation (Separation by level difference)		
Footpath and bicycle path separated by level difference and standard height or low kerb	<ul style="list-style-type: none"> • Detectable by tactile means, and • Effective. 	<ul style="list-style-type: none"> • Can be a hazard for cyclists if width is limited • Can be very expensive compared with level surface separation • Likely to be more expensive than barrier separation • Might make maintenance more difficult • Some additional width required • Can be difficult for wheelchair users if width is inadequate, and • Can present a barrier for some disabled people.
Physical Separation (Separation by barrier)		
Wall or railings	<ul style="list-style-type: none"> • Detectable by tactile means, and • Effective. 	<ul style="list-style-type: none"> • Can be a hazard for cyclists, especially where width is limited • Can trap users on the wrong side • Can seriously hamper maintenance • Significantly reduces effective width so route will need to be wider overall • More expensive than level surface separation, and • Might be visually intrusive.
Row of bollards	<ul style="list-style-type: none"> • Detectable by tactile means. 	<ul style="list-style-type: none"> • Can present a significant hazard for cyclists and visually impaired people • Likely to be ineffective • Can seriously hamper maintenance • Significantly reduces effective width so route will need to be wider overall • More expensive than level surface separation, and • Might be visually intrusive.
Plantings or hedges	<ul style="list-style-type: none"> • Detectable by tactile means • Effective, and • Can be aesthetically pleasing. 	<ul style="list-style-type: none"> • Can trap users on the wrong side • Can seriously hamper maintenance • Significantly reduces effective width so route will need to be wider overall • Unchecked growth can reduce route • Comfort and capacity • More expensive than level surface • Separation, and • The vegetation requires maintenance.

3 Path User Considerations

3.1 General

Addition

For more information in relation to the design principles, refer to Transport and Main Roads Guideline [Selection and design of cycle tracks](#) Section 3.1.

3.2 Operating space

3.2.1 Pedestrians

Addition

Tactile Indicators

Tactile Ground Surface Indicators (TGSI) are designed to give directional guidance and warning of hazards to people with a vision impairment. They are detected through contact by foot or cane.

TGSI are manufactured out of synthetic rubber, ceramic and clay tiles and stamped concrete. Some TGSI are suited to indoor and/or lightly trafficked areas rather than outdoor footpaths. The Compliant Products Register for Tactile Ground Surface Indicators (TGSI) available on the Transport and Main Roads website lists products that meet the criteria required for outdoor use.

All TGSI must conform to Australian Standard AS 1428.4.1 (also refer to Transport and Main Roads Standard Drawings SD1446, SD1447, KRG1 and KRG2).

5 Design Criteria

5.1 Width of Paths

5.1.1 Clear width

Addition

Path capacity is only increased in 1 m width intervals, intermediate widths (for example, 2.4 m or 3.7 m) are unlikely to improve capacity.

5.1.4 Shared paths

Difference

All of the text, including Table 5.3, in this section of Austroads *Guide to Road Design – Part 6A* is replaced with the following:

In most circumstances, the minimum standard for new shared paths should be 3 m wide.

Park maintenance vehicles can typically operate on 2.5 m wide paths in dry conditions without causing damage to the path. For this reason, 2.5 m should be the minimum standard for shared paths.

The design width of a path also depends on the number of pedestrians per hour, the number of cyclists per hour, and the design directional split. Table 6A-2 provides values for 90/10 directional split.

Table 6A-2 - Shared path capacity for different widths

Pedestrians per hour	Cyclists per hour		
	2.5 m path	3 m path	4 m path
0	730	1,380	2,420
20	440	1160	2,200
50	210	960	1990
100	–	770	1740
200	–	460	1440

Note: Based on 2-way peak-hour volumes 90/10 directional split, design maximum of 12 delayed overtakings per hour.

5.2 Bicycle Operating Speeds

Difference

Replace last sentence in this section with the following:

At locations where it is not appropriate to moderate bicycle speeds, consideration should be given to providing a separate pedestrian path.

Bicycle operation speeds may be estimated using the bicycle operation speed model (contact CyclePedTech@tmr.qld.gov.au).

Research undertaken by Transport and Main Roads found no defensible justification for imposing regulatory speed limits, and as a consequence would not use or recommend them as a safety device. Alternative treatment methods may be as or more effective as a safety device, avoiding the negative connotations associated with regulation. The Transport and Main Roads Guideline *Speed Management on Shared Paths* concludes that the cycling community is able to self-moderate speeds that are appropriate to the location without regulation.

The below Table 6A-3 replaces Appendix B, Table B1 in Austroads *Guide to Road Design – Part 6A*.

Table 6A-3 - Path speed-limiting devices

Device	Recommended	Comments	Queensland practice additional comments
Speed humps	Yes	Can destabilise riders and increase hazards if poorly sited or inadequately marked. Use with care. Fit warning signage and path markings similar to road speed humps.	Watts or sinusoidal profile speed humps are acceptable.
Path narrowing	Yes	Minimum one-way width 1.4 m. Warning signage and adequate linemarking required.	Only appropriate where narrowing is not expected to result in path user conflict.
Path deflection	Yes	Maximum deflection angle 10 degrees for high-speed path and 20 degrees for low-speed path.	

Device	Recommended	Comments	Queensland practice additional comments
Path terminal deflection rails	No	Can destabilise riders and increase hazards if used as speed limiting device. Used only to prevent unauthorised vehicle entry.	
Rumble strips	Yes	Use as a warning device to alert riders to slow for changed conditions ahead.	Tactile (surface change) is acceptable.
Warning signage	Yes	Used to warn of approaching hazard and to advise of need to reduce speed. Used in conjunction with other methods.	
Holding rails	No	Only used at intersections as a temporary prop.	Not suitable as a speed limiting device.
Bollards	No	Not recommended as a speed control device. Only used to prevent unauthorised vehicle entry.	
Alternative paving	Yes	Use different materials and colours.	

The Transport and Main Roads Guideline *Speed Management on Shared Paths* provides additional guidance.

5.4 Path Gradients

Addition

The Queensland *Anti-Discrimination Act 1991* and the Queensland *Human Rights Act 2019* shall be considered when designing paths for people walking or riding.

Normal Design Domain (NDD) for pedestrian path grades are those outlined in AS 1428 *Design for access and mobility* for walkways and ramps. AS 1428 *Design for access and mobility* gradient and landing requirements are based on the physical capabilities of people; these capabilities do not change if the person is inside a building or outdoors.

The National Construction Code (NCC) should only be referred to where relevant building classifications apply. Compliance with the NCC requirement for a maximum ramp height of 3.6 m would result in most pedestrian overpasses of roads to include elevators. This may be justified in high volume locations such as bus or rail interchanges. However, road overpasses located away from areas of high pedestrian activity are preferably serviced by walkways, ramps and stairs. Operation of elevators in isolated locations may be problematic regarding operational reliability and personal security.

AS 1428 *Design for access and mobility* compliance does not guarantee functional or dignified accessibility. Experienced and accredited Access Consultants can provide specialist advice on accessibility, functionality, universal design, and performance solution mitigating treatments, where strict compliance with AS 1428 *Design for access and mobility* is not feasible. 'Performance solution' has a similar meaning to Extended Design Domain (EDD) and Design Exception (DE). Accredited Access Consultants can be found through Association of Consultants in Access Australia.

The Queensland *Anti-Discrimination Act 1991* includes a hardship provision which may provide a basis for defending a design that does not conform to AS 1428 *Design for access and mobility*. Hardship defensibility is never guaranteed; defensibility will be aided by genuinely seeking accessible outcomes in the first instance. A design exception report justifying the reasons for non-compliance and mitigating measures implemented to provide equivalent accessibility is recommended to defend against future discrimination or human rights claims. Design exception report justifications need to be robust and may need to detail issues such as:

- Options investigated seeking compliance
- Compliance is demonstrated to entail significant impacts on the wider community (for example, extensive resumptions, afflux flooding)
- Compliance is demonstrated to result in safety or security issues either directly to facility users or indirectly to nearby people or facilities
- Compliance is demonstrated to incur unreasonable expenditure based on the justifiable scale or scope of the project
- Program limitations and competing demands limit sufficient funding to achieve an accessible facility (funding should be sought for the accessible option)
- Consultation with local people with a disability or representative groups (such as the Transport and Main Roads Accessibility Reference Group) have taken place in relation to project constraints and co-design of mitigating treatments have been accepted, and
- Mitigating treatments implemented to provide functional access to meaningful destinations. Examples of potential mitigations (not an exclusive list):
 - offline landings or rest areas abutting the path
 - alternative accessible path,
 - additional accessible parking, and/or
 - bus stops at crests and sags.

5.4.1 Universal access

Addition

For universal access, a desirable path gradient is 3% or less. Path gradients exceeding 5% increase effort significantly and should only be considered where other solutions are not feasible.

5.4.2 Ease of uphill travel

Addition

Figure 5.6 of Austroads *Guide to Road Design – Part 6A* shows desirable and acceptable lengths of uphill gradient for cyclists. The figure is based on a review of the ease of uphill travel (Andrew O'Brien & Associates, 1996). Steeper gradients may be acceptable in retrofit circumstances where provision of an access point overcomes more significant comfort or safety issues.

On grades steeper than 5%, cyclists tend to work the bicycle from side to side or wobble. The path width in the uphill direction should be widened by an additional 0.5 m to allow for this operating characteristic.

5.5 Clearances, Batters and Need for Fences

Addition

Clearances between fences and path users should be maximised where possible. Isolated fencing at headwalls should follow the alignment of the headwall and wing walls to maximise protection of path users and safety in design for maintenance workers.

Non-woven mesh is preferred. Fine aperture mesh (such as 358 mesh) can have anti-climb properties. Mesh with a minimum aperture less than 20 mm is considered 'smooth' and non-snagging for handlebars, pedals, and brake levers. To limit path user injury, the fence design should aim to align posts, frames, and mesh infill panels to be as smooth as possible on the path side of the fence. Horizontal strands of the mesh should face towards the path side of the fence and stiffening folds should face way from the path.

Difference

Figure 6A-1 replaces Austroads *Guide to Road Design – Part 6A*, Figure 5.12 (Section A-A) Example of a full barrier fence.

Figure 6A-1 - Example of full barrier fence (Section A-A)

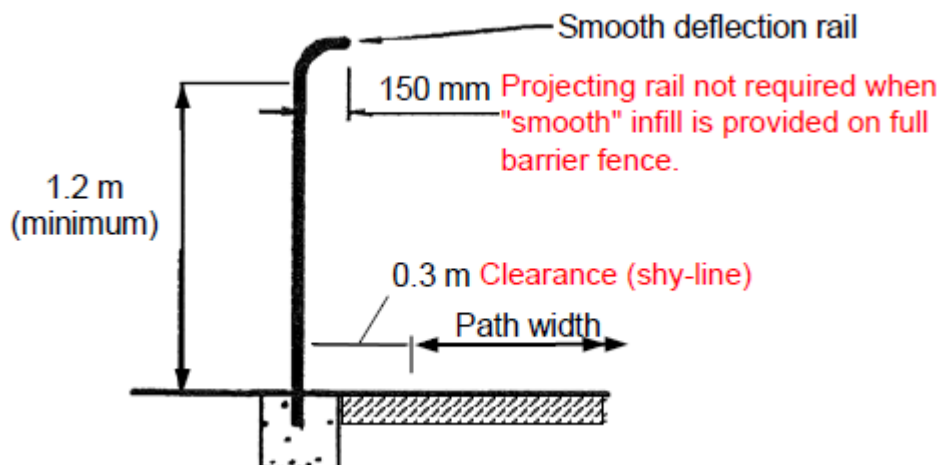

5.5.1 Clearances

Addition

On high-speed roads, the physical separation of off-road bikeways can be achieved with an appropriate safety barrier, allowing sufficient distance for the expected deflection of the barrier, or by an adequate separation distance. Transport and Main Roads RPDM Volume 3, Part 6 *Roadside Design, Safety and Barriers* should be reviewed for additional specific design guidance for clearances.

5.5.3 Batters and fences

Addition to General

All fencing adjacent to paths should consider if the hazard posed by fencing is less than the hazard of running off the path verge. Transport and Main Roads Guideline *Fencing and Edging Treatments for Cycling Infrastructure* provides the recommended risk assessment approach.

Fencing with horizontal rails must not be used within the clear zone or in any location where there is the possibility of impaling an impacting vehicle.

Where a safety barrier is erected adjacent to a bicycle path (i.e., the path behind the barrier), measures to protect pedestrians and cyclists from any sharp edges of barrier posts may need to be considered. This is to minimise the risk of catching pedals and clothing on the sharp posts, resulting in cyclists / pedestrians falling against and/or over the guardrail. In providing this protection, it is essential that the operation of the guardrail, in particular, that of the end treatment, is not affected.

Addition

Insert the following text on p.39 after paragraph 1 of Austroads *Guide to Road Design – Part 6A* after the sentence '*The infill panels of a fence should also have a fine weave mesh or similar to prevent bicycle wheels from being trapped or catching in the fence panel*':

Clearances between fences and path users should be maximised where possible. Isolated fencing at headwalls should follow the alignment of the headwall and wing walls to maximise protection of path users and safety in design for maintenance workers.

5.7 Sight Distance

Addition

By definition, sight lines should be unobstructed.

Isolated objects with widths of less than 300 mm are unlikely to have a significant effect on visibility and may be ignored if removal is not practicable. (Source: *UK DRMB Volume 6, Section 3, Part 5 TA90/05*) <https://www.standardsforhighways.co.uk/search/9b379a8b-b2e3-4ad3-8a93-ee4ea9c03f12>

Difference

Replace last sentence in Section 5.7 of Austroads *Guide to Road Design – Part 6A* with the following:

Sufficient sight distance needs to be provided to enable path users to stop or take evasive action, if necessary, in order to avoid another cyclist, pedestrian, or an obstacle in their path.

5.7.1 Bicycle path stopping sight distance

Difference

Equation incorporates rounding that adds about 0.5 m to stopping sight distance.

Use stopping sight distance formula in Austroads *Guide to Road Design – Part 3* Section 5.3.

5.8 Changes in Level

Addition

Additional text before the first sentence in Section 5.8 of Austroads *Guide to Road Design – Part 6A*:

A direct path of travel by stairs may be preferred by people capable of using stairs. Intertwining of access ramp landings and staircase landings is a method to ensure universal design while maximising passive surveillance for people using the ramps. The entry and exit points of the stairs and the accessible path should be co-located so far as is reasonably practical. This approach is also applicable to intertwining of accessible paths and non-accessible paths without stairs.

5.9 Surface Treatments

Addition

The Compliant Products Register for Tactile Ground Surface Indicators (TGSIs) available on the Transport and Main Roads website lists products that meet the criteria required for outdoor use.

6 Intersections of Paths with Paths

6.4 Treatments for Intersections of Paths with Paths

Difference

Modify diagram to remove pedestrian symbols from bicycle path in Austroads *Guide to Road Design – Part 6A* Section 6.4, Figure 6.1 (b) *Intersection of Shared Paths*.

Modify diagram to add 2.5 m radius to Austroads *Guide to Road Design – Part 6A* Section 6.4, Figure 6.3 (b) *Intersection of bicycle path and pedestrian path where cyclists have priority* and Figures 6.4 (a) and (b) *Intersection of a shared path and separated path where pedestrians have priority*.

6.5 Special Treatments for Intersections of Paths with Paths

Addition

On high volume paths, additional widening and CHR style delineation should be considered to permit right-turners to store clear of through traffic.

7 Intersections of Paths with Roads

7.1 General

Addition

Figure 6A-2 – Visibility splays at intersections with paths

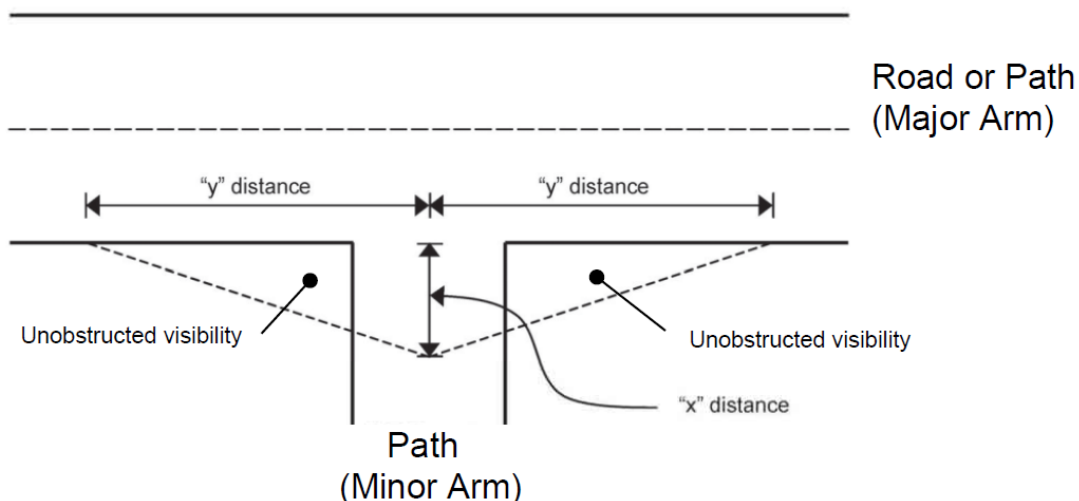

Visibility splays at intersections of paths should be provide in accordance with Figure 6A-2 where:

- 'x' distance = Desirably 4 m, 2.5 m in constrained retrofit circumstances or 2 m for pedestrian only paths.
- 'y' distance = Bicycle or motor vehicle stopping sight distance + observation time (typically 3 seconds; refer SISD guidance in *Austroads Guide to Road Design – Part 4A*).

7.3 Treatments for Intersections of Paths with Roads

Difference

Replace text in *Austroads Guide to Road Design – Part 6A*, last sentence of second paragraph:

If this proves to be insufficient to overcome the safety issue, it may be necessary to add special termination treatments designed to slow cyclists (Section 7.5).

With the following:

If this proves to be insufficient to overcome the safety issue, it may be necessary to modify approach geometry or gradients. Table 6A-3 discusses the appropriateness of other control options. Also refer to Appendix B.

7.5 Special Treatments for Intersections of Paths with Roads

7.5.1 General

Difference

In Queensland, path terminal treatments, in the form of physical barriers, shall not be used to either advise cyclists that there is a road ahead or slow cyclists down. Physical barriers shall not be installed as a measure to slow cyclists down as they limit the comfort and capacity of paths for all path users and cyclists have been seriously injured as a result of crashes into bollards.

The preferred method of advising people riding bikes of the road ahead is through the provision of clear sightlines and the use of traditional warning devices, such as signs and pavement markings. In most instances, the use of a 'GIVE WAY' (R1-2) or 'ROAD AHEAD' (W6-8) sign at the terminal will communicate all the required information to the cyclist. *Transport and Main Roads Queensland Guide to Traffic Management (QGTM) Part 6 Intersections, Interchanges and Crossing Management* provides additional guidance on assessing the need for path terminal treatments.

7.5.2 Terminal design principles

Addition

Access restriction devices to prevent unauthorised vehicle entry should only be installed if:

- there is a documented recurrent issue with unauthorised vehicle access
- the issue cannot be resolved by other methods (CCTV, police enforcement, path user reports), or
- vehicle access may damage path infrastructure (for example, a light weight bridge structure not designed to support vehicular load).

An escalating 3-step approach to access management is to be applied:

1. Install regulatory signs identifying the infrastructure as a path which prohibits motor vehicle entry. In the case of regular park vehicle use, install 'authorised vehicles only' and load limit signage at the entry.
2. Re-design path entry appearance to discourage vehicle access, and
3. Physical barriers to be used as a last resort, where the risk of damage to infrastructure from occasional unauthorised entry exceeds the risk of a permanent hazard to path users. If possible, provide separate authorised vehicular access for maintenance / emergency vehicles.

When path entry gates are used, these should be fitted with hazard marking and permanent, well-marked, 2-way paved bypass paths located to the side of the gate.

Separate entry and exit openings are preferred on all Principal Cycle Network (PCNP) routes and separated bicycle paths to improve capacity and reduce conflict between path users. Separate openings for each direction reduce the chances of collision, unanticipated stopping, blockage, and conflict at the terminal device.

Terminal restrictor bars (banana bars) may be duplicated in order to form 2 single direction paths to minimise cyclist and pedestrian conflict through the constrained section. Transport and Main Roads *Queensland Guide to Traffic Management (QGTM) Part 6 Intersections, Interchanges and Crossing Management* provides some examples.

Difference

In the last dot point, isolated vertical poles (for example, bollards) are to be at least 1.8 m high above the riding surface to heighten visibility. Low bollards (1 m minimum height) need to have a large impact surface to limit point (impaling) injury. Transport and Main Roads *Queensland Guide to Traffic Management (QGTM) Part 6 Intersections, Interchanges and Crossing Management* provides additional guidance for bollards.

7.5.3 Terminal treatments for excluding vehicles

Addition

Physical barriers (such as bollards or terminal restrictor bars) should be avoided where crash likelihood, severity, or cognitive demand is increased. Locations to avoid include:

- on a down grade $\geq 5\%$
- on a horizontal curve $\leq R50$ m
- at a location with restricted sight lines or visibility, or
- close to an intersection with other closely spaced conflict points or pedestrian activity.

Transport and Main Roads *Queensland Guide to Traffic Management (QGTM) Part 6 Intersections, Interchanges and Crossing Management* should be referred to for Transport and Main Roads preferred designs.

7.5.4 Terminal treatments for high-conflict locations

Difference

Transport and Main Roads does not endorse the use of Staggered Fence Treatment. This treatment should only be considered as a last resort in exceptional circumstances, where all other options have been exhausted.

8 Paths at Structures

8.2 Road Bridges

Addition

People throwing objects from overpass bridges can be an issue, and some form of caging may be required to ensure security for, and the safety of, the traffic below. The aesthetics of the caging must be an important consideration in its design. For design requirements and the risk assessment methodology, refer to Transport and Main Roads *Reduction of Risk from Objects Thrown from Overpass Structures onto Roads*, and its accompanying *Technical Guidelines for the Treatment of Overhead Structures*.

8.3 Underpasses

8.3.1 General

Addition

Subways should be lit. Murals can often be provided to discourage graffiti.

Longitudinal grades in the subway should be not less than 0.3% in one direction to allow for longitudinal drainage.

9 Construction and Maintenance Considerations for Paths

9.1 General

Addition

Surface defects

There is a range of surface defects that can occur across the variety of pavement materials. Typical defects include cracking, potholes, differential settlement, breaking up of surfaces, and slippery surfaces.

Vehicle damage due to loading or impact by vehicles, such as maintenance and emergency vehicles, are a cause of pavement damage. This can result in safety issues for cyclists and pedestrians due to cracking, sub-base failure and pavement failure.

Maintenance can be minimised if the following issues are considered in the planning phase:

- wherever practicable, locate bicycle and pedestrian paths where they will not be subjected to inundation, by adjusting the alignment or using structures
- consider future developments and construction works which may affect the facility, such as road widening in areas of high traffic growth; these activities may accelerate deterioration of the surface material

- avoid alignments on areas with poor soil characteristics, such as expansive clay areas, subject to instability and settlement
- if the facility is on-road and being retrofitted to an existing road, consult the original road design and maintenance history to identify the design, quality, and condition of the section of road being used, and the future plans for the road, and
- when widening an existing facility which is in good condition, the pavement should be matched to the existing, and any sub-soil or edge drains disrupted should be replaced.

Maintenance issues in the detailed design stage include:

- use a recognised pavement thickness design system or catalogue of bicycle way pavements based on the expected in-service loads
- ensure that joints are located appropriately for the terrain and conditions, and
- design for possible root infiltration.

Surface transitions

Where a path transitions from one surface to another, the discontinuity is prone to vertical displacement and this, combined with a change in surface friction, can create a hazard for cyclists and pedestrians. These transitions occur when a path meets a roadway, bridge, boardwalk, or another path. The roots of some trees growing too close to a path can lift the pavement, creating discontinuities at the joints and cracking. It is possible to substantially reduce the risk of vertical displacement by providing some form of physical interlocking, such as tie bars.

Pavement edge drop-off is an issue that is caused by erosion. Erosion is an issue that affects pedestrians and bicycle facilities located next to steep terrain, or where the landscape has been excavated to accommodate new infrastructure. In such terrain, well designed batters and drainage is required to minimise erosion and deposition on the path.

Vegetation and debris management

Vegetation, including trees, shrubs, herbaceous plants, and grass, can be a major maintenance problem, causing safety and path deterioration issues. Fallen leaves and debris can cause cyclists to crash. Vegetation can also cause blocked drains, water ponding, reduction in sight distances, and overhanging limbs intruding on pedestrian and cyclist operating envelopes.

Cycle path debris can include litter, windblown leaves and branches, sediment deposited by water crossing the facility, rocks falling from cuttings, and pavement damage. Most debris is a hazard to cyclists and it needs to be minimised by appropriate design and removed by regular maintenance, particularly after adverse weather events.

Further operational and best practice guidance is contained in Transport and Main Roads Guideline *Maintenance Minimisation for Walking and Cycling Facilities*.

References

Transport and Main Roads publication references refer to the latest published document on the departmental website www.tmr.qld.gov.au.

Addition

Austrroads. *Guide to Road Design – Part 6A – Paths for Walking and Cycling*. Sydney, NSW

Department of Transport and Main Roads. *Fencing and Edging Treatments for Cycling Infrastructure*. Brisbane: Queensland Government

Department of Transport and Main Roads. *Maintenance Minimisation for Walking and Cycling Facilities*. Brisbane: Queensland Government

Department of Transport and Main Roads. *Queensland Guide to Traffic Management (QGTM) Part 6 Intersections, Interchanges and Crossing Management*. Brisbane: Queensland Government

Department of Transport and Main Roads. *Reduction of Risk from Objects Thrown from Overpass Structures onto Roads*. Brisbane: Queensland Government

Department of Transport and Main Roads. *Selection and Design of Cycle Tracks*. Brisbane: Queensland Government

Department of Transport and Main Roads. *Speed management on shared paths*. Brisbane: Queensland Government

Department of Transport and Main Roads. *Technical Guidelines for the Treatment of Overhead Structures*. Brisbane: Queensland Government

Standards Australia. AS 1428.4.1 *Design for access and mobility Part 4.1: Means to assist the orientation of people with vision impairment – Tactile ground surface indicators*. Sydney NSW

Standards for Highways. *UK DRMB Volume 6, Section 3, Part 5 TA90/05*
<https://www.standardsforhighways.co.uk/search/9b379a8b-b2e3-4ad3-8a93-ee4ea9c03f12>. United Kingdom

Appendix B Speed Limiting Treatments

Difference

Delete final sentence in Appendix B Speed Limiting Treatments and Table B 1 Suggested path speed limiting treatments of Austroads *Guide to Road Design – Part 6A* and replace with Table 6A-3 which discusses the appropriateness of other control options.

