

**Road Planning and Design Manual
Edition 2: Volume 3**

**Supplement to Austroads Guide to Road Design
Part 6B: Roadside Environment**

July 2025

Copyright

© The State of Queensland (Department of Transport and Main Roads) 2025.

Licence



This work is licensed by the State of Queensland (Department of Transport and Main Roads) under a Creative Commons Attribution (CC BY) 4.0 International licence.

CC BY licence summary statement

In essence, you are free to copy, communicate and adapt this work, as long as you attribute the work to the State of Queensland (Department of Transport and Main Roads). To view a copy of this licence, visit: <https://creativecommons.org/licenses/by/4.0/>

Translating and interpreting assistance



The Queensland Government is committed to providing accessible services to Queenslanders from all cultural and linguistic backgrounds. If you have difficulty understanding this publication and need a translator, please call the Translating and Interpreting Service (TIS National) on 13 14 50 and ask them to telephone the Queensland Department of Transport and Main Roads on 13 74 68.

Disclaimer

While every care has been taken in preparing this publication, the State of Queensland accepts no responsibility for decisions or actions taken as a result of any data, information, statement or advice, expressed or implied, contained within. To the best of our knowledge, the content was correct at the time of publishing.

Feedback

Please send your feedback regarding this document to: tmr.techdocs@tmr.qld.gov.au

Relationship with Austroads Guide to Road Design – Part 6B (2021)

The Department of Transport and Main Roads has, in principle, agreed to adopt the standards published in the *Austroads Guide to Road Design – Part 6B: Roadside Environment*.

When reference is made to other parts of the *Austroads Guide to Road Design*, *Austroads Guide to Traffic Management* or the *Austroads Guide to Road Safety*, the reader should also refer to Transport and Main Roads related manuals:

- *Road Planning and Design Manual* (RPDM)
- *Queensland Guide to Road Safety* (QGRS)
- *Queensland Guide to Traffic Management* (QGTM), and
- *Traffic and Road Use Management Manual* (TRUM).

Where a section does not appear in the body of this supplement, the *Austroads Guide to Road Design – Part 6B* criteria is accepted unamended.

This supplement:

1. has precedence over the *Austroads Guide to Road Design – Part 6B* when applied in Queensland
2. details additional requirements, including *accepted with amendments* (additions or differences), *new* or *not accepted*
3. has the same structure (section numbering, headings and contents) as *Austroads Guide to Road Design – Part 6B*.

The following table summarises the relationship between the *Austroads Guide to Road Design – Part 6B* and this supplement using the following criteria:

Accepted	Where a section does not appear in the body of this supplement, the <i>Austroads Guide to Road Design – Part 6B</i> is accepted.
Accepted with amendments	Part or all of the section has been accepted with additions and/or differences.
New	There is no equivalent section in the <i>Austroads Guide</i> .
Not accepted	The section of the <i>Austroads Guide</i> is not accepted.

Relationship table

Section	Title	Queensland application	Department contact	
1	Introduction			
	1.1	Purpose	Accepted	Road Design
	1.2	Scope of this Part	Accepted	Road Design
	1.3	Design Objectives	Accepted	Road Design
	1.4	Factors to be Considered	Accepted	Road Design
2	Environmental Aspects			
	2.1	Stormwater Run-off	Accepted with amendments	Environment & Cultural Heritage
	2.2	Fauna Management	Accepted with amendments	Environment & Cultural Heritage
	2.3	Noise Control	Accepted with amendments	Road Design
	2.4	High Risk Soils	New	Road Design
	2.5	Contaminated Land	New	Environment & Cultural Heritage
	2.6	Cultural Heritage Aspects	New	Environment & Cultural Heritage
3	Roadside Amenity			
	3.1	Urban and Regional Design	Accepted	Road Design
	3.2	Visual Amenity	Accepted with amendments	Road Design
	3.3	Landscaping	Accepted with amendments	Road Design
	3.4	Rest Facilities	Accepted with amendments	Safer Roads / Road Design
	3.5	Roadside Vending Sites	New	Road Design
	3.6	Heavy Vehicle Interception Sites	New	Road Design / ITS & E Technology
	3.7	Queensland Police Service (QPS) Enforcement Bays	New	Safer Roads / Road Design
	3.8	De-coupling Pads	New	Road Design
	3.9	Stockpile Management	New	Environment & Cultural Heritage
	3.10	Extraction Sites	New	Environment & Cultural Heritage

Section	Title	Queensland application	Department contact	
4	Design Considerations			
	4.1	Road Furniture	Accepted with amendments	Road Design / Environment & Cultural Heritage
	4.2	Road Lighting	Accepted with amendments	ITS & E Technology
	4.3	Emergency / Help Telephones	Accepted with amendments	Network Management
	4.4	Off-street Parking	Accepted with amendments	Road Design / Traffic Engineering
	4.5	Utilities	Accepted with amendments	Environment & Cultural Heritage
	4.6	Intelligent Transport System Infrastructure	New	Road Design
5	Roadside Environment Safety Considerations			
	5.1	Animal / Vehicle Collisions	New	Road Design / Environment & Cultural Heritage
	5.2	Bushfire Risk Planning and Design	New	Road Design / Environment & Cultural Heritage
	References			
		References	Accepted with amendments	Road Design
	Appendices			
	A	Application of Envelopes and Clearances to Determine the Widths of Paths	Accepted	Traffic Engineering

Departmental contacts

Road Design, Hydraulics, Design and Spatial, Engineering and Technology, Transport and Main Roads email: roaddesignstandards@tmr.qld.gov.au

Safer Roads, Safer Roads Infrastructure, Engineering and Technology, Transport and Main Roads email: saferroads@tmr.qld.gov.au

Environment & Cultural Heritage, Program Delivery and Operations, Transport and Main Roads email: environment@tmr.qld.gov.au (Environment), TMR.Heritage@tmr.qld.gov.au (Cultural Heritage)

Network Management, Network Operations, Statewide Network Operations, Transport and Main Roads email: TManagement@tmr.qld.gov.au

Traffic Engineering, Safer Roads Infrastructure, Engineering and Technology, Transport and Main Roads email: CyclePedTech@tmr.qld.gov.au

ITS & E Technology, Operational Technologies, Statewide Network Operations, Transport and Main Roads email: SNO_ITSET_DFT@tmr.qld.gov.au

Contents

Relationship table	ii
Departmental contacts	iii
2 Environmental Aspects	1
2.1 Stormwater Run-off.....	1
2.1.1 <i>Drainage considerations</i>	1
2.1.3 <i>Erosion control</i>	1
2.2 Fauna Management.....	2
2.2.2 <i>Fauna crossings</i>	2
2.2.5 <i>Environmental offsets</i>	3
2.3 Noise Control.....	3
2.3.1 <i>General</i>	3
2.3.3 <i>Noise barriers</i>	3
2.4 High Risk Soils.....	3
2.5 Contaminated Land.....	6
2.6 Cultural Heritage Aspects.....	6
3 Roadside Amenity	7
3.1 Urban and Regional Design.....	7
3.2 Visual Amenity.....	7
3.3 Landscaping.....	7
3.3.2 <i>Safety</i>	7
3.3.3 <i>Design considerations</i>	7
3.3.4 <i>Landscaping specific situations</i>	8
3.4 Rest Facilities.....	9
3.4.1 <i>Need for rest facilities</i>	9
3.4.2 <i>Road design considerations for rest areas and service centres</i>	9
3.4.3 <i>Siting of service centres and rest areas</i>	13
3.4.4 <i>Design of service centres and rest areas</i>	16
3.4.5 <i>Signage</i>	28
3.5 Roadside Vending Sites.....	28
3.6 Heavy Vehicle Interception Sites.....	29
3.7 Queensland Police Service (QPS) Enforcement Bays.....	29
3.8 De-coupling Pads.....	30
3.9 Stockpile Management.....	30
3.10 Extraction Sites.....	32
4 Roadside Infrastructure	33
4.1 Road Furniture.....	33
4.1.2 <i>Signs, markings and delineation</i>	33
4.1.3 <i>Poles</i>	34
4.1.5 <i>Supports for road signs</i>	34
4.1.6 <i>Fences</i>	34
4.2 Road Lighting.....	35
4.3 Emergency / Help Telephones.....	35
4.3.1 <i>General</i>	35
4.4 Off-street Parking.....	36

4.4.1	<i>Introduction</i>	36
4.4.5	<i>Car parking area layout design</i>	36
4.4.9	<i>Verge and indented parking design</i>	37
4.5	Utilities	40
4.5.1	<i>General</i>	40
4.5.2	<i>Industry codes of practice</i>	41
4.5.3	<i>Allocation of space</i>	42
4.6	Intelligent Transport System Infrastructure	46
5	Roadside Environment Safety Considerations	47
5.1	Animal / Vehicle Collisions	47
5.2	Bushfire Risk Planning and Design	47
	References	50

Tables

Table 6B-1	– Rest area standards and facilities	19
Table 6B-2	– Indicative depths of underground utility infrastructure	44

Figures

Figure 6B-3	– Typical arrangement of glider pole and launching arms	3
Figure 6B-4	- Example of sodic / dispersive soils in table drains and cut batters	4
Figure 6B-5	- Undermining of road asset by erosion of sodic / dispersive soils	4
Figure 6B-6	– Passenger vehicle stopping place typical dimensions	12
Figure 6B-7	– Heavy vehicle stopping place typical dimensions	12
Figure 6B-8	- An economical reseal of an old alignment provides a new rest area with a large capacity	15
Figure 6B-9	– Locating rest areas adjacent to service centres	16
Figure 6B-10	– Rural rest area 14 km north of Surat on Carnarvon Highway provides shade, shelter, table and water	24
Figure 6B-11	– Environment providing for a medium number of heavy vehicles with basic facilities ...	24
Figure 6B-12	– Environment providing for a small number of heavy vehicles with basic facilities	25
Figure 6B-13	- Rest area in a medium volume and mixed traffic location	25
Figure 6B-14	- Environment providing for both heavy vehicles and tourist traffic	26
Figure 6B-15	– Dual-use rest area design	27
Figure 6B-16	– Simple duplicated rest area designs can remove the need for expensive turning lanes	28
Figure 6B-17	– QPS enforcement bay requirements	30
Figure 6B-18	– Example cross-section and layout for verge car parking	38
Figure 6B-19	– Example cross-section for indented car parking	39

2 Environmental Aspects

Addition

The Transport and Main Roads *Environmental Processes Manual* describes the environmental assessment and management process for transport infrastructure projects undertaken by the Department of Transport and Main Roads.

A major output from this process is recommended design measures to avoid and mitigate the identified environmental impacts. Where it is not possible to follow the recommended design measures, the Transport and Main Roads *Environmental Processes Manual* also includes processes for recording why the recommended design measure was not included and what alternative has been used.

2.1 Stormwater Run-off

Addition

Transport and Main Road's *Road Planning and Design Manual (RPDM) Edition 2: Volume 3 Supplement to Austroads Guide to Road Design, Part 5 Drainage – General and Hydrology Considerations, Part 5A Drainage – Road Surface, Networks, Basis and Subsurface, and Part 5B Drainage – Open Channels, Culverts and Floodway Crossings*, give further guidance on a multi-disciplinary approach to the provision of drainage infrastructure in the planning, design, operation and maintenance of road drainage infrastructure.

2.1.1 Drainage considerations

Addition

Drainage design also needs to consider changes to runoff rate and volume to receiving waters. Significant increases in the runoff rate and/or volume from a site to a receiving water can result in increased velocities, bed and bank erosion, loss of habitat and de-stabilisation of the riverine environment.

Further guidance on drainage considerations is available in the Transport and Main Roads *Road Planning and Design Manual (RPDM) Volume 3 Part 5 Drainage – General and Hydrology Considerations, Part 5A Drainage – Road Surface, Networks, Basis and Subsurface, and Part 5B Drainage – Open Channels, Culverts and Floodway Crossings*.

2.1.3 Erosion control

Addition

Further guidance for the planning and design of erosion and sediment controls are provided in the Transport and Main Roads *Road Planning and Design Manual (RPDM) Volume 3 Part 5 Drainage – General and Hydrology Considerations, and Best Practice Erosion and Sediment Control (IECA Australasia, 2008)*.

2.2 Fauna Management

Addition

The Transport and Main Roads *Fauna Sensitive Transport Infrastructure Delivery Manual* (FSTIDM) includes information on the road design features that can avoid and mitigate impacts to fauna.

The FSTIDM describes the following hierarchy of controls when dealing with fauna impacts:

- a) Avoidance: Can the sensitive area or important ecological feature be sufficiently avoided to result in no impact?
- b) Minimisation: If the sensitive area or important ecological feature cannot be avoided, can the potential impact be reduced through design, such as a reduced clearing footprint, realigning the project, or moving interchanges or overtaking lanes to another location?
- c) Mitigation: For impacts that are unable to be avoided or minimised, can design features be added to reduce the impact?

2.2.2 Fauna crossings

Addition

In addition, designers should refer to the Transport and Main Roads *Fauna Sensitive Transport Infrastructure Delivery Manual*.

Road design should include a consideration of local and regional habitat connectivity, including consideration of how barriers and/or noise fencing impacts the likelihood of fauna crossing a road. Where maintenance of habitat connectivity is desirable, the design should recognise that concrete safety barriers and noise barrier fencing do not allow passage of terrestrial fauna across the road and design specifications should be considered to rectify any decrease in connectivity.

Culverts – fish passages

Sections 3.3.7 and 5 of the Transport and Main Roads *Road Planning and Design Manual* (RPDM) Volume 3, Part 5 *Drainage – General and Hydrology Considerations* provide guidance on fish passage considerations.

For box culverts, designers should refer to Standard Drawings 1270 and 1271 for fish passage designs in accordance with the *Accepted Development Requirements for Operational Work that is Constructing or Raising Waterway Barrier Works*.

For construction and maintenance works on drainage structures, other than box culverts, located on the Queensland waterways for waterway barrier works spatial mapping, the following statutory documents provide requirements for structures to facilitate fish passage:

- *Accepted Development Requirements for Operational Work that is Constructing or Raising Waterway Barrier Works* – constructing or raising of waterway barrier works, and
- *State Development Assessment Provisions* (SDAP) *Guideline Code 18* – constructing or raising of waterway barrier works stipulates requirements for structures to facilitate fish passage.

General principles of fish passage design of drainage structures:

- attempt to mimic the hydraulic conditions of the natural waterway within the drainage structure (i.e., velocities, water depths)
- bury the base of culverts to enable infill of natural bed substrate to provide natural roughening and hydraulic conditions, and
- where design velocities are excessive for fish passage for significant proportion of flows, baffles can be installed to facilitate fish passage during high velocities.

Figure 6B-3 – Typical arrangement of glider pole and launching arms

2.2.5 Environmental offsets

There is no equivalent Section 2.2.5 in Austroads *Guide to Road Design – Part 6B*.

New

For some road corridors and projects, it may be necessary to establish environmental offset areas 'offset' to impacts incurring from the infrastructure projects. These offset areas are typically regulated by legislation and must be formalised and documented in accordance with Transport and Main Road's *Environmental Offset Policy* (note this publication is for Transport and Main Roads internal use only and not for external distribution).

Where environmental offsets exist within the proposed footprint of a project, project planning and design needs to avoid and mitigate impacts to offsets or establish replacement offset areas.

2.3 Noise Control

2.3.1 General

Addition

Designers should also refer to the Transport and Main Roads Technical Specification MRTS15 *Noise Fences*, and the *Transport Noise Management Code of Practice* and associated Technical Notes.

2.3.3 Noise barriers

Addition

Designers should also refer to the Transport and Main Roads Technical Specification MRTS15 *Noise Fences*, and the *Transport Noise Management Code of Practice* and associated Technical Notes.

The design life of noise fences, for the purpose of strength, serviceability and stability calculations shall be 40 years. The design life for any connections to bridge and retaining walls shall be 100 years. The minimal maintenance-free life of the main construction materials other than protective coating shall be 25 years.

2.4 High Risk Soils

There is no equivalent Section 2.4 in Austroads *Guide to Road Design – Part 6B*.

New

Soil sodicity is a natural feature of many Queensland soils, with approximately 45% considered sodic (dispersive). These soils present considerable risk to road assets and if not appropriately managed, in planning, design, construction and maintenance phases, can have considerable impacts to the local waterways, receiving environments and road infrastructure.

Other soils, such as acid sulfate soils that exist in low lying coast areas and saline soils, are also considered high risk.

Designers should refer to the Transport and Main Roads Technical Specifications MRTS04 *General Earthworks* and MRTS16 *Landscape and Revegetation Works*.

Figure 6B-4 - Example of sodic / dispersive soils in table drains and cut batters



(Source: Darling Downs District)

Figure 6B-5 - Undermining of road asset by erosion of sodic / dispersive soils



(Source: Wide Bay Burnett District)

Technical Note 208 *Managing Slaking and Dispersive Soil risks in transport infrastructure projects* is a critical tool providing guidance on the management and treatment of these problematic soils at all project stages. Assessment of these problem soils are included in environmental and geotechnical assessment processes. Design treatments offer the most effective mitigation measures for these soils, with further management strategies incorporated into Contract documentation.

Managing impacts

Once problem high risk soils have been identified, the design process should consider the hierarchy of management – avoid, mitigate, minimise, and manage.

Roads are typically unable to avoid high risk soils due to their widespread existence. Common design considerations for problem high risk soils include:

- Vertical alignment:
 - Whether it would be possible to avoid disturbance of problem soils by building embankment above the surrounding ground level, thereby avoiding cutting in drainage paths, and
 - Whether cut batters and fill batters will present erosion risks that can be reduced by modifying vertical alignment.
- Amelioration:
 - Soil impacts can be treated with ameliorants, such as gypsum and lime.
- Zoned embankment:
 - In some situations, problem soils can be encapsulated within a zoned embankment.
- Diversion of water from the ground surface:
 - Where possible, the design should minimise the amount of water flowing over soils that are high risk of erosion. Design could include:
 - diversion of upslope water
 - channelised flow in protected drainage lines, and
 - steepening of cut batters to lessen the surface area exposed to rainfall.
- Armouring considerations should include:
 - Hard armouring (permanent erosion and sediment controls):
 - Hard armouring of cut and fill batters in problem soils can protect against instability and environmental impacts, and
 - It is essential that the surface is ameliorated prior to installing the hard armouring treatment, as per MRTS16 *Landscape and Revegetation Works* subsoil requirements, even though the area is not being vegetated, as this will reduce the risk of any flows at the subsoil / hard armour interface, undermining the treatment.

- Soft armouring:
 - Revegetation of problem soils is very important for the long-term stability of the roadside environment. Revegetation alone is not commonly an effective treatment for problem soils. Revegetation needs to be combined with another treatment such as amelioration, and
 - Revegetation of high-risk soils should include rapid establishment of ground cover through the use of annual (cover crop) and perennial grasses; and other ground cover species followed shortly by pioneer native shrub species establishing on site. Species selection for erosion protection should be prioritised over selection for biodiversity to minimise soil loss, maximise surface stability, and increase the potential for diverse species to establish over time.

Inclusion of the soil and vegetation treatment methodology(s) based on the pre-construction risk assessment of the project soils, in contract documentation, is essential for ensuring that soils are adequately addressed during construction to avoid legacy issues during operational phase.

2.5 Contaminated Land

There is no equivalent Section 2.5 in Austroads *Guide to Road Design – Part 6B*.

New

Where contamination is identified as part of project planning processes and assessments, the designer is to consult with a Suitably Qualified Person qualified in contaminated land (as defined in the *Environmental Protection Act 1994*) to determine contamination management requirements for design, construction, operation, and maintenance of the road in order to prevent and mitigate any impacts to the roadside environment.

2.6 Cultural Heritage Aspects

There is no equivalent Section 2.6 in Austroads *Guide to Road Design – Part 6B*.

New

Designers should refer to the Transport and Main Roads *Cultural Heritage Organisational Policy* and *Cultural Heritage Process Manual*. A copy of the *Cultural Heritage Process Manual* can be obtained from the Manager (Cultural Heritage & Native Title) at TMR.Heritage@tmr.qld.gov.au. It is recommended that departmental District Cultural Heritage Officers are engaged by designers to provide advice on cultural heritage constraints via an Environment and Heritage Service Request (ENV01) in the first instance.

When a road design may impact areas of known or potential cultural heritage significance (for example, heritage-listed places or Aboriginal sites) as identified via a Cultural Heritage Risk Assessment (CHRA), the design must recognise the need to avoid or minimise harm to these places. Departmental Cultural Heritage Officers will provide guidance and advice in these instances.

3 Roadside Amenity

3.1 Urban and Regional Design

Addition

Further details on the department's requirements on urban and regional design are outlined in the Transport and Main Roads *Road Landscape Manual, Movement and Place Policy, Movement and Place Practitioner Guidance*, and TransLink *Public Transport Infrastructure Manual*.

3.2 Visual Amenity

Addition

Further details on the department's requirements on visual amenity are outlined in the Transport and Main Roads *Road Landscape Manual*.

3.3 Landscaping

Addition

Details on the department's requirements on landscaping are outlined in the Transport and Main Roads *Road Landscape Manual*.

3.3.2 Safety

Addition

The design of landscaping must also consider the practice of 'Crime Prevention through Environmental Design' as described in the Transport and Main Roads *Road Landscape Manual*, and the *Crime Prevention Through Environmental Design Guidelines for Queensland*.

3.3.3 Design considerations

Addition

Details on the department's requirements on landscaping design considerations are outlined in the Transport and Main Roads *Road Landscape Manual, Movement and Place Policy*, and *Movement and Place Practitioner Guidance*.

The soil type, bush fire risk, erosion risk and proximity to receiving environments should be considered when designing landscaping and revegetation. High risk soils, that are to be vegetated, typically need to be ameliorated prior to landscaping. Details on the department's requirements on high risk soils are outlined in MRTS04 *General Earthworks* and MRTS16 *Landscape and Revegetation Works*.

The design of project should consider the provision of shade to pedestrian oriented spaces in accordance with Technical Note TN197 *Provision of shade along paths*.

Difference

The maintenance implications of road landscape designs are important factors in achieving a successful and sustainable landscape scheme.

Access requirements of maintenance crews and equipment for vegetation control and maintenance of road and drainage structures must be provided to ensure the safety of the crews while undertaking their tasks.

In addition, the proximity of plantings to the pavement, structures and underground services can result in damage. To guard against damage, all trees installed within 3 m of the road pavement, structures or underground services should incorporate a root barrier system to limit potential damage to infrastructure. Further, tree species with buttressing or damaging root systems should not be used near the road pavement, structures or underground services (for example, fig trees).

3.3.4 Landscaping specific situations

Addition

Rest areas

The design of rest areas must also consider the practice of 'Crime Prevention through Environmental Design', as described in the Transport and Main Roads *Road Landscape Manual*, and the *Crime Prevention Through Environmental Design Guidelines for Queensland*.

Addition

Vegetation adjacent to services

Underground services – where trees are proposed within 4 m of an underground service, root barriers should be provided to mitigate the potential impacts of roots on the service. Where a root barrier is installed, a tree may be within 1.5 m of an underground service. Tree species with buttressing or damaging root systems should not be used near underground services, including where a root barrier is provided (refer to underground service provider guides for further guidance).

Addition

Medians and splitter islands

Planting within medians can also:

- help prevent U-turns in locations where a safety barrier is not present.

Interchanges

Interchanges often have large areas within and surrounding that offer opportunities to revegetate or provide more formal vegetation arrangements depending on context. Within large interchanges:

- Mass planting of trees and shrubs should be considered outside hazard-free areas and sight visibility requirements to eliminate regular maintenance requirements within interchanges. Planting container stock in these situations is preferable to seeding operations to ensure vegetation and associated outcomes are achieved, and
- In urban areas, turf should be considered where a grass outcome is required to provide immediate surface protection and minimise establishment and associated traffic control requirements. Turf is preferable to seeding operations to ensure erosion and sediment requirements are met and associated design and maintenance outcomes are achieved.

Pedestrian and cyclist facilities

To reduce heat and UV exposure:

- where practicable outside of hazard-free areas and sight visibility constraints, trees should be provided at regular intervals to provide shade to users of the facilities.

The design of project should consider the provision of shade to pedestrian orientated spaces in accordance with Technical Note TN197 *Provision of shade along paths*.

Urban roads

The design of urban roads should consider the Transport and Main Roads *Road Landscape Manual, Movement and Place Policy, Movement and Place Practitioner Guidance*, and the provision of shade to pedestrian orientated spaces in accordance with Technical Note TN197 *Provision of shade along paths*.

3.4 Rest Facilities

Addition

The information in Section 3.4 of Austroads *Guide to Road Design – Part 6B* is accepted as providing an overview of the issues relating to rest facilities. Additional design guidance is provided in this supplement.

3.4.1 Need for rest facilities

Addition

On rural roads rest areas are to be provided every 80 km.

3.4.2 Road design considerations for rest areas and service centres

Difference

The rest area categories (major rest areas, minor rest areas, truck parking areas and motorist stopping places) described in this section of Austroads *Guide to Road Design – Part 6B* are replaced with the definitions below for:

- Formal rest area network:
 - rest areas (Types A, B and C for both light and heavy vehicle categories)
 - driver reviver sites (generally this will be at Type A sites), and
 - stopping places.
- Informal rest opportunities:
 - interception sites, and
 - informal heavy vehicle stopping places.
- Commercial rest opportunities, and
- Towns as rest opportunities.

Addition

The information in Section 3.4.2 of Austroads *Guide to Road Design – Part 6B* is accepted as providing an overview of the issues relating to road design consideration for rest facilities. The following guidance should be applied for the road design considerations for rest areas and service centres in Queensland.

In order to ensure consistency when developing or upgrading rest areas, definitions have been developed that will allow officers to design new sites to standards that meet identified needs. These standards will also allow officers to assess existing sites against desired standards and develop upgrade programs.

The functional requirements of rest areas differ according to location, vehicle mix, and desired user type. Traffic volumes at each location will determine capacity requirements, however, rest areas can generally be categorised as follows:

- *Type A*

Sites providing extensive facilities supporting all potential motorist types including those wishing to utilise the site for limited camping opportunities (for motorist sites). These sites are generally 'mid-block' and do not conflict with commercial or civic sites within the area.
- *Type B*

Sites focussed on providing an appropriate number of parking bays with facilities intended to cater for short to medium term rest periods in support of achieving rest during journeys. These sites represent the standard site provided by Transport and Main Roads, do not conflict with commercial or civic sites, and provide a standard level of fatigue-related facilities on the State-Controlled Road Network (SCRN), and
- *Type C*

Sites providing locations with an adequate number of parking bays at which motorists can safely stop away from the roadway in order to rest. Facilities may be minimal, potentially including only hardstand areas, bins and shade. These sites are provided where fatigue-related facilities are required without the need to provide a greater level of facilities. These sites may include those that are adjacent to commercial or civic facilities, or support roads with low vehicle numbers for the appropriate vehicle type.

Due to the differing functional requirements of heavy vehicle drivers and other vehicle types, it is important to differentiate between motorists and the needs of heavy vehicle drivers who may also be impacted by fatigue management legislation requirements.

The design of every rest area will have a particular set of requirements defined by its location, road type, and usage, and many other local requirements. The importance of the knowledge and experience of local Transport and Main Roads officers, industry, and road users cannot be overstated, and each area should be carefully considered and include appropriate consultation to ensure all needs are met.

Access and egress must accommodate the traffic likely to use a site and must provide an adequate level of safety for vehicles entering or leaving the rest area.

The application and requirements will vary from site to site and should consider at least the following:

- Access arrangement (turning movements):
 - On all dual carriageway roads:
 - Accesses to the rest area are to be restricted to left-in / left-out access for all road users.
 - Rest area facilities should be duplicated (one rest area on each side of the road). Pairs of rest areas do not have to be directly opposite each other and in some cases may be staggered to achieve improved safety outcomes, and
 - Where duplication is not possible, appropriate intersection design should be applied as per RPDM Volume 3, Parts 4, 4A, 4B and 4C.

- On single carriageway roads:
 - The need for duplication of rest area sites is dependent on the volume of traffic, the type of vehicles using the route, and the availability of safe right-turn opportunities into and out of the site, and
 - Where vehicles would have difficulty crossing into a rest area or movements across a road would interfere with the normal flow of traffic causing safety concerns, the need for duplication is increased. Duplication of sites may also reduce the need for safety treatments, such as protected right-turn lanes on the road itself, and can be an economical solution.
- A left-in / left-out design, duplicated on both sides of a road, has the potential to provide surety of safety through the minimisation of turning manoeuvres by large vehicles and provide more space for drivers without excessive costs in associated road works, and
- Acceleration and deceleration lanes – where required, adequate acceleration and deceleration lanes should be provided at the exit and entrance of rest areas as per RPDM Volume 3, Part 4A. Locating rest areas at the top of crests assists in reducing the need for and length of these lanes.
- Access to service centres:
 - Direct access to a motorway or grade separated highway is preferred over indirect access due to the potential heavy traffic flows on interchange ramps. The location of service centres must consider the minimum spacing between adjacent ramps as detailed in RPDM Volume 3, Part 4C. For an otherwise high-class proposal, consideration may be given to a reduction in this distance provided expert traffic engineering analysis can demonstrate adequate safety and operational performance, and
 - Indirect accesses at interchanges may be permitted but will require expert traffic engineering analysis of the impact on the operation and safety of the ramps and intersections involved. Such access is not preferred because it is not as easy for drivers to stop. Indirect access will be considered where alternatives are not available, or the site and development proposal clearly offer the best solution in all other respects.
- Grade (of the road at the rest area location) – heavy vehicle drivers prefer rest areas located at tops of hills with up-grade access into the rest area and a down-grade exit. Uphill exits are undesirable for trucks and may lead to trucks stopping on the road shoulder nearby, instead of using the rest area.
- Topography – locations in deep gullies, rolling hills or high cuttings should be considered inappropriate when selecting rest area sites due to difficulties in addressing requirements for grade, access arrangements, and internal rest area grades.

- Design vehicle – the ingress and egress to each rest area should be suitable for the largest combination vehicle utilising the route. The design and check vehicle appropriate for the route should be adopted for the design of access and egress from rest areas, and
- Sealed access – access into the rest area should be sealed to enable safe entry and exit. On unsealed roads, access points should conform to the conditions of the roadway. The access and egress should be designed to ensure that maintenance issues resulting in rough or damaged access points are avoided to prevent difficulty for vehicles entering and exiting the site and safety concerns for the drivers and other road users.

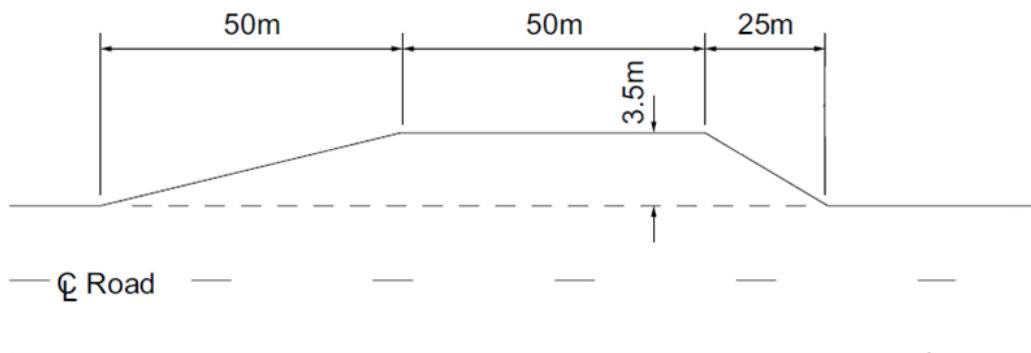
Motorist stopping places

The signage arrangements for motorist and heavy vehicle roadside stopping places are shown in the Transport and Main Roads *Traffic Control (TC) Sign TC1112*.

Typical dimensions for passenger vehicle and heavy vehicle stopping places are shown in Figures 6B-6 and 6B-7. The surfacing of the stopping place is to be consistent with the surfacing of the adjacent road.

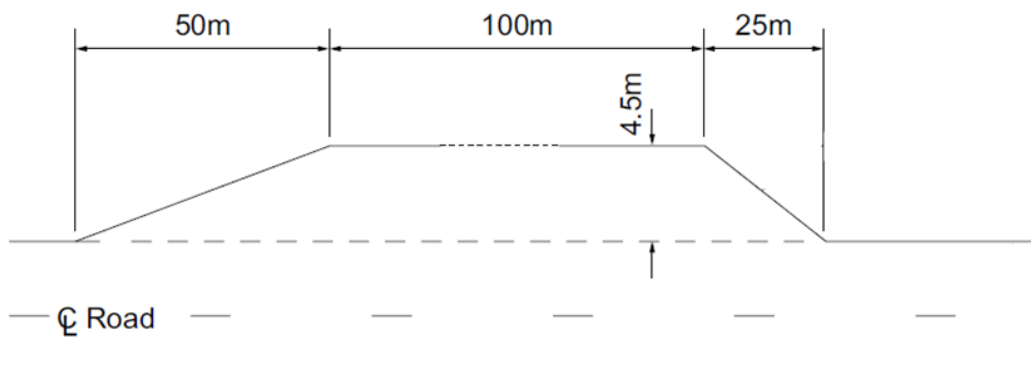
On rural roads stopping places are to be located every 30 km.

Figure 6B-6 – Passenger vehicle stopping place typical dimensions



NOT TO SCALE

Figure 6B-7 – Heavy vehicle stopping place typical dimensions



NOT TO SCALE

3.4.3 Siting of service centres and rest areas

Addition

High-level strategic analysis of the network will identify broad locations at which establishment of new rest areas is desirable however there are many local factors that will influence the final on-the-ground placement of the site itself.

At the route level, it is important to consider all relevant issues that may impact on the effectiveness of each rest area and its purpose of supporting fatigue outcomes.

The final actual location of a rest area site can be identified based on preferences of features that the local conditions naturally provide, such as grade, natural shade, availability of utilities, and the geometric and environmental constraints of the site, as well as accompany road configurations.

The following lists some factors that assist in identifying preferable rest area locations:

- Rest areas should be located within safe access to the road, while also providing sufficient separation for both safety and rest purposes. Separation is a key element in providing effective rest, and screening from the road corridor should be provided, particularly for areas used at night, to allow drivers to sleep without disturbance from headlights moving along the adjacent roadway.
- Better utilisation can be expected from sites with clear visibility of facilities, and adequate internal signage. At the same time, maintaining sufficient separation from the road as to facilitate rest often provided through screening using vegetation continues to be important.
- Straight sections of road with good sight distances are preferred. This will enable heavy vehicles improved access and egress when leaving or re-entering traffic flow. Heavy vehicle drivers prefer rest areas located at tops of hills with up-grade access into the rest area and a down-grade egress. If this cannot be achieved, the grade when re-entering the road should be as flat as possible.
- Flat areas are highly important for heavy vehicle parking in rest areas. Long haul heavy vehicle drivers who take long rest breaks need a level surface in order to enable sleeping in the heavy vehicle cabin without disturbance through discomfort.
- Heavy vehicle drivers require stopping and rest opportunities on the approach to and departure from urban centres, such as Brisbane and major towns. This enables heavy vehicle drivers to check loads and security, and to rest on the approach to these towns so that they arrive at unloading facilities or depots at the appropriate time and adequately rested to participate in necessary unloading activities.
- Areas that provide shade are highly desirable for rest areas. Shade is important for drivers travelling in summer months, particularly in the hotter western areas of the state. Natural shade is preferred as it can be utilised to protect the vehicle itself from the heat of the day. As such, as much vegetation as possible should be retained when designing / constructing sites.
- When choosing a site, close proximity to utilities such as water, sewerage, and electricity is desirable, as this reduces the cost of building and operating the rest area, as well as improving the quality of services for drivers.
- In more remote areas, the use of composting toilets and water tanks is becoming more common in order to provide facilities at lower expense. For safety purposes, solar lighting is also being used in many rural / remote Queensland areas.

- Lighting for security or safety may be provided where appropriate. Availability will depend on access to services, however, in remote areas solar lighting is being used successfully. Lighting should be maintained at a safe level but should not be so bright that it would disturb sleep. For example, flag lighting, maintained at a level suitable for pedestrians and located only around available facilities, may be appropriate in many circumstances.
- Potential locations for rest areas should undertake environmental assessments as required to ensure environmental impacts are minimised.
- It is important to consider proximity of the site to domestic homes or developments, institutions, or businesses in the area. Particularly in rural settings and locations where noise can travel unimpeded for long distances, it has been known for the arrival and departure of heavy vehicles on a site to cause disturbances to homes 1 km or more away. Conversely, a local activity, such as a feed lot or piggery, can cause noise at night that may disturb the driver's ability to rest effectively, and
- You will also need to consult the Transport and Main Roads *Conservation Land Assets (CLA) Framework*. The CLA Framework ensures areas with significant ecological / environmental values, unique environmental character / features or special conservation characteristics within government supported transport corridors or assets are appropriately managed and given consideration in all aspects of Transport and Main Roads business. The purpose of the CLA Framework is to ensure the long-term protection or improvement of the values or characteristics of the CLA Framework. This may require special management or atypical maintenance practices to ensure the long-term viability of the CLA Framework.

Other local considerations or constraints, such as native title issues, size of available corridor, regional planning requirements, and local council issues, will also impact on the final location of a site within the required general area.

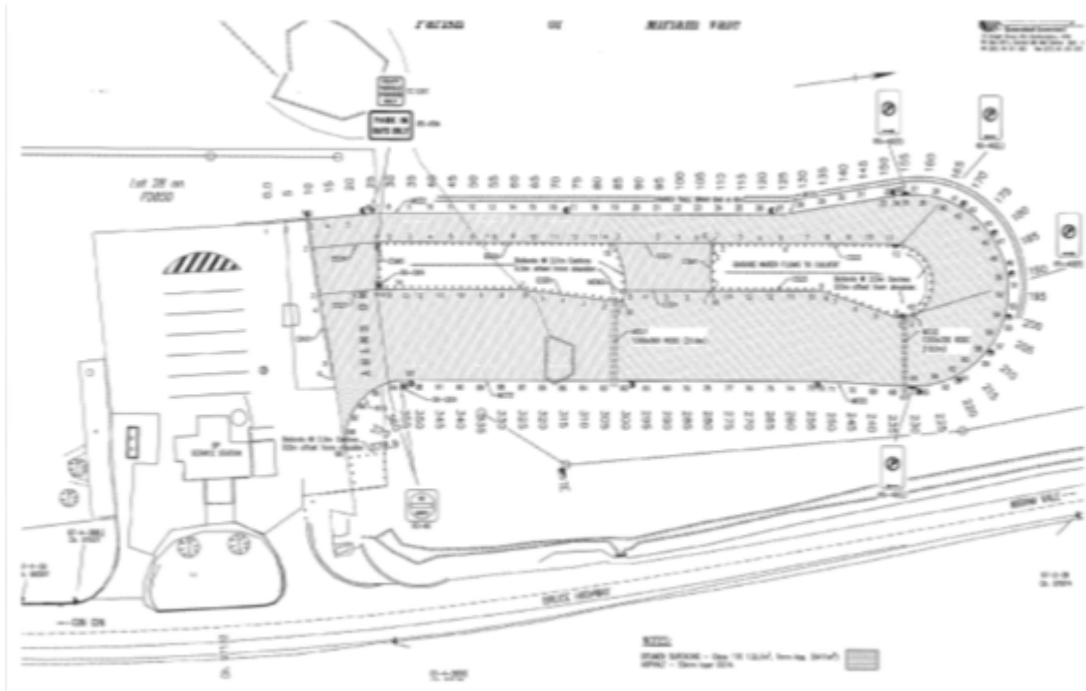
Methods for providing rest areas in an economical manner include:

- Use of segments of old road alignments that would otherwise not be utilised. These segments can be used to create a large and long heavy vehicle rest area at a significantly reduced cost. The realignment of an existing road should consider the opportunities to use redundant sections of road alignment as rest areas. An example at Colinton on the D'Aguilar Hwy west of Kilcoy is illustrated below in Figure 6B-8. It provides a significant area for nose-to-tail parking, safe access to tables, shelters, and toilets, and is located opposite a roadside service station to provide access to food and services. Due to the existing old alignment, a simple spray seal surface was all that was needed, making this an effective and economical solution.

Figure 6B-8 - An economical reseal of an old alignment provides a new rest area with a large capacity



- Co-placement of rest areas with commercial operations such as service stations is an effective way to minimise ongoing costs and provide drivers with enhanced facilities such as access to food, water and shelter in a secure environment. The example in Figure 6B-9 allows for effective utilisation of existing land. This method also reduces the cost of implementation as the entry / exit to the site is via the existing service station, thus eliminating the need to provide these facilities specifically for the rest area, and
- Location of rest areas within towns.

Figure 6B-9 – Locating rest areas adjacent to service centres

Please note that the document titled 'A Proposed Heavy Vehicle Rest Area Needs and Prioritisation Methodology' (Austroads 2012a), as referenced in the Austroads Guide, has been superseded. For the most current version, please refer to the Austroads website.

3.4.4 Design of service centres and rest areas

Difference

Figure 3.4 in Austroads *Guide to Road Design – Part 6B* which is an illustration of a rest area layout is not to be used. Instead, the sample layouts below should be consulted.

Addition

In addition to the requirements in Austroads *Guide to Road Design – Part 6B*, the design of services centres and rest areas should include consideration of the following.

The design of rest areas should be prepared in coordination with urban design, landscape and environmental design disciplines to ensure the integration of all the various elements of the design. As any rest area could potentially be considered part of the commercial driver's work area, workplace health and safety considerations may apply. It is therefore essential that rest areas allow activities that commercial vehicle drivers may be required to undertake in a safe manner.

The design guidance contained in this section does not apply to decoupling sites or sites where freight related activities occur, and these sites should be clearly separated from rest areas.

The internal design of every rest area will vary dependent on its location, road type, and usage, and many other local requirements. The importance of the knowledge and experience of local departmental officers, industry, and road users cannot be overstated, and each area should be carefully considered and include appropriate consultation to ensure all needs are met.

Proposed layout

The design of a rest area will be strongly influenced by the local conditions and the route on which it is placed. There is no single 'template' design for rest areas, however, there are common features. The most important consideration when designing a rest area is to ensure safety of movement within the site, and to minimise potential conflicts between vehicle and pedestrian movements.

The design of parking areas within the rest area should allow for the following:

- Adequate parking for the types and number of vehicles using the area. As a minimum, rest areas must provide 4-6 parking bays per vehicle type accessing the site.
- The provision of a combined motorist and heavy vehicle rest area is sometimes appropriate to allow greater use of shared amenities and greater economies of scale. Motorists and heavy vehicle rest area users can share the facilities in combined rest areas.
- In combined rest areas, heavy vehicle parking spaces should be separated from other vehicles to prevent traffic conflict during manoeuvring. The separation of motorist and heavy vehicle parking spaces reduces disturbance of heavy vehicle drivers' rest by holiday or other travellers. Landscaped areas or sound absorbing walls can be used for separation.
- Heavy vehicle bays are to be designed as 'front-to-rear' or 'nose-to-tail' parking. This allows heavy vehicles of various sizes to make the best use of the space available, and also provides easy manoeuvring in the rest area. It is also the most effective design layout for achieving effective rest as it minimises in-cabin noise impacts for drivers when using their sleeper cabs.
- Separate the heavy vehicle parking area into different parking areas for short-term and long-term heavy vehicle parking to minimise disturbance to those who require long rest breaks.
- Allow for the use of all expected vehicle types and, where possible, separate them within the rest area.
- Provide an adequate number of larger and longer bays for caravans and recreational vehicles, and
- When providing heavy vehicle spaces in rest areas, allow for the design and check vehicles for the route (refer to RPDM Volume 3, Part 4 for a description of the design and check vehicles).

Rest area safety

Rest areas should be designed to ensure the safe movement of all users potentially accessing the site. Internal movements should be managed or directed to ensure they are at a safe level and that the potential for conflict between all users is minimised.

Interaction between vehicles and pedestrians, in particular, when accessing facilities provided, should be minimised, and any necessary interaction should occur at a very low speed.

When deciding on placement of facilities and parking bays in dual-use areas, there is potential for very large trucks and pedestrians (including children) to interact. When designing for pedestrian / vehicle interactions, the following should be considered:

- parking areas should be located immediately adjacent to facilities
- access roadways should not be located between facilities and car parking areas

- roadways designed for vehicle acceleration or deceleration between the highway and the rest areas should not intersect with a location or path a pedestrian is likely to utilise
- clear lines of sight, particularly around facilities and pedestrian access points, should be achieved, and
- at very large or busy facilities, it may be necessary to implement formal pedestrian facilities (marked crossings, etc.) in accordance with RPDM Volume 3, Part 4.

Surface grade

A level surface in a rest area is desirable. Long distance drivers who take long rest breaks need a level place to enable effective sleeping within the vehicle or heavy vehicle cabin.

Safe movement within the site

The circulation of vehicles in the rest area should minimise internal traffic conflicts. For example, a good rest area layout design should ensure uni-directional flow of vehicles entering, parking, and exiting the rest area. Rest areas should be designed so that reverse manoeuvring of heavy vehicles is not required.

The layout should ensure that the design vehicles can negotiate the rest area without being impeded by other parked vehicles.

Separation of vehicle types

Separation of vehicle types should be considered where interactions between them could have safety implications. As a rule, motorists should be separated from heavy vehicles wherever possible, particularly in highly trafficked areas where vehicle interactions may be intensified. This is particularly important in areas where children may have access to areas in which heavy vehicle manoeuvres might occur.

Even amongst heavy vehicles, livestock and refrigerated vehicles are known to cause disturbance to drivers of other vehicle types, and, where possible and practicable, should be provided with separated areas to park so as to minimise noise related impacts on other drivers attempting to achieve effective rest.

If the site caters for heavy vehicles, it should also provide:

- separation between short- and long-term parking areas to allow drivers on 'long breaks' to sleep without disturbance
- possible separation between types of heavy vehicles, such as those carrying livestock or dangerous goods
- nose-to-tail parking for heavy vehicles to allow for effective rest with reduced near-cabin noise issues
- significant shade, particularly in western areas subject to high summer temperatures, and
- sufficient parking bays and manoeuvring room designed for the largest combination permitted use of the route.

Dangerous goods vehicles may also need to be considered on routes where these vehicles are common. Due to safety requirements, they may not be able to stop at the same rest area as other heavy vehicles. For example, an explosives vehicle must not stop near a fuel tanker and will need to proceed to the next available rest area, or a dangerous goods vehicle must not park within 15 m of a building or a concentration of people and is also restricted to 8 m from another vehicle which is a placard load. This may be particularly important on significant freight routes which are known to support mining operations which require significant numbers of this type of movement.

In addition, if the route is a tourist route, consideration of a separated area for use by light vehicles camping overnight and other motorists. Noise impacts from short-stay motorists, particularly children, can impact on the fatigue management benefits of the rest area.

Where vehicle mix is an issue, clear line marking and signage should be erected to direct vehicles to an appropriate area within the site.

Amenity

A landscape buffer zone is essential to separate the road from the rest area and provide a more restful space. 7 or 8 m is a desirable minimum width for this zone, however, this may not be achievable in situations with limited corridor space. This must be balanced with the need, for safety purposes, that the rest area should not be hidden from view. To provide a perception of security, it should be laid out so it can be seen from the road. Ground cover combined with clear trunk trees can help provide both views and a feeling of separation. Where practicable, trees should be located to provide shade and amenity to users of the facility.

As an absolute minimum where a nature strip is not possible, separation should be clearly indicated by adequate and visible line-marking and fencing if appropriate for safety.

Pavement

The pavement within the rest area should be designed to cater for the largest and heaviest vehicles that are anticipated to utilise the site, and of sufficient quality to remain accessible in all weather conditions.

Facilities

In combined rest areas, amenities should be located within convenient access to both motorist and heavy vehicle drivers and passengers. For example, toilets should be located between the motorist and heavy vehicle parking areas or at a location that does not require motorists to enter the heavy vehicle parking area of the site.

The following Table 6B-1 defines the desired standards and facilities for each rest area type.

Table 6B-1 – Rest area standards and facilities

	Heavy Vehicle			Motorist		
	Type A	Type B	Type C	Type A	Type B	Type C
Capacity (for largest vehicle permitted on route)	Large: 15+ bays (>1000 HV AADT) Medium: 10-15 bays (500-1000 HV AADT) Small: 5-10 bays (<500 HV AADT)			Large: 20+ bays (>10,000 AADT) Medium: 10-20 bays (1000-10,000 AADT) Small: 5-10 bays (<1000 AADT)		
All weather seal	Yes	Yes	Gravel	Yes	Yes	Gravel
Separation for vehicle types	Yes	Desirable	Where possible	Yes	Desirable	Where possible

	Heavy Vehicle			Motorist		
	Type A	Type B	Type C	Type A	Type B	Type C
Separation for long term / short term visitors	Yes	Desirable	No	Yes	Desirable	No
Bins ⁽¹⁾	Yes	Yes	Yes	Yes	Yes	Yes
Natural shade / trees ⁽²⁾ (where available)	Yes	Yes	Yes	Yes	Yes	Yes
Tables / chairs ⁽³⁾	Yes	Yes	Yes	Yes	Yes	Yes
Shelters / artificial shade	Yes	Yes	Yes	Yes	Yes	Yes
Lighting ⁽⁴⁾	Yes	Desirable	No	Yes	Desirable	No
Toilets ⁽⁵⁾ and Water Supply ⁽⁶⁾	Yes	Desirable	No	Yes	Desirable	No
Separation from road	Well separated and screened with vegetation mounding, barrier etc.	Separated and screened where possible	Separated (as a minimum by line marking)	Well separated and screened with vegetation mounding, barrier etc.	Separated and screened where possible	Separated (as a minimum by line marking)
On-Road signage	Yes	Yes	Yes	Yes	Yes	Yes
BBQ	No	No	No	Yes	Where possible	No
Playground	No	No	No	Yes	Where possible	No
Private camping allowed (20 hr max)	No	No	No	Yes	As appropriate	No
Caravan dump point provided	No	No	No	Yes	Where possible	No

Notes:

1. Appropriately sized bins (preferably with lids) should be clearly visible, easily accessible, and serviced regularly.
2. Wherever possible, the maximum number of natural shade trees should be provided. Where these cannot be retained during construction works, replacement of shade trees is required. This is particularly important in hotter western areas of Queensland, and at heavy vehicle rest areas where larger, taller trees ensure drivers can rest comfortably over longer periods of time when they have no access to air conditioning.
3. Tables, chairs and shelters – a standard 6-seater 'BBQ-style' table / chair set covered by a solid roof providing shelter from both sun and rain is the minimum standard required for all rest areas. The number and size of shelters is dependent on expected usage of the rest area. Where natural shade is not available, it is important to provide larger areas of artificial shade that is available at all times of day, and shade-providing walls may be required for shelters where trees are not available.
4. Lighting – lighting is useful to enhance personal safety of rest area users. Not only will lighting aid security to those using the site, but it will act as a beacon to improve the visibility of the rest area from the road. This will promote its use and also improve the perceived safety of users as they know they are visible to passers-by. Lower-level lighting should be provided in designated parking areas to allow drivers the opportunity to take long sleep breaks.

5. Toilets – where sewers are located in close proximity to the rest area, toilets should be connected to the sewerage system.

Where a sewer is not available, the selection of toilet type and toilet designs requires knowledge of estimated rest area usage. Composting toilets should not be used for high volume roads where rest area usage is significant. Septic tank systems and Aerated Wastewater Treatment System (AWTS) can be installed to treat wastewater to the required level of effluent quality for discharge. Attention must be given for sensitive land use if effluent needs to be discharged for land applications.

Toilet designs should be simple, durable, and vandal-resistant to enable easy maintenance and minimise the whole of life cost. The selection and design of rest area toilets should take into consideration the ongoing maintenance of the facility required.

Ventilated toilet designs should be used to minimise odour problems. The roof of a toilet structure can be designed such that it maximises natural lighting for energy savings and provides good ventilation, and

6. Water supply – if town water is available at the rest area site, it should be provided for use. Potable water should be provided where practicable for hand washing, with appropriate signage used where the water is not suitable for drinking. As a preferred minimum standard, a tank should be supplied where there is capacity to collect water (for example, where a shelter-shed is provided).

Animal welfare requirements

There may be a need to consider whether access to animal spelling yards will be required in order for drivers to meet not only their own fatigue management requirements, but also the welfare requirements of the animals they are transporting.

Safety and crime prevention through design

The design of safe built environments improves safety and security in rest areas. The site layout design should allow for easy identification of pedestrian corridors and destinations, establish clear sightlines through sensitive location of site features, and maximise the opportunities for natural light and pathways illuminated by lighting at night. A clear sight distance provides a perception of safety and adequate space.

Environmental impacts

The environmental assessment and design of a rest area should be undertaken in accordance with the Transport and Main Roads *Environmental Processes Manual*.

Rest areas should be designed to minimise environmental impacts. Particularly in rural and remote areas, the use of composting toilet facilities and solar lighting should be considered. Grass swales or vegetative strips between the rest area and roadway may be used to provide natural stormwater treatment for runoff from the road or rest area.

Rest areas can have associated biosecurity risks from weed seed dropping from vehicles and being transferred from people clothing and shoes. This is particularly a concern where livestock trucks are stopping. Consideration should be given to whether the site could be drained to a detention basin or sump where weed seed can be collected and controlled. This area should then be maintained for weed management to prevent introduction of weed species.

Illegal dumping of waste can be a concern at rest areas. Restrictions of vehicles to paved areas only can assist in preventing illegal dumping.

Landscape design

Landscaping and provision of trees and plants should be considered early in the design of rest areas to ensure adequate shade provision, protection from noise, and screening from traffic on adjacent roads. Wherever possible, the maximum number of natural shade trees should be provided throughout the rest area. Retention of existing trees should be prioritised where practicable during design and construction. Where trees are removed, they should be replaced with the intent of achieving a similar canopy and shade coverage in the future. This is particularly important at heavy vehicle rest areas where larger, taller trees ensure drivers can rest comfortably over longer periods of time. Landscaping should also consider if an area is bushfire prone, and landscape design should not exacerbate bushfire occurrence and should facilitate future bushfire management. The landscape design of a rest area should be undertaken in accordance with the Transport and Main Roads *Road Landscape Manual*.

Noise impacts

Impacts due to noise should be a strong consideration in the design of heavy vehicle rest areas in order to ensure:

- heavy vehicle drivers are provided the best opportunities available to achieve optimum rest or sleep, and
- that nearby properties are not exposed to excessive noise generated due to heavy vehicle movements or from equipment such as refrigeration units.

The physical design of a rest area can have significant noise impacts on users of the area. Designs where vehicles bays are configured in a side-by-side format can be more efficient in the use of space, and therefore less expensive to construct. However, they produce less desirable outcomes for fatigue management as the noise generated by vehicles starting and stopping in close proximity to each other (in particular, close to the cabin of sleeping drivers in adjacent bays) can cause sleep disturbance.

Nose-to-tail configurations produce less noise impacts for drivers, and are generally preferred by industry as there are generally less 'peak' noise events (stopping, starting, etc) occurring immediately adjacent to the cab of a resting driver. It is important when considering nose-to-tail configurations to also determine appropriate lead-in and lead-out distances between bays. This may significantly increase the required length of a rest area, although the desired rest outcomes will be improved.

Trees and shrubbery can be an effective way of providing noise-dampening within a rest area, and the retention of screening vegetation is highly recommended throughout the site and between the roadway and the rest area proper.

Network resiliency

Rest areas in Queensland can also play an important role in ensuring resiliency of the road network in the event of extreme weather conditions. Additional considerations that should be taken into account in the design of a rest area include:

- Rest areas should be accessible during all weather conditions affecting the road which they service. Generally, this means they should be sealed wherever possible and located where they will remain available during localised flooding.
- The rest area design should consider allowing the design vehicle to perform a 'U-turn' movement, either within the rest area, or in a controlled movement utilising the roadway, in order to return in the former direction of travel.
- Where appropriate, rest areas should be designed and built to support potential emergency management operations that may occur in the local area. These may include responses to flooding, fires, or other significant events which cause the closure of roads. The design may need to accommodate:
 - the need to safely hold an expected number of vehicles that may need to stop and wait in the area
 - to provide sites where emergency services can establish local coordination or support centres if required, including use of the site as a supply distribution point for communities cut off during emergency events, and
 - additional water storage for bushfire response and access for water trucks.
- It is important to cater for all expected vehicle types and, where possible, separate them within the rest area. For motorists, it is important to provide an adequate number of larger bays for caravans and RVs. When providing heavy vehicle spaces in rest areas, it is important to accommodate the largest size of heavy vehicle using the route, such as B-doubles.
- Rest areas also provide places for heavy vehicle drivers to check their loads and vehicles and fill in work diaries. Rest areas are not break-down or de-coupling pads and should be used primarily for the purpose of enhancing fatigue management and improving road safety outcomes. If there is a need for de-coupling or other freight-related activities to occur, they should be clearly separated, preferably at a different location where the sleep of resting drivers will not be disturbed by excessive activity, and
- For heavy vehicle drivers, rest areas are considered a working area, and workplace health and safety considerations would apply. Driver safety, including safe access to amenities, is an important consideration.

The length of vehicles may also require consideration. Heavy vehicles can be up to 53.5 m in length or sometimes longer so may require either a lot of room or a straight drive through situation which is not impeded by other vehicles such as caravans blocking their ability to move.

In many areas of rural Queensland, a simple and consistent design can be applied to roads with medium to low Average Annual Daily Traffic (AADT) levels. It should be remembered that these sites are generally also key freight routes for high productivity vehicles such as B-triples or BAB Quad vehicles where the preferred design will be required to reduce the need to turn or manoeuvre vehicles. As such, a left-in / left-out design is preferable so that the vehicle can move through the site without the necessity to turn the vehicle.

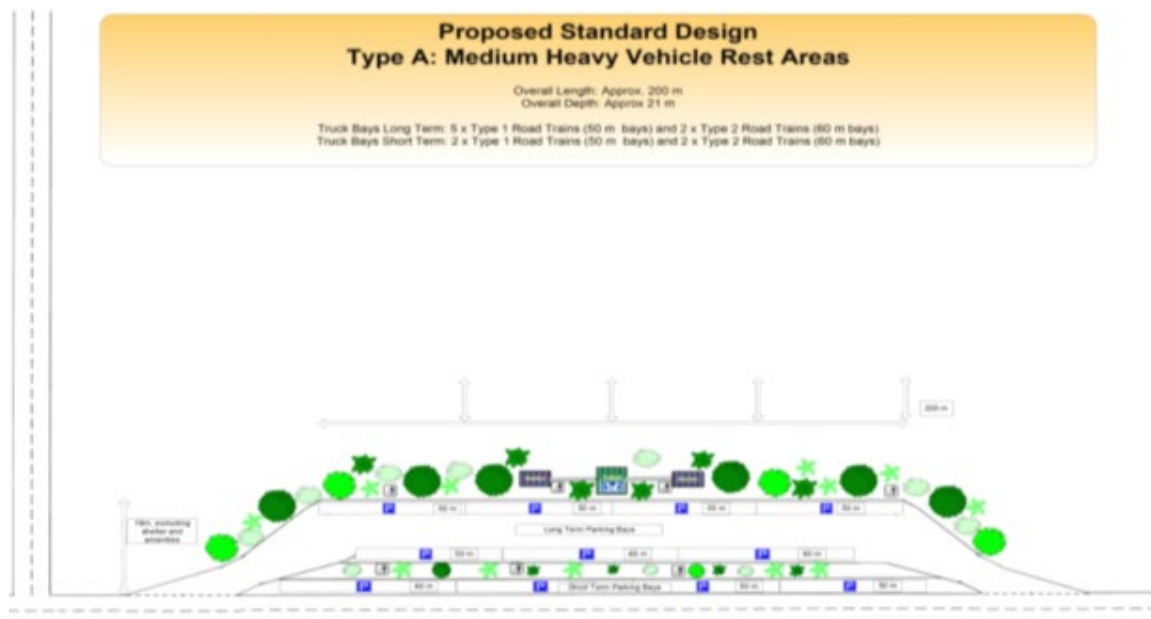
Given adequate size, sites of this design can service both heavy vehicles and motorists, thus minimising ongoing maintenance costs of facilities. They are also able to be expanded to meet future demands of the road, particularly if there is further depth available in the corridor on which additional separated sections can be added.

Figure 6B-11 is an example of a template design that may be appropriate for a small or medium heavy vehicle rest area.

Figure 6B-10 – Rural rest area 14 km north of Surat on Carnarvon Highway provides shade, shelter, table and water

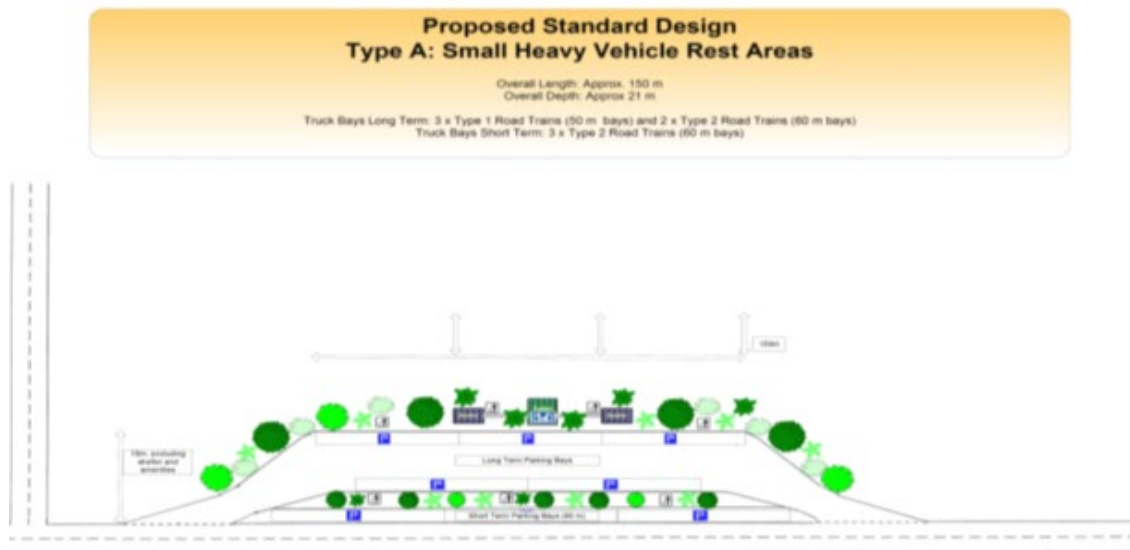


Figure 6B-11 – Environment providing for a medium number of heavy vehicles with basic facilities



For more remote areas, a simpler design utilising a single bay may be appropriate where usage levels are quite low, yet combination types are potentially large as per example template design in Figure 6B-12.

Figure 6B-12 – Environment providing for a small number of heavy vehicles with basic facilities



On higher use roads, there is a greater need to separate vehicle types within a rest area to ensure that heavy vehicle drivers are provided with appropriate opportunities to rest whilst not inconveniencing general motorists or having their own rest interrupted.

The following dual rest area is a popular spot on the Bruce Highway north of Gin Gin. It provides shade, shelter, tables, water, and toilets. It is accessible for all motorists, and also can be used by transport inspectors during operations as it contains an off-road weigh pad.

The site is located only 1 km from a 24 hour roadhouse operation, thus also providing the opportunity for access to food and fuel. The design allows for ease of manoeuvrability for larger vehicles (nose-to-tail parking), separates motorists from heavy vehicles, provides good shade, and a high level of facilities suitable for the high number of road users utilising the site.

Facilities such as toilets are shared, with the main loop nearest the road being the truck parking area. Cars and caravans are directed to the back of the site with a more scenic outlook, and to avoid pedestrian contact with manoeuvring heavy vehicles.

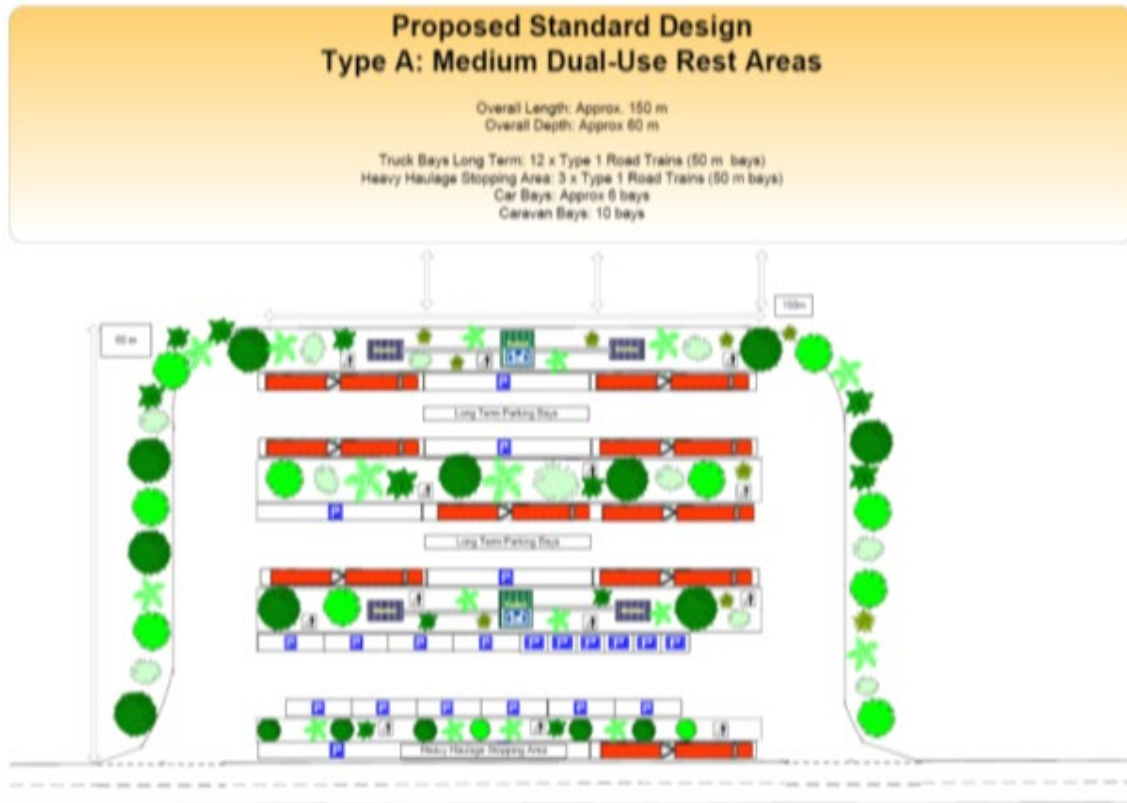
Figure 6B-13 - Rest area in a medium volume and mixed traffic location



The following site can be used as a basic design for a medium-sized dual rest area that provides high level facilities to both motorists and heavy vehicle drivers on high level routes across the network.

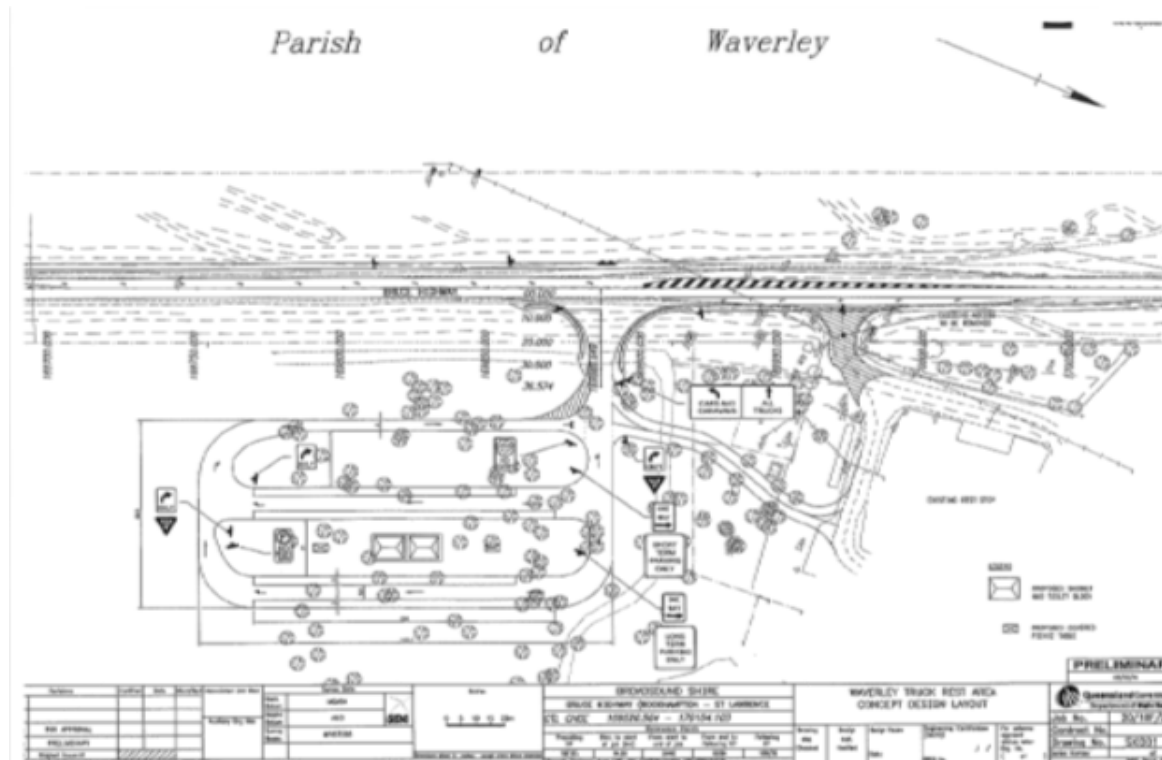
This site provides for short-term truck parking adjacent to the roadway, short-term car parking with direct access to facilities that do not interfere with truck movements, and long-term truck parking at the rear so drivers can rest more effectively.

Figure 6B-14 - Environment providing for both heavy vehicles and tourist traffic



Expansion of existing motorist sites to include areas for heavy vehicles can also be an effective way of minimising ongoing maintenance costs. The following design (Figure 6B-15) has been developed to create a new heavy vehicle rest area adjacent to an existing motorist rest area. This design provides a high level of facilities and large vehicle capacity.

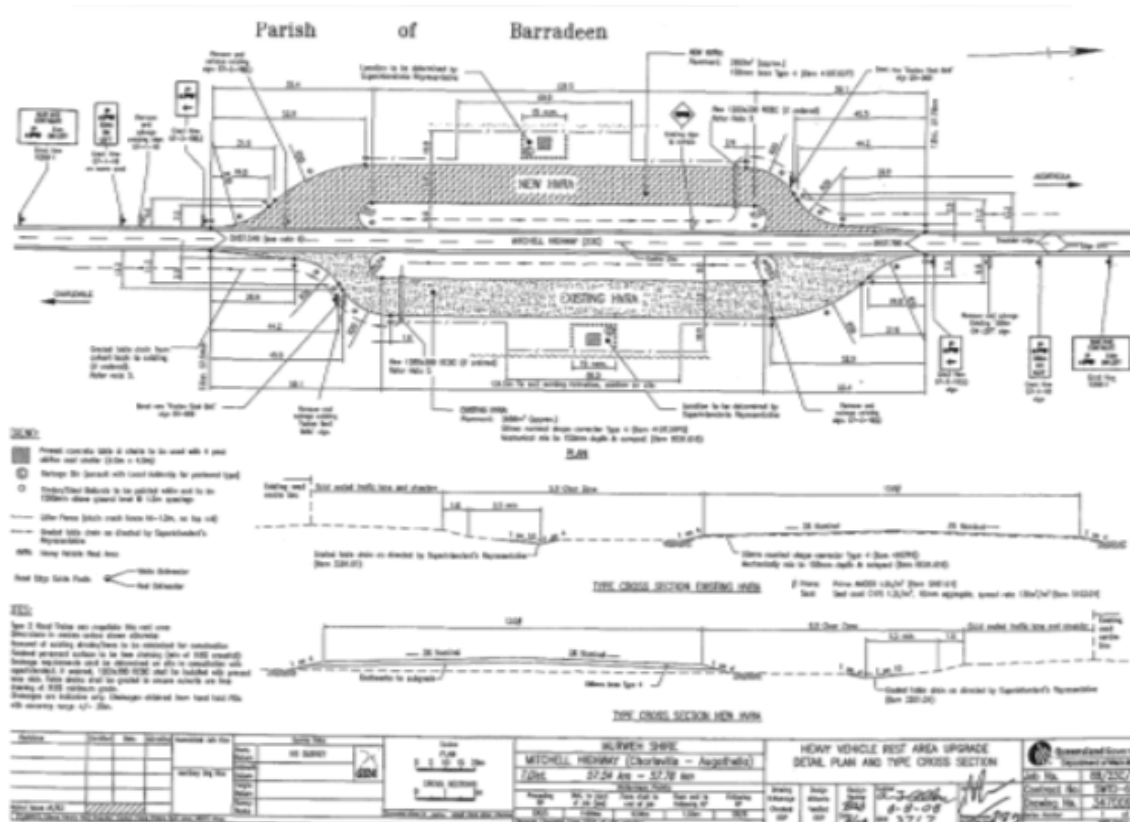
Figure 6B-15 – Dual-use rest area design



Similar sites could potentially be constructed utilising a staged approach over a period of years. Other options, such as duplication of the rest area on the opposite side of the corridor, could also be effective in reducing costs through providing access to shared facilities and minimising safety treatments on the road itself that may be required with a non-duplicated design.

The following dedicated heavy vehicle rest area (Figure 6B-16) is designed for use in a rural or remote area where lower usage is experienced. It utilises the duplication of sites on both sides of the corridor to minimise turning manoeuvres required of vehicles, which, on this section of road, are likely to include large multi-trailer combinations. This design is an economical and effective approach for more remote areas.

Figure 6B-16 – Simple duplicated rest area designs can remove the need for expensive turning lanes



3.4.5 Signage

Difference

In Queensland, the signage for rest areas should be provided in accordance with the Transport and Main Roads *Manual of Uniform Traffic Control Devices* (Queensland MUTCD), Part 6 *Service and Tourist Signs*. In addition, Transport and Main Roads *Queensland Guide to Road Safety* (QGRS), Part 2 *Safe Roads* provides details on the required signs and examples of the use of signage for rest areas.

Addition

First Nations Acknowledgements

An acknowledgement within a rest area may provide the opportunity for motorists to engage with information about the First Nations of that land, locally significant events or people, whilst resting and managing their fatigue. Consideration should be given to the possibilities for acknowledgements of First Nations people should an opportunity be identified during consultations with the community. These acknowledgements could be in the form of plaques and other monuments. When determining plaque and or monument locations, road user safety should be considered.

3.5 Roadside Vending Sites

There is no equivalent Section 3.5 in Austroads *Guide to Road Design – Part 6B*.

New

Roadside vending involves the selling of articles either directly or from a stall or standing vehicle on a road. The selling of goods and services in this way is potentially dangerous, as vehicles may suddenly swerve or stop, creating unsafe situations with moving traffic.

Stalls on private land adjacent to the road will potentially attract the same approval conditions as roadside vending sites within the road reserve, because of the possible impact on traffic safety.

Transport and Main Roads *Roadside Vending on State-controlled Roads Guideline*, *Roadside vending on State-controlled Roads Fact Sheet* and *Roadside Vending on State-controlled Roads Technical Assessment Guide* detail the assessment process.

3.6 Heavy Vehicle Interception Sites

There is no equivalent Section 3.6 in Austroads *Guide to Road Design – Part 6B*.

New

Heavy vehicle interception sites are designed to provide a safe area outside the road carriageway for weighing and inspecting heavy vehicles. They may also be used for a range of other purposes including:

- inspecting other vehicles
- undertaking other enforcement activities by Police or other authorised officials
- motorist use for short stops to inspect their own vehicles (provided the site is not being used for official purposes), and
- emergency vehicles use as required.

The Transport and Main Roads *Heavy Vehicle Interception Site (HVIS) Design Manual* provides technical guidance for design requirements of HVISs which are designed to provide a safe area outside the road carriageway for multiple purposes.

3.7 Queensland Police Service (QPS) Enforcement Bays

There is no equivalent Section 3.7 in Austroads *Guide to Road Design – Part 6B*.

New

Police enforcement activities may occur at a range of locations along a route including at rest areas and heavy vehicle interception sites. In addition, police activities may be focused on other locations along a route for alcohol and drug testing and other traffic offences.

Discussions with the Queensland Police Service (QPS) have identified the following requirements for the safe use of a site for police operations:

- At minimum 1 m police operating area around all sides of the target vehicle (on which enforcement is undertaken) with all vehicle doors in the open position. On the side furthest from the road, this operating space is not to include batter slopes or areas behind barriers.
- A 3 m clear space between the police operating area and the edge of the nearest lane of traffic.

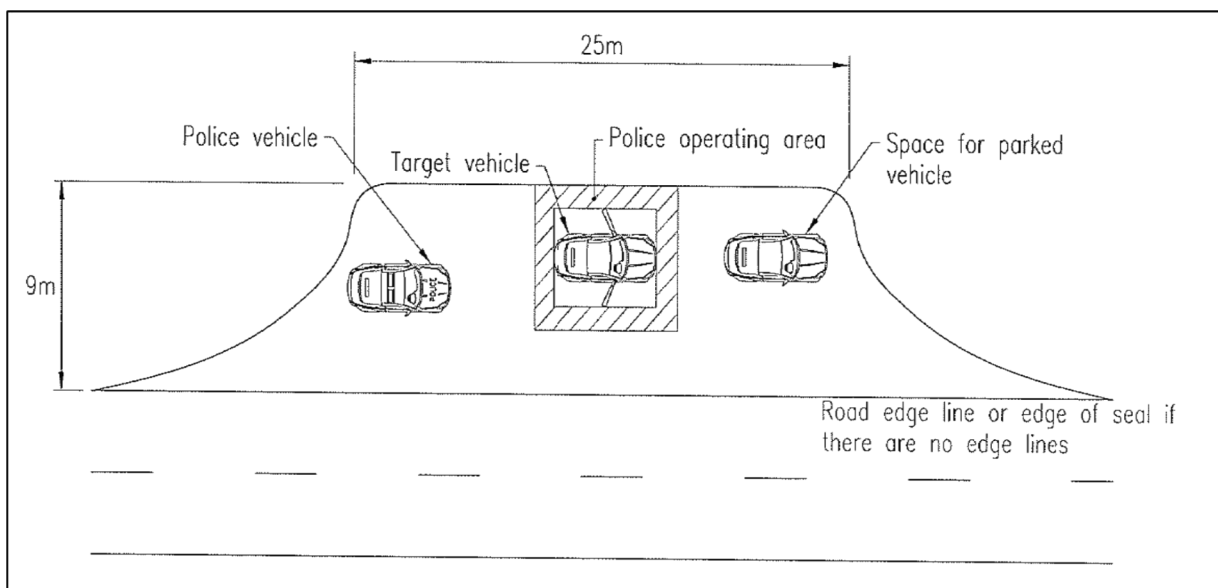
- The police vehicle will be located one full car length behind the target vehicle and offset half a car width closer to the road. This position allows the police vehicle to quickly re-enter the road if required, and
- Allowance should be made for an additional target or parked vehicle at the site.

These requirements therefore require that the police enforcement interception site should measure approximately 25 m long by 9 m wide as shown in Figure 6B-17.

The access and egress from these sites should be designed in accordance with the requirements for rest areas.

The need for incorporating the provision of these sites in road upgrade projects should be determined in consultation with the relevant departmental office and QPS.

Figure 6B-17 – QPS enforcement bay requirements



3.8 De-coupling Pads

There is no equivalent Section 3.8 in Austroads *Guide to Road Design – Part 6B*.

New

De-coupling pads are designed to allow multi-combination vehicles to be broken up / combined to meet the approved routes as defined by the department and the National Heavy Vehicle Regulator.

De-coupling pads are generally located close to where changes in heavy vehicle route occur (for example, Type 2 Road train route to Type 1 Road train route, or Type 1 Road Train route to a B-double route).

3.9 Stockpile Management

There is no equivalent Section 3.9 in Austroads *Guide to Road Design – Part 6B*.

New

Material stockpile pads are located across the Queensland SCRN. Material stockpile pads may:

- be permanent or semi-permanent
- contain a variety of road construction material stockpiled for future use, or spoil stockpiled from previous construction project
- be natural ground surface or be sealed to make a hardstand area
- may be actively utilised and managed or may be sporadically utilised for construction projects when required, and
- be a variety of sizes ranging from small (approximately 100 m²) to large (approximately 1500 m²).

Environmental impacts associated with stockpile pads include:

- sediment transport from stockpiled materials and erosion from natural ground surface
- contamination leaching and transport from stored materials (for example, hydrocarbon pollution from recovered pavement materials or excess pre-coated aggregate materials)
- biosecurity risks associated with vehicles (both departmental and public) utilising the site (for example, weed seed dispersal)
- nuisance from dust, noise and vibration, and
- illegal dumping risks associated with members of the public pulling up and dumping waste.

Considerations for siting new stockpile pads should include:

- set back distance from waterways
- avoidance of high environmental or cultural heritage values
- level ground to enable stormwater management
- safe ingress and egress for traffic, and
- intended purpose or use of the stockpile pad (once off, ongoing use).

Stockpile pad design should consider:

- Diversion of upslope water or capture any runoff from the site (such as through an earth bund).
- Site crossfall to direct drainage to either a suitably designed sediment control (for example, single sediment basin or split crossfall and drain to 2 sediment basins) or other control device. Drainage and sediment control structures should be designed in accordance with MRTS52 *Erosion and Sediment Control* Table 10.2 *Design requirements*.
- Potential pollutants such as hydrocarbons from pre-coated screenings if applicable.
- Dust generated from the site.
- Intent of the stockpile pad (for example, type of material, duration of stockpiling, whether excess material will be spoiled on the pad or whether the pad will be kept empty for use by construction and maintenance projects).

- Aesthetics and screening the stockpile pad, and
- Restriction of access to avoid unwanted use, such as free camping, and illegal dumping at the stockpile pad.

3.10 Extraction Sites

There is no equivalent Section 3.10 in Austroads *Guide to Road Design – Part 6B*.

New

In rural areas sourcing of gravel for road construction and maintenance may involve non-commercial quarry sources because of extensive haulage distances from commercial quarries. This operation involves the creation of extraction sites (otherwise known as gravel pits, borrow pits or quarries) where materials have been found to have suitable characteristics for engineering purposes.

Extraction sites typically range in size from 1.5 ha to 5 ha in size depending on the:

- volume of material required for construction
- depth of suitable material insitu (the shallower the gravel, greater the surface area of disturbance required to source the material), and
- environmental and heritage restrictions to the extraction operation.

Access to quarry material and the operation of non-commercial pits or quarries is governed by a host of legislation dependent on the location, volume extracted, and ownership of the material in addition to the end use and contractual framework under which the material is supplied. Depending on the adjacent land use and the locations of suitable gravel, it may also be necessary to site extraction sites within the road corridor. All extraction sites have associated risks including but not limited to:

Safety:

- retention of water in the pit attracting livestock and native fauna to the edge of the road and increasing the risk of vehicle strikes
- dust from gravel extraction, and
- vehicles leaving the road.

Environmental:

Environmental impacts associated with extraction sites must be included in the overall environmental assessment of infrastructure projects. Impacts can include:

- environmental approval conditions and compliance
- erosion and sedimentation risks associated with large, cleared areas
- difficulty in revegetating areas due to retention of water therefore becoming a degraded area, and
- weed introduction due to the availability of water and ground surface disturbance next to road.

Planning of new extraction sites within or outside of the road corridor should consider:

- whether the quarry material is owned by the landholder or the state
- whether the extraction site will be a once off use for a project or an ongoing extraction site
- whether the site will provide materials exclusively to Transport and Main Roads

- who will be operating and managing the site
- what contractual arrangements will be in place for the supply of the material to Transport and Main Roads
- what subsequent approval requirements and conditions apply (including native title and cultural heritage)
- the department's responsibilities for the extraction site
- what documentation and record keeping is required for the site
- rehabilitation needs and costs, and
- monitoring requirements.

Establishment of extraction sites within the road corridor is generally not preferred due to the above considerations, however, there are situations where it may be necessary and appropriate. Planning and design of extraction sites within the road corridor should consider the following design recommendations:

- the extraction site should be outside the hazard-free zone
- site on relatively flat terrain or with a perpendicular crossfall to avoid long disturbances down slopes
- batter slopes should be drivable (1 in 4)
- strip topsoil and re-spread post extraction to revegetation the site
- where possible, outlet the extraction site to drain water so that water is not retained close to the road for prolonged periods attracting wildlife and increasing risk of vehicle strike, and
- restriction of public vehicle access to the pit (i.e., earth berm) site once construction completed to avoid illegal dumping and free-camping risks.

All extraction sites should be left safe, stable, and non-polluting.

4 Roadside Infrastructure

4.1 Road Furniture

4.1.2 Signs, markings and delineation

Addition

In addition, details with regards to signs marking and delineation are contained within the Transport and Main Roads Queensland MUTCD.

Guide posts

Also refer to the Transport and Main Roads' Standard Drawings:

- Road edge guide posts, and
- Flood depth indicators.

4.1.3 Poles

Addition

Also refer to Transport and Main Roads:

- TRUM Manual, Volume 3 - *Signing and Pavement Marking, Part 5 Design Guide for Roadside Signs*, and
- *Standard Drawings*.

Selection and positioning

In urban areas on kerbed roads, poles should be placed as far behind the kerb as possible. Where possible, poles should be placed on the property side of any footpath rather than the past practice of just behind the kerb.

Non-yielding poles without barrier protection should not be erected at locations where they may be more vulnerable such as the following:

- adjacent to horizontal curves with a speed value less than 80% of the 85th percentile speed of the element
- on most traffic islands (particularly small ones) at intersections
- on narrow medians
- adjacent to road pavements that may become slippery under adverse conditions, and
- in gore areas adjacent to off ramps (poles in gore areas should be avoided).

If a road safety barrier is required to shield a pole, adequate clearance, commensurate with the barrier type, between the sign supports and the barrier must be provided.

4.1.5 Supports for road signs

Addition

Supports for road signs must be designed in accordance with the Transport and Main Roads TRUM Manual Volume 3 – *Signing and Pavement Marking, Part 5 Design Guide for Roadside Signs* and Transport and Main Roads *Standard Drawings*. The post sizes for signs requiring multiple supports will often be of a size that should be made breakaway.

4.1.6 Fences

Addition

Fencing requirements should be determined by a risk assessment taking into consideration the impacts on all road corridor users.

Particular attention should be given to the height and placement of a fence, and to the material used in its construction so as to minimise the potential sight obstruction between all road users such as drivers, cyclists and pedestrians.

Inappropriate use of a fence near parking bays may prevent occupants from leaving a vehicle parked close to it.

Specific uses of fences and design considerations

The following is to be added to Table 4.1 of Austroads *Guide to Road Design – Part 6B*.

Use	Comment
Vermin and dog fences	Vermin and dog fences are required to prevent the spread of vermin and wild dogs and are to be erected as required by the Department of Agriculture and Fisheries.

The height of fence will depend on its function and the potential hazards involved. A 1.2 m fence is usually required along the right of way unless other arrangements are made with property owners. Where security fencing is required, or it is important to discourage pedestrian access, a 1.8 m high fence is required.

Fences are generally the responsibility of the property owner unless resumption has occurred in which case replacement of the fencing is undertaken as accommodation works. Security fencing is the responsibility of Transport and Main Roads.

Fencing with horizontal rails must not be used within the hazard-free zone or in any location where there is the possibility of impalement.

If fencing is located behind a barrier, adequate clearance between the fence and the barrier should be provided dependant on the barrier type and the expected deflection of the barrier in the event of a crash.

With regard to the design of fences for cycling infrastructure, refer to the Transport and Main Roads *Fencing and edging treatments for cycling infrastructure Guideline*.

Stock grids

In Queensland, 'stock grids' are known as 'motor grids'.

If the AADT exceed 700, grids are not suitable and the road should be fenced to ensure adequate safety for the traffic.

Full design details are included in Transport and Main Roads *Standard Drawings*.

4.2 Road LightingDifference

The design of lighting in Queensland is to be undertaken in accordance with RPDM Volume 6.

4.3 Emergency / Help Telephones**4.3.1 General**Addition

The design and planning of emergency / help phones should be undertaken in accordance with this section and the following Transport and Main Roads documents:

- Engineering Policy 149 *Managed Motorways*

- *Queensland Guide to Traffic Management (QGTM) Part 9 Transport Control Systems – Strategies and Operations*, and
- Any Transport and Main Roads advice notes in operation¹.

4.4 Off-street Parking

4.4.1 Introduction

Addition

In addition to on-street parking, which is addressed in RPDM Volume 3, Part 3, and off-street parking, which is addressed in this section, parking may also be provided in the verge area of a road. This latter form of parking provision is not addressed in the existing documentation in the Austroads *Guide to Road Design* Part 6B. A new Section 4.4.9 has therefore been included in this document to address this topic.

Verge and indented parking is typically provided between the kerb line and property boundary and can be a cost-effective retrofit measure to relocate parking from the road pavement to the verge in order to make space for other use of the road space (such as on-road bicycle lanes).

It is recommended the design for disability parking spaces is in accordance with AS/NZS 2890.6, which sets the minimum requirements for accessible car parking spaces in Australia. This standard is also be read in conjunction with this section.

4.4.5 Car parking area layout design

Addition

Parking areas

The design of parking areas must also consider the practice of 'Crime Prevention through Environmental Design' (CPTED) as described in the Transport and Main Roads *Road Landscape Manual*. Specific measures for parking areas that may be considered include:

- Avoiding obstructions to sight lines and avoiding potential entrapment spots by:
 - eliminating dense bushes, solid fences or advertisements that obscure the view
 - eliminating unnecessary buildings or sheds (i.e., hiding places)
 - maximising sight lines from the entrances / exits to the various parts of the area
 - using low fences and low growing shrubs as the boundaries of the area, and
 - using trees with a large clear trunk at maturity to provide clear sightlines, and minimising conflict with lighting and CCTV requirements.
- Enhancing natural surveillance by:
 - locating the area to take advantage of buildings with windows overlooking the area
 - taking advantage of adjacent or nearby business premises or houses so that the occupants can see the area
 - landscaping with low groundcovers and tall trees with clear canopies

¹ To determine what, if any, Transport and Main Roads advice notes are in operation, please contact Strategic Network Management via StrategicNetworkManagement@tmr.qld.gov.au.

- maintaining landscaping to prevent it obscuring the view of the area, and
- using 'see-through' fences rather than solid walls as boundaries.
- Providing lighting such as:
 - lighting is uniform to avoid deep shadows.
- Providing shade to reduce heat island effect of car parks by:
 - providing regular spaced trees to the perimeter of the car park
 - providing regular trees to internal areas of large car parks
 - prioritising tall spreading trees to maximise shade while minimising potential conflict with lighting and CCTV requirements
 - ensuring the coordination of services and other engineering requirements, and
 - incorporating structural soil cells and tree grates as necessary in contained concrete and pavement areas to promote increased root zone volume to ensure establishment and long-term health of the tree.
- Parking spaces:
 - for every 50 parking spaces, one disability parking space is to be provided.

4.4.9 Verge and indented parking design

There is no equivalent Section 4.4.9 in Austroads *Guide to Road Design – Part 6B*.

New

The design and planning of verge and indented parking should be undertaken in accordance with this section and the Transport and Main Roads TRUM Manual, Volume 1 – *Guide to Traffic Management, Part 11 Parking Management Techniques*.

Verge and indented parking can be a cost-effective measure for providing parking in areas where on-street parking cannot be retained.

Verge parking involves provision of a hard stand treatment on the verge such as paving or concrete to allow vehicle to park safely in the verge without disrupting pedestrian movement and other functions of the verge. An example cross-section and layout of verge parking is shown in Figure 6B-18.

Indented parking is similar but involves providing car parking in the verge at the same level as the road pavement. This therefore requires changes to the kerb line to achieve and is more suitable to locations with heavier parking demand and medium to high volumes of cyclists due to its higher costs and impacts on existing infrastructure. An example cross-section of indented parking is shown in Figure 6B-19.

The key design considerations are:

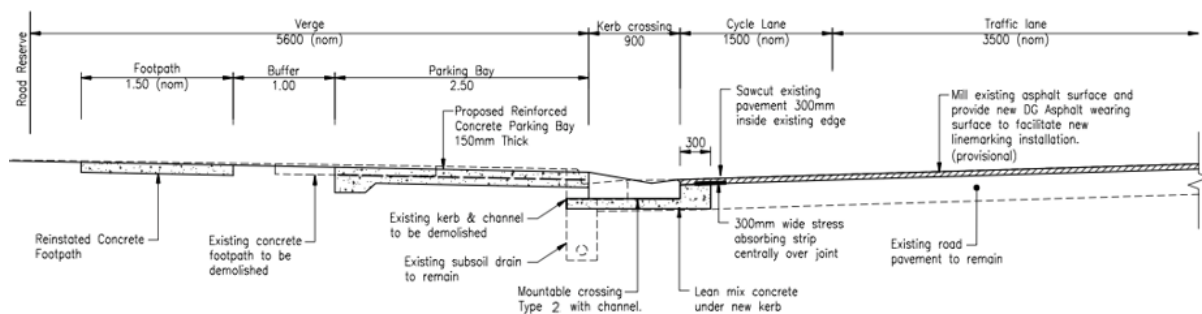
- maintaining appropriate residual width on the verge for pedestrians
- impact on sightlines for vehicles at intersections and property access
- clearance between the rear of the parking bay and pedestrian pathway considering vehicle manoeuvring and overhangs, door opening and the potential for non-compliant parking across the pedestrian facilities

- clearance on the road side of parked vehicles still needs to provide a minimum of 1 m clearance for cyclists to the 'car door zone'
- indented parking also requires consideration of stormwater drainage surface flow within the bay. Inverted crossfall to the indented bays may be beneficial to minimise impacts to drainage infrastructure
- landscaping, and
- potential conflicts with public utility plant, street furniture, roadside safety / noise barriers, property access locations, and landscaping requirements within the verge.

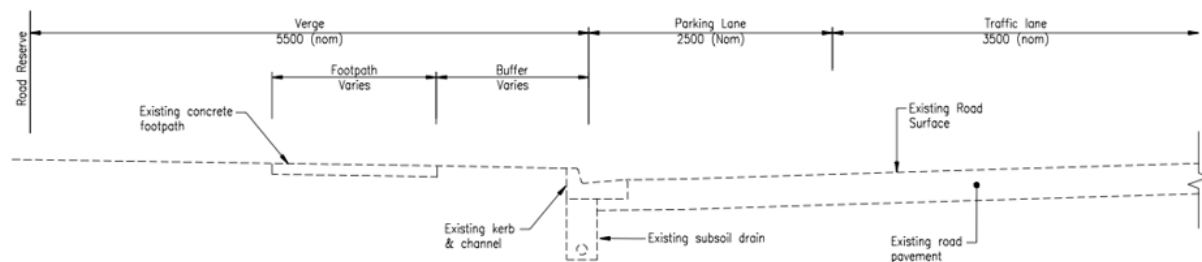
The recommended design elements for verge and indented parking are as follows:

- Dimensions and layout of parking spaces shall be in accordance with AS 2890.5.
- 5.4 m minimum verge width to maintain pedestrian access. This may be narrowed to 4.5 m in local residential streets.
- Pavement type to be sufficient to maintain structural integrity for design vehicle.
- Kerb for verge parking is to be semi-mountable or mountable.
- Channel for indented parking is recommended to be Type 22.
- Kerb for indented parking is recommended to be barrier kerb Type 5, and
- Signage to be installed as per the requirements of the Transport and Main Roads Queensland MUTCD, Part 11 *Parking Controls*.

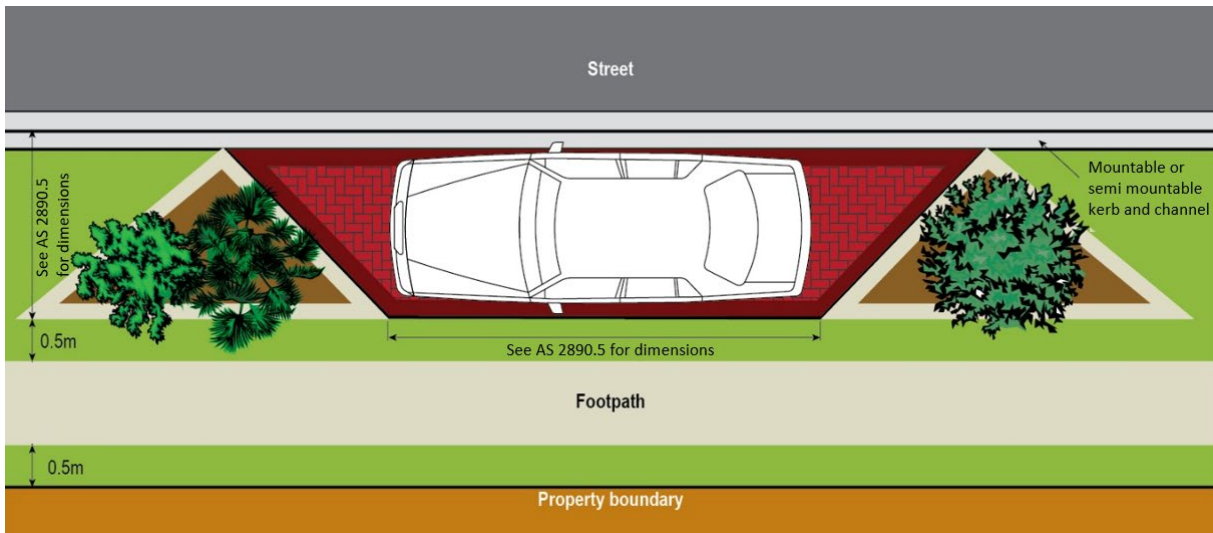
Figure 6B-18 – Example cross-section and layout for verge car parking



Verge Parking Bay Treatment
Concept Design Details

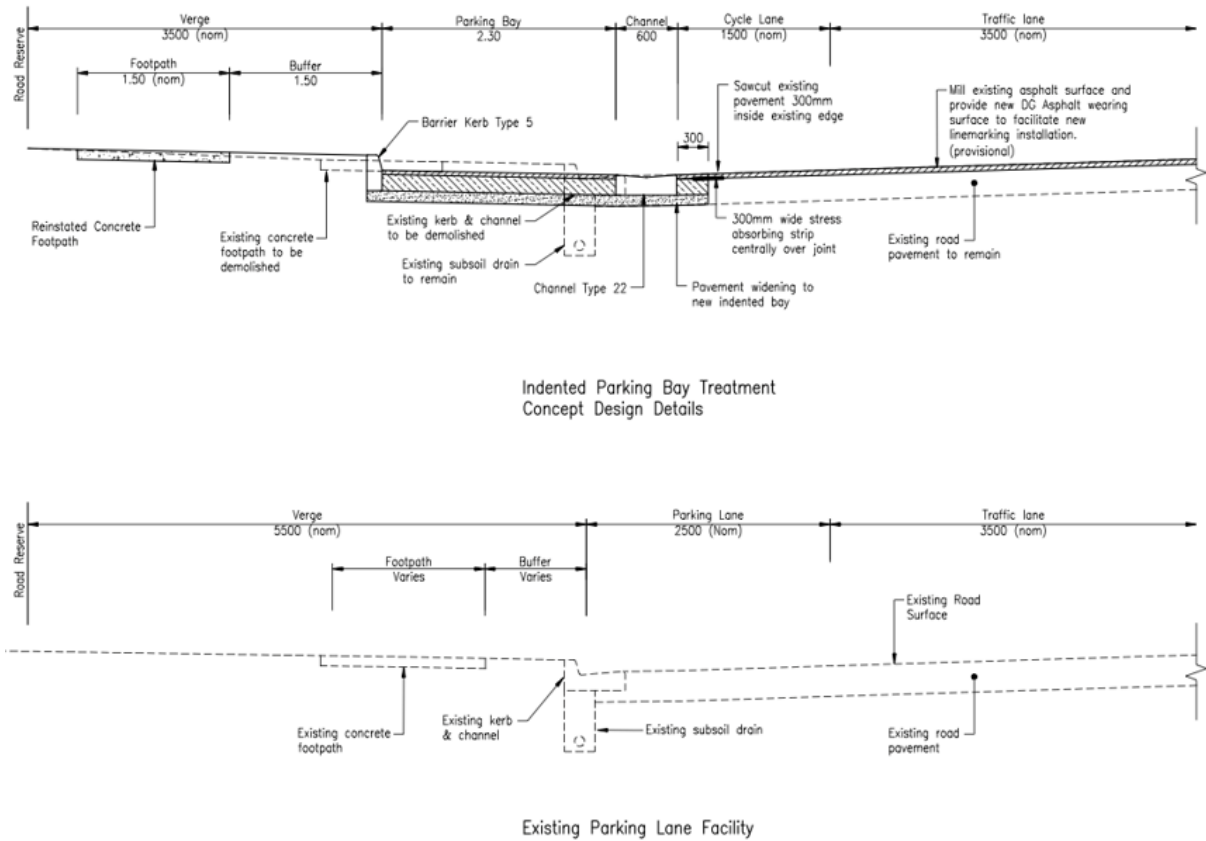


Existing Parking Lane Facility



Source: Transport and Main Roads

Figure 6B-19 – Example cross-section for indented car parking



4.5 Utilities

4.5.1 General

The *Definition* section in *Austroads Guide to Road Design – Part 6B* is to be replaced with the following text.

Difference

Definition

Utility services are usually located beside the road carriageway and cross underneath or above the road near road intersections. In rural roadsides, it is often possible to have utilities far from the carriageway at the cadastral boundary as the road corridors are wide. In urban areas the roadsides are more crowded and often utility services are in tight alignments under footpaths on both sides of the road. Public utilities provide services to the community including:

- water and waste water (sewerage) assets
- electricity entity assets (distribution, transmission and generation)
- distribution / reticulation gas, and
- low-impact telecommunications assets (for example, excludes mobile towers and overhead lines).

Other utilities, for private or commercial use, include:

- irrigation
- bulk water
- fuel lines for agricultural use
- stormwater infrastructure
- transmission gas pipelines
- mining assets, and
- telecommunications assets that are excluded by telecommunications legislation (for example, mobile towers).

The provision of public utility services is covered by legislation and confers obligations on both the public utility and the road authority. For private / commercial utilities, the *Transport Infrastructure Act 1994* specifies their obligations. Both utilities and road agencies must comply with such requirements in the discharge of their powers and obligations.

Public utilities usually have legislative but conditional rights to access road corridors. Some commercial utilities, specifically mining and transmission gas pipelines may also have land access rights. All other private and commercial use of the road corridors is at the road authority's discretion. Any joint use of roadside land requires consultation and coordination between utilities and road agencies in order to effectively manage land use to ensure its primary purpose, for road transport, is not compromised by secondary uses.

Consultation and Coordination

This section in Austroads *Guide to Road Design – Part 6B* is to be replaced with the following text.

Difference

Consultation and coordination are essential between utility providers and road agencies in all aspects of their businesses including strategic planning, project planning, design, construction and maintenance. While formal consultation is essential it is particularly important that informed and collegial relationships are also maintained between organisations at officer level.

The requirement to seek permission from the road authority (or, in the case of telecommunications, notify and give opportunity to object to works) is specified in legislation, regulations and codes of practice. These detail how the parties are to relate and provide a structure for the relationship and a process for the resolution of issues that may arise between the parties.

There are a number of Austroads and individual road authority standards and guidelines specifically written for supporting utility service management. The location of utility services should be considered in early in the planning and design processes, as they can have a significant impact on design decisions and construction cost, and there are mandatory notification requirements and timeframes under public utility legislation. Road improvement or upgrade projects will often involve service relocations which cannot be designed out, that may provide physical or economic constraints to the design. The provision of services adjacent to greenfield road developments should use typical alignment approaches and consider the future role of the transport corridor to minimise or avoid future service relocations associated with upgrading the road or utility.

Consolidated asset information services to assist in the identification and location of underground utilities are available. These services are an efficient initial interface between the designer and service authorities to enable the early consideration of services (both above ground and below ground) to occur (for example, 'Dial before you dig' may be used as a starting point for underground services).

It is incumbent upon the designer to check with the service authority and the electricity, gas, ²telecommunications and water / sewage codes before deciding on the location and design of any utility plant in the road reserve.

4.5.2 Industry codes of practice

This Section 4.5.2 in Austroads *Guide to Road Design – Part 6B* is to be replaced with the following text.

Difference

General

Codes of practice may be legislated, be developed by peak bodies or by individual utilities (including road authorities). Road designers and utility officers should be familiar with the requirements of local, state and national codes; however, these codes cannot supersede legislative powers and obligations or good engineering practice relating to the unique circumstances of a site.

Designers should seek information which code is used public utility, seek out the most recent version of the code and for roads, check with the road authorities regarding which are used.

² To determine what, if any, Transport and Main Roads advice notes are in operation, please contact Strategic Network Management via StrategicNetworkManagement@tmr.qld.gov.au.

The objectives of a code of practice are to provide practical guidance to road agencies and utilities in relation to:

- the manner in which works on roads should be carried out
- processes for consultation and exchanging information about future works
- good practice or relevant industry standards in relation to a specified type of infrastructure or works
- processes to facilitate consultation and cooperation between road agencies and utilities responsible for infrastructure on roads, and
- the interchange and storage of information regarding road and non-road infrastructure located in road reserves.

Memoranda of Understanding, protocols and agreements

Codes of practice may be underpinned by formal legally binding and non-legally binding agreements, Memoranda of Understanding (MoUs), protocols and standard contracts (also known as Recoverable Works Agreements) between road agencies and utility providers. These documents contain information relating to specific responsibilities and rights of the parties, scope of the agreement, process for the conduct of works and contractual requirements. Designers should check which utilities have current arrangements with the road authority to ensure the correct approach is used in the design.

4.5.3 Allocation of space

Difference

Replace text in Section 4.5.3 of Austroads *Guide to Road Design – Part 6B*, General with the following. The differences in text have been underlined.

The allocation of space within road corridors (road carriageway and roadsides combined) for utilities is different in each jurisdiction. However, where possible, utilities should be placed in a consistent location within road reservations in the same jurisdiction. To facilitate this, space is allocated within road reservations for the accommodation of various utilities. The authority to approve undertaking the works as a consequence of a road project is legislated differently from utility-initiated works and have different obligations. The designer should be aware of the approach the local or state road authority takes to approvals for final utility design alignments for both circumstances.

It is preferable to locate all utilities in areas that are removed from road traffic, namely within nature strips or under footpaths in urban areas, and within road verges in rural situations. It is generally undesirable to locate utilities longitudinally under road pavements, tram tracks or railway tracks, although this may be unavoidable in some circumstances. Ongoing maintenance requirements of the utility service should be considered in any design decision.

The following works and infrastructure management principles should be considered when deciding the position of new utility infrastructure or when considering modifications to existing utility infrastructure within road reserves:

- Minimising of road safety hazards, with a preference for elimination of hazards where feasible (for example, locating Public Utility Plant (PUP) off-road / off-path and outside high-risk zones, or protecting it with barriers). Where elimination is not possible, minimisation of road safety risks associated with PUP should be achieved, particularly where pits are unavoidable in the travelled way of roads or paths, such as:
 - Access lids provide a durable friction surface consistent with the surrounding travelled way surfaces
 - Control of pits in travelled way surfaces to prevent differential uplift or subsidence, and
 - Control (locking) of pit lids to prevent uplift, displacement, or fall-through, especially in areas prone to flooding.
- Avoidance or minimisation of:
 - damage or disruption to infrastructure on roads
 - disruption to plans for the development of road infrastructure and non-road infrastructure
 - disruption to traffic
 - disruption to the effective and efficient delivery of utility services, and
 - the efficient use of resources of road agencies and infrastructure managers and the minimisation of cost to the community of infrastructure and services.

In addition, road designers should:

- Consider placement of utility infrastructure in the vicinity of, or on, bridges or other road-related infrastructure (including road bridges or other structures owned by other infrastructure managers) in conjunction with all other available routing options, and
- In accordance with planning and environment legislation and government policy, and where reasonably practicable, minimise damage to:
 - street trees, including their root systems and remnant vegetation, and
 - roadside areas identified as being of high conservation value.

Codes of practice often specify a generic location for utilities, both laterally from the property boundary and the depth below the surface, based on common road reservation profiles. Figure 4.14 shows a typical allocation of space for utilities in an urban footpath / nature strip area. Variations will occur depending on the nature of the services to be accommodated and the overall space available within the road corridor.

Large services can be accommodated following negotiation with the road agency and other utility providers prior to seeking approval. In rare cases a utility service may be located beneath the carriageway where verge space is insufficient, following the necessary consultations and approval.

Figure 4.15 shows a space allocation for a paved laneway, the minimum road reserve that is likely to be encountered in urban areas. Utility services are to be placed on the side of the laneway servicing the greatest number of lots. Where a laneway lot fronts a primary street the utility services should be located in the primary street, except where constrained by topography.

Although utility providers have a commitment to comply with allocated alignments and depths, no assurance can be given that the depths of cover stated will apply for all existing facilities. Before any excavation is planned or commenced, contact should be made with the appropriate provider.

Depth of underground utility infrastructure

Underground utility infrastructure should be placed at depths that will minimise the risk of accidental damage when road agencies and others are carrying out work in road reserves.

The infrastructure should also be laid at whichever is the greater of the following:

- depths that conform to existing utility regulations and standards, and
- a sufficient depth to not damage the road substrate or other assets and allow the road agency to upgrade, maintain and repair the road pavement and road-related infrastructure such as drainage without damaging utility assets.

This generally means that wherever practicable, for crossings of the road, new utility infrastructure should desirably be located more than 300 mm below the bottom of the road pavement. Consideration should be given to the strength of the conduit and its ability to withstand the passage of construction equipment in determining the actual depth that it should be placed below the bottom of the pavement.

While depths are shown in Figure 4.14 and Figure 4.15, the depth below surface will depend on the nature of the service and the likely risk in the event that it is damaged, as indicated in Table 4.7.

Difference

Replace Table 4.7 in Austroads *Guide to Road Design – Part 6B* with the below Table 6B-2.

Table 6B-2 – Indicative depths of underground utility infrastructure

Utility	Context	Cover below surface level on roadside (mm)	Cover below road carriageway surface (mm) [#] and bored, jacked, or micro tunnelled installations	Table drains (below invert level of table drains)	From bottom of pavement subgrade and top of utility service / service conduits
Gas distribution	Street mains	750	1200	900	300
	Consumer mains	600	1200	900	300
Gas – high pressure	Street mains	1200	1200. If an enveloping pipe is impractical / infeasible for use, the minimum cover to a high-pressure gas or liquid petroleum transmission line shall be increased to 3000 mm.	900. If an enveloping pipe is impractical / infeasible for use, the minimum cover to a high-pressure gas or liquid petroleum transmission line shall be increased to 3000 mm.	300

Utility	Context	Cover below surface level on roadside (mm)	Cover below road carriageway surface (mm) [#] and bored, jacked, or micro tunnelled installations	Table drains (below invert level of table drains)	From bottom of pavement subgrade and top of utility service / service conduits
	Consumer mains	1200	1200. If an enveloping pipe is impractical / infeasible for use, the minimum cover to a high-pressure gas or liquid petroleum transmission line shall be increased to 3000 mm.	900. If an enveloping pipe is impractical / infeasible for use, the minimum cover to a high-pressure gas or liquid petroleum transmission line shall be increased to 3000 mm.	300
Electricity (power)		750	1200	900	300
Telecommunications	Street mains or consumer service – excavation installations	600	1200	900	300
	Street mains or consumer service – trenchless installations	600	1200	900	300
Water	Distribution mains	750	1200	900	300
	Reticulation mains	600	1200	900	300
	Consumer service	600	1200	900	300
Sewer	Sewer mains	900	1200	900	300
	Consumer services	900	1200	900	300
Main drainage	In verge	750	1200	900	300
	Under road pavement	900	1200	900	300
Street drainage	Street main or consumer service – in verge or under road	600	1200	900	300
Road lighting	Lighting poles and high masts, electricity supply conduits and pits	600	1200	900	300

Utility	Context	Cover below surface level on roadside (mm)	Cover below road carriageway surface (mm) [#] and bored, jacked, or micro tunnelled installations	Table drains (below invert level of table drains)	From bottom of pavement subgrade and top of utility service / service conduits
Traffic signals	Power supply	500–800	1200	900	300
	Detector cables in conduit	300	1200	900	300
	Intelligent transport system (ITS) cables in conduit	500	1200	900	300

[#] Refer Technical Note 163 *Third Party Utility Infrastructure Installation in State-Controlled Roads Technical Guidelines* Table 5.2.1 – *Minimum depth of cover for electrical and communications utility services.*

Difference

In the paragraph under Table 4.7, remove the wording 'or cost effective' from the second sentence.

Difference

Add the underlined text to Section 4.5.3, *Austroads Guide to Road Design – Part 6B*, Spacing between underground utility infrastructure.

Underground utility infrastructure should be separated by distances that conform to existing utility regulations and standards.

Desirable locations of services and coordination principles vary depending on the responsible authority involved and available land. Wherever possible, different types of underground utility infrastructure should be spaced a sufficient distance apart in order to minimise the risk of accidental damage when authorities are installing, upgrading or maintaining their infrastructure. However, common trenching on the roadside may be used to install more than one service at the same time. Water and gas mains are usually constructed in a common trench, while communication and electricity cables may also be included. Common trenching reduces the total construction costs and the time required to install these services individually. Trenching across roads should not be permitted except in exceptional circumstances, instead, under boring / tunnelling should be used.

4.6 Intelligent Transport System Infrastructure

There is no equivalent Section 4.6 in *Austroads Guide to Road Design – Part 6B*.

New

The incorporation of ITS infrastructure in the roadside environment is now commonplace. There is a wide range of ITS infrastructure elements in use which are discussed in *Transport and Main Roads Queensland Guide to Smart Motorways (QGSM)*.

Due to the often-critical nature and cost of this infrastructure, road design needs to take into consideration the following specific elements associated with ITS design:

- protection (barriers) of non-frangible and/or high value ITS infrastructure
- use of frangible ITS infrastructure where barrier protection cannot be provided and/or ITS infrastructure is of lower value, and
- provision of access for maintenance activities.

5 Roadside Environment Safety Considerations

5.1 Animal / Vehicle Collisions

There is no equivalent Section 5.1 in *Austroads Guide to Road Design – Part 6B*.

New

In addition to fauna management for conservation purposes (including avoiding animal / vehicle collisions), fauna management for public safety is also a consideration for planning and design of roadside environments. Where there is a known risk of large feral animals and uncontrolled domestic stock accessing the road corridor, a number of management options exist, depending on the species, level of risk to road users and the adjacent land use. There is information on the process for reviewing the risks and determining suitable action on the department's Environmental Management System. Contact the Manager (Environment) at environment@tmr.qld.gov.au for the latest guidance material.

Typically, the only design measure to manage the risks associated with large feral animals and uncontrolled domestic stock is fencing.

Installation of exclusion fencing must consider ongoing maintenance requirements and the increased risk to motorists if animals become trapped in the road corridor. This is also a concern where adjacent landowners install fencing on the boundary of the corridor on both sides (for example, wild dog fences). For further information on fencing, refer to Section 4.1.6 of this supplement.

5.2 Bushfire Risk Planning and Design

There is no equivalent Section 5.2 in *Austroads Guide to Road Design – Part 6B*.

New

Bushfire management should consider the impacts of fire on the road infrastructure, assets and users, and also on adjoining property. Ongoing vegetation management for fuel hazard can be expensive, so early design to manage future fuel loads is imperative.

Current science suggests that the intensity and severity of bushfires has increased in many areas of Queensland. Planning and design of road and roadside environments should consider the likelihood and consequence of bushfires both in the current climate and in the projected future climate conditions. Queensland has mapping of Bushfire Prone Areas developed by the Queensland Fire Department (QFD) and the Commonwealth Scientific and Industrial Research Organisation (CSIRO)³.

When planning and designing roads, consideration should be given to the role of the road before, during and after a bushfire. Roads provide a number of important functions:

- serve as a significant and extensive firebreak

³ <https://www.planning.qld.gov.au/planning-framework/mapping>

- access and setting for preventative bushfire fuel treatments (for example, prescribed burning, slashing)
- escape routes for communities threatened by bushfire
- movement and access for first responders during a bushfire
- supply lines for recovery crews after a bushfire, and
- can include water sources and access to water for firefighting purposes.

The importance of these functions for a particular road depends on the context across the broader transport network and landscape. Roads that provide a single point of access to a vulnerable community are particularly critical. Lack of consideration of bushfire risk in road planning and design can directly impact the resilience of the community.

Roads in bushfire prone areas can also provide an important role in bushfire management within the broader landscape. For instance, a road may provide a firebreak that can assist in controlling the spread of bushfire.

Road corridors can also present potential ignition sources for bushfires (for example, discarded cigarette butts, motor vehicle accidents, and points of access for arson). Bushfire coming from the State-Controlled Road corridor can be a significant concern for adjoining landholders, and planning and design consideration should be given to ensuring that appropriate landscape design and vegetation management do not exacerbate bushfire risk to adjoining property (for example, ensuring a lower-fuel area along road reserve boundaries where reserve width allows).

Planning and design should include considerations for road corridors that have elevated bushfire likelihood and consequence under current climate and future climate projections.

NOTE: The below considerations are NOT intended to provide a comprehensive design guide for addressing the potential impacts of bushfire on roads and the broader landscape. However, there are a list of potential bushfire risk factors that should be considered during the planning and design of roads or roadside environments.

Bushfire prone area and Regional Bushfire Risk Assessment Mapping (RBRAM):

- Consider whether the road section is in a QFD-mapped bushfire prone area category (i.e., Very High Potential Bushfire Intensity, High Potential Bushfire Intensity, Medium Potential Bushfire Intensity, and Potential Impact Buffer), and/or an area identified as high or extreme risk through the RBRAM, and
- Consider the climate projections over the whole of life of the asset in accordance with Engineering Policy 170 *Climate Change and Natural Hazards Risk Assessment*. Investigate whether the bushfire risk will change with future projections.

Risk to the road asset and level of service from bushfire:

- A Bushfire Attack Level (BAL) assessment, which measures the potential exposure of a proposed site to a bushfire event, may help in designing and constructing structures to withstand bushfire impacts by considering factors such as material selection, vegetation management, and emergency access routes.
- Consider the consequence of a bushfire impacting the road in terms of continuation of service, human life, economy and damage to asset. Asset failures prevent safe movement and access to vulnerable communities during bushfire emergency response and during recovery.
- Consider whether there are existing fire-susceptible components of the asset.
- Consider selection of construction materials or components that are resilient to bushfire.
- Consider roadside vegetation and potential for bushfire impacted timber to pose risk to road and road users, and adjoining property, such as QPWS land. Vegetation considerations need to be balanced with consideration of conservation values, amenity, erosion and sedimentation risks and biosecurity management.
- Consider smoke hazard impacts to road and potential network operation impacts and management.
- Consider whether the road provides an escape route in the event of bushfire, such as a single access road.
- Consider how important the road is for movement of emergency services prior to and during a bushfire, and in the recovery phase, and
- In the event of bushfire emergency, consider emergency planning and network continuity planning including communication to road users through signage.

The role of road design in prevention and management of a bushfire across the broader landscape:

- Identify whether the road provides a firebreak between bushfire prone areas and communities or other vital infrastructure.
- Consider the need for and feasibility of incorporating a firebreak into the road design – either perpendicular to the road, extending the road, or along the road reserve boundary. Consider potential adverse impacts to environment, heritage and amenity.
- Consider the likelihood and consequence of ignition within the road corridor. Consider management strategies for reducing likelihood or consequence of a bushfire igniting within the road corridor such as roadside vegetation management to reduce likelihood of spread from source of ignition, and
- Consider the value and community benefit of including firefighting water tanks in the design and planning of rest areas and other roadside amenities.

References

Transport and Main Roads publication references refer to the latest published document on the departmental website (www.tmr.qld.gov.au).

Addition

Austrroads. (2021). *Guide to Road Design – Part 6B: Roadside Environment*. Sydney, NSW

Department of Agriculture and Fisheries. 2018. *Accepted Development Requirements for Operational Work that is Constructing or Raising Waterway Barrier Works*. Brisbane: Queensland Government

Department of Transport and Main Roads. *Conservation Land Assets (CLA) Framework*. Brisbane: Queensland Government

Department of Transport and Main Roads. *Cultural Heritage Organisational Policy*. Brisbane: Queensland Government

Department of Transport and Main Roads. Engineering Policy 149 *Managed Motorways*. Brisbane: Queensland Government

Department of Transport and Main Roads. Engineering Policy 170 *Climate Change and Natural Hazards Risk Assessment*. Brisbane: Queensland Government

Department of Transport and Main Roads. *Environmental Offsets Policy* (internal only document). Brisbane: Queensland Government

Department of Transport and Main Roads. *Environmental Processes Manual*. Brisbane: Queensland Government

Department of Transport and Main Roads. *Fauna Sensitive Transport Infrastructure Delivery Manual*. Brisbane: Queensland Government

Department of Transport and Main Roads. *Fencing and edging treatments for cycling infrastructure Guideline*. Brisbane: Queensland Government

Department of Transport and Main Roads. *Heavy Vehicle Interception Site (HVIS) Design Manual*. Brisbane: Queensland Government

Transport and Main Roads. *Manual of Uniform Traffic Control Devices (Queensland MUTCD)* . Brisbane: Queensland Government

Department of Transport and Main Roads. *Movement and Place Policy*. Brisbane: Queensland Government

Department of Transport and Main Roads. *Movement and Place Practitioner Guidance*. Brisbane: Queensland Government

Department of Transport and Main Roads. *Queensland Guide to Road Safety (QGRS)*. Brisbane: Queensland Government

Department of Transport and Main Roads. *Queensland Guide to Smart Motorways (QGSM)*. Brisbane: Queensland Government

Department of Transport and Main Roads. *Queensland Guide to Traffic Management (QGTM)* . Brisbane: Queensland Government

Department of Transport and Main Roads. *Road Landscape Manual*. Brisbane: Queensland Government

Department of Transport and Main Roads. *Road Planning and Design Manual (RPDM)*. Brisbane: Queensland Government

Department of Transport and Main Roads. *Road Safety Policy*. Brisbane: Queensland Government

Department of Transport and Main Roads. *Roadside Vending on State-controlled Roads Fact Sheet*. Brisbane: Queensland Government

Department of Transport and Main Roads. *Roadside Vending on State-controlled Roads Guideline*. Brisbane: Queensland Government

Department of Transport and Main Roads. *Roadside Vending on State-controlled Roads Technical Assessment Guide*. Brisbane: Queensland Government

Department of Transport and Main Roads. *Roads in the Wet Tropics Manual*. Brisbane: Queensland Government

Department of Transport and Main Roads. *Significant Environmental Areas Policy*. Brisbane: Queensland Government

Department of Transport and Main Roads. Standard Drawings. Brisbane: Queensland Government

Department of Transport and Main Roads. Technical Note 163 *Third Party Utility Infrastructure Installation in State-Controlled Roads Technical Guidelines*. Brisbane: Queensland Government

Department of Transport and Main Roads. Technical Note 197 *Provision of shade along paths*. Brisbane: Queensland Government

Department of Transport and Main Roads. Technical Note 208 *Managing Slaking and Dispersive Soil risks in transport infrastructure projects*. Brisbane: Queensland Government

Department of Transport and Main Roads. Technical Specification MRTS04 *General Earthworks*. Brisbane: Queensland Government

Department of Transport and Main Roads. Technical Specification MRTS15 *Noise Fences*. Brisbane: Queensland Government

Department of Transport and Main Roads. Technical Specification MRTS16 *Landscape and Revegetation Works*. Brisbane: Queensland Government

Department of Transport and Main Roads. Technical Specification MRTS52 *Erosion and Sediment Control*. Brisbane: Queensland Government

Department of Transport and Main Roads. *Traffic and Road Use Management (TRUM) Manual*. Brisbane: Queensland Government

Department of Transport and Main Roads. Traffic Control Sign TC1112. Brisbane: Queensland Government

Department of Transport and Main Roads. *Transport Noise Management Code of Practice*. Brisbane: Queensland Government

IECA (Australasia). (2008). *Best Practice Erosion and Sediment Control*. International Erosion Control Association (Australasia)

Queensland Government. *Crime Prevention Through Environmental Design Guidelines for Queensland*

Queensland Government. *Environmental Protection Act 1994 (Qld)*

Queensland Government. *Road Maintenance Code of Practice for the Wet Tropics World Heritage Area*

Queensland Government. *State Development Assessment Provisions (SDAP) Guideline State Code 18*

Queensland Government. *Transport Infrastructure Act 1994 (Qld)*

Standards Australia. *AS 2890.5 Parking facilities, Part 5: On-street parking*

Standards Australia. *AS/NZS 2890.6 Parking facilities, Part 6: Off-street parking for people with disabilities*

TransLink. *Public Transport Infrastructure Manual*. Brisbane: Queensland Government

