

SUPERSEDED

Technical Specification

MRTS56 Construction Surveying

March 2021

Copyright

© The State of Queensland (Department of Transport and Main Roads) 2021.

Licence



This work is licensed by the State of Queensland (Department of Transport and Main Roads) under a Creative Commons Attribution (CC BY) 4.0 International licence.

CC BY licence summary statement

In essence, you are free to copy, communicate and adapt this work, as long as you attribute the work to the State of Queensland (Department of Transport and Main Roads). To view a copy of this licence, visit: <https://creativecommons.org/licenses/by/4.0/>

Translating and interpreting assistance



The Queensland Government is committed to providing accessible services to Queenslanders from all cultural and linguistic backgrounds. If you have difficulty understanding this publication and need a translator, please call the Translating and Interpreting Service (TIS National) on 13 14 50 and ask them to telephone the Queensland Department of Transport and Main Roads on 13 74 68.

Disclaimer

While every care has been taken in preparing this publication, the State of Queensland accepts no responsibility for decisions or actions taken as a result of any data, information, statement or advice, expressed or implied, contained within. To the best of our knowledge, the content was correct at the time of publishing.

Feedback

Please send your feedback regarding this document to: tmr.techdocs@tmr.qld.gov.au

Contents

- 1 Introduction 1**
- 2 Definition of terms 1**
- 3 Referenced documents 2**
- 4 Quality system requirements 3**
 - 4.1 Hold Points, Witness Points and Milestones 3
- 5 Surveyor competency 5**
- 6 Receipt of survey information 6**
- 7 Survey control 6**
 - 7.1 Validation of existing survey control prior to Works 6
 - 7.2 Establishing survey control 6
 - 7.2.1 *Survey control for roads and associated Works* 6
 - 7.2.2 *Bridge construction survey control* 8
 - 7.2.3 *Ongoing validation and maintenance* 9
 - 7.2.4 *Naming and coding of survey marks* 9
 - 7.2.5 *Submission of survey control* 9
 - 7.3 Protection of survey marks 9
 - 7.3.1 *Survey control marks and benchmarks* 9
 - 7.3.2 *Secondary control marks* 10
 - 7.3.3 *Cadastral reference mark protection* 10
 - 7.4 Relocation of survey control marks 11
 - 7.5 Identification markers 12
- 8 Validation of existing ground surface prior to Works 12**
 - 8.1 Survey accuracy 12
 - 8.2 Metadata 12
 - 8.2.1 *Project details* 12
 - 8.2.2 *Equipment details* 12
 - 8.2.3 *Time stamp or epoch* 13
- 9 Setting out the Works 13**
 - 9.1 General 13
 - 9.2 Errors in setting out 13
 - 9.3 Earthworks 13
 - 9.3.1 *Stripping of topsoil area* 13
 - 9.3.2 *Excavations* 13
 - 9.3.3 *Embankments* 14
 - 9.4 Pavement, pavement drains, kerbs, channels and kerb and channel 15
 - 9.4.1 *Pavement layers* 16
 - 9.4.2 *Kerb, channel and kerb and channel* 16
 - 9.4.3 *Footpath including pram crossings* 16
 - 9.4.4 *Pavement drains* 17
 - 9.5 Road furniture 17
 - 9.5.1 *Concrete road safety barrier* 17
 - 9.5.2 *Steel beam guardrail* 17
 - 9.5.3 *Proprietary barrier system* 17
 - 9.5.4 *Wire rope barrier* 18
 - 9.5.5 *Road signs* 18

9.5.6	<i>Guide posts</i>	18
9.5.7	<i>Fences</i>	18
9.5.8	<i>Gates</i>	18
9.6	<i>Drainage</i>	18
9.6.1	<i>Drainage systems and culverts</i>	19
9.6.2	<i>Gullies</i>	19
9.6.3	<i>Access chambers</i>	19
9.6.4	<i>Subsoil drains</i>	19
9.6.5	<i>Vertical drains</i>	19
9.7	<i>Subsurface footings and pile caps</i>	19
9.7.1	<i>Retaining wall pad / strip footings</i>	20
9.7.2	<i>Ancillary structure pile footings</i>	20
9.7.3	<i>Noise fence pile / spread footings</i>	20
9.7.4	<i>ITS technologies traffic signal and road lighting footings</i>	21
9.7.5	<i>Load bearing footings</i>	21
9.7.6	<i>Concrete masonry / crib wall footings</i>	21
9.7.7	<i>Pile caps for ancillary structures</i>	21
9.8	<i>Traffic Engineering Technology and Systems (TETS) conduits and pits</i>	21
9.8.1	<i>Conduits</i>	22
9.8.2	<i>Pits</i>	22
9.9	<i>Retaining walls (above ground)</i>	22
9.9.1	<i>Concrete retaining walls</i>	23
9.9.2	<i>Crib walls</i>	23
9.9.3	<i>Boulder walls</i>	23
9.9.4	<i>Reinforced soil structure retaining walls</i>	23
9.9.5	<i>Soil nailing</i>	23
9.9.6	<i>Active rock bolts</i>	23
9.9.7	<i>Passive rock dowels</i>	23
9.10	<i>3rd Party underground assets – Public Utility Plant (PUP)</i>	23
9.11	<i>Bridges</i>	23
9.11.1	<i>Piles</i>	24
9.11.2	<i>Pile caps</i>	24
9.11.3	<i>Columns</i>	24
9.11.4	<i>Abutments and headstocks</i>	24
9.11.5	<i>Coreholes</i>	24
9.11.6	<i>Pedestals / plinths</i>	25
9.11.7	<i>Girders / deck units</i>	25
9.11.8	<i>Deck</i>	25
9.11.9	<i>Kerbs and parapets</i>	25
9.11.10	<i>Relieving slabs</i>	25
10	<i>Compliance / conformance testing</i>	25
10.1	<i>Earthworks and subgrade treatments</i>	25
10.2	<i>Pavement layers</i>	25
10.3	<i>Kerb, channel and kerb and channel</i>	26
10.4	<i>Pavement drains</i>	26
10.5	<i>Noise fences</i>	26
10.6	<i>Drainage</i>	26
10.7	<i>Conduits and pits</i>	26
10.8	<i>Retaining wall footings</i>	26
10.9	<i>Bridges</i>	26
10.9.1	<i>Pile heave</i>	27

10.10	Ancillary structure footings	27
11	As Constructed Survey	27
11.1	Survey at practical completion	27
11.2	Earthworks	28
11.2.1	Topsoil stripped area	28
11.2.2	Bottom of excavation	28
11.2.3	Excavated area of unsuitable material	29
11.2.4	Bottom of excavated areas for end structures	29
11.2.5	Top of embankment (including batters) prior to construction of the subgrade	29
11.2.6	Top of subgrade	29
11.2.7	Bottom of excavations for channels and drains	29
11.3	Pavements, pavement drains, kerb, channel and kerb and channel	29
11.3.1	Top of every pavement layer (non-concrete)	30
11.3.2	Kerb, channel and kerb and channel	31
11.3.3	Footpaths and pram crossings	31
11.3.4	Pavement drains	31
11.3.5	Lean mix concrete sub-base	31
11.3.6	Concrete pavement base	31
11.4	Road furniture	32
11.4.1	Concrete road safety barriers	33
11.4.2	Guard rails	33
11.4.3	Wire rope barrier	33
11.4.4	Road signs / Variable message signs	33
11.4.5	Fences	33
11.4.6	Gates	33
11.4.7	Field cabinets	33
11.4.8	Road light poles and road light poles with mast arms	33
11.4.9	Traffic signal poles and traffic signal poles with mast arms	33
11.4.10	Electricity poles and electricity poles with road lighting mast arms	34
11.4.11	Overhead wires	34
11.5	Drainage	34
11.5.1	Drainage systems and culverts	35
11.5.2	Gullies	35
11.5.3	Access chambers	36
11.5.4	Subsoil drains	38
11.5.5	Vertical drains	38
11.5.6	Attribute information	39
11.6	Subsurface footings	39
11.6.1	Retaining wall pad / strip footings	40
11.6.2	Ancillary structure pile footings	41
11.6.3	Noise fence pile / spread footings	41
11.6.4	ITS Technologies– Traffic signal and road lighting footings	41
11.6.5	Load bearing footings	41
11.6.6	Concrete masonry / Crib wall footings	41
11.7	Traffic Engineering Technology and Systems (TETS)– Conduits and pits	41
11.7.1	Attribute information	42
11.8	Retaining walls (above ground)	42
11.8.1	Concrete retaining walls	43
11.8.2	Crib retaining walls	43
11.8.3	Boulder retaining wall	43
11.8.4	Reinforced soil structure retaining walls	43
11.8.5	Soil nails	43
11.8.6	Active rock bolt	43
11.8.7	Passive rock dowels	44

11.9	Noise fences	44
11.10	Horizontal directional drilling, microtunnelling and thrust boring and auger boring.....	44
11.10.1	Horizontal directional drilling	44
11.10.2	Microtunnelling and pipe jacking	44
11.10.3	Thrust boring and auger boring	45
11.11	3rd Party underground assets – including Public Utility Plant (PUP).....	45
11.12	Bridges.....	46
11.12.1	Piles	46
11.12.2	Pile caps	47
11.12.3	Columns, abutments and headstocks	48
11.12.4	Coreholes	48
11.12.5	Bearing pedestal / plinth.....	49
11.12.6	Girders / deck units.....	49
11.12.7	Deck	50
11.12.8	Kerbs, parapets and relieving slabs	52
12	Compliance / Conformance reporting results	53
12.1	Earthworks	53
12.1.1	Topsoil stripping area	53
12.1.2	Bottom of excavations	54
12.1.3	Excavations for unsuitable material.....	54
12.1.4	Excavation areas for end structures.....	54
12.1.5	Embankments prior to construction of the subgrade.....	55
12.1.6	Stabilised subgrades	55
12.1.7	Excavation for channels and drains	55
12.2	Pavement, pavement drains, kerb, channel and kerb and channel	55
12.2.1	Pavement layers.....	55
12.2.2	Kerb, channel and kerb and channel.....	57
12.2.3	Footpath and pram crossing.....	57
12.2.4	Pavement drains.....	57
12.3	Drainage	57
12.3.1	Drainage systems and culverts	57
12.3.2	Gullies.....	58
12.3.3	Access chambers	58
12.3.4	Subsoil drains	58
12.3.5	Vertical drains.....	58
12.4	Subsurface footings	59
12.4.1	Retaining wall pad / strip footings.....	59
12.4.2	Ancillary structure pile footings.....	60
12.4.3	Noise fence footings.....	60
12.4.4	Traffic signal and road lighting footings.....	60
12.4.5	Load bearing footings.....	60
12.4.6	Concrete masonry / Crib wall footings.....	60
12.5	Conduits and pits	61
12.6	Retaining walls (above ground)	61
12.7	Bridges.....	62
12.7.1	Piles	62
12.7.2	Pile caps, pier columns, abutments and headstocks	62
12.7.3	Bearing pedestals / plinths	66
12.7.4	Girders / deck units.....	66
12.7.5	Deck	67
13	Existing underground assets survey	68
14	Volume surveys	68

14.1 Constructed feature volume..... 68

14.2 Stockpile volume..... 69

15 Deliverables..... 69

16 Surveying deliverable requirements..... 69

17 Supplementary requirements 70

SUPERSEDED

1 Introduction

This Technical Specification applies to the surveying requirements for specific construction types such as; earthworks, pavements, road furniture, underground assets and bridges and structures during civil construction Works for the Department of Transport and Main Roads. For further detailed information on these construction types, refer to the *TMR Surveying Standards*. Construction surveying enables the construction of design elements in the correct location, meeting conformance requirements and undertaking and delivering an As Constructed Survey.

All enquiries regarding surveying requirements to Transport and Main Roads region / district's Principal Surveyor are to be made through the Administrator.

If a region or district does not have a Principal Surveyor, then all enquiries to the Principal Surveyor shall be made through: TMR_Spatial_Enquiry@tmr.qld.gov.au.

This Technical Specification shall be read in conjunction with MRTS01 *Introduction to Technical Specifications*, MRTS50 *Specific Quality System Requirements* and other Technical Specifications as appropriate.

2 Definition of terms

The terms and symbols used in this Technical Specification shall be as defined in Clause 2 of MRTS01 *Introduction to Technical Specifications* and in Table 2 below.

Table 2 – Definition of terms

Term	Definition
As Constructed Survey	As Constructed Surveys are detailed site survey measurements that accurately record details of completed Works. They represent the true shape and size of the real world constructed objects depicting surface shapes in either two or three dimensions (3D) in geospatially referenced location. They also provide descriptive attribute information. The As Constructed Survey can be represented in three dimensional (3D) electronic models.
Cadastral Reference Survey Marks	Cadastral Reference Survey marks are part of the property boundary cadastre.
Control Survey	A Spatial Reference System. A more expansive definition is specified in <i>Standard for the Australian Survey Control Network – SP1 Ver. 2.2</i> (www.icsm.gov.au/).
Culvert	A culvert is a structure that allows water to flow under a road, railway or similar obstruction from one side to another. These can include: <ul style="list-style-type: none"> • pipe culverts, and/or • box culverts.
Drainage system	An underground drainage system can include an underground network system of pipe culverts and/or box culverts connecting between field inlets, gully pits and access chambers that is designed to drain away excess stormwater and ground water. These can include: <ul style="list-style-type: none"> • access chambers • gullies / field inlets • pipe culverts, and • box culverts.

Term	Definition
Permanent Survey Mark	Permanent Survey Marks are substantial marks. The installation and maintenance of Permanent Survey Marks is regulated under the Survey and Mapping Infrastructure Regulation 2014.
Secondary Control Mark	Secondary Control Marks are marks that consist of survey marks and reference marks placed by traversing between survey control marks.
Survey Control Mark	As defined in the <i>Standard for the Australian Survey Control Network – SP1 Version 2.2</i> , a Survey Control Mark is a monument that provides a physical realisation of one or more datums. They are used for survey control networks and Permanent Survey Marks are the preferred type of marks used for Survey Control Marks.
Survey Mark	Survey mark means a survey peg, reference mark, level mark or any other mark for the purpose of setting out, checking or measuring work Under the Contract.

3 Referenced documents

Table 3 lists documents referenced in this Technical Specification.

Table 3 – Referenced documents

Reference	Title
MRTS03	<i>Drainage, Retaining Structures and Protective Treatments</i>
MRTS04	<i>General Earthworks</i>
MRTS05	<i>Unbound Pavements</i>
MRTS06	<i>Reinforced Soil Structures</i>
MRTS07A	<i>Insitu Stabilised Subgrades using Quicklime or Hydrated Lime</i>
MRTS07B	<i>Insitu Stabilised Pavements using Cement or Cementitious Blends</i>
MRTS07C	<i>Insitu Stabilised Pavements using Foamed Bitumen</i>
MRTS08	<i>Plant-Mixed Heavily Bound (Cemented) Pavements</i>
MRTS09	<i>Plant-Mixed Foamed Bitumen Stabilised Pavements</i>
MRTS10	<i>Plant-Mixed Lightly Bound Pavements</i>
MRTS14	<i>Road Furniture</i>
MRTS15	<i>Noise Fences</i>
MRTS30	<i>Asphalt Pavements</i>
MRTS32	<i>High Modulus Asphalt (EME2)</i>
MRTS38	<i>Pavement Drains</i>
MRTS39	<i>Lean Mix Concrete Sub-base for Pavements</i>
MRTS40	<i>Concrete Pavement Base</i>
MRTS50	<i>Specific Quality System Requirements</i>
MRTS62	<i>Bridge Substructure</i>
MRTS63	<i>Cast-In-Place Piles</i>
MRTS63A	<i>Piles for Ancillary Structures</i>
MRTS64	<i>Driven Tubular Steel Piles (with reinforced concrete pile shaft)</i>

Reference	Title
MRTS65	<i>Precast Prestressed Concrete Piles</i>
MRTS66	<i>Driven Steel Piles</i>
MRTS70	<i>Concrete</i>
MRTS73	<i>Manufacture of Prestressed Concrete Members and Stressing Units</i>
MRTS74	<i>Supply and Erection of Prestressed Concrete Deck and Kerb Units</i>
MRTS75	<i>Supply and Erection of Prestressed Concrete Girders</i>
MRTS76	<i>Supply and Erection of Steel Girders</i>
MRTS77	<i>Bridge Deck</i>
MRTS84	<i>Deck Wearing Surface</i>
MRTS91	<i>Conduits and Pits</i>
MRTS92	<i>Traffic Signal and Road Lighting Footings</i>
MRTS93	<i>Traffic Signals</i>
MRTS94	<i>Road Lighting</i>
MRTS140	<i>Horizontal Directional Drilling (HDD)</i>
MRTS141	<i>Microtunnelling and Pipe Jacking</i>
MRTS142	<i>Thrust Boring and Auger Boring</i>
SP1 Ver. 2.2	<i>Standard for the Australian Survey Control Network (www.icsm.gov.au/)</i>
-	<i>Survey and Mapping Infrastructure Act, 2003</i>
-	<i>Survey and Mapping Infrastructure Regulation, 2014</i>
TN163	<i>Third Party Utility Infrastructure Installation in State Controlled Roads Technical Guidelines</i>
TN165	<i>Survey Marks (Transport and Main Roads Surveying Standards – February 2016)</i>
TMR Surveying Standards (February, 2016)	<i>TMR Surveying Standards Part 1 – General Information</i>
	<i>TMR Surveying Standards Part 2 – Geomatic Survey Types</i>
	<i>Schedule 1 – Codes, Linestyles and Examples</i>

4 Quality system requirements

4.1 Hold Points, Witness Points and Milestones

General requirements for Hold Points, Witness Points and Milestones are specified in Clause 5.2 of MRTS01 *Introduction to Technical Specifications*.

There are no Milestones defined.

The Hold Points and Witness Points applicable to this Technical Specification are summarised in Table 4.1.

Table 4.1 – Hold Points, Witness Points and Milestones

Clause	Hold Point	Witness Point	Milestone
6	1. Validation of survey information		

Clause	Hold Point	Witness Point	Milestone
7.1	2. Validation of existing survey control prior to Works		
7.2.5	3. Submission of survey control		
7.3		1. Disturbance or destruction of survey marks	
7.3.2		2. Report historical mark	
7.3.3	4. Cadastral survey reference mark protection prior to noise fence construction		
	5. Cadastral survey reference mark protection prior to retaining wall construction		
	6. Cadastral survey reference mark protection prior to excavations or trenching		
	7. Cadastral survey reference mark protection prior to removal / demolition of kerbs, kerb and channel and concrete slabs		
7.4		3. Relocate survey control mark	
9.2	8. Error in setting out		
11.2.1		4. Survey of topsoil stripped area	
11.2.2		5. Survey bottom of excavation for cuttings	
11.2.3		6. Survey excavation area of unsuitable material	
		7. Survey after backfill	
11.2.4		8. Survey bottom of excavation area for end structures	
11.2.5		9. Survey top of embankment including batters	
11.2.6		10. Survey top of subgrade	
11.3.1		11. Survey top of every pavement layer (non-concrete)	

Clause	Hold Point	Witness Point	Milestone
11.5.1	9. Survey of drainage system and culverts		
11.5.2	10. Survey of gullies		
11.5.3	11. Survey of access chambers		
11.5.4		12. Survey of subsoil drains	
11.5.5		13. Survey of vertical drains	
11.6.1		14. Survey bottom of retaining wall pad / strip excavations	
		15. Survey top of retaining wall pad / strip footings	
11.6.3		16. Survey bottom of noise fence pile / spread excavation	
		17. Survey top of noise fence pile / spread footing	
11.6.4		18. Survey bottom of traffic signal and road lighting footing excavation	
11.6.5		19. Survey load bearing footing excavations	
11.6.6		20. Survey of concrete masonry / crib wall footing excavations	
11.7	12. Survey of TETS conduits and pits		
11.11	13. Survey of 3rd party underground assets – including Public Utility Plant (PUP)		
13	14. Survey of existing underground assets	21. Survey of buried temporary Works	
15		22. Deliverables handover	

5 Surveyor competency

The Contractor:

- a) Must employ a Contractor's Surveyor who must:
 - i. meet the competency requirements as specified in the relevant categories under Section 2.4.3 of the *TMR Surveying Standards, Part 1*, and
 - ii. have the minimum years of experience as specified in the relevant categories under Section 2.4.3 of the *TMR Surveying Standards, Part 1*.

- b) The Contractor's Surveyor must direct and supervise all surveys and must be authorised to discuss and resolve technical surveying related issues on Site.

6 Receipt of survey information

The Surveyor is to check that enough information to enable undertaking survey Works has been received prior to undertaking any survey Works. This can include the Ground and Feature Model (GFM), 12d model or digital model, survey control, plans, drawings, construction specifications, contract documents, annexures, standards and schedules and notice of such validation provided to the Administrator. **Hold Point 1**

7 Survey control

7.1 Validation of existing survey control prior to Works

Prior to construction Works, where existing survey control is provided by the Department of Transport and Main Roads, the Contractor must check all survey control marks, as defined in Clause 7.3.1, for height and any disturbance since installation.

All height checks must be undertaken as prescribed in Section 6.6 of the *TMR Surveying Standards, Part 1*.

If any survey control mark is deemed to be disturbed or required to be relocated as specified in Clause 7.4 or does not meet the accuracy requirements as specified in Table 7.2.1.2, the Contractor is to establish new coordinates and height values as specified in Clause 7.2.

Following all survey control validation activities, the Contractor is to submit to the Administrator with copies to Transport and Main Roads region / district's Principal Surveyor the following: **Hold Point 2**

- results of the validation survey
- all existing survey control mark values that have been accepted and adopted for the work
- any relocated survey control mark values that have been accepted and adopted for the work, and
- obtain any additional survey data necessary for design and any other purposes.

7.2 Establishing survey control

7.2.1 Survey control for roads and associated Works

If survey control is not provided by the Principal or if new survey control is to be established that is fit for purpose for construction surveying, then the following applies:

- a) All survey heights and horizontal co-ordinate systems must match the project coordinate values as listed in the contract drawings. Refer Section 6.4 of *TMR Surveying Standards, Part 2*.
- b) Control survey for the Contractor's work must be conducted in accordance with the recommended survey, and reduction practices specified in *Standard for the Australian Survey Control Network – SP1 Ver. 2.2* and its relevant guidelines (www.icsm.gov.au/).
- c) For the Contractor's work, height control requires that existing Permanent Survey Marks must be supplemented by new Temporary Bench Marks such that the spacing between the Permanent Survey Marks and Temporary Bench Marks is a maximum of 500 m. The practice

for installing Temporary Bench Marks is prescribed in Section 6.5 of *TMR Surveying Standards*, Part 1. Levelling procedure and accuracy of Temporary Bench Marks is specified in Section 6.6 of *TMR Surveying Standards*, Part 1.

7.2.1.1 Resections

Once validation of existing control and/or establishment of survey control has been completed, there are often instances during construction Works where it is acceptable to establish in-fill control by resection methodology. Resection methodology for establishing in-fill control is acceptable under the following conditions:

- Physical marks or remote prism (for example, bolted in a wall or stable structure) must be placed or established. They can be less robust marks than survey control marks (for example, pegs, nails in concrete, and so on), but must be stable, semi-permanent and fit for purpose.
- Observations to a minimum of three survey or secondary control marks on both faces must be measured.
- Angular geometry needs to be sound. Small measurement errors increase the resultant error ellipse rapidly on very narrow angle geometry. Angles less than 10° must not be used.
- Tripod mounted traverse prisms should be used on all survey or secondary control marks.
- Once resected coordinates are calculated, use these values to set out the survey or secondary control marks and compare resultant differences. Accept only if coordinate residuals are within +/- 5 mm.
- Other resected marks must not be used as part of a resection, and
- Once resected values are accepted, a check to another previously set out mark from another survey control point is recommended.

7.2.1.2 Survey control accuracy

Survey control accuracy requirements are specified in Table 7.2.1.2.

Table 7.2.1.2 – Survey accuracy control requirements

Clause	Survey Accuracy	Work activity	H _z Accuracy SU (mm) @ 95% Confidence Level (CL)	H _z Accuracy RU ppm (linear misclose ratio)	Height Accuracy RU (mm) @ 95% Confidence Level (CL) between individual marks	Height Accuracy misclose
7.2.1.2	Survey Control Accuracy	Survey Control Marks	< 15	-	10	12 mm* \sqrt{k}
		Construction Project Survey Control Marks (Secondary Control Marks)	-	30	3	6 mm* \sqrt{k}
7.2.2.1	Bridge Survey Control Accuracy	Bridge Survey Control Marks	≤ 2	-	1.5	6 mm* \sqrt{k}
7.2.1.1	Resections	Resections (Road Construction Survey Control)	≤ 15	-	-	-
7.2.2.1	Bridge Construction Survey Control	Resections (Bridge Survey Control)	≤ 3	-	-	-

The Contractor must verify and accept the construction project survey control for the Contractor's work.

- i. Survey Control Marks – project reference frame marks are the primary on site reference marks for each project. They primarily consist of Permanent Survey Marks (PSM's) and shall have a minimum spacing of 500 m between each other:
 - Horizontal accuracy – unless specified in the drawings or documentation, Survey Uncertainty (SU) of < 0.015 m at 95% confidence level. This value takes precedence over the *TMR Surveying Standards*.
 - Vertical accuracy - unless specified otherwise in the drawings or documentation, the accuracy requirements are as specified for Survey marks in Table 1.3.1.4b, *TMR Surveying Standards, Part 2*.
- ii. Construction project survey control (Secondary control) – construction project survey control shall use as datum, where available, the projects underlying survey control network used to create the project design (that is, the pre-design survey). The preferred method of estimating the Survey Uncertainty (SU) for construction project survey control marks is by applying a minimally constrained adjustment of the construction project survey control network. However, for evaluating the quality of a conventional linear survey traverse, the preferred and suitable means adopted by Transport and Main Roads is to perform a linear misclose adjustment to calculate Relative Uncertainty (RU). Minimum spacing and density between placed construction project control marks should be fit for purpose for the lot under construction and maximum spacing should not exceed 150 m.
 - Horizontal accuracy - unless specified in the drawings or documentation, Relative Uncertainty (RU) < 30 ppm (linear misclose ratio) between individual marks.
 - Vertical accuracy - unless specified in the drawings or documentation, the allowable misclose (in millimetres) as determined by reciprocal level runs must not be greater than $6\text{mm} * \sqrt{k}$ where 'k' is the distance in kilometres.

7.2.2 Bridge construction survey control

There are other exceptions where plan coordinates are based on a plane system rather than a map projection system. These can apply to bridges and structures where the combined scale factor can have a significant impact on construction tolerances. The best practice to adopt in these cases including resections is specified in Section 6.6 Bridge Construction Survey, *TMR Surveying Standards, Part 2*.

7.2.2.1 Bridge survey control accuracy

7.2.2.1.1 Horizontal

The preferred method of estimating the Survey Uncertainty (SU) for bridge survey control marks is by applying a minimally constrained adjustment of the bridge survey control network. Examples of bridge network geometry and measurement criteria can be found in Section 6.6 *TMR Surveying Standards, Part 2*. SU values are specified in Table 7.2.2.1.2.

7.2.2.1.2 Vertical

Independent two way level runs are required on all Bridge Survey Control Marks. The allowable misclose for this level run is $6\text{mm} * \sqrt{\text{km}}$. In addition, the maximum Relative Uncertainty (RU) for heights between adjacent Bridge Survey Control Marks is 1.5 mm.

7.2.3 Ongoing validation and maintenance

Ongoing validation and maintenance of survey control is essential during the construction process, especially after rainfall events and nearby construction activities.

7.2.4 Naming and coding of survey marks

Refer to TN165 *Survey Marks (Transport and Main Roads Surveying Standards – February 2016)* for standardised naming and coding for the different types of survey marks.

7.2.5 Submission of survey control

Submission of survey control validation results are to be provided to the Administrator and Transport and Main Roads region / district's Principal Surveyor prior to commencement of Works. **Hold Point 3**

If a region or district does not have a Principal Surveyor, then all enquiries to the Principal Surveyor shall be made through: [TMR Spatial Enquiry@tmr.qld.gov.au](mailto:TMR_Spatial_Enquiry@tmr.qld.gov.au).

Subsequent to the survey control validation check, if any errors are found with the supplied survey control, then contact the above.

7.3 Protection of survey marks

The Contractor shall keep in their true positions all survey marks specified in the Contract or as supplied by the Administrator.

Prior to undertaking Works, the Contractor shall identify and notify the Administrator of any such survey marks that are at risk of being disturbed or obliterated.

If a survey control mark, as defined in Clause 7.3.1, is disturbed or obliterated, the Contractor shall within one business day notify the Administrator and, unless the Administrator otherwise directs, the Contractor shall reinstate the survey mark in its original or more suitable location. **Witness Point 1**

If the disturbance or obliteration of survey control marks, as defined in Clause 7.3.1, is caused by a person referred to under Site access for the Principal and others under the conditions of the contract, other than the Contractor, the cost incurred by the Contractor in reinstating the survey control mark shall be valued as a variation under the conditions of the contract. The Contractor's attention is directed to the possible existence of survey control marks within or near the Site.

7.3.1 Survey control marks and benchmarks

Survey Control Marks are significant survey marks placed at approximately 1 km intervals and have the highest order of accuracy. These are defined in Section 6.4 of the *TMR Surveying Standards, Part 1*. Destruction, maintenance, and replacement of these marks are controlled under Survey mark protection and by the Survey Control Marks Register as specified in Section 6.4.1 and Section 6.4.2 of the *TMR Surveying Standards, Part 2*. Permanent Survey Marks are the preferred mark to be placed and can also include Benchmarks. The Contractor must avoid where reasonably possible disturbance of Survey Control Marks and Benchmarks and must re-establish any Survey Control Marks and Benchmarks disturbed or affected by the Contractor's work. Prior to the commencement of work and if

subsequently requested by the Administrator, the Contractor must inform in writing to the Administrator and Transport and Main Roads region / district's Principal Surveyor of any:

- i. proposed changes to any Survey Control Marks or Benchmarks, or
- ii. proposed destruction of any Survey Control Marks or Benchmarks.

7.3.1.1 Placement and recording of permanent survey marks

Section 14(2) of the Survey and Mapping Infrastructure Regulation 2014 Part 4 states that:

'A person must not place or reinstate a permanent survey mark for a survey unless the person is:

- a) a surveyor, or
- b) a person supervised by a surveyor.'

7.3.2 Secondary control marks

Secondary Control marks may consist of survey marks and reference marks that have been previously placed by traversing between survey control marks. Destruction, maintenance, and replacement for these marks are controlled under Survey Mark Protection and by the Survey Control Marks Register Section 6.4.1 and Section 6.4.2 of the *TMR Surveying Standards, Part 2*. Reference marks in urban areas require additional care.

The Contractor must report historical survey marks (protected under the *Survey and Mapping Infrastructure Act, 2003*) such as blazed trees or bench marks to the Administrator who will obtain and provide management guidance that the Contractor must implement. **Witness Point 2**

7.3.3 Cadastral reference mark protection

Destruction, maintenance, and replacement for these marks are controlled under Survey Mark Protection and by the Survey Control Marks Register Section 6.4.1 Survey Mark Protection and Section 6.4.2 Survey Control Register of the *TMR Surveying Standards, Part 2*.

An assessment is to be undertaken to identify cadastral marks that may need protecting prior to excavations for:

- a) Footings to be undertaken in accordance with MRTS15 *Noise Fences* and notice of such Works provided to the Administrator and Transport and Main Roads region / district's Principal Surveyor. **Hold Point 4**
- b) Construction of retaining walls undertaken in accordance with MRTS03 *Drainage, Retaining Structures and Protective Treatments*. If the assessment deems it necessary, a survey for identifying and protecting cadastral survey marks shall be undertaken as specified in Table 7.3.3 and notice of such Works provided to the Administrator and Transport and Main Roads region / district's Principal Surveyor. **Hold Point 5**
- c) Earthwork cuttings or trenching Works undertaken in accordance with MRTS04 *General Earthworks* and/or TN163 *Third Party Utility Infrastructure Installation in State-Controlled Roads Technical Guidelines*. If the assessment deems it necessary, a survey for identifying and protecting cadastral survey marks shall be undertaken as specified in Table 7.3.3 and notice of such Works provided to the Administrator and Transport and Main Roads region / district's Principal Surveyor. **Hold Point 6**

- d) Where removal / demolition of kerbs, kerbs and channel and concrete slabs are to be removed in accordance with MRTS03 *Drainage, Retaining Structures and Protective Treatments* or where specified in the drawings, an assessment survey for identifying and protecting of cadastral survey marks shall be undertaken as specified in Table 7.3.3 and notice of Works provided to the Administrator and Transport and Main Roads region / district's Principal Surveyor. **Hold Point 7**

Enquiries regarding assessments can be obtained through Transport and Main Roads region / district's Principal Surveyor.

Table 7.3.3 – Cadastral reference mark protection

Clause	Cadastral reference mark protection survey	Work Activity
7.3.3	Noise Fence footings	Identification and protection of cadastral reference marks shall be undertaken by a Cadastral Surveyor prior to excavation Works as directed by Transport and Main Roads region / district's Principal Surveyor.
	Retaining wall footings	
	Excavation Works for cuttings or trenching	
	Removal / demolition of kerbs, kerb and channel and concrete slabs	

7.3.3.1 How to protect survey marks

A cadastral surveyor should be engaged to determine the likelihood of any survey marks being interfered with on a construction project. This is achieved by the surveyor carrying out a cadastral search and review of the proposed Works and potential impact on any survey marks and property boundaries in the vicinity. If marks will be interfered with, then an Identification Survey plan (Ident Plan) may need to be completed well in advance of any Works commencing. This pre-construction Ident Plan physically locates and verifies the existence of any cadastral survey marks and permanent survey marks (PSMs) within the corridor, and places additional survey marks in safe locations surrounding the work site as recovery marks. This Ident Plan is lodged with the Department of Resources as a record of survey available on the public register. Any PSMs shown as 'gone' on the Ident Plan will be updated in the Survey Control Database (SCDB) as being 'not found'.

Depending on the size and nature of the project and once all Works are completed, a post construction Ident survey may be required to re-establish sufficient cadastral survey marks and PSMs in suitable locations throughout the completed construction site to facilitate future and efficient reinstatement of property boundaries. This post-construction Ident Plan would also be lodged with the Department of Resources. If PSMs are disturbed or adversely affected from construction, further surveys may be required to coordinate and/or level PSMs to suitably re-establish the pre-construction horizontal and vertical control networks.

7.4 Relocation of survey control marks

If the Contractor wishes to relocate an existing Survey control mark, the Administrator shall be notified in writing at least five business days prior to such intended relocation. **Witness Point 3**

The notice shall include a description of the proposed method for coordinating and levelling the new survey mark. If another Authority's survey mark is involved, the Contractor shall also obtain written

approval from the other Authority and submit a copy of such approval to the Administrator and to Transport and Main Roads region / district's Principal Surveyor.

7.5 Identification markers

The Contractor shall place identification markers at a minimum of 100 m spacing along each control line for road centrelines and adjacent to each tangent point. Such markers shall show the chainage and any other relevant information. All identification markers must be placed as specified unless directed otherwise by the Administrator.

8 Validation of existing ground surface prior to Works

Prior to breaking ground, if the Contractor wishes to dispute the existing ground surface terrain model, then this shall be done in accordance with MRS04 *General Earthworks*.

The Contractor shall provide validation of the survey control information to the Administrator. See Clause 7.2.5.

If a sample survey of set of points is required in accordance with MRS04 *General Earthworks*, the Contractor shall undertake this survey to the accuracy requirements specified in Clause 8.1. The survey information provided to the Administrator should show height differences between surveyed points and the original surface terrain model. Any points that exceed the values specified in Table 1.3.1.4c *Interpolated heights* of the *TMR Surveying Standards, Part 2* should be highlighted.

If an additional independent ground survey of the disputed area is required in accordance with MRS04 *General Earthworks*, the Contractor shall undertake this survey to the accuracy requirements specified in Clause 8.1.

8.1 Survey accuracy

The Contractor must verify and accept the accuracy of the existing ground surface types for the Contractor's work as follows:

- i. Horizontal - must meet accuracy requirements as specified for the various ground surface types in Table 1.3.1.4a, *TMR Surveying Standards, Part 2*, and
- ii. Vertical – must meet accuracy requirements as specified for the various ground surface types in Table 1.3.1.4b, *TMR Surveying Standards, Part 2*.

8.2 Metadata

All survey information / data that is captured and provided to Transport and Main Roads must provide metadata.

8.2.1 Project details

Include all relevant project details including:

- Project description
- Location, and
- Surveyor details.

8.2.2 Equipment details

Include all equipment details.

8.2.3 Time stamp or epoch

Observation epoch (time at which the data was observed or measured) and Coordinate epoch (the time at which coordinates are referenced) must be recorded in order to unambiguously define the position of a feature at a particular point in time.

Note that Observation epoch (date of capture) and Coordinate epoch (stored explicitly against the Coordinate Reference System (CRS) such as GDA94 or GDA2020) should be stored independently from each other.

9 Setting out the Works

9.1 General

Setting out of all items shown on the drawings or listed in the Contract is the responsibility of the Contractor. For identification markers, see Clause 7.5.

9.2 Errors in setting out

If the Contractor discovers an error in the position, level, dimensions or alignment of any work under the Contract, the Contractor shall within one business day notify the Administrator and, unless the Administrator otherwise directs, the Contractor shall rectify the error. **Hold Point 8**

If the error has been caused by incorrect survey marks supplied by the Administrator, the cost incurred by the Contractor in rectifying the error shall be valued as a variation under the conditions of the contract.

9.3 Earthworks

All setting out activities for earthworks including survey accuracy are specified in Table 9.3.

Table 9.3 – Setting out requirements for earthworks

Clause	Setting out	Work activity	Accuracy* Hz & Vt (mm)
9.3.1	Topsoil stripping area	As per marked out on the drawings at minimum of 20 m intervals. Or if undertaken by machine guidance then using Global Navigation Satellite Systems (GNSS) is acceptable.	± 50
9.3.3	Excavations	Includes: Control lines, toe of batter at subgrade level and batter interfaces (catch points) and all at minimum of 20 m intervals including tangent points and as specified on the drawings. Or if Works undertaken by machine guidance, undertake independent checks using alternative measurement techniques to achieve ± 25 mm accuracy at minimum 100 m intervals.	± 25

* Accuracies are stated in terms of 'relative uncertainty' at 95% confidence level.

9.3.1 Stripping of topsoil area

The stripping of topsoil area shall be set out in accordance with the shapes, lines, and other requirements shown on the drawings and in accordance with MRTS04 *General Earthworks*.

9.3.2 Excavations

Excavations shall be set out in accordance with the shapes, lines, dimensions and other requirements shown on the drawings and in accordance with MRTS04 *General Earthworks*. If the ground height at

the location of the design batter interface (catch point) does not match the actual ground height, the catch point shall be adjusted accordingly (by multiplying the height difference by the batter slope gradient).

If the batter slope is higher (that is, exceeding the values specified in Table 1.3.1.4c *Interpolated heights* of the *TMR Surveying Standards, Part 2*) than the design location, or if the catch point encroaches inside the property boundary (see Figure 9.3.2), then notice of such shall be provided to the Administrator.

Figure 9.3.2 – Excavation catch point

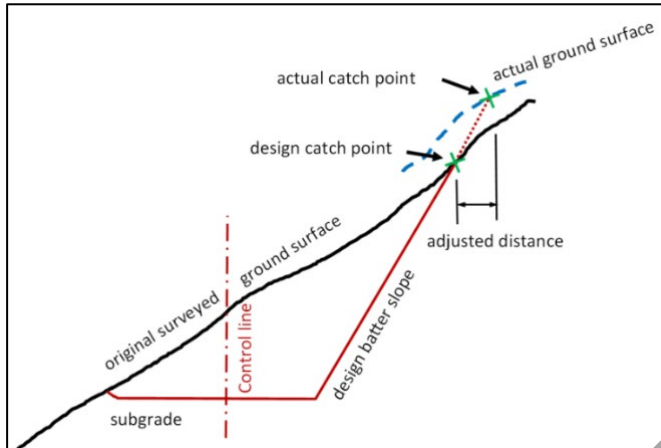

9.3.3 Embankments

Embankments shall be set out in accordance with the shapes, lines, dimensions and other requirements shown on the drawings and in accordance with MRTS04 *General Earthworks*. If the ground height at the location of the design batter interface (catch point) does not match the actual ground height, the catch point shall be adjusted accordingly (by multiplying the height difference by the batter slope gradient). If the batter slope is lower (that is, exceeding the values specified in Table 1.3.1.4c *Interpolated heights* of the *TMR Surveying Standards, Part 2*) than the design location, or if the catch point encroaches inside the property boundary (see Figure 9.3.3), then notice of such shall be provided to the Administrator.

Note: To measure within tolerance, the measurement accuracy requirements must be better than the tolerance requirements. The survey accuracy requirements are at least half that of the tolerance specification.

Figure 9.3.3 – Embankment catch point

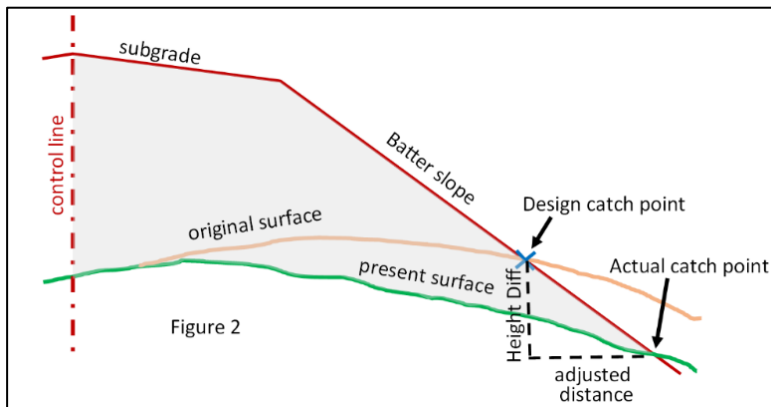

9.4 Pavement, pavement drains, kerbs, channels and kerb and channel

All setting out activities for pavement layers, pavement drains, kerb, channel and kerb and channel including survey accuracy are specified in Table 9.4.

Table 9.4 – Setting out requirements for pavement, pavement drains, kerb, channel and kerb and channel

Clause	Setting out	Work activity	Accuracy* Hz (mm)	Accuracy* Vt (mm)	
9.4.1	Insitu Stabilised Pavements using Cement or Cementitious Blends	Use horizontal and vertical geometry of control alignments and as specified on the drawings to set out at a minimum of 20 m intervals all edges, changes in grade, crown, crests and dips in vertical geometry including tangent points. If using Machine Guidance, setting out of suitable fit for purpose independent stable marks in suitable locations should be installed for height control checks.	± 25	-2 and +5	
	Insitu Stabilised Pavements using Foamed Bitumen				
	Plant-Mixed Foamed Bitumen Stabilised Pavements				
		Lean Mix Concrete Sub-base for Pavements	Use horizontal and vertical geometry of control alignments and as specified on the drawings to set out at a minimum of 20 m intervals all edges, changes in grade, crown, crests and dips in vertical geometry including tangent points. If using Machine Guidance, setting out of suitable fit for purpose independent stable marks in suitable locations should be installed for height control checks.	± 10	± 5
		Unbound pavement	Use horizontal and vertical geometry of control alignments and as specified on the drawings to set out at a minimum of 20 m intervals all edges, changes in grade, crown, crests and dips in vertical geometry including tangent points. If using Machine Guidance, setting out of suitable fit for purpose independent stable marks in suitable locations should be installed for height control checks.	± 25	± 5
		Plant-Mixed Heavily Bound (Cemented) Pavements			
		Plant-Mixed Lightly Bound Pavements			
	Asphalt Pavements				
	High Modulus Asphalt (EME2)				
	Concrete Pavement Base	± 10	-2 and +10		
9.4.2	Cast-in-Place Concrete kerb, Channel, and Kerb and Channel	Use horizontal and vertical geometry of control alignments (in particular, the kerb lip line), including tangent points and as specified on the drawings. Set out in sufficient detail to suit site conditions. And set out marks adjacent to proposed traffic and road lighting footings to ensure tolerances are met for height clearance of hold down bolts.	± 5	± 5	
	Precast Concrete Kerb, Channel, and Kerb and Channel				

Clause	Setting out	Work activity	Accuracy* Hz (mm)	Accuracy* Vt (mm)
9.4.3	Footpaths including Pram Crossings	Use horizontal and vertical geometry of control alignments, including tangent points and as specified on the drawings. Set out in sufficient detail to suit Site conditions.	± 10	± 5
9.4.4	Pavement Drains	Use horizontal and vertical geometry as specified on the drawings (invert). * Gradient shall not be less than 0.5%.	± 25	± 15*
		Use horizontal and vertical geometry as specified on the drawings (upper surface of drain).	± 25	± 5

* Accuracies are stated in terms of 'relative uncertainty' at 95% confidence level.

9.4.1 Pavement layers

All pavement layers for the construction of subbase, base and pavement surface shall be set out in accordance with the shapes, lines, dimensions and other requirements shown on the drawings and in accordance with MRTS05 *Unbound Pavements*, MRTS07B *Insitu Stabilised Pavements using Cement or Cementitious Blends*, MRTS07C *Insitu Stabilised Pavements using Foamed Bitumen*, MRTS08 *Plant-Mixed Heavily Bound (Cemented) Pavements*, MRTS09 *Plant-Mixed Foamed Bitumen Stabilised Pavements*, MRTS10 *Plant-Mixed Lightly Bound Pavements*, MRTS30 *Asphalt Pavements*, MRTS32 *High Modulus Asphalt (EME2)*, MRTS39 *Lean Mix Concrete Sub-base for Pavements* and MRTS40 *Concrete Pavement Base*.

Figure 9.4.1 – Pavement layers

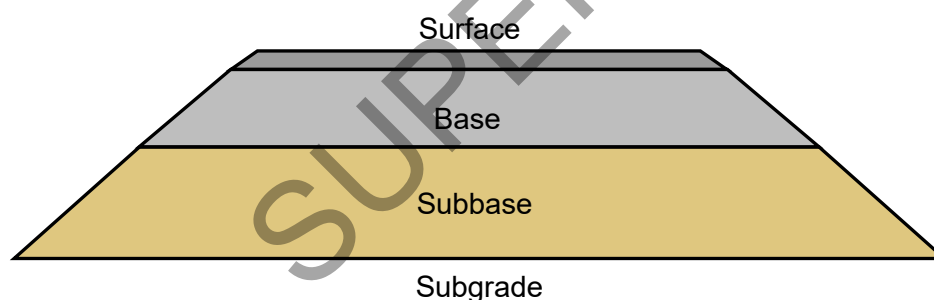

9.4.2 Kerb, channel and kerb and channel

Kerbs, channels and kerb and channel shall be set out in accordance with the lines, dimensions and other requirements shown on the drawings and in accordance with MRTS03 *Drainage, Retaining Structures and Protective Treatments*.

9.4.3 Footpath including pram crossings

Footpaths shall be set out in accordance with the lines, dimensions and other requirements shown on the drawings and documentation and in accordance with hand-placed concrete paving in MRTS03 *Drainage, Retaining Structures and Protective Treatments*.

9.4.4 Pavement drains

Pavement drains shall be set out in accordance with the lines, dimensions and other requirements shown on the drawings and in accordance with MRTS38 *Pavement Drains*.

9.5 Road furniture

All setting out activities for road furniture including survey accuracy are specified in Table 9.5.

Table 9.5 - Setting out requirements for road furniture

Clause	Setting out	Work activity	Accuracy* Hz (mm)	Accuracy* Vt (mm)
9.5.1	Concrete Road Safety Barrier	Horizontal and vertical geometry of control alignments as specified on the drawings and documentation.	± 25	
9.5.2	Guard Rail Posts	As specified on the drawings and documentation.	± 25	
	Steel Beam Guardrail	Horizontal and vertical geometry of control alignments as specified on the drawings and documentation.	± 25	± 5
9.5.3	Proprietary Barrier Systems	Use horizontal and vertical geometry of control alignments, and as specified on the drawings and documentation.	± 25	± 5
9.5.4	Wire Rope Barrier	As specified on the drawings and documentation.	± 25	
9.5.5	Road Signs / Project Signs	As specified on the drawings and documentation.	± 25	
9.5.6	Guide Posts	As specified on the drawings and documentation.	± 25	
9.5.7	Fencing	As specified on the drawings and documentation.	± 25	
9.5.8	Gates	As specified on the drawings and documentation.	± 25	

* Accuracies are stated in terms of 'relative uncertainty' at 95% confidence level.

9.5.1 Concrete road safety barrier

Concrete road safety barriers shall be set out in accordance with the lines, dimensions and other requirements shown on the drawings and in accordance with MRTS14 *Road Furniture*.

9.5.2 Steel beam guardrail

Steel beam guardrails including posts and guardrail shall be set out in accordance with the lines, dimensions and other requirements shown on the drawings and in accordance with MRTS14 *Road Furniture*.

9.5.3 Proprietary barrier system

Proprietary barrier systems shall be set out in accordance with the lines, dimensions and other requirements shown on the drawings and in accordance with MRTS14 *Road Furniture*.

9.5.4 Wire rope barrier

Wire barrier systems shall be set out in accordance with the lines, dimensions and other requirements shown on the drawings and in accordance with MRTS14 *Road Furniture*.

9.5.5 Road signs

Road signs shall be set out in accordance with the location details, dimensions and other requirements shown on the drawings, documentation and in accordance with MRTS14 *Road Furniture*.

9.5.6 Guide posts

Guide posts shall be set out in accordance with the location details, dimensions and other requirements shown on the drawings, documentation and in accordance with MRTS14 *Road Furniture*.

9.5.7 Fences

Fences shall be set out in accordance with the location details, dimensions and other requirements shown on the drawings, documentation and in accordance with MRTS14 *Road Furniture*.

9.5.8 Gates

Gates shall be set out in accordance with the location details, dimensions and other requirements shown on the drawings, documentation and in accordance with MRTS14 *Road Furniture*.

9.6 Drainage

All setting out activities for drainage including survey accuracy are specified in Table 9.6.

Table 9.6 - Setting out requirements for drainage Works

Clause	Setting out	Work activity	Accuracy* Hz (mm)	Accuracy* Vt (mm)
9.6.1	Drainage Systems and Culverts	Set out location of culverts	± 50	-
		Set out invert of culvert *provided that grade shall not depart from those specified by more than 1%.	-	± 5*
9.6.2	Concrete Gullies	Set out horizontal location of concrete gullies in direction of construction centreline.	± 50	-
		Set out horizontal location of concrete gullies at right angles to construction centreline.	± 25	-
		Set out invert of concrete gullies.	-	± 25
		Set out heights at top of back-units, grates and frames.	-	± 5
9.6.2	Precast Concrete Side Inlet Gullies	Set out location of concrete side inlet gullies.	± 5 *	± 5 *
		*Notwithstanding that alignments of side inlet gully shall have smooth lines.		

Clause	Setting out	Work activity	Accuracy* Hz (mm)	Accuracy* Vt (mm)
9.6.3	Insitu Concrete Access Chambers and Precast Concrete Access Chambers	Set out horizontal location of insitu concrete access chamber.	± 50	-
		Set out invert of insitu concrete access chamber * provided that it joins neatly to existing drainage structures and are at heights compatibility with other adjacent structures.	-	± 25 *
		Set out heights on tops of frames, surrounds and covers.	-	± 5
9.6.5	Vertical Drains	Set out location of vertical drains.	± 100	-

* Accuracies are stated in terms of 'relative uncertainty' at 95% confidence level.

9.6.1 Drainage systems and culverts

Drainage systems and culverts shall be set out in accordance with the lines, dimensions and other requirements shown on the drawings, documentation and in accordance with MRTS03 *Drainage, Retaining Structures and Protective Treatments* and Clause 8 MRTS01 *Introduction to Technical Specifications*.

9.6.2 Gullies

Concrete gullies and precast concrete side inlet gullies shall be set out in accordance with the lines, dimensions and other requirements shown on the drawings, documentation and in accordance with MRTS03 *Drainage, Retaining Structures and Protective Treatments* and Clause 8 MRTS01 *Introduction to Technical Specifications*.

9.6.3 Access chambers

Access chambers shall be set out in accordance with the lines, dimensions and other requirements shown on the drawings, documentation and in accordance with MRTS03 *Drainage, Retaining Structures and Protective Treatments* and Clause 8 MRTS01 *Introduction to Technical Specifications*.

9.6.4 Subsoil drains

Subsoil drains shall be set out in accordance with the lines, dimensions and other requirements shown on the drawings, documentation and in accordance with MRTS03 *Drainage, Retaining Structures and Protective Treatments* and Clause 8 MRTS01 *Introduction to Technical Specifications*.

9.6.5 Vertical drains

Vertical drains shall be set out in accordance with the lines, dimensions and other requirements shown on the drawings, documentation and in accordance with MRTS03 *Drainage, Retaining Structures and Protective Treatments* and Clause 8 MRTS01 *Introduction to Technical Specifications*.

9.7 Subsurface footings and pile caps

All setting out activities for Subsurface Footings including survey accuracy are specified in Table 9.7.

The Surveyor should also check that any proposed footings do not clash with any existing or proposed underground assets (for example, subsequent drainage Works).

Table 9.7 - Setting out requirements for subsurface footings and pile caps

Clause	Setting out	Work activity	Accuracy* Hz (mm)	Accuracy* Vt (mm)
9.7.1	Retaining Wall Pad / Strip Footings	Set out location, dimensions and height of pad / strip footings.	± 5	± 10
9.7.2	Ancillary Pile Structure Footing	Set out location of footing. Set out height location once constructed.	± 35	± 3
9.7.3	Noise Fence Pile / Spread Footings	Set out location of pile / spread footings and dimensions of spread footings. Ensure centre to centre distance between posts meets horizontal accuracy requirements. Top of footing must be higher than ground level.	+5 and -0	± 10
9.7.4	ITS Technologies Traffic Signal and Road Lighting Footings	Set out for traffic signal and road lighting footings.	± 10	-
		Set out holding down bolts of traffic signal and road lighting footings as per appropriate Standard Drawing.	-	± 3
9.7.5	Load Bearing Footings	Set out location, and dimensions for excavation Works.	± 25	± 10
9.7.6	Concrete and Masonry Retaining Wall Footings	Set out location & height of footings.	± 5	± 10
9.7.6	Crib Wall Footings	Set out location & height of footings.	± 10	± 10
9.7.7	Pile Caps for Ancillary Structures	Set out location and dimensions of pile caps.	± 10	± 5

* Accuracies are stated in terms of 'relative uncertainty' at 95% confidence level.

9.7.1 Retaining wall pad / strip footings

Retaining wall pad / strip footings shall be set out in accordance with the lines, dimensions and other requirements shown on the drawings, documentation and in accordance with MRTS03 *Drainage, Retaining Structures and Protective Treatments* and Clause 8 MRTS01 *Introduction to Technical Specifications*.

9.7.2 Ancillary structure pile footings

Ancillary structure footings used for such applications as sign gantries, retaining walls, road barriers, pad footings, light poles, masts, hoardings, advertising boards and other ancillary structures shall be set out in accordance with the details specified in the drawings, documentation and in accordance with MRTS63A *Piles for Ancillary Structures* and Clause 8 MRTS01 *Introduction to Technical Specifications*.

9.7.3 Noise fence pile / spread footings

Noise fence pile / spread footings shall be set out in accordance with the details specified in the drawings, documentation and in accordance with MRTS15 *Noise Fences* and Clause 8 MRTS01 *Introduction to Technical Specifications*.

9.7.4 ITS technologies traffic signal and road lighting footings

ITS Technologies traffic signal and road lighting footings shall be set out in accordance with the details specified in the drawings, documentation and in accordance with MRTS92 *Traffic Signal and Road Lighting Footings* and Clause 8 MRTS01 *Introduction to Technical Specifications*.

9.7.5 Load bearing footings

Excavation detail for Load Bearing Footings shall be set out in accordance with the dimensions and depths shown on the drawings and in accordance with MRTS04 *General Earthworks* and Clause 8 MRTS01 *Introduction to Technical Specifications*.

9.7.6 Concrete masonry / crib wall footings

Concrete masonry / crib wall footings location shall be set out in accordance with the details specified in the drawings, and in accordance with MRTS03 *Drainage, Retaining Structures and Protective Treatments* and Clause 8 MRTS01 *Introduction to Technical Specifications*.

9.7.7 Pile caps for ancillary structures

The location and dimensional requirements for pile caps shall be set out in accordance with the details specified in the drawings, and in accordance with MRTS63A *Piles for Ancillary Structures* and MRTS70 *Concrete*.

9.8 Traffic Engineering Technology and Systems (TETS) conduits and pits

All setting out activities for TETS Conduits and Pits including survey accuracy are specified in Table 9.8.

Table 9.8 - Setting out requirements for conduits and pits (TETS)

Clause	Setting out	Work activity	Accuracy* Hz (mm)	Accuracy* Vt (mm)
9.8.1	Allocated corridors, design surface heights and other geometric designs	Set out allocated corridors, design surface heights and design subgrade surface heights and geometric design of other geometric design (for example, drainage and pole footings).	± 10	± 50
9.8.1	Conduits	Generally, locations of conduits shown on the Standard Drawings are indicative only and set out to best suit site conditions including within allocated corridors and avoiding clashes with other geometric designs.	N/A	± 50
9.8.2	Pits	Set out pits in the locations shown on the standard drawings or described elsewhere in the contract. And to suit site conditions including previous set out constraints.	± 10	-
9.8.1	Allocated corridors, design surface heights and other geometric designs	Set out allocated corridors, design surface heights & design subgrade surface heights and geometric design of other geometric design (for example, drainage & pole footings).	± 10	± 50

* Accuracies are stated in terms of 'relative uncertainty' at 95% confidence level.

9.8.1 Conduits

Prior to setting out of conduits, setting out of allocated corridors, design surface heights and design subgrade surface heights and geometric design of other geometric design (for example, drainage and pole footings) shall be undertaken in accordance with the section on Underground Assets, Part 2 *TMR Surveying Standards*. This work is undertaken to ensure construction conformance requirements and identify potential clashes.

Conduits shall be set out in the locations shown on the standard drawings or described elsewhere in the Contract. Generally, locations of conduits are indicative only and set out best to suit site conditions and in accordance with MRTS91 *Conduits and Pits* and Clause 8 MRTS01 *Introduction to Technical Specifications*. Generally, setting out of conduits is not required to be set out by a Surveyor.

9.8.2 Pits

Pits shall be set out in the locations shown on the standard drawings or described elsewhere in the contract. Generally, locations of pits are indicative only and set out best to suit site conditions and in accordance with MRTS91 *Conduits and Pits* and Clause 8 MRTS01 *Introduction to Technical Specifications*.

9.9 Retaining walls (above ground)

All setting out activities for concrete retaining walls, crib walls, boulder walls, soil nailing, passive rock dowels and active rock bolts including survey accuracy are specified in Table 9.9.

Table 9.9 - Setting out requirements for retaining walls (above ground) and soil nail walls

Clause	Setting out	Work activity	Accuracy* Hz (mm)	Accuracy* Vt (mm)
9.9.1	Concrete Retaining Walls	Set out location on top of concrete retaining wall.	± 5	-
		*Except where it is required to join neatly to adjacent structures.	-	± 10 *
9.9.2	Crib Walls	Set out location on alignment of crib wall.	± 10	
		*Except where it is required to join neatly to adjacent structures.	-	± 10 *
9.9.3	Boulder Walls	Set out location on front face of wall.	± 75	-
9.9.4	Reinforced Soil Structures	Set out location of front face of wall.	± 25	± 15 *
		*Except ± 5 where adjacent to bridge abutments.		
9.9.5	Soil Nailing	Soil nails shall be set out in the locations and, if required, in accordance with the details specified in the drawings to ensure that the front end of the soil nails and rock bolts meet tolerance requirements.	Drawing specific	Drawing specific
9.9.6	Active Rock Bolts	Active rock bolts shall be set out in the locations and in accordance with the details specified in the drawings.	Drawing specific	Drawing specific

Clause	Setting out	Work activity	Accuracy* Hz (mm)	Accuracy* Vt (mm)
9.9.7	Passive Rock Dowels	Passive rock dowels shall be set out in the locations and in accordance with the details specified in the drawings.	Drawing specific	Drawing specific

* Accuracies are stated in terms of 'relative uncertainty' at 95% confidence level.

9.9.1 Concrete retaining walls

Concrete retaining walls shall be set out in accordance with the lines, dimensions and other requirements shown on the drawings, documentation and in accordance with MRTS03 *Drainage, Retaining Structures and Protective Treatments* and Clause 8 MRTS01 *Introduction to Technical Specifications*.

9.9.2 Crib walls

Crib walls shall be set out in accordance with the lines, dimensions and other requirements shown on the drawings, documentation and in accordance with MRTS03 *Drainage, Retaining Structures and Protective Treatments* and Clause 8 MRTS01 *Introduction to Technical Specifications*.

9.9.3 Boulder walls

Boulder walls shall be set out in accordance with the lines, dimensions and other requirements shown on the drawings, documentation and in accordance with MRTS03 *Drainage, Retaining Structures and Protective Treatments* and Clause 8 MRTS01 *Introduction to Technical Specifications*.

9.9.4 Reinforced soil structure retaining walls

Reinforced Soil Structure retaining walls shall be set out in accordance with the lines, dimensions and other requirements shown on the drawings, documentation and in accordance with MRTS06 *Reinforced Soil Structures* and Clause 8 MRTS01 *Introduction to Technical Specifications*.

9.9.5 Soil nailing

Soil nailing shall be set out in the locations and in accordance with the details specified in the drawings and in accordance with MRTS03 *Drainage, Retaining Structures and Protective Treatments*.

9.9.6 Active rock bolts

Rock bolts shall be set out in the locations and in accordance with the details specified in the drawings and in accordance with MRTS03 *Drainage, Retaining Structures and Protective Treatments*.

9.9.7 Passive rock dowels

Rock dowels shall be set out in the locations and in accordance with the details specified in the drawings and in accordance with MRTS03 *Drainage, Retaining Structures and Protective Treatments*.

9.10 3rd Party underground assets – Public Utility Plant (PUP)

Unless explicitly specified in other contractual arrangements, setting out requirements for 3rd party assets is generally undertaken by the relevant utility authorities and is out of scope in this document.

9.11 Bridges

Abutments and piers shall be set out on the site by a surveyor experienced in bridge construction in accordance with MRTS62 *Bridge Substructure*.

All setting out activities for bridges including survey accuracy are specified in Table 9.11.

Table 9.11 - Setting out requirements bridges

Clause	Setting out	Work activity	Accuracy* Hz (mm)	Accuracy* Vt (mm)
7.2.2	Bridge Survey Control & Pier Control lines	Refer to Clause 7.2.2.	SU \leq 2 mm @95% CI	RU 1.5 mm @ 95% CI
9.11.1	Piles	Set out from Bridge Survey Control and Pier Control lines.	\pm 35	\pm 5
9.11.2	Pile Caps	For best practice, set out Pile caps, Abutments, Headstocks and Core holes as recommended in Clause 6.6.9.4 and 6.6.9.5 as prescribed in the <i>TMR Surveying Standards, Part 2</i>	\pm 10	\pm 5
9.11.3	Columns		\pm 3	\pm 3
9.11.4	Abutments and Headstocks		\pm 3	\pm 3
9.11.5	Core Holes		\pm 3	-
9.11.6	Pedestals / Plinths		\pm 3	\pm 1.5
9.11.7	Girders / Deck Units	Set out from Bridge Survey Control and Pier Control lines.	\pm 3	-
9.11.7	Deck	Set out from Bridge Survey Control line.	\pm 3	\pm 3
9.11.8	Kerbs and Parapets	Set out from Bridge Survey Control line.	\pm 3	-
9.11.8	Relieving Slabs	Set out from Bridge Survey Control line.	\pm 5	\pm 5

* Accuracies are stated in terms of 'relative uncertainty' at 95% confidence level unless stated otherwise.

9.11.1 Piles

Piles shall be set out in accordance with MRTS62 *Bridge Substructure*, MRTS63 *Cast in Place Piles*, MRTS64 *Driven Tubular Steel Piles (with reinforced concrete pile shaft)*, MRTS65 *Precast Prestressed Concrete Piles* or MRTS66 *Driven Steel Piles* and other requirements shown on the drawings and documentation.

9.11.2 Pile caps

Pile caps shall be set out in accordance with accordance with MRTS62 *Bridge Substructure* and MRTS70 *Concrete* and other requirements shown on the drawings and documentation.

9.11.3 Columns

Columns shall be set out in accordance with MRTS62 *Bridge Substructure* and MRTS70 *Concrete* and other requirements shown on the drawings and documentation.

9.11.4 Abutments and headstocks

Abutments and headstocks shall be set out in accordance with MRTS62 *Bridge Substructure* and MRTS70 *Concrete* and other requirements shown on the drawings and documentation.

9.11.5 Coreholes

Coreholes shall be set out in accordance with MRTS62 *Bridge Substructure* and MRTS70 *Concrete* and other requirements shown on the drawings and documentation.

9.11.6 Pedestals / plinths

Pedestal / plinths shall be set out in accordance with MRTS62 *Bridge Substructure* and MRTS70 *Concrete* and other requirements shown on the drawings and documentation.

9.11.7 Girders / deck units

Girders / deck units shall be set out in accordance with MRTS70 *Concrete*, MRTS74 *Supply and Erection of Prestressed Concrete Deck and Kerb Units*, MRTS75 *Supply and Erection of Prestressed Concrete Girders* and MRTS76 *Supply and Erection of Steel Girders* and other requirements shown on the drawings and documentation.

9.11.8 Deck

The deck shall be set out in accordance with MRTS70 *Concrete*, MRTS77 *Bridge Deck* and MRTS84 *Deck Wearing Surface* and other requirements shown on the drawings and documentation.

9.11.9 Kerbs and parapets

Kerbs and parapets shall be set out in accordance with MRTS70 *Concrete* and MRTS77 *Bridge Deck* and other requirements shown on the drawings and documentation.

9.11.10 Relieving slabs

The relieving slabs shall be set out in accordance with MRTS70 *Concrete* and MRTS77 *Bridge Deck* and other requirements shown on the drawings and documentation.

10 Compliance / conformance testing

This clause refers only to mandatory compliance / conformance testing requirements specified in Transport and Main Roads Technical Specification documents.

10.1 Earthworks and subgrade treatments

All compliance testing activities to meet the geometric tolerance specifications for earthworks and subgrade treatments shall be in accordance with MRTS04 *General Earthworks* and MRTS07A *In situ Stabilised Subgrades using Quicklime or Hydrated Lime* and/or other requirements shown on the drawings and documentation. These activities typically include:

- stripping top soil
- subgrade treatments
- bottom of excavations
- bottom of excavations for culverts and/or end structures
- bottom of excavations for channels and drains
- earth fill material in subgrade
- earth fill material – other than in backfill, subgrade or verge, and
- verge.

10.2 Pavement layers

All compliance testing activities including geometric specifications for pavement layers shall be in accordance with MRTS05 *Unbound Pavements*, MRTS07B *In situ Stabilised Pavements using Cement or Cementitious Blends*, MRTS07C *In situ Stabilised Pavements using Foamed Bitumen*,

MRTS08 *Plant-Mixed Heavily Bound (Cemented) Pavements*, MRTS09 *Plant-Mixed Foamed Bitumen Stabilised Pavements*, MRTS10 *Plant-Mixed Lightly Bound Pavements*, MRTS30 *Asphalt Pavements* and MRTS32 *High Modulus Asphalt (EME2)*, MRTS39 *Lean Mix Concrete Sub-base for Pavements* and MRTS40 *Concrete Pavement Base* and/or other requirements shown on the drawings and documentation. These activities include the subbase, base and surface layers.

10.3 Kerb, channel and kerb and channel

All compliance testing activities including geometric specifications for kerbs, channels and kerb and channel shall be in accordance with MRTS03 *Drainage, Retaining Structures and Protective Treatments* and/or other requirements shown on the drawings and documentation.

10.4 Pavement drains

All compliance testing activities including geometric specifications for pavement drains shall be in accordance with MRTS38 *Pavement Drains* and/or other requirements shown on the drawings and documentation.

10.5 Noise fences

All conformance requirements for the constructed noise fence must meet the tolerance specifications as specified in MRTS15 *Noise Fences* and/or other requirements shown on the drawings and documentation.

10.6 Drainage

All compliance testing activities including geometric specifications for drainage shall be in accordance with MRTS03 *Drainage, Retaining Structures and Protective Treatments* and/or other requirements shown on the drawings and documentation. These activities include:

- culverts
- gullies
- inlet gullies
- access chambers
- subsoil drains, and
- vertical drains.

10.7 Conduits and pits

All conformance requirements for installed conduits must be met as specified in MRTS91 *Conduits and Pits* and/or as required in the construction drawings and documentation.

10.8 Retaining wall footings

All conformance requirements for the constructed elements must meet the tolerance specifications as specified in MRTS03 *Drainage, Retaining Structures and Protective Treatments* and/or as required in the construction drawings and documentation.

10.9 Bridges

All conformance requirements for the constructed elements must meet the tolerance specifications as specified in MRTS63 *Cast in Place Piles*, MRTS65 *Precast Prestressed Concrete Piles* or

MRTS66 *Driven Steel Piles*, MRTS70 *Concrete* and MRTS77 *Bridge Deck* and/or as required in the construction drawings and documentation.

10.9.1 Pile heave

The procedure for checking pile heave for driven piles shall be prepared by a Surveyor (as defined in Clause 5) and adopted in agreement with the Administrator. General procedure should be as follows:

1. Check existing or establish Bridge Construction Survey Control as defined in Clause 7.2.2.
2. Measuring equipment and methodologies must be capable of +/- 1 mm precision.
3. Measure and record final height to specific physical mark on the pile upon completion of pile driving and prior to driving adjacent pile in the same abutment or pier.
4. Re-check heights of Bridge Construction Survey Control.
5. Repeat procedure of points 3 and 4 for all piles in the same abutment or pier.
6. At the completion of all driven piles, re-measure heights of all piles in the same abutment or pier.
7. If differences between the first measurements and second measurements determine the heave to be greater than as specified in MRTS65 *Precast Prestressed Concrete Piles*, then the piles shall be subject to blow restrikes as specified in MRTS65 *Precast Prestressed Concrete Piles*.
8. Repeat points 3 to 7 if required and in agreement with the Administrators criteria for acceptance.
9. Final results / report (that includes measuring equipment details and calibration records) shall be certified by the Surveyor or RPEQ Engineer and submitted to the Administrator before any stripping of the pile head occurs.

10.10 Ancillary structure footings

All conformance requirements for the constructed elements must meet the tolerance specifications as specified in MRTS63A *Piles for Ancillary Structures* or as required in the construction drawings and documentation.

11 As Constructed Survey

As Constructed Survey are comprised of detailed Site survey measurements that provides an accurate geospatial record and validation compliance of completed Works. As Constructed survey information can be used to create a 3-dimensional (3D) digital representation (an object model with regards to location, size and shape) of the physical and functional characteristics of the infrastructure asset which is a key component of Building Information Modelling (BIM). 3D BIM will provide a logical structure of communication and control of accurate geospatial locational data which will also significantly benefit future design and asset management.

11.1 Survey at practical completion

As a condition precedent to the issue of the Certificate of Practical Completion, the Contractor must carry out and provide the Administrator with the As Constructed Survey deliverables of the Project

Works that details the actual location of the new infrastructure, including underground infrastructure and demonstrates that the Project Works are within the Site.

11.2 Earthworks

As Constructed Survey methodologies and accuracy requirements for earthworks are specified in Table 11.2. They also must be in accordance with associated drawings and contract documents.

Table 11.2 - As Constructed Survey – Earthworks (includes excavations, embankments, subgrade, channels and open drains)

Clause	As Constructed Survey	Methodology (Includes using appropriate codes as per the <i>TMR Surveying Standards – Schedule 1</i>)	Accuracy* Hz & Vt (mm)
11.2.1	Stripped area	Full extent of stripped area. 10 m x 10 m grid minimum. Include dips and mounds and changes in grade.	± 25
11.2.2	Bottom of excavation	All edges and interfaces. 10 m cross section minimum. Includes cut batters, crown, change in grade and at crests and dips in vertical curve geometry.	± 25
11.2.3	Bottom of excavated area of unsuitable material	All edges and interfaces. 10 m x 10 m grid minimum. And sufficient density of points to provide shape to interpolated average accuracy ± 25 mm Hz & Vt.	± 15
11.2.4	Bottom of excavated areas for end structures	Full extent of excavated area for end structures. And sufficient density of points to provide shape to interpolated average accuracy ± 25 mm Hz & Vt.	± 15
11.2.5	Top of embankment (including batters) prior to construction of the subgrade	10 m cross sections minimum. Including bottom of batters, the crown, longitudinal breaklines, change in grade and at crests and dips in vertical curve geometry.	± 25
11.2.6	Top of subgrade	10 m cross sections minimum. Includes crown, longitudinal breaklines, change in grade and at crests and dips in vertical curve geometry.	± 10
11.2.7	Bottom of excavations for channels and drains	Full width and at minimum 10 m intervals and changes in direction (both horizontal and vertical).	± 25

* Accuracies are stated in terms of 'relative uncertainty' at 95% confidence level.

11.2.1 Topsoil stripped area

After stripping of topsoil has been completed in accordance with MRTS04 *General Earthworks*, no further work over the stripped area shall be undertaken until the As Constructed Survey requirements have been met and notice of such Works provided to the Administrator. **Witness Point 4**

11.2.2 Bottom of excavation

After excavation has reached subgrade level in accordance with MRTS04 *General Earthworks*, no further work over the excavated area shall be undertaken until the As Constructed Survey requirements have been met and notice of such Works provided to the Administrator. **Witness Point 5**

11.2.3 Excavated area of unsuitable material

After excavation of unsuitable material has been completed in accordance with MRTS04 *General Earthworks*, no backfilling of the excavated area shall be undertaken until the As Constructed Survey requirements have been met and notice of such Works provided to the Administrator. **Witness Point 6**

After backfilling of the excavated area has been completed, an As Constructed Survey must be undertaken and notice of such Works provided to the Administrator. **Witness Point 7**

11.2.4 Bottom of excavated areas for end structures

After excavation for end structures has been completed in accordance with MRTS04 *General Earthworks*, no placement of precast concrete items shall be undertaken until the As Constructed Survey requirements have been met and notice of such Works provided to the Administrator.

Witness Point 8

11.2.5 Top of embankment (including batters) prior to construction of the subgrade

After completion of earthworks to subgrade level and proof rolling in accordance with MRTS04 *General Earthworks*, no construction of pavement Works shall be undertaken until the As Constructed Survey requirements have been met and notice of such Works provided to the Administrator. **Witness Point 9**

11.2.6 Top of subgrade

After completion of the subgrade in accordance with MRTS04 *General Earthworks*, MRTS07A *In situ Stabilised Subgrades Using Quicklime or Hydrated Lime*, MRTS07B *In situ Stabilised Pavements Using Cement or Cementitious Blends* and MRTS10 *Plant-Mixed Lightly Bound Pavements* no covering of a subsequent layer shall be undertaken until the As Constructed Survey requirements have been met and notice of such Works provided to the Administrator. **Witness Point 10**

11.2.7 Bottom of excavations for channels and drains

After completion of excavations for channels and drains have been completed, an As Constructed Survey shall be undertaken.

11.3 Pavements, pavement drains, kerb, channel and kerb and channel

As Constructed Survey methodologies and accuracy requirements for pavements (non-concrete), pavement drains, kerb, channel and kerb and channel are specified in Table 11.3. They also must be in accordance with associated drawings and contract documents.

Table 11.3(a) - As Constructed Survey – Pavement layers (non-concrete), pavement drains, kerb, channel and kerb and channel

Clause	As Constructed Survey	Methodology (Includes using appropriate codes as per the <i>TMR Surveying Standards – Schedule 1</i>)	Accuracy* Hz & Vt (mm)
11.3.1	Top of every pavement layer	10 m cross sections minimum that includes full width, crown*, longitudinal breaklines, change in grade, top** / toe edge of pavement layer and at crests and dips in vertical curve geometry. *Due to rounding of crown, capture 0.5 m either side of crown. ** Due to rounding of top edge, capture 0.5 m either side of top edge.	± 10

Clause	As Constructed Survey	Methodology (Includes using appropriate codes as per the <i>TMR Surveying Standards – Schedule 1</i>)	Accuracy* Hz & Vt (mm)
11.3.2	Kerb and channel top of kerb back, top, invert and lip	Must include the full shape of the kerb and channel. (Use design dimensions if required for bottom of kerb). Minimum at 10 m intervals, changes in grade, direction and over and under verticals at crests and dips in vertical curve geometry.	± 5
11.3.3	Footpath and Pram Crossings	Must include the full shape of the footpath and pram crossing. (Use design dimensions if required for bottom of footpath). Minimum at 10 m intervals, changes in grade, direction and over and under verticals at crests and dips in vertical curve geometry.	± 5
11.3.4	Pavement Drain	Full width and at minimum 10 m intervals and changes in direction (both horizontal and vertical).	± 10 Hz ± 5 Vt

* Accuracies are stated in terms of 'relative uncertainty' at 95% confidence level.

Table 11.3(b) - As Constructed Survey – Pavement layers (lean mix and concrete base)

Clause	As Constructed Survey	Methodology (Includes using appropriate codes as per the <i>TMR Surveying Standards – Schedule 1</i>)	Accuracy* Hz & Vt (mm)
11.3.5	Top Substrate	As per requirements under survey at the top of the substrate prescribed in MRTS39 <i>Lean Mix Concrete Sub-base for Pavements</i> .	± 10 Hz ± 3 Vt
	Top of Lean Mix Concrete Sub-base	As per requirements under survey at the top of the sub-base prescribed in MRTS39 <i>Lean Mix Concrete Sub-base for Pavements</i> .	± 10 Hz ± 3 Vt
11.3.6	Top of Base Invert Level	As per requirements for determining base invert level in MRTS40 <i>Concrete Pavement Base</i> .	± 10 Hz ± 3 Vt
	Top of Concrete Pavement Sub-base	As per requirements under Base level surveys prescribed in MRTS40 <i>Concrete Pavement Base</i> .	± 10 Hz ± 3 Vt
	Top of Concrete Base	As per requirements under Base level surveys prescribed in MRTS40 <i>Concrete Pavement Base</i> .	± 10 Hz ± 3 Vt

Using 3D laser scanning technology can be an acceptable methodology of undertaking an As Constructed Survey if all the requirements including accuracy can be achieved as prescribed in Table 11.3(a). Data extraction from the point cloud can then be applied to produce a 3D model.

In addition, to check the accuracy of the point cloud an alternative method of measuring cross sections using alternative measurement techniques shall be undertaken and data supplied. A minimum of three cross section checks is required at maximum 100 m intervals.

11.3.1 Top of every pavement layer (non-concrete)

After completion of each pavement layer in accordance with MRTS05 *Unbound Pavements*, MRTS07B *In situ Stabilised Pavements using Cement or Cementitious Blends*, MRTS07C *In situ Stabilised Pavements using Foamed Bitumen*, MRTS08 *Plant-Mixed Heavily Bound (Cemented) Pavements*, MRTS09 *Plant-Mixed Foamed Bitumen Stabilised Pavements*, MRTS10 *Plant-Mixed*

Lightly Bound Pavements, MRTS30 *Asphalt Pavements* and MRTS32 *High Modulus Asphalt (EME2)* no covering of a subsequent layer shall be undertaken until the As Constructed Survey requirements have been met and notice of such Works provided to the Administrator. **Witness Point 11**

The layer in this case is meant to mean the different layers that make up the road pavement; the subbase course, base course and surface (or wearing course), and not any individual compacted layers that may make up a course.

Figure 11.3.1 - Typical cross section of As Constructed Survey and conformance locations for pavement layers

Measurement locations should always be taken at the same chainage and offset dimensions to ensure accurate thickness results

- As Constructed Survey Pavement layer measurement locations
- As Constructed Survey and Conformance Pavement layer measurement locations
- Previous subgrade As Constructed Survey measurement locations
- Previous subgrade As Constructed Survey and Conformance measurement locations

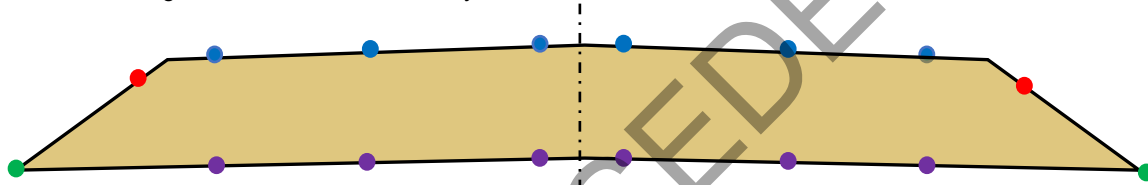

11.3.2 Kerb, channel and kerb and channel

An As Constructed Survey shall be undertaken after kerb, channel and kerb and channel Works has been completed in accordance with MRTS03 *Drainage, Retaining Structures and Protective Treatments*.

11.3.3 Footpaths and pram crossings

An As Constructed Survey shall be undertaken after footpath Works have been completed in accordance with hand-placed concrete paving in MRTS03 *Drainage, Retaining Structures and Protective Treatments*.

11.3.4 Pavement drains

An As Constructed Survey shall be undertaken after pavement drainage Works have been completed in accordance with MRTS38 *Pavement Drains*.

11.3.5 Lean mix concrete sub-base

Surveying requirements for the substrata for lean mix concrete sub-base and top of lean mix concrete sub-base are to be in accordance with MRTS39 *Lean Mix Concrete Sub-base for Pavements* and are specified in Table 11.3(b).

11.3.6 Concrete pavement base

Surveying requirements for the invert level of the subbase and top of the subbase and base of concrete pavements are to be in accordance with MRTS40 *Concrete Pavement Base* and are specified in Table 11.3(b).

For As Constructed Survey requirements for Lean Mix Concrete Sub-Base pavement and Concrete Pavement Base pavement, refer to MRTS39 *Lean Mix Concrete Subbase for Pavements* and MRTS40 *Concrete Pavement Base*.

Note: MRTS40 Appendix D.2.1. If a survey procedure is adopted which produces an as built level model of the top of both the subbase and base, each with comparison to the design model, this model may be accepted by the Administrator.

11.4 Road furniture

As Constructed Survey methodologies and accuracy requirements for road furniture are specified in Table 11.4. They also must be in accordance with associated drawings and contract documents.

Table 11.4 - As Constructed Survey – Road furniture

Clause	As Constructed Survey	Methodology (Includes using appropriate codes as per the <i>TMR Surveying Standards – Schedule 1</i>)	Accuracy* Hz & Vt (mm)
11.4.1	Concrete Road Safety Barrier	At minimum of 10 m intervals, change in direction and as per codes and examples of the <i>TMR Surveying Standards – Schedule 1</i> .	± 25
11.4.2	Guard Rail Posts	Top centre of posts	± 25
	Steel Beam Guardrail	As per codes and examples of the <i>TMR Surveying Standards – Schedule 1</i> .	± 25
11.4.3	Wire Rope Barrier	Top of wire at minimum 10 m intervals, change in direction and as per codes and examples of the <i>TMR Surveying Standards – Schedule 1</i> .	± 25
11.4.4	Road Signs / Project Signs	As per codes and examples of the <i>TMR Surveying Standards – Schedule 1</i> .	± 25
	Variable Message Signs	As per codes and examples of the <i>TMR Surveying Standards – Schedule 1</i> .	± 25
11.4.5	Fences	At minimum of 20 m intervals, change in direction and as per codes and examples of the <i>TMR Surveying Standards – Schedule 1</i> .	± 25
11.4.6	Gates	As per codes and examples of the <i>TMR Surveying Standards – Schedule 1</i> .	± 25
11.4.7	Field Cabinets	As per codes and examples of the <i>TMR Surveying Standards – Schedule 1</i> .	± 25
11.4.8	Road Light Poles	As per codes and examples of the <i>TMR Surveying Standards – Schedule 1</i> .	± 25
	Road Light Poles with Mast Arm	As per codes and examples of the <i>TMR Surveying Standards – Schedule 1</i> .	± 25
11.4.9	Traffic Signal Poles	As per codes and examples of the <i>TMR Surveying Standards – Schedule 1</i> .	± 25
	Traffic Signal Poles with Mast Arm	As per codes and examples of the <i>TMR Surveying Standards – Schedule 1</i> .	± 25
11.4.10	Electricity Poles	As per codes and examples of the <i>TMR Surveying Standards – Schedule 1</i> .	± 25
	Electricity Poles with Road Light Mast Arm	As per codes and examples of the <i>TMR Surveying Standards – Schedule 1</i> .	± 25

Clause	As Constructed Survey	Methodology (Includes using appropriate codes as per the <i>TMR Surveying Standards – Schedule 1</i>)	Accuracy* Hz & Vt (mm)
11.4.11	Overhead Wires	As per codes and examples of the <i>TMR Surveying Standards – Schedule 1</i> . Also record ambient air temperature and atmospheric description (for example, bright / sunny, partly cloudy / overcast) including estimated wind speed and direction.	± 50

* Accuracies are stated in terms of 'relative uncertainty' at 95% confidence level.

11.4.1 Concrete road safety barriers

An As Constructed Survey shall be undertaken after the concrete road safety barrier has been completed in accordance with MRTS14 *Road Furniture*.

11.4.2 Guard rails

An As Constructed Survey shall be undertaken after the guard rail barrier has been completed in accordance with MRTS14 *Road Furniture*.

11.4.3 Wire rope barrier

An As Constructed Survey shall be undertaken after the wire rope barrier has been completed in accordance with MRTS14 *Road Furniture*.

11.4.4 Road signs / Variable message signs

An As Constructed Survey shall be undertaken after road signs and variable message signs has been completed in accordance with MRTS14 *Road Furniture*.

11.4.5 Fences

An As Constructed Survey shall be undertaken after fence construction has been completed in accordance with MRTS14 *Road Furniture*.

11.4.6 Gates

An As Constructed Survey shall be undertaken after gate construction has been completed in accordance with MRTS14 *Road Furniture*.

11.4.7 Field cabinets

An As Constructed Survey shall be undertaken after the construction of field cabinets that can include telecommunication and electrical cabinets has been completed in accordance with MRTS14 *Road Furniture*.

11.4.8 Road light poles and road light poles with mast arms

An As Constructed Survey shall be undertaken after the construction of road light poles and road light poles with mast arms has been completed in accordance with MRTS94 *Road Lighting*.

11.4.9 Traffic signal poles and traffic signal poles with mast arms

An As Constructed Survey shall be undertaken after the construction of traffic signal poles and traffic signal poles with mast arms has been completed in accordance with MRTS93 *Traffic Signals*.

11.4.10 Electricity poles and electricity poles with road lighting mast arms

An As Constructed Survey shall be undertaken after the construction of electricity poles and electricity poles with road lighting mast arms has been completed in accordance with the requirements of the utility provider.

11.4.11 Overhead wires

Upon completion of overhead services (primarily electrical and aerial telecommunications), an As Constructed Survey shall be undertaken.

11.5 Drainage

The As Constructed Survey is for the specific purpose of recording the spatial location, size, shape and any other relevant attribute information for the constructed objects. There are no restrictions on how this can be done as long as the accuracy requirements in Table 11.5 are achieved. The recommended As Constructed Survey methodologies for drainage are specified in Table 11.5. They also must be in accordance with associated drawings and contract documents.

Table 11.5 - As Constructed Survey – Drainage

Clause	As Constructed Survey	Methodology (Includes using appropriate codes as per the <i>TMR Surveying Standards – Schedule 1</i>)	Accuracy* Hz & Vt (mm)
11.5.1	Drainage Systems and culverts under roadways	<p>For pipes, survey discrete points at the crown at each join. Measure internal diameter and pipe thickness of exposed pipes.</p> <p>For belled pipes, survey discrete points at the crown of the belled socket end. At exposed spigot ends, survey discrete points at the crown allowing or the height of the belled socket. Measure external dimension at exposed pipe at socket end. Measure internal dimension and pipe thickness. Measure taper and top of socket dimensions.</p> <p>For box culverts, survey discrete points at minimum 10 m intervals along top outside edge and top corners of base slab. Measure the height dimension of the base slab. Survey discrete points at the corner outside top edges for each cell. Measure the internal dimensions of the box culvert. For link slabs on multi-cell installations, survey discrete points at the corner outside top edges for each link slab. Measure the external height dimension of the link slab.</p> <p>Survey discrete points at exposed inverts for pipes, belled pipes and box culverts.</p>	± 10
	Culvert Roadway end Structures (head walls, wing walls & aprons)	As prescribed the <i>TMR Surveying Standards – Schedule 1</i> for culvert end structure	± 10
11.5.2	Concrete or Precast Concrete Side Inlet Gullies	<p>For the gully base, survey discrete points at the outside top edge corners. Measure the height dimension of the gully base.</p> <p>For the gully chamber, survey discrete points at the outside top edge corners. Measure the height dimension and wall thickness of the gully chamber.</p> <p>For the gully grate, survey discrete points at the corners.</p> <p>Survey the invert of the gully chamber.</p>	± 10

Clause	As Constructed Survey	Methodology (Includes using appropriate codes as per the <i>TMR Surveying Standards – Schedule 1</i>)	Accuracy* Hz & Vt (mm)
11.5.3	Precast Concrete or Insitu Concrete Access Circular Chambers	<p>For chamber base nib, survey discrete points equally spaced on the top external outline of the chamber base nib. Measure height of chamber base nib.</p> <p>For the chamber, survey minimum of four discrete points equally spaced on the top external outline of the chamber. Measure the wall thickness and height of shaft and base.</p> <p>For reducers, survey minimum of four discrete points equally spaced on the top external outline of the reducer. Measure the wall thickness of the reducer. Measure the collar heights at the top and bottom of the reducer.</p> <p>For the surround, survey minimum of four discrete points equally spaced on the top external outline of the surround. Measure height of surround.</p> <p>For the lid, survey minimum of four discrete points equally spaced on the top external outline of the lid. Measure height of lid.</p> <p>Survey invert of the chamber.</p>	± 10
	Precast Concrete or Insitu Concrete Access Multi-sided Chambers	<p>For chamber base, survey discrete points at the corner outside top edges of the chamber base. Measure height of chamber base.</p> <p>For the chamber, survey discrete points at the corner outside top edges of the chamber. Measure the wall thickness and height of chamber.</p> <p>For the surround, survey discrete points at the corner outside top edges of the surround. Measure height of surround.</p> <p>For the circular lid, survey minimum of four discrete points equally spaced on the top external outline of the lid. Measure height of lid.</p> <p>Survey invert of the chamber.</p>	
11.5.4	Subsoil Drains	Subsoil drains shall be surveyed at intervals not exceeding 5 m and including every change in (horizontal and direction vertical).	± 10
11.5.5	Vertical Drains	Vertical drains shall be surveyed at intervals not exceeding 5 m and including every change in (horizontal and direction vertical).	± 10

* Accuracies are stated in terms of 'relative uncertainty' at 95% confidence level.

11.5.1 Drainage systems and culverts

After installation of drainage systems and culvert Works have been completed in accordance with MRTS03 *Drainage, Retaining Structures and Protective Treatments*, backfilling shall not be undertaken until the As Constructed Survey requirements have been met and notice of such Works (excludes delivery of As Constructed Survey information) provided to the Administrator. **Hold Point 9**

11.5.2 Gullies

After installation of concrete gullies or precast concrete side inlet gullies have been completed in accordance with MRTS03 *Drainage, Retaining Structures and Protective Treatments*, placement of grates shall not be undertaken until the As Constructed Survey requirements have been met and

notice of such Works (excludes delivery of As Constructed Survey information) provided to the Administrator. **Hold Point 10**

Figure 11.5.2 is an example of suggested capture methodology, coding and dimensional attribute information required that may be adopted for As Constructed Survey of gullies.

Figure 11.5.2 - As Constructed Survey of gullies

Gully pit and Field inlet			
Element	Code	Capture method description	Regular shape
GULLY BASE	PILP	Lowest point on inside bottom of chamber	
	OD_	Outside top outline of gully base	1 - 4
GULLY	OD_	Outside top outline of gully pit	5 - 8
GRATE	OD_	Outside top outline of grate	9 - 12

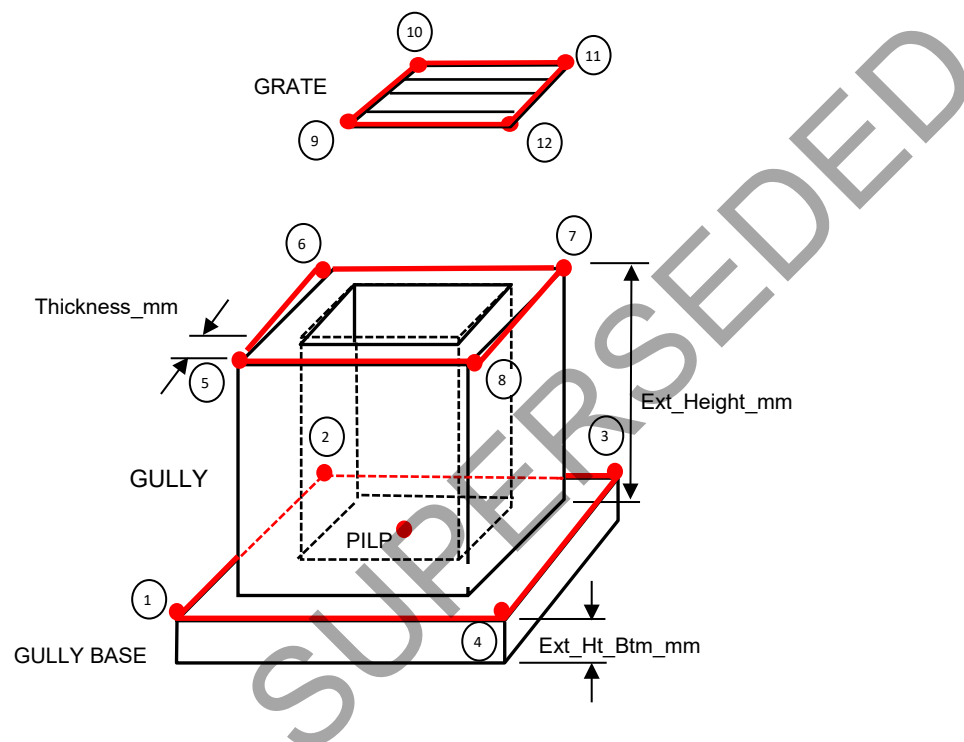

11.5.3 Access chambers

After installation of precast concrete or insitu concrete access chambers have been completed in accordance with MRTS03 *Drainage, Retaining Structures and Protective Treatments*, placement of concrete top slabs shall not be undertaken until the As Constructed Survey requirements have been met and notice of such Works (excludes delivery of As Constructed Survey information) provided to the Administrator. **Hold Point 11**

Figures 11.5.3(a) and 11.5.3(b) are examples of suggested capture methodology, coding and dimensional attribute information required that may be adopted for As Constructed Survey of access chambers.

Figure 11.5.3(a) - As Constructed Survey of circular access chamber

Stormwater Access Chamber		
Element	Code	Capture method description
CIRC BASE NIB	PILP	Lowest point on inside bottom of chamber.
	OD_	Capture top external circumference by using 4 points equally spaced. Example: CIRC BASE NIB Points 1 – 4. NOTE: If it is not possible to measure the CIRC BASE NIB, provide the supplier (precast) or design drawing (in-situ) dimensions and suffixed with a *
SHAFT & BASE	OD_	Capture external circumference by using 4 points equally spaced. Example: SHAFT & BASE Points 5 – 8.
REDUCER	OD_	Generally, there are two different types. a non-concentric tapered cone that provides a vertical wall and a concentric tapered cone. Capture methodology is the same. Capture external circumference at the top of the REDUCER Points 9 – 12. Measure external dimensions.
CIRC SURROUND	OD_	Capture top external circumference of the surround by using 4 points equally spaced. Example: CIRC SURROUND Points 13 – 16.
CIRC LID	OD_	Capture top external circumference by using 4 points equally spaced. Points 17 – 20.

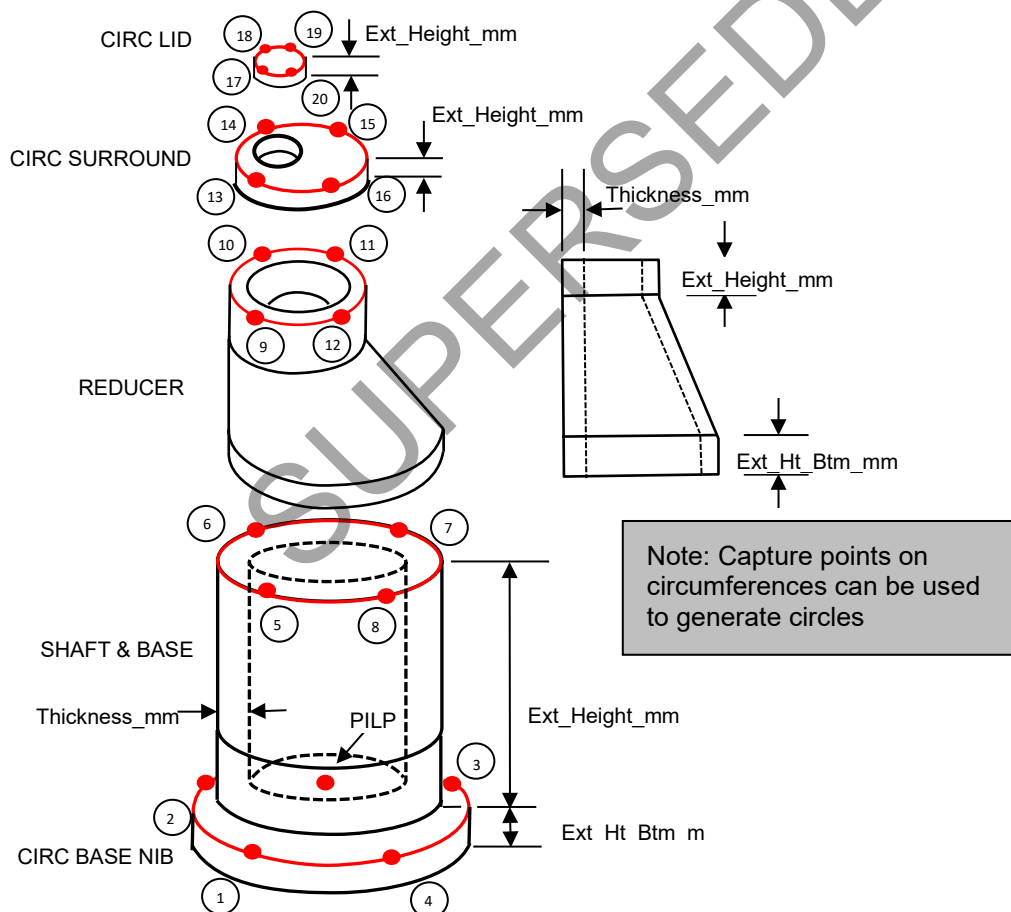
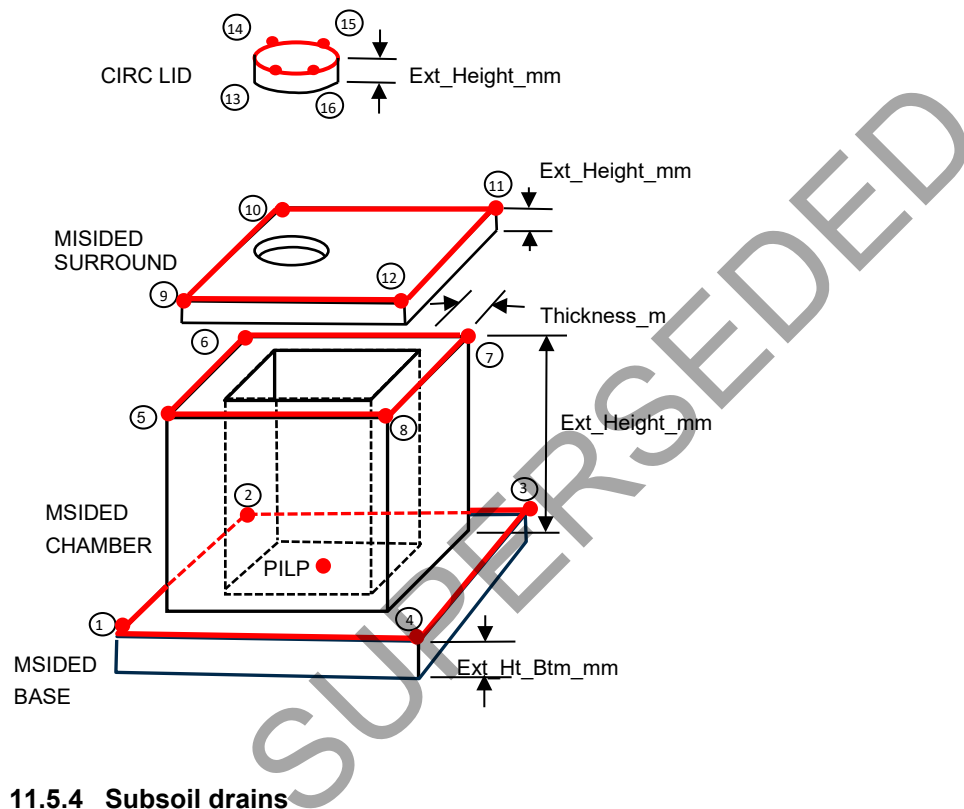

Figure 11.5.3(b) - As Constructed Survey of multi sided access chamber

Stormwater Access Chamber			
Element	Code	Capture method description	
MSIDED BASE	OD_	Outside top outline of base. NOTE: If it is not possible to measure the base, use the supplier (precast) or design drawing (in-situ) dimensions and suffixed with a *	1 - 4
MISIDED CHAMBER	PILP	Lowest point on inside bottom of chamber.	
	OD_	Outside top outline of chamber.	5 - 8
MISIDED SURROUND	OD_	Outside top outline of surround.	9 - 12
CIRC LID	OD_	Capture top external circumference by using four points equally spaced.	13 - 16



11.5.4 Subsoil drains

After installation of subsoil drains have been completed in accordance with MRTS03 *Drainage, Retaining Structures and Protective Treatments*, backfilling of the trench shall not be undertaken until the As Constructed Survey requirements have been met and notice of such Works provided to the Administrator. **Witness Point 12**

11.5.5 Vertical drains

After installation of vertical drains have been completed in accordance with MRTS03 *Drainage, Retaining Structures and Protective Treatments*, subsequent construction of pavement layers shall not be undertaken until the As Constructed Survey requirements have been met and notice of such Works provided to the Administrator. **Witness Point 13**

11.5.6 Attribute information

Attribute information on the located assets shall include:

- asset owner
- asset type
- date of installation
- date of capture
- asset material
- size
- location, for example, top / crown, and
- status: for example 'constructed'.

11.6 Subsurface footings

Recommended As Constructed Survey methodologies for subsurface footings are specified in Table 11.6. Accuracy requirements are specified in Table 11.6. They also must be in accordance with associated drawings and contract documents.

Table 11.6 - As Constructed Survey – Subsurface footings

Clause	As Constructed Survey	Methodology (Includes using appropriate codes as per the TMR Surveying Standards – Schedule 1)	Accuracy* Hz & Vt (mm)
11.6.1	Concrete Retaining Wall Pad / Strip Footing	Survey discrete points at the bottom corners and bottom edges at minimum 2.5 m intervals of the excavated area prior to concrete pour. Survey discrete points at the top corners and top edges at minimum 2.5 m intervals of the concrete footing prior to backfilling. Survey discrete points along the bottom concrete wall edges at minimum 2.5 m intervals prior to backfilling.	± 5 Hz ± 10 Vt
11.6.2	Ancillary Structure Pile Footing	Survey the centre and invert location of the footing excavation. After installation, survey the top perimeter of the footing.	± 10
	Ancillary Structure Pile Footing Cap	All top edges including corners at minimum 2.5 m intervals.	± 10
11.6.3	Noise Fence Pile / Spread Footings Excavation	Survey the centre and invert location of the footing or extent of spread footing excavation. After installation, survey the top perimeter of the footing.	± 10
	Constructed Noise Fence Pile / Spread Footings	For piles, survey the centre and invert location of the footing excavation. For spread footings, survey the top corners and top edges at minimum 2.5 m intervals of the excavated area. After installation, survey the top perimeter of the footing prior to backfill.	± 10
11.6.4	Traffic and Road Lighting Footings	Survey the centre and invert location of the excavation. After installation, survey the top perimeter of the footing.	± 10
11.6.5	Load Bearing Footings	Full extent of excavated area for load bearing footings. After installation, survey the top perimeter of the footing	± 10

Clause	As Constructed Survey	Methodology (Includes using appropriate codes as per the <i>TMR Surveying Standards – Schedule 1</i>)	Accuracy* Hz & Vt (mm)
11.6.6	Concrete Masonry Wall Footings	Survey the corners and edges at minimum 2.5 m intervals of the footing.	± 10
	Crib Wall Footings		

* Accuracies are stated in terms of 'relative uncertainty' at 95% confidence level.

11.6.1 Retaining wall pad / strip footings

After excavation and formwork of the retaining wall footings have been completed in accordance with MRTS03 *Drainage, Retaining Structures and Protective Treatments*, the concrete pour shall not be undertaken until an As Constructed Survey of the excavated area has been met and notice of such Works provided to the Administrator. **Witness Point 14**

Figure 11.6.1(a) - As Constructed Survey of excavated area of retaining wall footing

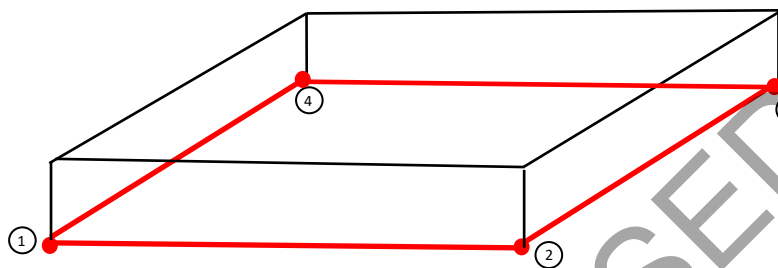

Typical retaining wall footing excavated area

After concrete pour of the retaining wall footings have been completed in accordance with MRTS03 *Drainage, Retaining Structures and Protective Treatments*, backfilling shall not be undertaken until the As Constructed Survey requirements have been met and notice of such Works provided to the Administrator. **Witness Point 15**

Figure 11.6.1(b) - As Constructed Survey of retaining wall footing

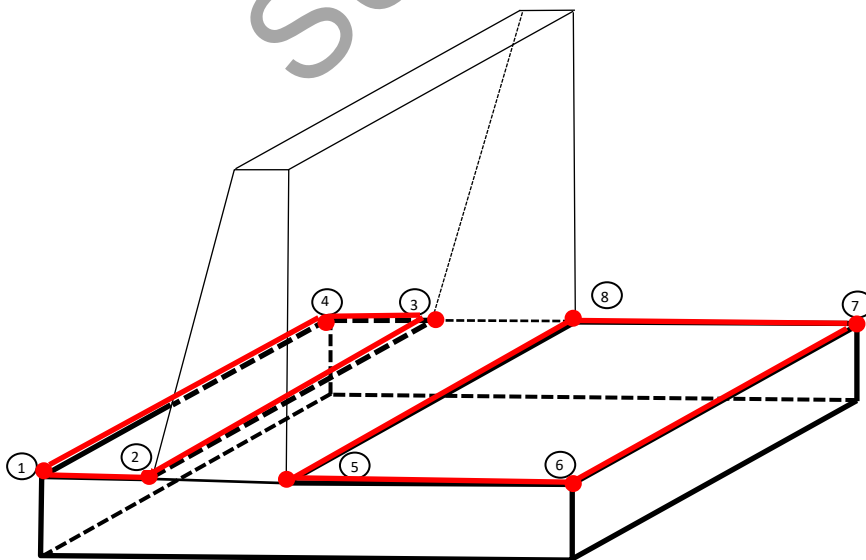

Typical retaining wall

11.6.2 Ancillary structure pile footings

After construction Works of ancillary structure for pile caps such as sign gantries, retaining walls, light poles, masts, hoardings and advertising signs have been completed in accordance with MRTS63A *Piles for Ancillary Structures*, an As Constructed Survey shall be undertaken.

11.6.3 Noise fence pile / spread footings

After excavation of pile / spread footings have be completed in accordance with MRTS15 *Noise Fences*, placement of the posts shall not be undertaken until the As Constructed Survey requirements have been met and notice of such Works provided to the Administrator. **Witness Point 16**

After construction noise fence pile / spread footings have been completed in accordance with MRTS15 *Noise Fences*, no further work shall not be undertaken until the As Constructed Survey requirements have been met and notice of such Works provided to the Administrator.

Witness Point 17

11.6.4 ITS Technologies– Traffic signal and road lighting footings

After excavation of a footing has been completed in accordance with MRTS92 *Traffic Signal and Road Lighting Footings*, placement of the anchor cage shall not be undertaken until the As Constructed Survey requirements have been met and notice of such Works provided to the Administrator.

Witness Point 18

After construction Works of the footing has been completed in accordance with MRTS92 *Traffic Signal and Road Lighting Footings*, an As Constructed Survey shall be undertaken.

11.6.5 Load bearing footings

After excavation of load bearing footings have been completed in accordance with MRTS04 *General Earthworks*, covering of the foundation surface shall not be undertaken until the As Constructed Survey requirements have been met and notice of such Works provided to the Administrator.

Witness Point 19

After construction of the load bearing footings have been completed in accordance with associated drawings and documentation, an As Constructed Survey shall be undertaken.

11.6.6 Concrete masonry / Crib wall footings

After construction of concrete masonry / crib wall footings have been completed in accordance with MRTS03 *Drainage, Retaining Structures and Protective Treatments*, no further work shall be undertaken until the As Constructed Survey requirements have been met and notice of such Works provided to the Administrator. **Witness Point 20**

11.7 Traffic Engineering Technology and Systems (TETS)– Conduits and pits

As Constructed Survey methodologies and accuracy requirements for conduits and pits are specified in Table 11.7. They also must be in accordance with associated drawings and contract documents.

After construction Works of the Traffic Engineering Technology and Systems (TETS) conduits and pits have been completed in accordance with MRTS91 *Conduits and Pits*, backfilling of trenches shall not be undertaken until the Conformance and As Constructed Survey requirements have been met and notice of such Works (excludes delivery of As Constructed Survey information) provided to the Administrator. **Hold Point 12**

Table 11.7 - As Constructed Survey – Conduits and pits (TETS)

Clause	As Constructed Survey	Methodology (Includes using appropriate codes as per the <i>TMR Surveying Standards – Schedule 1</i>)	Accuracy Hz & Vt (mm)
11.7	Exposed conduits	Conduits shall be surveyed at intervals not exceeding 5 m and including every change in (horizontal and direction vertical). For curves, enough intervals are required to show a reasonably shaped curve, so that the arc to chord distance is no greater than 50 mm.	± 25
	Exposed nested conduits	Survey at intervals not exceeding 5 m and including every change in direction (horizontal and vertical) along top centre of nested conduits. Measure external width and height of nested conduits at each capture location. Record number of conduits within the nest.	
	Borehole conduits	Survey the marked locations and depths on the ground surface from the sonde at intervals determined by the length of the drill rod and at minimum 10 m intervals.	± 50
	Pits	Survey dimensions that represent size, shape and location.	± 25

11.7.1 Attribute information

Attribute information on the located assets shall include:

- asset owner
- asset type
- date of installation
- date of capture
- asset material
- size
- location, for example, top / crown of conduit, and
- status: for example 'constructed'.

11.8 Retaining walls (above ground)

As Constructed Survey methodologies and accuracy requirements for above ground retaining wall are specified in Table 11.8. They also must be in accordance with associated drawings and contract documents.

Table 11.8 - As Constructed Survey – Retaining walls (above ground)

Clause	As Constructed Survey	Methodology (Includes using appropriate codes as per the <i>TMR Surveying Standards – Schedule 1</i>)	Accuracy* Hz & Vt (mm)
11.8.1	Concrete Retaining Wall	As per codes and examples of the <i>TMR Surveying Standards – Schedule 1</i> .	± 10

Clause	As Constructed Survey	Methodology (Includes using appropriate codes as per the <i>TMR Surveying Standards – Schedule 1</i>)	Accuracy* Hz & Vt (mm)
11.8.2	Crib Retaining Wall	As per codes and examples of the <i>TMR Surveying Standards – Schedule 1</i> .	± 10
11.8.3	Boulder Retaining Wall	As per codes and examples of the <i>TMR Surveying Standards – Schedule 1</i> .	± 10
11.8.4	Reinforced Soil Structure Retaining Wall	As per codes and examples of the <i>TMR Surveying Standards – Schedule 1</i> .	± 10
11.8.5	Soil Nail	Centre of installed soil nail.	± 10
11.8.6	Active Rock Bolts	Centre of installed active rock bolt.	± 10
11.8.7	Passive Rock Dowels	Centre of installed passive rock dowel.	± 10

* Accuracies are stated in terms of 'relative uncertainty' at 95% confidence level.

11.8.1 Concrete retaining walls

After construction of the concrete retaining wall has been completed in accordance with MRTS03 *Drainage, Retaining Structures and Protective Treatments*, or associated drawings and documentation, an As Constructed Survey shall be undertaken.

11.8.2 Crib retaining walls

After construction of the crib retaining wall has been completed in accordance with MRTS03 *Drainage, Retaining Structures and Protective Treatments*, or associated drawings and documentation, an As Constructed Survey shall be undertaken.

11.8.3 Boulder retaining wall

After construction of the boulder retaining wall has been completed in accordance with MRTS03 *Drainage, Retaining Structures and Protective Treatments*, or associated drawings and documentation, an As Constructed Survey shall be undertaken.

11.8.4 Reinforced soil structure retaining walls

After construction of the boulder retaining wall has been completed in accordance with MRTS06 *Reinforced Retaining Structures*, or associated drawings and documentation, an As Constructed Survey shall be undertaken.

11.8.5 Soil nails

After the installation of the soil nails have been completed in accordance with MRTS03 *Drainage, Retaining Structures and Protective Treatments*, or associated drawings and documentation, an As Constructed Survey shall be undertaken.

11.8.6 Active rock bolt

After installation of active rock bolts have been completed in accordance with MRTS03 *Drainage, Retaining Structures and Protective Treatments*, or associated drawings and documentation, an As Constructed Survey shall be undertaken.

11.8.7 Passive rock dowels

After installation of passive rock dowels have been completed in accordance with MRTS03 *Drainage, Retaining Structures and Protective Treatments*, or associated drawings and documentation, an As Constructed Survey shall be undertaken.

11.9 Noise fences

As Constructed Survey methodologies and accuracy requirements for noise fences are specified in Table 11.9.

An As Constructed Survey shall be undertaken after the noise fence has been completed in accordance with MRTS15 *Noise Fences* and associated drawings and contract documents.

Table 11.9 - As Constructed Survey – Noise fences

Clause	As Constructed Survey	Methodology (Includes using appropriate codes as per the <i>TMR Surveying Standards – Schedule 1</i>)	Accuracy* Hz & Vt (mm)
11.9	Noise Fences	As per codes and examples of the <i>TMR Surveying Standards – Schedule 1</i> .	± 10

* Accuracies are stated in terms of 'relative uncertainty' at 95% confidence level.

11.10 Horizontal directional drilling, microtunnelling and thrust boring and auger boring

As Constructed Survey methodologies and accuracy requirements for horizontal directional drilling, microtunnelling and thrust boring and auger boring are specified in Table 11.10. They also must be in accordance with associated drawings and contract documents.

Table 11.10 - As Constructed Survey – Horizontal directional drilling, Microtunnelling and Thrust boring and auger boring

Clause	As Constructed Survey	Methodology (Includes using appropriate codes as per the <i>TMR Surveying Standards – Schedule 1</i>)	Accuracy* Hz & Vt (mm)
11.10.1	Horizontal Directional Drilling	Survey the marked locations and depths on the ground surface from the sonde at intervals determined by the length of the drill rod and at minimum 10 m intervals.	± 50
11.10.2	Microtunnelling and Jacking		
11.10.3	Thrust / Auger boring		

* Accuracies are stated in terms of 'relative uncertainty' at 95% confidence level.

11.10.1 Horizontal directional drilling

After horizontal directional drilling Works are completed in accordance with MRTS140 *Horizontal Directional Drilling (HDD)* an As Constructed Survey is to be undertaken as specified in Table 11.10.

11.10.2 Microtunnelling and pipe jacking

After microtunnelling and pipe jacking Works are completed in accordance with MRTS141 *Microtunnelling and Pipe Jacking* an As Constructed Survey is to be undertaken as specified in Table 11.10.

11.10.3 Thrust boring and auger boring

After thrust boring and auger boring Works are completed in accordance with MRTS142 *Thrust Boring and Auger Boring* an As Constructed Survey is to be undertaken as specified in Table 11.10.

The sonde at the bottom of the hole assembly (BHA) transmits a signal showing location, depth and direction and the all important angle of the drill head. A second person uses a receiver above ground to follow the sonde and track it for the operator.

11.11 3rd Party underground assets – including Public Utility Plant (PUP)

Where the relevant utility provider is required to adjust, modify, relocate, enhance or provide utility infrastructure and after construction Works have been completed to the relevant utility providers specification and meeting TN163 *Third Party Utility Infrastructure Installation in State-Controlled Roads Technical Guideline* requirements, an As Constructed Survey must be undertaken as prescribed in Table 11.11 prior to backfilling of trenches and notice of such Works (excludes delivery of As Constructed Survey information) provided to the Administrator. **Hold Point 13**

Table 11.11 - As Constructed Survey – Underground assets (3rd party)

Clause	As Constructed Survey	Methodology (Includes using appropriate codes as per the <i>TMR Surveying Standards – Schedule 1</i>)	Accuracy* Hz & Vt (mm)
11.11	<ul style="list-style-type: none"> • Electricity Conduits • Electricity Inspection Chambers and Pits • Fuel Lines • Fuel Inspection Chambers • Gas Lines • Gas Valves • Gas Inspection Chambers and Pits • Thrust Blocks • Oil Lines • Sewer Lines • Sewer Valves • Sewer Chambers and Pits • Telecommunication conduits, direct buried fibre or cable and pits • Water Main Lines • Water Main Hydrants, Valves and Meters • Water Main Inspection Chambers and Pits, and • Envelopers 	<p>As prescribed in Underground Assets in the <i>TMR Surveying Standards, Part 2</i>.</p> <p>Check for meeting all conformance requirements for installed conduits and clash avoidance with subsequent construction of other assets.</p>	± 25

* Accuracies are stated in terms of 'relative uncertainty' at 95% confidence level.

11.12 Bridges

As Constructed Survey methodologies and accuracy requirements for bridges are specified in Table 11.12. They also must be in accordance with associated drawings and contract documents.

Table 11.12 - As Constructed Survey - Bridges

Clause	As Constructed Survey	Methodology	Accuracy* Hz (mm)	Accuracy* Vt (mm)
11.12.1	Piles	Perimeter at top of pile and at least one further perimeter below top of pile at sufficient length to determine verticality / rake of pile. Measure marked 1 m section/s on pile (if marked on piles) and top of pile after final cut-off work completed.	± 10	± 10
11.12.2	Pile Caps	All top edges including corners at minimum 2.5 m intervals.	± 10	± 5
11.12.3	Abutments, Columns and Headstocks	All top and bottom edges including corners at minimum 2.5 m intervals.	± 3	± 3
11.12.4	Coreholes	Centre of corehole.	± 3	-
11.12.5	Pedestals / Plinths	Minimum location points at top corners. Use calibrated level and staff for height on corners of pedestal / plinth.	± 5	± 1
11.12.6	Deck Units / Girders	At minimum, all top edges at minimum 2.5 m intervals along girder / headstock.	± 10	± 3
11.12.7	Deck	All top edges and across deck surface at minimum 2.5 m intervals.	± 10	± 3
11.12.8	Kerbs, Parapets and Relieving Slabs	Along top edges at minimum 2.5 m intervals.	± 5	± 5

* Accuracies are stated in terms of 'relative uncertainty' at 95% confidence level.

Note: If 3D laser scanning techniques have been used to undertake an As Constructed Survey of the constructed objects throughout the construction process then conformance reporting results to produce heat mapping techniques using surveying and design software may be used as an additional visual tool to compare between the As Constructed Survey surface and the design surface or creating isopach maps (contours) of the thickness between two surfaces.

11.12.1 Piles

After pile Works have been completed in accordance with MRTS63 *Cast in Place Piles*, MRTS64 *Driven Tubular Steel Piles (with reinforced concrete pile shaft)*, MRTS65 *Precast Prestressed Concrete Piles* or MRTS66 *Driven Steel Piles* or associated drawings and documentation, an As Constructed Survey shall be undertaken

Measure the location, vertical direction and shape of piles by direct angular and distance measurement or other accepted suitable methodology (for example, a Total Station or Robotic Total Station) or by scanning the surface of the pile as in Figure 11.12.1(a) and (b). Full shape and location of the entire pile can be extrapolated in its direction from the measured data and known lengths of the piles prior to boring or pile driving.

If direct measurement to a circular vertical pile by a Total Station or Robotic Total Station is used a minimum of six points should be measured around the perimeter to determine the centroid of the pile at cut off height.

Figure 11.12.1 – As Constructed Survey of piles

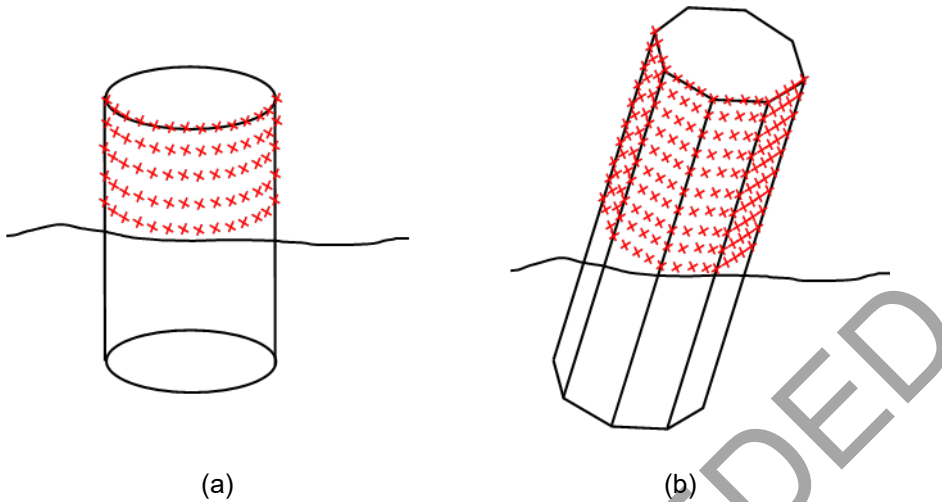

11.12.2 Pile caps

After pile caps Works have been completed in accordance with MRTS70 *Concrete* or associated drawings and documentation, an As Constructed Survey shall be undertaken by measuring location, and shape of pile caps by direct measurement or by scanning techniques. See Figure 11.12.2(a).

Figure 11.12.2(a) - As Constructed Survey of pile caps

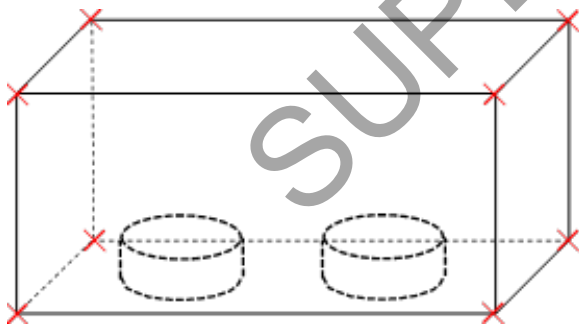

Note: For compliance testing measurement the resulting virtual edge derived from the intersection of the adjacent projected chamfered faces is required. This can be achieved by using a reflector fixed to a builder's square (see Figure 11.12.2(b)) or measuring the offset distance from the chamfered edge or constructing the edge from the measured adjacent faces (see Figure 11.12.2(c)).

For As Constructed Survey purposes, the virtual edge (Figure 11.12.2(c)) or the chamfered edges (Figure 11.12.2(d)) on the concrete elements can be used to create an As Constructed Survey Model.

Figure 11.12.2(b), (c), (d) - As Constructed Survey of chamfered edges

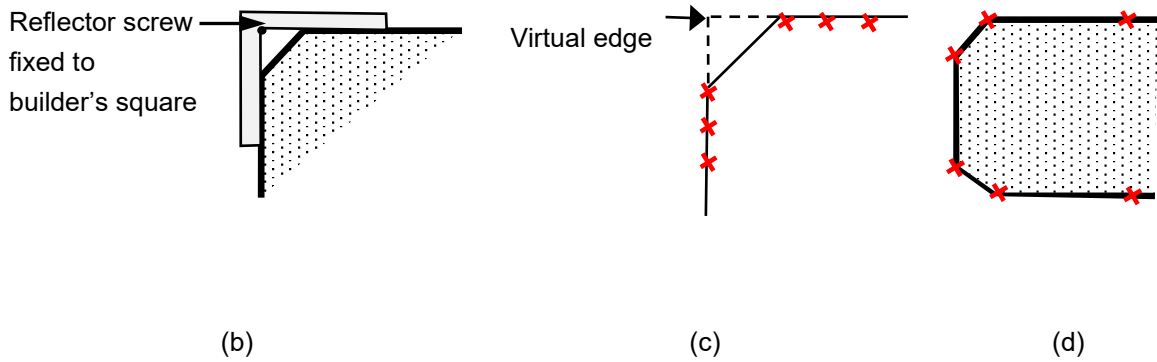

11.12.3 Columns, abutments and headstocks

After columns, abutments and headstock Works have been completed in accordance with MRTS62 *Bridge Substructure* and MRTS70 *Concrete* or associated drawings and documentation, an As Constructed Survey shall be undertaken by measuring location, and shape of abutments, columns and headstocks by direct measurement or by scanning techniques. See Figure 11.12.3.

Figure 11.12.3 - As Constructed Survey of columns, abutments and headstocks

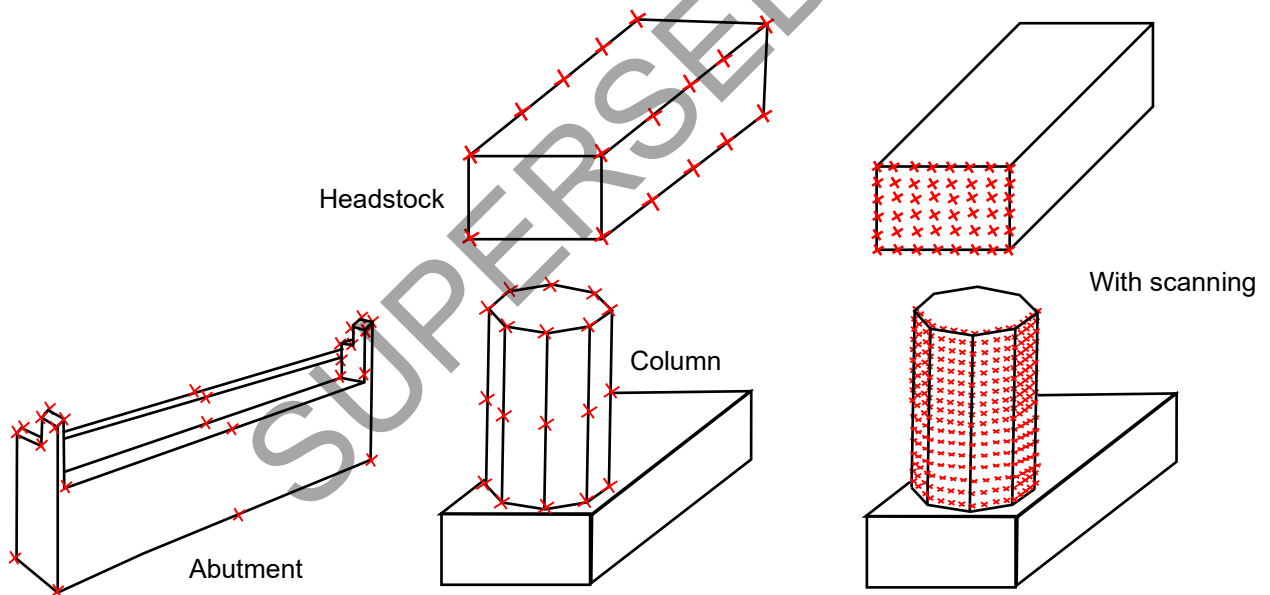

11.12.4 Coreholes

An As Constructed Survey shall be undertaken by measuring the centre locations of abutments / headstock coreholes. See Figure 11.12.4.

Figure 11.12.4 - As Constructed Survey of coreholes

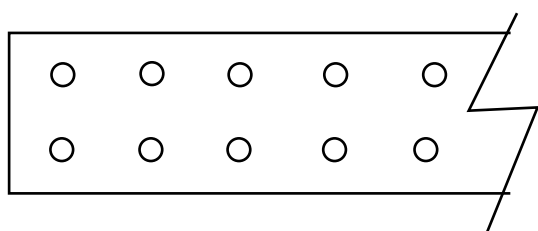

11.12.5 Bearing pedestal / plinth

An As Constructed Survey shall be undertaken by measuring the location and shape of the bearing pedestal / plinth.

Height of the pedestal / plinth corners should be measured with a calibrated level and staff or alternative surveying equipment and methodologies that can meet the accuracy requirements.

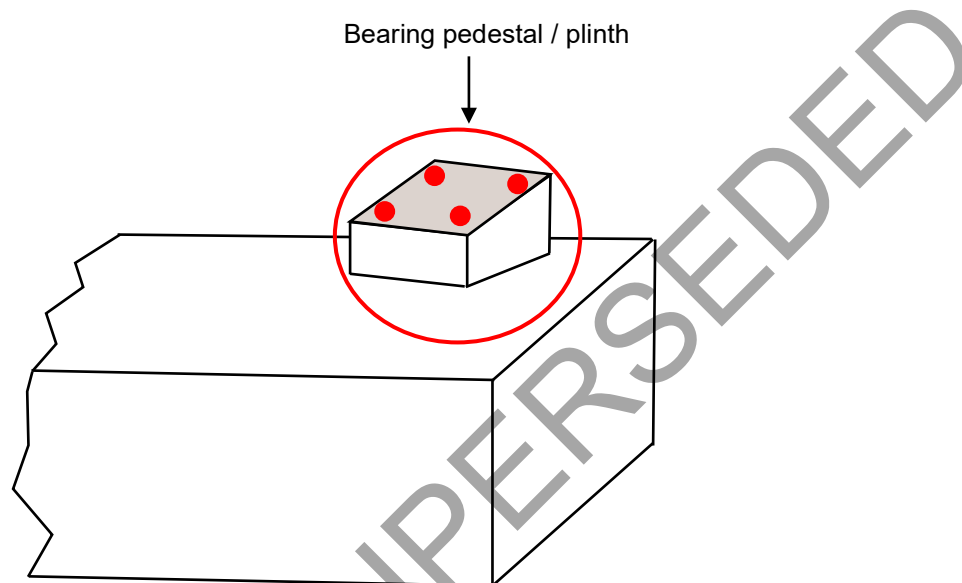

11.12.6 Girders / deck units

After girders / deck units have been placed in accordance with MRTS70 *Concrete* and MRTS73 *Manufacture of Prestressed Concrete Members and Stressing Units* or associated drawings and documentation, an As Constructed Survey shall be undertaken by measuring location, and shape of the girders / deck units by direct measurement or by scanning techniques. See Figure 11.12.6. The minimum measurement locations should be at the end of units, $\frac{1}{4}$ span, mid-span and $\frac{3}{4}$ span.

When a deck is poured onto deck units / girders the mass of the concrete deck will cause the hog in the beams to reduce.

This is known as pre-camber. Its effect can be measured directly on the underside of the deck units / girders during three separate phases:

- deck unit / girder placement
- insitu construction of the deck, and
- construction of the Deck Wearing Surface (DWS).

Once the deck units / girders have been placed, additional measurement points along the edges / face along the deck unit / girder will provide an accurate reference line / face to measure the pre-camber effect once the deck slabs have been poured and the final Deck Wearing Surface (DWS) has been placed. This can be done by conventional Total Station and prism, however, the scanning functionality of the Total Station would be far more practical. If possible, carry out measurements on the underside of deck units / girders. It is preferable to use the underside measurements of the deck units / girders as a reference line / surface during each phase. Temperature variation between the top and bottom side of the girder / deck unit can cause a measurable flexing effect. For this reason, camber measurements should be taken at the same times of day, preferably early morning when the effect of temperature variation is at its lowest. This procedure should eliminate or minimise the temperature variation effect between the top and bottom sides of the girders / deck units.

Figure 11.12.6 - As Constructed Survey of deck units / girders

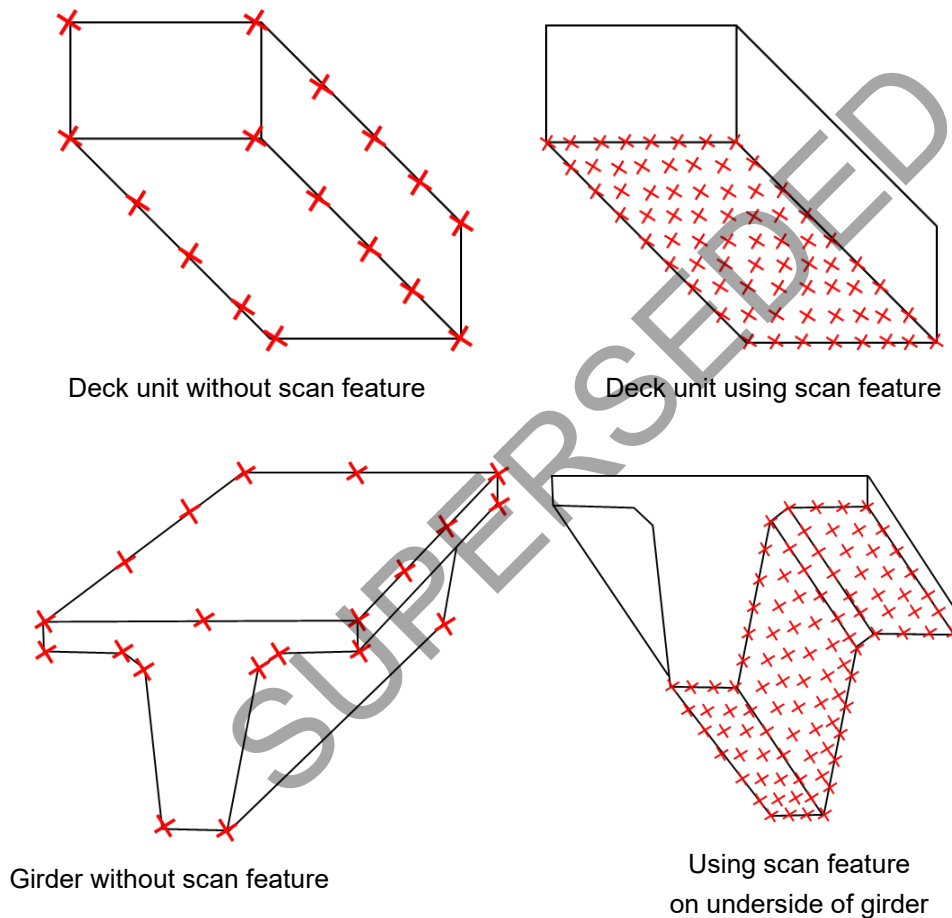

11.12.7 Deck

After deck Works have been completed in accordance with MRTS70 *Concrete* and MRTS77 *Bridge Deck* or associated drawings and documentation, an As Constructed Survey shall be undertaken on the top of the concrete deck slab, including expansion joints, and again on the top of the Deck Wearing Surface (DWS). Measurements should be in similar locations as measured on the girders / deck units.

If possible, carry out measurements in the same locations on the underside of girders / deck units once the concrete deck slab has been constructed. These camber measurements should be taken at

the same times of day as the previous measurements prior to the deck pour. This should ensure that any height differences due to temperature variation movement on the underside of the girder / deck unit should be very minimal.

If possible, carry out same measurements on the underside of girders / deck units once the Deck Wearing Surface (DWS) has been laid.

Note: These final measurements can be used to produce a 3D electronic As Constructed Model elements for the deck units / girders.

Figure 11.12.7(a) - As Constructed Survey of deck surface and underside of deck units / girders

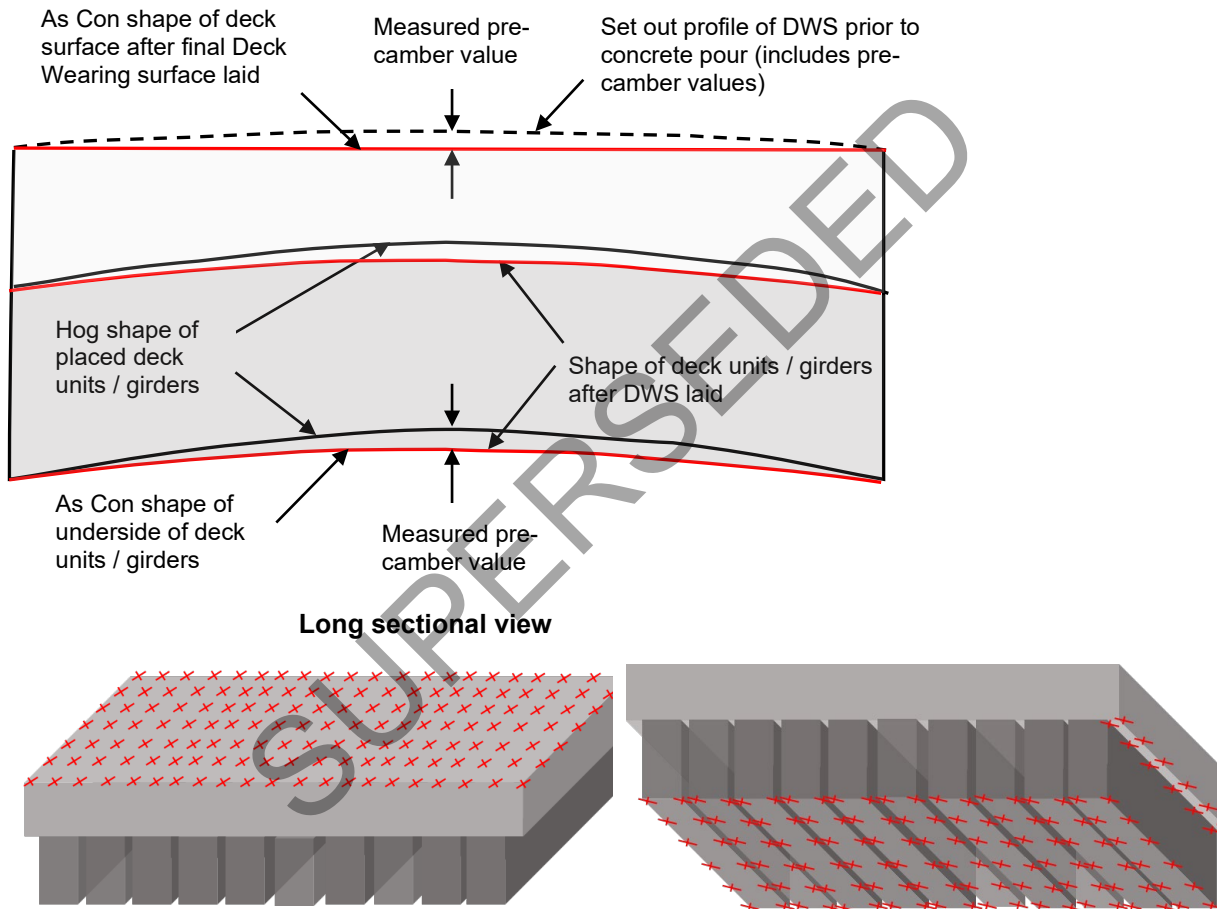

If unable to measure the underside of the girders / deck units, calculate the pre-camber values from the differences between the set out height deck surface and As Constructed deck surface height values. Use the same pre-camber values and dimensions of the girders / deck units to derive the underside shape of the girders / deck units.

Figure 11.12.7(b) - As Constructed Survey of deck surface only

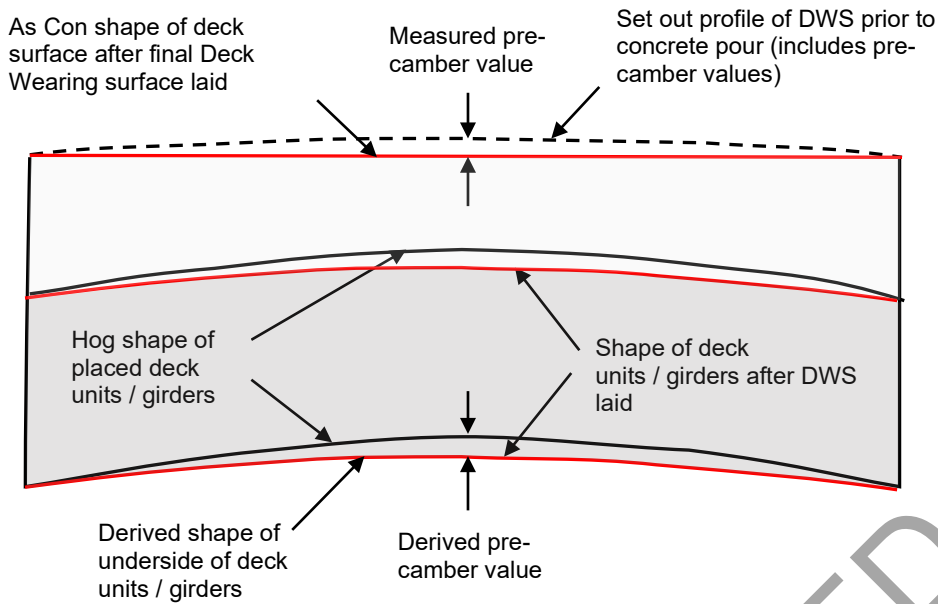

11.12.8 Kerbs, parapets and relieving slabs

After kerbs, parapets and relieving slab Works have been completed in accordance with MRTS77 *Bridge Deck* or associated drawings and documentation, an As Constructed Survey shall be undertaken. An as constructed model of the kerbs / parapets can be constructed from an As Constructed Survey.

A sufficient number of capture points along the edges of the kerb / parapet will enable the construction of a 3D electronic model for this component.

Guard rail and post detail are ancillary components of the bridge and require as constructed positional capture to meet current *TMR Surveying Standards* requirements. Unless the detail of these components is captured by a 3D Laser Scanning device, it is not a requirement to include this data as part of being able to create a 3D As Constructed Survey model.

Figure 11.12.8(a) - As Constructed Survey of kerbs and parapets

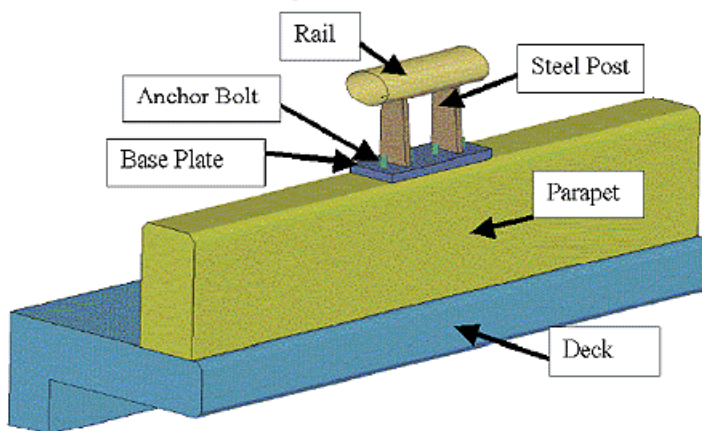

An As Constructed Survey Model of the relieving slabs can be constructed from an As Constructed Survey.

The relieving slab is usually constructed as part of road contract Works. As the relieving slab is poured insitu, an As Constructed Survey of the prepared surface is required before the concrete pour to create the underside shape of the relieving slab.

Figure 11.12.8(b) - As Constructed Survey of relieving slabs

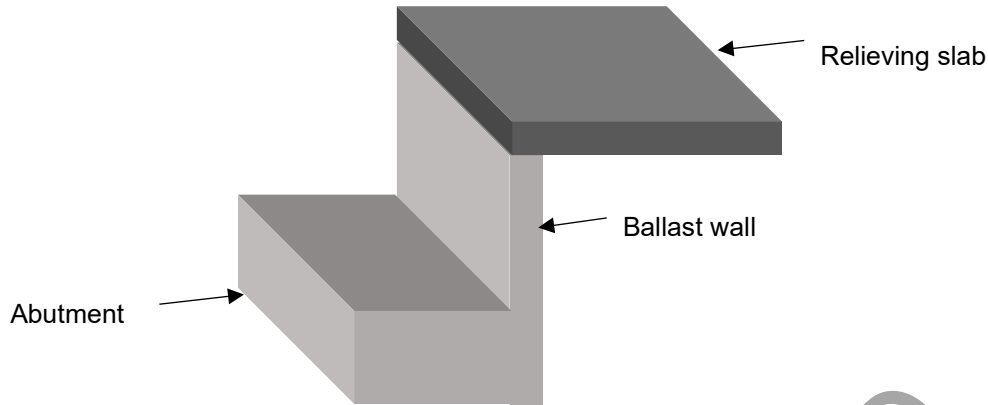

12 Compliance / Conformance reporting results

There are no prescribed methods of how conformance results should be represented. The examples shown under this clause may be accepted by the Administrator.

Note: If 3D laser scanning techniques have been used to undertake an As Constructed Survey of the constructed objects throughout the construction process then conformance reporting results to produce heat mapping techniques using surveying and design software may be used as an additional visual tool to compare between the As Constructed Survey surface and the design surface or creating isopach maps (contours) of the height differences (the thickness) between two surfaces.

12.1 Earthworks

Conformance reporting results to compare against the positional, height and relative tolerances for earthworks must meet the requirements in accordance with MRTS04 *General Earthworks*, associated drawings and contract documents.

Note: Although conformance reporting results are generally only required at 20 m intervals, it may be more practical to report these at 10 m intervals to align with the As Constructed Survey information if this is acceptable to the Administrator.

12.1.1 Topsoil stripping area

After topsoil stripping Works have been completed in accordance with MRTS04 *General Earthworks* or associated drawings and documentation, the measured results for clearing limits are to be derived from the As Constructed Survey and drawings. There are no tolerance requirements for the clearing limits or prescribed methods of how the clearing limit results should be represented.

12.1.2 Bottom of excavations

After excavation Works have been completed in accordance with MRTS04 *General Earthworks* or associated drawings and documentation, the conformance results for location and tolerances are to be derived from the As Constructed Survey and associated drawings.

The minimum requirement is to provide conformance results for location and height of the excavated area.

An example of typical location and height conformance results can be shown in tabular form as shown in Table 12.1.2.

Table 12.1.2 - Example of typical location and height conformance results for excavated areas

Location and height conformance results from As Constructed (AsCon) survey bottom of excavation					In tolerance	
					Out of tolerance	
Ch	Design O/S	As Con O/S	Diff O/S	Design Height	As Con Height	Height Diff
130200	-10.000	-10.200	0.200	94.700	94.718	0.018
130200	-7.500	-7.450	-0.050	95.525	95.517	-0.008
130200	-3.750	-3.748	-0.002	95.638	95.645	0.007
130200	0.000	0.030	-0.030	95.750	95.755	0.005
130200	3.750	3.720	0.030	95.638	95.635	-0.002
130200	7.500	7.498	0.002	95.525	95.505	-0.020
130200	10.000	9.953	0.047	94.700	94.685	-0.015

Figure 12.1.2 - Typical cross section of As Constructed Survey and conformance locations for excavated area

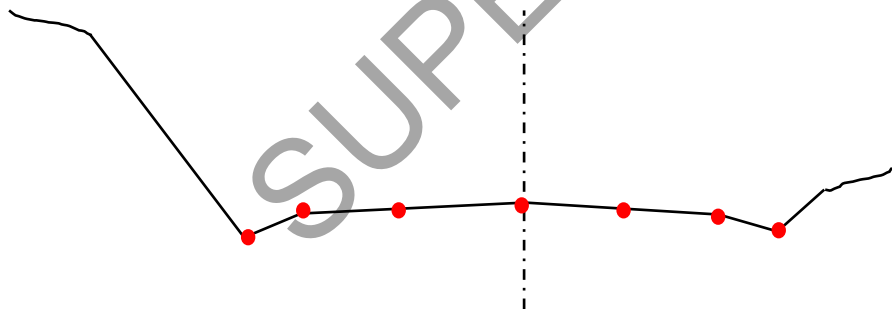

12.1.3 Excavations for unsuitable material

After excavation Works for unsuitable material have been completed in accordance with MRTS04 *General Earthworks* or associated drawings and documentation, the conformance results for location and height are to be derived from the As Constructed Survey and associated drawings.

An example of typical location and height conformance results can be shown in tabular form as shown in Table 12.1.2.

12.1.4 Excavation areas for end structures

After excavation Works for areas for end structures have been completed in accordance with MRTS04 *General Earthworks* or associated drawings and documentation, the conformance results for location and heights are to be derived from the As Constructed Survey and associated drawings.

An example of typical location and height conformance results can be shown in tabular form as shown in Table 12.1.2.

12.1.5 Embankments prior to construction of the subgrade

After embankment Works have been completed prior to construction of the subgrade in accordance with MRTS04 *General Earthworks* or associated drawings and documentation, the conformance results for location and tolerances are to be derived from the As Constructed Survey and associated drawings.

An example of typical location and height conformance results can be shown in tabular form as shown in Table 12.2.1.

12.1.6 Stabilised subgrades

After stabilisation Works for the subgrade have been completed in accordance with MRTS04 *General Earthworks* and MRTS07A *In situ Stabilised Subgrades using Quicklime or Hydrated Lime* or associated drawings and documentation, the conformance results for location and heights are to be derived from the As Constructed Survey and associated drawings.

An example of typical location, height and subgrade thickness conformance results can be shown in tabular form as shown in Table 12.2.1.

12.1.7 Excavation for channels and drains

After excavation Works for channels and drains have been completed in accordance with MRTS04 *General Earthworks*, MRTS03 *Drainage, Retaining Structures and Protective Treatments* and MRTS38 *Pavement Drains* or associated drawings and documentation, the conformance results for location and height are to be derived from the As Constructed Survey and associated drawings.

An example of typical location and height conformance results can be shown in tabular form as shown in Table 12.1.2.

12.2 Pavement, pavement drains, kerb, channel and kerb and channel

Conformance reporting results to compare against the positional, dimensional and relative tolerances for pavement layers must meet the requirements in accordance with all the relevant Transport and Main Roads Technical Specification documents, associated drawings and contract documents.

Note: Although conformance reporting results are generally only required at 20 m intervals, it may be more practical to report these at 10 m intervals to align with the As Constructed Survey information if this is acceptable to the Administrator.

12.2.1 Pavement layers

After pavement layer Works have been completed in accordance with MRTS05 *Unbound Pavements*, MRTS07B *In situ Stabilised Pavements using Cement or Cementitious Blends*, MRTS07C *In situ Stabilised Pavements using Foamed Bitumen*, MRTS08 *Plant-Mixed Heavily Bound (Cemented) Pavements*, MRTS09 *Plant-Mixed Foamed Bitumen Stabilised Pavements*, MRTS10 *Plant-Mixed Lightly Bound Pavements*, MRTS30 *Asphalt Pavements* and MRTS32 *High Modulus Asphalt (EME2)* or associated drawings and documentation, the conformance results for location and tolerances are to be derived from the As Constructed Survey and associated drawings.

The minimum requirement is to provide conformance results for location, height, crossfall and pavement thickness of the constructed pavement layers.

An example of typical location, height conformance and pavement thickness results can be shown in tabular form as shown in Table 12.2.1.

Graphical representations for turnouts intersections including roundabouts maybe more suitable.

Table 12.2.1 - Example of typical location and height conformance results for pavement layers

Location and height conformance results from As Constructed (AsCon) survey of a typical pavement layer										In tolerance	
										Out of tolerance	
Design Ch	As Con Ch	Design O/S	As Con O/S	Diff O/S	Design height	As Con height	Height diff	Design cross fall	Diff in cross fall	Subgrade height	Pavement thickness
130200	130200.003	-7.900	-7.940	0.040	94.700	94.720	0.020				
130200	130199.998	-7.000	-7.050	0.050	95.000	95.011	0.011	3.00%	-	94.702	0.309
130200	130200.012	-3.500	-3.450	-0.050	95.105	95.102	-0.003	3.00%	-0.47%	94.800	0.302
130200	130199.995	-0.500	-0.505	0.005	95.195	95.193	-0.002	3.00%	0.09%	94.887	0.306
130200	130200.025	0.500	0.550	-0.050	95.195	95.197	0.002	3.00%	-	94.899	0.298
130200	130200.020	3.500	3.550	-0.050	95.105	95.102	-0.003	3.00%	-0.17%	94.803	0.299
130200	130200.001	7.000	7.005	-0.005	95.000	94.997	-0.003	3.00%	-0.04%	94.699	0.298
130200	130200.005	7.900	7.960	-0.060	94.700	94.68	-0.020				

Table 12.2.1 is an example only. There are no prescribed methods of how As Constructed Survey and conformance results should be represented.

Note: To ensure true crossfall results are obtained, particular care should be taken on steep vertical longitudinal alignments that all crossfall measurements are as close to the same chainage as possible.

Figure 12.2.1 - Typical cross section of As Constructed Survey and conformance locations for pavement layers

Measurement locations should always be taken at the same chainage and offset dimensions to ensure accurate thickness results

- Pavement layer measurement locations
- Previous subgrade measurement locations

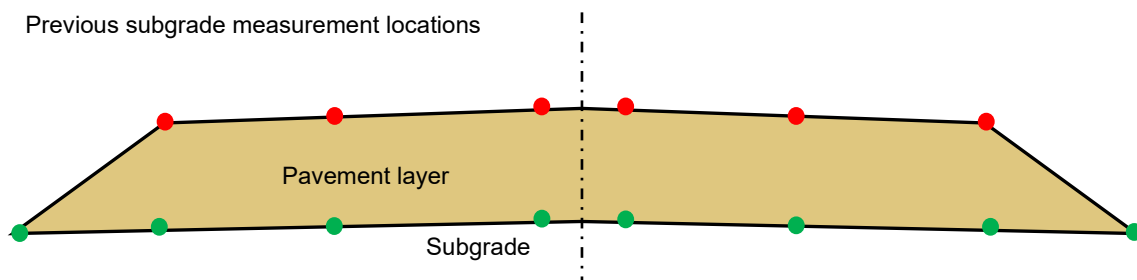

12.2.2 Kerb, channel and kerb and channel

After kerbs, channel and kerb and channel Works have been completed in accordance with MRTS03 *Drainage, Retaining Structures and Protective Treatments* the conformance results for location and tolerances are to be derived from the As Constructed Survey.

The minimum requirement is to provide conformance results for location and height kerb top or kerb lip or top of kerb and kerb lip of the constructed kerbs, channel and kerb and channel.

12.2.3 Footpath and pram crossing

After footpath and pram crossing Works have been completed in accordance with MRTS03 *Drainage, Retaining Structures and Protective Treatments* the conformance results for location and tolerances are to be derived from the As Constructed Survey.

The minimum requirement is to provide conformance results for location, dimensional and height of the constructed footpath and for pram crossings, the location, dimensional and the ramp gradient.

12.2.4 Pavement drains

After pavement drain Works have been completed in accordance with MRTS38 Pavement Drains the conformance results for location and tolerances are to be derived from the As Constructed Survey.

The minimum requirement is to provide conformance results for location and height of the constructed pavement drain.

12.3 Drainage

Conformance reporting results to compare against the positional and height tolerances for drainage Works must meet the requirements in accordance with MRTS03 *Drainage, Retaining Structures and Protective Treatments*, associated drawings and contract documents.

12.3.1 Drainage systems and culverts

After installation Works for drainage systems and culverts have been completed in accordance with MRTS03 *Drainage, Retaining Structures and Protective Treatments* or associated drawings and documentation, the conformance results for location and tolerances are to be derived from the As Constructed Survey and associated drawings.

The minimum requirement is to provide conformance results for location and heights of the installed drainage.

An example of typical location and height conformance results can be shown in tabular form as shown in Table 12.3.1.

Table 12.3.1 - Typical example of location and height conformance results for a drainage system

Location and height conformance results of drainage system								In tolerance	Out of tolerance
Drain Design Chainage	As Con Chainage	Chainage Diff	Offset	As Con offset	Design height top pipe	As Con height top of pipe	Height Diff	Design Gradient	Diff in gradient
1.00	0.950	-0.050	0.000	0.070	10.056	10.050	-0.006		
5.00	4.950	-0.050	0.000	0.053	10.036	10.032	-0.004	-0.50%	-0.05%

Location and height conformance results of drainage system								In tolerance	
								Out of tolerance	
Drain Design Chainage	As Con Chainage	Chainage Diff	Offset	As Con offset	Design height top pipe	As Con height top of pipe	Height Diff	Design Gradient	Diff in gradient
15.00	15.005	0.005	0.000	0.036	9.986	9.983	-0.003	-0.50%	-0.01%
19.00	19.015	0.015	0.000	0.020	9.966	9.964	-0.002	-0.50%	-0.03%

12.3.2 Gullies

After installation Works for gullies have been completed in accordance with MRTS03 *Drainage, Retaining Structures and Protective Treatments* or associated drawings and documentation, the conformance results for location and tolerances are to be derived from the As Constructed Survey and associated drawings.

The minimum requirement is to provide conformance results for location and heights of the installed gullies.

An example of typical location and height conformance results can be shown in tabular form as shown in Table 12.3.2.

Table 12.3.2 - Typical example of location and height conformance results for gullies

Location and height conformance results of gullies										In tolerance	
										Out of tolerance	
Road Chainage	As Con Chainage	Chainage Diff	Offset	As Con offset	Diff	Design invert	As Con invert	Diff	Design frame Height	As Con fame Height	Diff
10200.00	10200.085	0.085	6.850	6.808	-0.042	10.050	10.021	-0.029	10.950	10.955	0.005

12.3.3 Access chambers

After installation Works for access chambers have been completed in accordance with MRTS03 *Drainage, Retaining Structures and Protective Treatments* or associated drawings and documentation, the conformance results for location and tolerances are to be derived from the As Constructed Survey and associated drawings.

The minimum requirement is to provide conformance results for location and heights of the installed access chambers.

12.3.4 Subsoil drains

After installation Works for subsoil drains have been completed in accordance with MRTS03 *Drainage, Retaining Structures and Protective Treatments* or associated drawings and documentation, the conformance results for location and tolerances are to be derived from the As Constructed Survey and associated drawings.

12.3.5 Vertical drains

After installation Works for vertical drains have been completed in accordance with MRTS03 *Drainage, Retaining Structures and Protective Treatments* or associated drawings and

documentation, the conformance results for location and tolerances are to be derived from the As Constructed Survey and associated drawings.

12.4 Subsurface footings

Conformance reporting results to compare against the positional and height tolerances for drainage Works must meet the requirements in accordance with MRTS03 *Drainage, Retaining Structures and Protective Treatments*, MRTS63A *Piles for Ancillary Structures*, MRTS15 *Noise Fences*, MRTS92 *Traffic Signal and Road Light Footings* and associated drawings and contract documents.

12.4.1 Retaining wall pad / strip footings

Conformance reporting results to compare against the positional and heights for retaining walls must meet the tolerances in accordance with MRTS03 *Drainage, Retaining Structures and Protective Treatments*, associated drawings and contract documents.

After installation Works have been completed in accordance with MRTS03 *Drainage, Retaining Structures and Protective Treatments* or associated drawings and documentation, the conformance results for location and heights are to be derived from the As Constructed Survey and associated drawings.

An example of typical location and height conformance results can be shown in tabular form as shown in Table 12.4.1(a) and (b).

Table 12.4.1(a) - Example of typical location and height conformance results of excavated footing area

Location and height conformance results of excavated footing area					In tolerance	
					Out of tolerance	
Ch	Design O/S	As Con O/S	Diff O/S	Design Height	As Con Height	Height Diff
130200	-10.000	-10.004	0.004	92.050	92.058	0.008
130200	-12.000	-11.995	-0.005	92.050	92.053	0.003

Table 12.4.1(b) - Example of typical location and height conformance results of constructed footing

Location and height conformance results of footing					In tolerance	
					Out of tolerance	
Ch	Design O/S	As Con O/S	Diff O/S	Design Height	As Con Height	Height Diff
130200	-10.000	-9.995	-0.005	92.250	92.255	0.005
130200	-10.500	-10.505	0.005	92.250	92.249	-0.001
130200	-11.500	-11.505	0.005	92.250	92.248	-0.002
130200	-12.000	-12.003	0.003	92.250	92.251	0.001

Figure 12.4.1 - Typical cross section of As Constructed Survey and conformance locations of concrete retaining wall

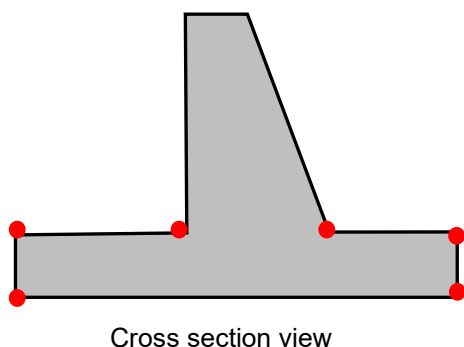

12.4.2 Ancillary structure pile footings

After installation of ancillary pile footings has been completed in accordance with MRTS63A *Piles for Ancillary Structures* or associated drawings and documentation, the conformance results for location and tolerances are to be derived from the As Constructed Survey and associated drawings.

The minimum requirement is to provide conformance results for location and heights of the installed pile footings.

12.4.3 Noise fence footings

After excavation Works and installation noise fence footings has been completed in accordance with MRTS15 *Noise Fences* or associated drawings and documentation, the conformance results for location and tolerances are to be derived from the As Constructed Survey and associated drawings.

The minimum requirement is to provide conformance results for location, depth and top of the installed footings.

12.4.4 Traffic signal and road lighting footings

After excavation Works and installation of traffic signal and road lighting footings have been completed in accordance with MRTS92 *Traffic Signal and Road Lighting Footings* or associated drawings and documentation, the conformance results for tolerances are to be derived from the As Constructed Survey and associated drawings.

The minimum requirement is to provide conformance results for required location, depth and top of the installed footing.

12.4.5 Load bearing footings

After excavation Works for load bearing footings has been completed in accordance with MRTS04 *General Earthworks* or associated drawings and documentation, and installation of the load bearing footings have been completed, the conformance results for tolerances are to be derived from the As Constructed Survey and associated drawings.

The minimum requirement is to provide conformance results for required location, depth and top of the installed footing.

12.4.6 Concrete masonry / Crib wall footings

After construction of concrete masonry / crib wall footings have been completed in accordance with MRTS03 *Drainage, Retaining Structures and Protective Treatments* or associated drawings and

documentation, the conformance results for tolerances are to be derived from the As Constructed Survey and associated drawings.

The minimum requirement is to provide conformance results for required location, depth and top of the installed footing.

12.5 Conduits and pits

After installation of the conduits have been completed in accordance with MRTS91 *Conduits and Pits* or associated drawings and documentation, the conformance results for location and tolerances are to be derived from the As Constructed Survey and associated drawings.

The minimum requirement is to provide conformance results for location requirements within allocated alignment corridors, depth of cover and below the subgrade in road crossings.

12.6 Retaining walls (above ground)

Conformance reporting results to compare against the positional and heights for retaining walls must meet the tolerances in accordance with MRTS03 *Drainage, Retaining Structures and Protective Treatments*, associated drawings and contract documents.

After installation Works have been completed in accordance with MRTS03 *Drainage, Retaining Structures and Protective Treatments* or associated drawings and documentation, the conformance results for location and heights are to be derived from the As Constructed Survey and associated drawings.

An example of typical location and height conformance results can be shown in tabular form as shown in Table 12.6.

Table 12.6 - Example of typical location and height conformance results of top of retaining wall

Location and height conformance results of top wall					In tolerance	
					Out of tolerance	
Ch	Design O/S	As Con O/S	Diff O/S	Design Height	As Con Height	Height Diff
130200	-11.000	-11.008	0.008	94.250	94.235	-0.015
130200	-11.500	-11.501	0.001	94.250	94.237	-0.013

Figure 12.6 - Typical cross section example of As Constructed Survey and conformance location for top of retaining wall

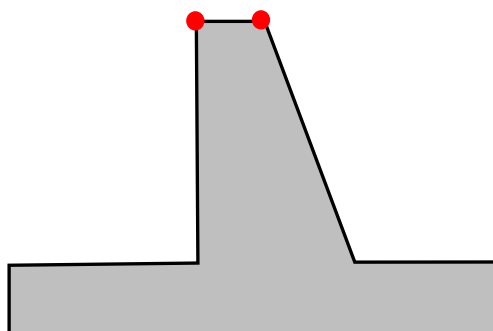

Cross section view

12.7 Bridges

Conformance reporting results to compare against the positional, dimensional and relative tolerances for bridges must meet the requirements in accordance with all the relevant Main Roads Technical Specification documents, associated drawings and contract documents.

12.7.1 Piles

After pile Works have been completed in accordance with MRTS63 *Cast in Place Piles* or MRTS65 *Precast Prestressed Concrete Piles* or MRTS66 *Driven Steel Piles* or associated drawings and documentation, the conformance results for location are to be derived from the As Constructed Survey and associated drawings.

Conformance results can be represented by tables or graphically by calculating the vector between the pile design location coordinates and the As Constructed Survey location coordinates. And then calculating the departure offset dimensions from the bridge pier alignment. See examples in Figure 12.7.1(a) and (b).

Figure 12.7.1 - Example of As Constructed Survey and conformance results of piles

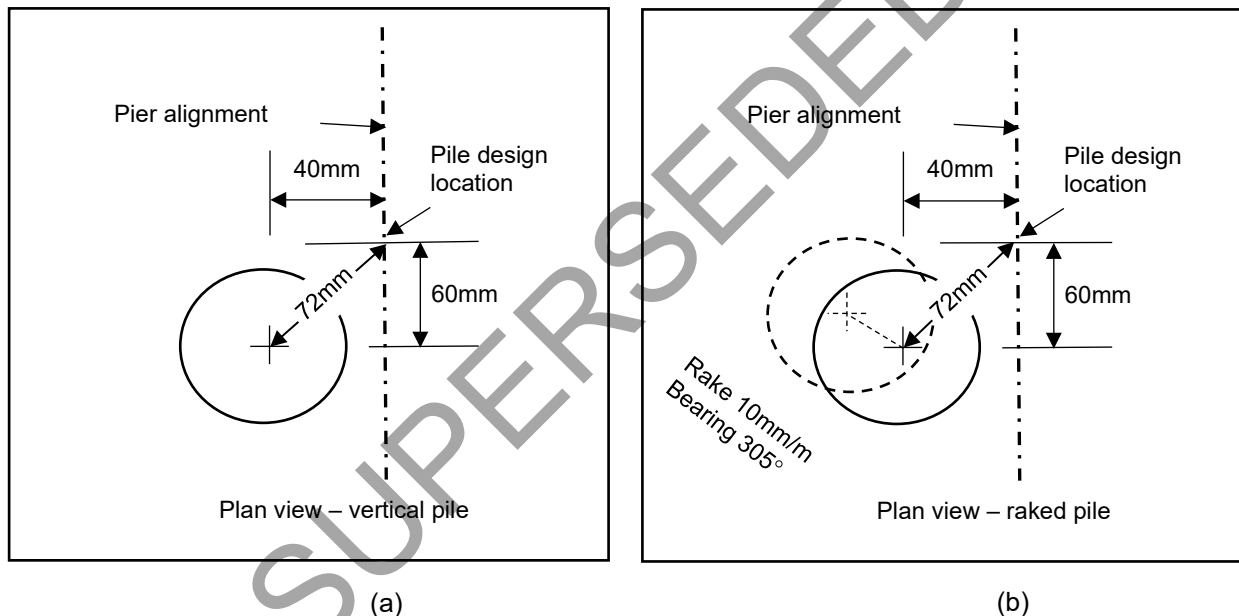

12.7.2 Pile caps, pier columns, abutments and headstocks

After pile caps, pier columns, abutments and headstock Works have been completed in accordance with MRTS70 *Concrete*, MRTS62 *Bridge Substructure* and MRTS73 *Manufacture of Prestressed Concrete Members and Stressing Units* or associated drawings and documentation, the conformance results for location and tolerances are to be derived from the As Constructed Survey and associated drawings.

The minimum requirement is to provide conformance results for location, height, dimensional and linearity or planarity (shape) of the constructed elements.

For circular pier columns determine the centre of the pier from the As Constructed Survey and represent the positional location in the same manner for piles as shown in Clause 11.12.1.

12.7.2.1 Conformance positional and height location results

Figure 12.7.2.1 - Example of As Constructed Survey and conformance locations of pile caps / pier columns / abutments and headstocks

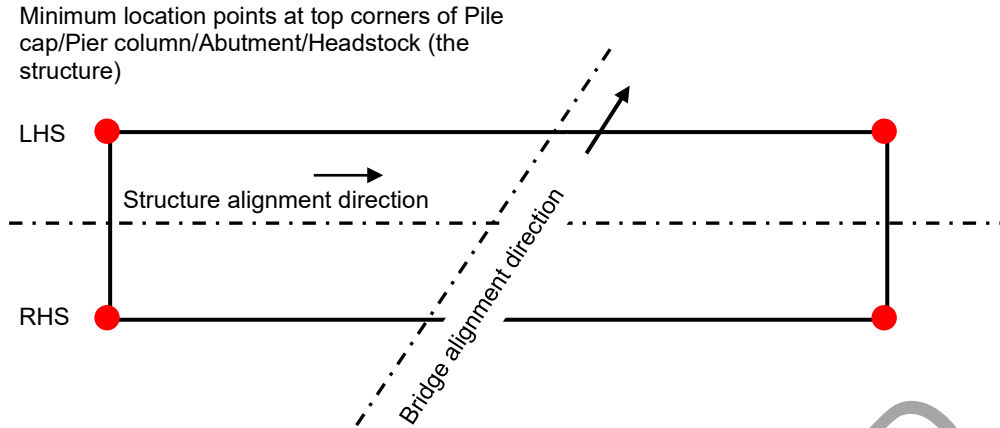

An example of typical location and height conformance results can be shown in tabular form as shown in Table 12.7.2.1.

Table 12.7.2.1 - Example of typical location and height conformance results of headstock

Location and height conformance results from As Constructed (AsCon) survey (Structure chainage is in the direction as shown on the drawings and assumed to be 0.000 at intersection of structure and bridge alignments)								In tolerance	
								Out of tolerance	
	Design Ch	As Con Ch	Ch Diff	Design O/S	AsCon O/S	O/S Diff	Design Height	As Con Height	Height Diff
LHS	-7.500	-7.492	-0.008	-0.750	-0.746	-0.004	145.554	145.552	-0.002
	+7.500	+7.513	+0.013	-0.750	-0.746	-0.004	144.954	144.955	+0.001
RHS	-7.500	-7.496	-0.004	+0.750	+0.753	+0.003	145.554	145.553	-0.001
	Line measurement on Face			+0.750	+0.757	+0.007	145.640	145.641	+0.001
	+7.500	+7.508	+0.008	+0.750	+0.756	+0.006	144.954	144.956	+0.002

The same approach can be applied at bottom corners of the constructed element.

For compliance testing measurement, the resulting edge derived from the intersection of the adjacent projected chamfered faces is required. See Clause 11.12.2.

12.7.2.2 Conformance dimensional results

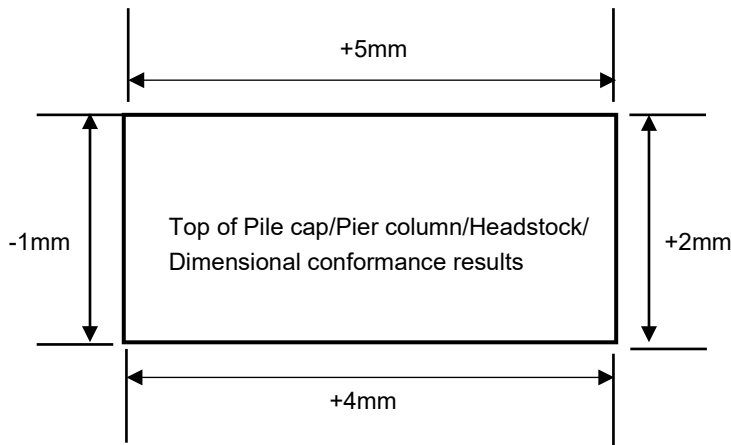

Dimensional conformance results in Table 12.7.2.2 can be derived from Table 12.7.2.1.

Table 12.7.2.2 - Example of dimensional conformance results of pile cap / pier column / headstock

Dimensional conformance results		In tolerance	
		Out of tolerance	
Length dimension difference LHS pier alignment (Add Ch diff LHS)	+0.005	Width dimension difference LHS of bridge alignment (Add O/S diff between LHS and RHS)	-0.001
Length dimension difference RHS pier alignment (Add Ch diff RHS)	+0.004	Width dimension difference RHS of bridge alignment (Add O/S diff between LHS and RHS)	+0.002

12.7.2.3 Conformance linearity or planarity (shape) results

The same approach can be applied for conformance linearity or planarity results by measuring along the top / side/bottom edges of the constructed element at regular 1 – 2 m intervals for chainage and offsets only.

Figure 12.7.2.3 - Example of linearity or planarity As Constructed Survey and conformance locations for headstock

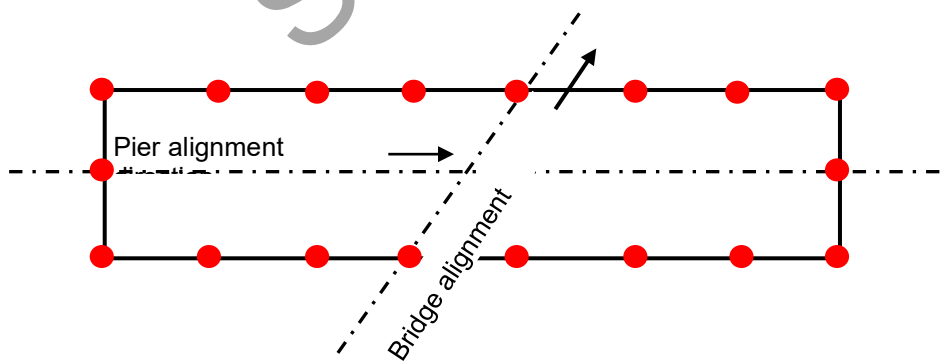

12.7.2.4 Coreholes and fitment for prefabricated elements

After abutments and headstock Works have been completed in accordance with MRTS70 Concrete or associated drawings and documentation, the conformance results for location for the coreholes are to be derived from the As Constructed Survey and associated drawings.

An example of typical location core hole and fitment for prefabricated girders / deck units conformance results can be shown in tabular form as shown in Table 12.7.2.4.

Table 12.7.2.4 - Example of typical location and fitment conformance corehole results

Location core hole conformance results (Pier chainage is 0.000 at intersection of pier and bridge alignments and in the direction as shown on the drawings)									In tolerance		
									Out of tolerance		
	Core hole No.	Design Ch	As Con Ch	Ch Diff	Design O/S	As Con O/S	O/S Diff	Core hole No's.	Lateral Diff	Core hole No's.	Long Diff
LHS Pier 1	1	-2.500	-2.507	+0.007	-0.350	-0.345	-0.005				
	2	-1.500	-1.503	+0.003	-0.350	-0.352	+0.002	1-2	-0.002		
	3	-0.500	-0.495	-0.005	-0.350	-0.354	-0.006	2-3	-0.004		
	4	+0.500	+0.506	+0.006	-0.350	-0.357	+0.007	3-4	+0.001		
	5	+1.500	+1.501	+0.001	-0.350	-0.345	-0.005	4-5	+0.002		
	6	+2.500	+2.506	+0.006	-0.350	-0.356	+0.006	5-6	+0.001		
RHS Pier 2	7	-2.500	-2.493	-0.007	+0.350	+0.347	-0.003			1-7	-0.008
	8	-1.500	-1.505	+0.005	+0.350	+0.358	+0.008	7-8	+0.005	2-8	+0.010
	9	-0.500	-0.495	-0.005	+0.350	+0.352	+0.002	8-9	+0.010	3-9	-0.004
	10	+0.500	+0.498	-0.002	+0.350	+0.347	-0.003	9-10	-0.001	4-10	+0.004
	11	+1.500	+1.502	+0.002	+0.350	+0.356	+0.006	10-11	+0.003	5-11	+0.001
	12	+2.500	+2.498	+0.002	+0.350	+0.354	+0.004	11-12	+0.010	6-12	+0.010

Figure 12.7.2.4 - Example of fitment conformance results of coreholes between abutment / headstock to headstock

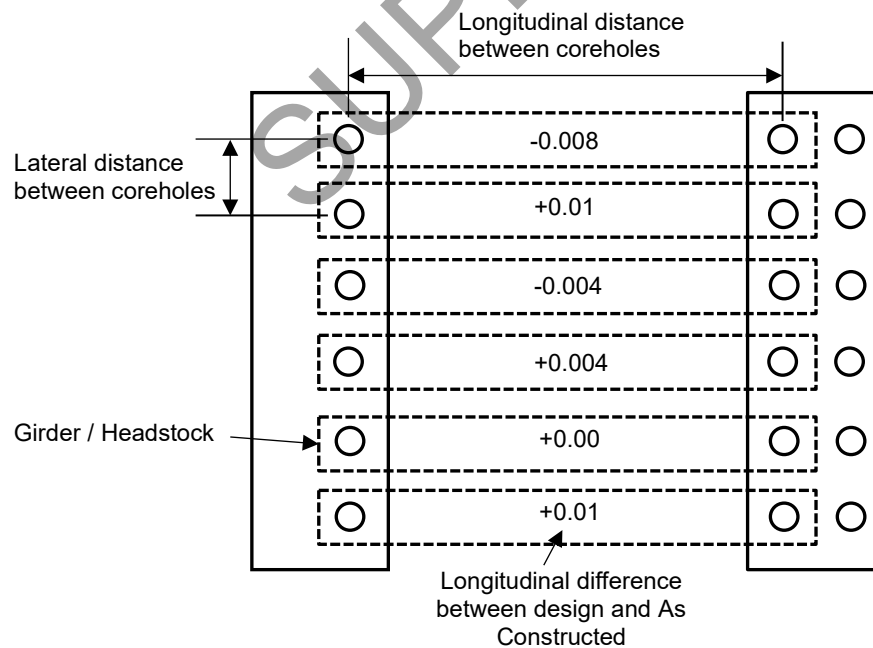

12.7.3 Bearing pedestals / plinths

After bearing pedestal / plinth Works have been completed in accordance with MRTS70 *Concrete* and MRTS62 *Bridge Substructure* or associated drawings and documentation, the conformance results for location and dimensional requirements bearing pedestals / plinths are to be derived from the As Constructed Survey and associated drawings.

Heights measured by level and staff at the corners of the pedestal / plinth can be tabulated as shown in Table 12.7.3 and shown graphically in Figure 12.7.3.

Table 12.7.3 - Example of typical height conformance results of bearing pedestal

Height of Bearing Pedestal Surface			In tolerance	
			Out of tolerance	
	Point #	Design Height	As Constructed Height	Height Differences
Pedestal 1	1	146.372	146.370	-0.002
	2	146.372	146.368	-0.004
	3	146.400	146.399	-0.001
	4	146.400	146.398	-0.002

Figure 12.7.3 - Example of conformance results of bearing pedestal / plinth

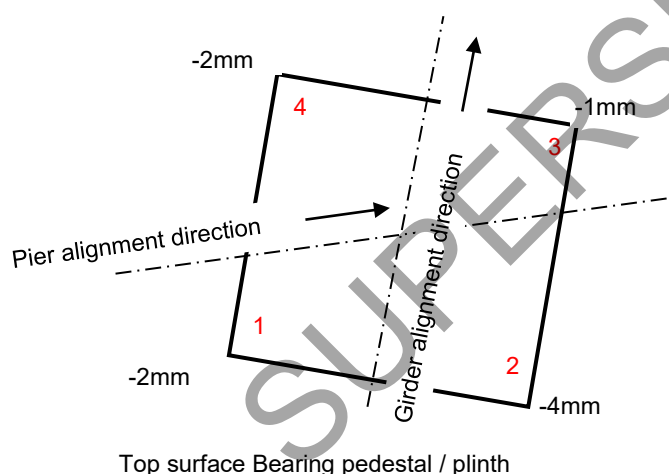

12.7.4 Girders / deck units

After placement girders / deck units have been completed in accordance with MRTS70 *Concrete* and MRTS73 *Manufacture of Prestressed Concrete Members and Stressing Units* or associated drawings and documentation, the conformance results for location and tolerances are to be derived from the As Constructed Survey and associated drawings.

12.7.4.1 Conformance positional and height location results

Apply the same methods as in Clause 12.7.2.1.

12.7.4.2 Hog conformance results

Apply the same methods as in Clause 12.7.2.1 only this time, along the top and bottom edges of the girders/deck units at regular 1 – 2 m intervals.

12.7.4.3 Conformance dimensional results

Apply the same methods as in Clause 12.7.2.2.

12.7.5 Deck

After deck Works have been completed in accordance with MRTS70 *Concrete*, MRTS77 *Bridge Deck* and MRTS84 *Deck Wearing Surface* or associated drawings and documentation, the conformance results for location, finished surface level and deck thickness can be derived from the As Constructed Survey and associated drawings.

An example of Conformance results for a bridge deck with a concrete deck wearing surface (DWS) can be tabulated as shown in Table 12.7.5.

Note: If measured, use the As Constructed Survey values of the bottom of girders / deck units after concrete pour to measure actual pre-camber values, otherwise use the derived pre-camber values from the difference between the set out Final Surface Level (FSL) and the As Constructed Survey of the final deck surface. See Clause 11.2.7.

Table 12.7.5 - Example of typical As Constructed Survey conformance results of a bridge deck

As Constructed Survey of final surface of Bridge Deck							In tolerance	
							Out of tolerance	
Ch	O/S	Design FSL	As Con FSL	Diff. (Design FSL – As Con FSL)	As Con top of girder (pre deck pour)	Derived pre-camber Values	As Con top of girder less pre-camber values	Deck thickness
110.301	-3.515	146.701	146.702	0.001	146.498	0.006	146.489	0.210
110.306	-2.349	146.654	146.650	-0.004	146.462	0.006	146.445	0.194
110.304	-1.178	146.607	146.608	0.001	146.405	0.006	146.393	0.209
110.299	0.015	146.560	146.554	-0.006	146.356	0.006	146.350	0.204
110.307	1.185	146.513	146.512	-0.001	146.306	0.006	146.293	0.212
110.306	2.395	146.466	146.468	0.002	146.260	0.006	146.252	0.214
110.304	3.515	146.419	146.415	-0.004	146.213	0.006	146.207	0.208

Tolerance relaxed for bituminous deck wearing surface (DWS) to ± 20 mm provided that the deck thickness limitations and minimum concrete cover are maintained as specified in MRTS77 *Bridge Deck*.

Figure 12.7.5 - Example of typical plan view of As Constructed Survey and conformance locations across the mid-span of a bridge deck

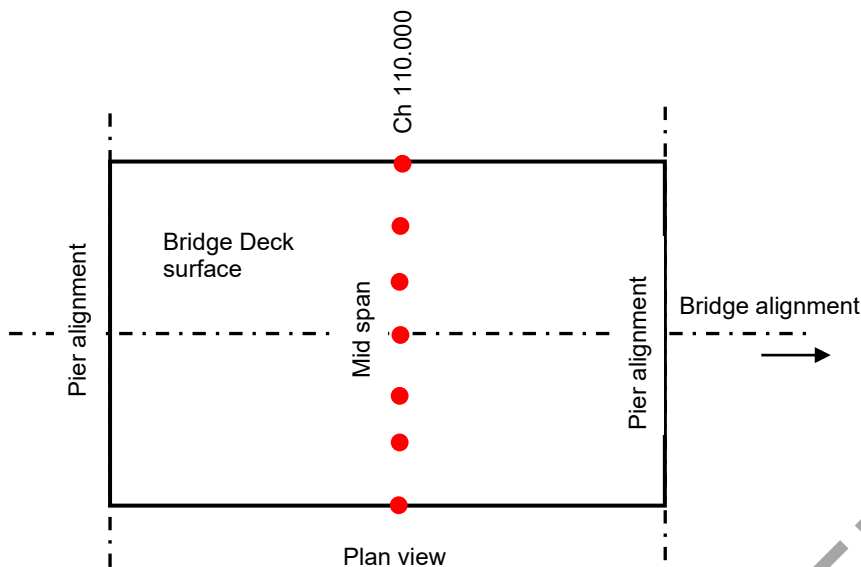

13 Existing underground assets survey

Existing underground assets may be fully or partly exposed during confined excavation Works that have been undertaken in accordance with MRTS04 *General Earthworks*, Trenching Works for MRTS91 *Conduits and Pits* and/or MRTS03 *Drainage, Retaining Structures and Protective Treatments*. No backfilling of the excavated area shall be undertaken until the surveying requirements have been met and notice of such Works (excludes delivery of As Constructed Survey information) provided to the Administrator. **Hold Point 14**

Any remaining temporary Works such as; mass concrete, sheet piles, buried retaining walls and so on, that may be buried within the extent of Works shall be surveyed prior to backfill and notice of such Works (excludes delivery of As Constructed Survey information) provided to the Administrator.

Witness Point 21

Table 13 – Existing underground assets

Clause	Existing Assets Survey	Methodology (includes using appropriate codes as per the <i>TMR Surveying Standards – Schedule 1</i>)	Accuracy* Hz & Vt (mm)
13	Survey any existing underground assets partly or fully exposed during construction	As prescribed in Underground Assets in the <i>TMR Surveying Standards, Part 2</i>	± 25
	Survey any remaining temporary Works	Full extent of buried Works	± 25

* Accuracies are stated in terms of 'relative uncertainty' at 95% confidence level.

14 Volume surveys

14.1 Constructed feature volume

Where volumes (cut or fill) is required of a constructed feature (for example, embankment and pavement layers), use the 'TIN to TIN' method using the As Constructed Survey and/or other methods using As Constructed Survey (for example, trimeshes).

14.2 Stockpile volume

Surveys to calculate a stockpile volume shall be undertaken by methods and equipment that enable the accuracy requirements stated in Section 1.3.1.4 Accuracies for 'Other' feature points to be met (see Volume Survey - *TMR Surveying Standards*).

15 Deliverables

As Constructed Survey information shall be submitted on a monthly basis to the Administrator and emailed copies to TMR_Spatial_Enquiry@tmr.qld.gov.au:

Note: All contractual matters must be communicated through the Administrator.

Prior to the Date of Practical Completion, the Contractor must submit to the Administrator and emailed copies to TMR_Spatial_Enquiry@tmr.qld.gov.au:

- the Survey Control Register; as specified in Section 6.4.2 of the *TMR Surveying Standards, Part 2*
- a current Form 6 that includes a locality sketch and details for any new Permanent Mark that may have been placed. Form 6 may be found at: <https://www.business.qld.gov.au/industries/building-property-development/titles-property-surveying/surveying/standards-forms>
- Conformance and all As Constructed Survey information. **Witness Point 22**
- signed Surveyor Certification for work under the Contract.

Survey information in electronic format shall be provided in 12D TMRarchive file format using the current *TMR Surveying Standards*.

Large email attachments can be sent via a file hosting service (such as OneDrive).

16 Surveying deliverable requirements

The surveying deliverable requirements of MRTS56 *Construction Surveying* can be varied from Clause 2 to Clause 13 using the Annexure MRTS56.1. Table 16(a) can be used as a general guide to items that are mandatory (if applicable) or optional (if applicable) .

Table 16(a) - Surveying requirements

Description	Project type*			
	1	2	3	4
Survey Control (Clause 7)	<input checked="" type="checkbox"/>	<input checked="" type="checkbox"/>	<input checked="" type="checkbox"/>	<input checked="" type="checkbox"/>
As Constructed Survey – Earthworks (Clause 11.2)	<input checked="" type="checkbox"/>	<input type="checkbox"/>	<input type="checkbox"/>	<input type="checkbox"/>
As Constructed Survey – Pavements, pavement drains, kerbs, channel and kerb and channel (Clause 11.3)	<input checked="" type="checkbox"/>	<input type="checkbox"/>	<input type="checkbox"/>	<input type="checkbox"/>
As Constructed Survey – Road furniture (Clause 11.4)	<input checked="" type="checkbox"/>	<input type="checkbox"/>	<input type="checkbox"/>	<input type="checkbox"/>
As Constructed Survey – Drainage (Clause 11.5)	<input checked="" type="checkbox"/>	<input checked="" type="checkbox"/>	<input checked="" type="checkbox"/>	<input checked="" type="checkbox"/>
As Constructed Survey – Subsurface footings (Clause 11.6)	<input checked="" type="checkbox"/>	<input type="checkbox"/>	<input type="checkbox"/>	<input type="checkbox"/>

Description	Project type*			
	1	2	3	4
As Constructed Survey – Traffic Engineering Technology and Systems (TETS) - Conduits and Pits (Clause 11.7)	<input checked="" type="checkbox"/>	<input checked="" type="checkbox"/>	<input checked="" type="checkbox"/>	<input checked="" type="checkbox"/>
As Constructed Survey – Retaining walls (above ground) (Clause 11.8)	<input checked="" type="checkbox"/>	<input type="checkbox"/>	<input type="checkbox"/>	<input type="checkbox"/>
As Constructed Survey – Noise fences (Clause 11.9)	<input checked="" type="checkbox"/>	<input type="checkbox"/>	<input type="checkbox"/>	<input type="checkbox"/>
As Constructed Survey – Horizontal Directional Drilling, Micro tunnelling and Thrust and auger boring (Clause 11.10)	<input checked="" type="checkbox"/>	<input checked="" type="checkbox"/>	<input checked="" type="checkbox"/>	<input checked="" type="checkbox"/>
As Constructed Survey – Third Party underground assets – including Public Utility Plant (PUP) (Clause 11.11)	<input checked="" type="checkbox"/>	<input checked="" type="checkbox"/>	<input checked="" type="checkbox"/>	<input checked="" type="checkbox"/>
As Constructed Survey – Bridges (Clause 11.12)	<input checked="" type="checkbox"/>	<input checked="" type="checkbox"/>	<input checked="" type="checkbox"/>	<input checked="" type="checkbox"/>
Survey of Existing underground assets (Clause 13)	<input checked="" type="checkbox"/>	<input checked="" type="checkbox"/>	<input checked="" type="checkbox"/>	<input checked="" type="checkbox"/>

* Refer to Table 16(b) for a brief description of the project categories in Table 16(a).

Table 16(b) – Project categories

Project Type	Description / Indicators
1	Design and Construct contracts: Collaborative Project Agreement (CPA) - High value - \$100M (minimum) – medium to high risk projects, and Construct only contracts: Transport Infrastructure Contract (TIC-CO) - High value - \$100M (minimum) – medium to high risk projects.
2	Design and Construct contracts: Transport Infrastructure Design and Construct (TIC-DC) - Medium to high value – low to high risk projects, and Construct only contracts: Transport Infrastructure Contract (TIC-CO) – Medium to high value – low to high risk projects.
3	Minor Contracts: Minor Infrastructure (MIC-CO) – Low value / low risk - <\$1M for Non-Prequalified Contractors, and Low value / low to medium risk for \$1M to \$5M for Prequalified Contractors.
4	Maintenance contracts: Road Maintenance Performance Contracts (RMPC) / Road Asset Maintenance Contracts (RAMC) – Low to medium risk, and Minor contracts: Small Scale Minor Works Contract (SSMW) – Low value / low risk <\$80K.

17 Supplementary requirements

The supplementary requirements given in Clause 13 of Annexure MRTS56.1 shall apply.

SUPERSEDED