

Superseded

**Technical Specification**

**Transport and Main Roads Specifications  
MRTS260 Temporary Variable Speed Limit Signs**

**July 2023**



## Copyright

© The State of Queensland (Department of Transport and Main Roads) 2023.

## Licence



This work is licensed by the State of Queensland (Department of Transport and Main Roads) under a Creative Commons Attribution (CC BY) 4.0 International licence.

## CC BY licence summary statement

In essence, you are free to copy, communicate and adapt this work, as long as you attribute the work to the State of Queensland (Department of Transport and Main Roads). To view a copy of this licence, visit: <https://creativecommons.org/licenses/by/4.0/>

## Translating and interpreting assistance



The Queensland Government is committed to providing accessible services to Queenslanders from all cultural and linguistic backgrounds. If you have difficulty understanding this publication and need a translator, please call the Translating and Interpreting Service (TIS National) on 13 14 50 and ask them to telephone the Queensland Department of Transport and Main Roads on 13 74 68.

## Disclaimer

While every care has been taken in preparing this publication, the State of Queensland accepts no responsibility for decisions or actions taken as a result of any data, information, statement or advice, expressed or implied, contained within. To the best of our knowledge, the content was correct at the time of publishing.

## Feedback

Please send your feedback regarding this document to: [tmr.techdocs@tmr.qld.gov.au](mailto:tmr.techdocs@tmr.qld.gov.au)

**Contents**

- 1 Introduction .....1**
- 2 Definition of terms .....1**
- 3 Reference documents .....2**
- 4 Quality system requirements .....3**
  - 4.1 Samples for acceptance .....4
- 5 Functional requirements .....4**
  - 5.1 General operation .....4
  - 5.2 Reliability .....5
  - 5.3 Functional control methods .....5
  - 5.4 Key TVSL operational components and general function .....5
    - 5.4.1 *Hardware* .....6
    - 5.4.2 *Software* .....7
- 6 Technical requirements .....8**
  - 6.1 Device Processor (DP) requirements .....8
  - 6.2 Permissible Frames (PF) .....9
  - 6.3 Frame display time .....9
  - 6.4 Flashing display control .....9
  - 6.5 Watchdog .....9
  - 6.6 Global Positioning System (GPS) .....9
  - 6.7 Directional compass capability .....10
  - 6.8 Turning motion sensor .....10
  - 6.9 Short Range Controller (SRC) .....10
  - 6.10 TVSL Sign Master / Slave pairing .....11
    - 6.10.1 *Master* .....11
    - 6.10.2 *Slave* .....11
  - 6.11 Local Facility Switch (LFS) .....11
    - 6.11.1 *“BLANK Display” mode* .....12
    - 6.11.2 *“Display 40” mode* .....12
    - 6.11.3 *“Display 60” mode* .....13
    - 6.11.4 *“Display 70” mode* .....13
    - 6.11.5 *“Display 80” mode* .....13
    - 6.11.6 *“Display 100” mode* .....13
    - 6.11.7 *“Display 110” mode* .....13
    - 6.11.8 *“Remote” mode* .....13
  - 6.12 Maintenance communications port .....13
- 7 Communication requirements .....14**
  - 7.1 General TVSL communications layout .....14
    - 7.1.1 *Device Processor (DP) and LED display (on the same trailer / concrete block)* .....15
    - 7.1.2 *Master, Slave DP(s) and SRC(s)* .....15
    - 7.1.3 *Configuration software and DP* .....15
  - 7.2 Remote site communications .....16
    - 7.2.1 *DP and RSCS* .....16
    - 7.2.2 *DP and critical alert SMS notification system* .....17

7.3	Communications timeout .....	17
7.4	Communications identifiers .....	17
7.4.1	<i>Device Processor (DP) ID</i> .....	18
7.4.2	<i>SRC ID</i> .....	18
<b>8</b>	<b>Software requirements</b> .....	<b>18</b>
8.1	Remote Sign Control System (RSCS) software .....	18
8.1.1	<i>Software user interface and security</i> .....	19
8.2	TVSL configuration / maintenance software (via direct connection) .....	19
8.3	Configuration management .....	20
8.3.1	<i>Device Processor (DP) configuration</i> .....	20
<b>9</b>	<b>TVSL sign monitoring, reporting and alarm requirements</b> .....	<b>20</b>
9.1	Sign monitoring and logs .....	20
9.2	Alarms .....	21
9.3	Critical faults .....	22
<b>10</b>	<b>Mechanical and physical requirements</b> .....	<b>22</b>
10.1	General .....	22
10.2	Trailer .....	23
10.2.1	<i>Static speed limit sign</i> .....	23
10.2.2	<i>Flashing Yellow Alert Light</i> .....	23
10.2.3	<i>Dimensions</i> .....	24
10.2.4	<i>Wind loading</i> .....	25
10.2.5	<i>Storage compartment</i> .....	25
10.2.6	<i>Stabilisers</i> .....	25
10.3	Sign enclosure .....	25
10.3.1	<i>Sign enclosure dimensions</i> .....	25
10.3.2	<i>Doors</i> .....	26
10.3.3	<i>Front cover</i> .....	26
10.3.4	<i>Enclosure material and coatings</i> .....	26
<b>11</b>	<b>Electrical requirements</b> .....	<b>26</b>
11.1	Portable signs .....	26
11.2	Fixed signs .....	27
11.3	Power system monitoring .....	27
<b>12</b>	<b>Sign display requirements</b> .....	<b>27</b>
12.1	Display technology .....	27
12.2	LED output .....	27
12.3	Character format .....	27
12.4	Display changes .....	28
12.5	Display colour .....	28
12.6	Default display .....	28
12.7	Red annulus .....	29
12.8	Flashing display elements .....	29
12.8.1	<i>Flashing partial annulus</i> .....	29
12.8.2	<i>Conspicuity devices</i> .....	29
12.9	Optical performance .....	29

12.9.1	<i>Test procedures</i> .....	29
12.9.2	<i>Luminance</i> .....	30
12.9.3	<i>Luminance intensity half angle</i> .....	30
12.9.4	<i>Sun phantom</i> .....	30
<b>13</b>	<b>Documentation requirements</b> .....	<b>30</b>
<b>14</b>	<b>Testing, configuration and commissioning requirements</b> .....	<b>30</b>
<b>15</b>	<b>Training requirements</b> .....	<b>30</b>
<b>16</b>	<b>Maintenance requirements</b> .....	<b>30</b>
<b>17</b>	<b>Handover requirements</b> .....	<b>30</b>
<b>18</b>	<b>Type approval Checklist</b> .....	<b>30</b>
	<b>Appendix A – Referenced variables and default settings</b> .....	<b>31</b>
	<b>Appendix B – TVSL sign blanking conditions</b> .....	<b>32</b>
	<b>Appendix C – Full listing of speed limit frame designations</b> .....	<b>33</b>
	<b>Appendix D – Type Approval Compliance Checklist</b> .....	<b>34</b>

Superseded

## 1 Introduction

This Technical Specification defines the design, supply, installation, testing and commissioning, performance, documentation, training, maintenance, and handover requirements for Temporary Variable Speed Limit (TVSL) signs. This Technical Specification shall be read in conjunction with MRTS206 *Provision for Variable Speed Limit and Lane Control Signs*, MRTS01 *Introduction to Technical Specifications*, MRTS50 *Specific Quality System Requirements, Guideline – Traffic Management at Works on Roads* and other Technical Specifications as appropriate.

TVSL signs complying with this Technical Specification shall only be used in accordance with the operational requirements of the *Guideline – Traffic Management at Works on Roads*. This includes the requirement that all changes to the displayed speed on the TVSL Sign are logged as being observed in person or through the use of dedicated camera image. All TVSL sign deployments shall also be protected by concrete barriers or other suitable protection barrier as approved by Traffic Guidance Scheme (TGS).

This Technical Specification forms part of the Transport and Main Roads Specifications Manual.

## 2 Definition of terms

The terms defined in MRTS201 *General Equipment Requirements* apply to this Technical Specification. Additional terminology relevant under this Technical Specification are defined in Table 2 below.

**Table 2 – Definitions**

Term	Definition
ADR	Australian Design Rules (ADRs) are national standards for vehicle safety, anti-theft and emissions.
CAT	Customer Acceptance Test (see MRTS201).
Configuration Software	Control / diagnostic software that runs on a laptop and can control, interrogate and program the DP.
CT	Commissioning Test (see MRTS201).
Default Speed	The speed limit that applies to a location in a TVSL zone when all the TVSL are blank (also known as black-out speed).
DOD	Depth of Discharge.
DP	Device Processor—the internal control processing unit hardware within the TVSL sign unit which undertakes all communication and internal processing tasks required for operation.
Event	Sign status change, frame change, occurrence of a fault in the DP or sign.
FAT	Factory Acceptance Test (see MRTS201).
Frame	Any stable state displayed by a TVSL on its display at any one instance of time that is preceded and followed by a change of state.
GIS	Geographic Information System.
GPS	Global Positioning System.
HMI	Human Machine Interface.
IAT	Installation Acceptance Test (see MRTS201).

Term	Definition
LFS	Local Facility Switch - a key operated device used to manually control operation of the DP.
NATA	National Association of Testing Authorities.
NTP	Network Time Protocol.
OH&S	Occupational Health and Safety.
PF	Permissible Frames - at each TVSL sign location that facilitate safe, non-conflicting traffic movement in a TVSL zone (Selection of permissible frames at a TVSL site is also known as local interlocking).
Pixel	The smallest discreetly controlled light emitting component of the sign dot matrix display.
RPEQ	Registered Professional Engineer of Queensland.
RSCS Software	Remote Sign Control System Software - this is the software system used to remotely operate and monitor the TVSL signs for example, from a Traffic Control Company's Premises.
Site Supervisor	A person duly authorised by the traffic control site contractor or Transport and Main Roads to undertake control and monitoring of the deployed TVSL scheme. No other personnel shall undertake control of a deployed TVSL arrangement.
SRC	Short Range Controller - these are the (hand-held) remotes which can set a TVSL Sign to display a permitted speed limit frame.
STREAMS	The Principal's traffic management system and primary user interface to ITS field devices.
TGS	Traffic Guidance Scheme - refer to MRTS02 <i>Provision for Traffic</i> .
TMC	The Principals' Traffic Management Centre (using STREAMS).
TVSL	Temporary Variable Speed Limit.
TVSL sign	TVSL sign is general the term covering the complete TVLS unit, including the DP, LFS, trailer / concrete block, Sign Display, Batteries, Solar Panels and associated internal electronic and mechanical components.
TVSL Site	The roadwork's location at which a number of co-ordinated TVSL Sign (s) are used to reduce traffic speeds. This may include a TGS approved arrangement of a number of Master / Slave TVSL sign(s) at a TVSL Site.
UHF	Ultra-High Frequency – 300 – 3000 MHz radio frequency spectrum band. See the ACMA website for further information.
VPN	Virtual Private Network.
VSLs	Variable speed limit sign(s) - used to display variable speeds only. Typically pole mounted.
WH&S	Workplace Health and Safety.

### 3 Reference documents

The requirements of the referenced documents listed in Table 3 of MRTS201 *General Equipment Requirements* and Table 3 below apply to this Technical Specification. Where there are inconsistencies between this Technical Specification and referenced MRTS documents, the requirements specified in this Technical Specification take precedence.

**Table 3 – Referenced documents**

Reference	Title
AS 1744	<i>Forms of letters and numerals for road signs</i>
AS 5156	<i>Electronic Speed Limit Signs</i>
AS 60529	<i>Degrees of protection provided by enclosures (IP Code)</i>
AS/NZS 1170.1	<i>Structural Design Actions, Permanent, imposed and other actions</i>
AS/NZS 1170.2	<i>Structural Design Actions, Part 2: Wind Actions</i>
AS/NZS 1664	<i>Aluminium structures</i>
AS/NZS 1665	<i>Welding of aluminium structures</i>
AS/NZS 3000	<i>Electrical installation - building structure and premises (Wiring Rules)</i>
AS/NZS 3012	<i>Electrical installations - Construction and demolition sites</i>
AS/NZS 3100	<i>Approval and test – General requirements for electrical equipment</i>
IS18	<i>QGCIO Information Security Standard</i>
MRTS01	<i>Introduction to Technical Specifications</i>
MRTS02	<i>Provision for Traffic</i>
MRTS50	<i>Specific Quality System Requirements</i>
MRTS201	<i>General Equipment Requirements</i>
MRTS206	<i>Provision of Variable Speed Limit and Lane Control Signs</i>
MRTS245	<i>ITS Telecommunications Network (ITS TN)</i>
MRTS263	<i>Standalone Solar (PV) Power Systems</i>
MUTCD	<i>Queensland Manual of Uniform Traffic Management Devices</i>
TRUM Volume 3 Part 5	<i>Design Guide for Roadside Signs</i>
TC1785 1 & 2	<i>Variable Speed Limit Sign LED display – Square / Rectangle</i>
-	<i>Guideline – Traffic Management at Works on Roads</i>
-	<i>Transport Operations (Road Use Management) Act 1995</i>
-	<i>Transport Operations (Road Use Management – Mass, Dimensions and Loading) Regulation 2005</i>
-	<i>Transport Operations (Road Use Management – Vehicle Standards and Safety) Regulation 2010</i>

#### 4 Quality system requirements

The quality system requirements are defined in MRTS201 *General Equipment Requirements* and apply to this Technical Specification. Additional quality system requirements relevant under this Technical Specification are defined in Table 4. There are no Milestones defined.

**Table 4 – Hold Point, Witness Points and Milestone**

Clause	Hold Point	Witness Point	Milestone
4.1	1. Samples for acceptance (design) 2. Optical performance certification		
10.1	3. Trailer and/or concrete block support structure design documentation		
12.9		1. Optical performance certification	

**4.1 Samples for acceptance**

Requirements of MRTS201 *General Equipment Requirements* apply to this Technical Specification.

A sample TVSL sign for acceptance and optical performance certification shall be provided 28 days prior to sign manufacture. **Hold Point 1**

Detailed designs of the sign layout, fabrication and assembly drawings, calculations, specifications and certifications of TVSL signs and associated components (signed by the Contractor’s RPEQ) must be submitted to the Principal via the Administrator for verification prior to manufacture.

Optical performance test methodology and NATA certification confirming the TVSL sign performance requirements specified in this Technical Specification must be submitted before delivery to Site.

**Hold Point 2**

**5 Functional requirements**

**5.1 General operation**

The use of the TVSL signs shall be in accordance with Chapter 2 of the *Guideline – Traffic Management at Works on Roads* (and have the capability of operating as either:

- Single units as in Figure 5.1(a), or
- a Master and Slave Pair as in Figure 5.1(b)

as defined by the approved Traffic Guidance Scheme (TGS).

**Figure 5.1(a) – Single TVSL sign arrangement**

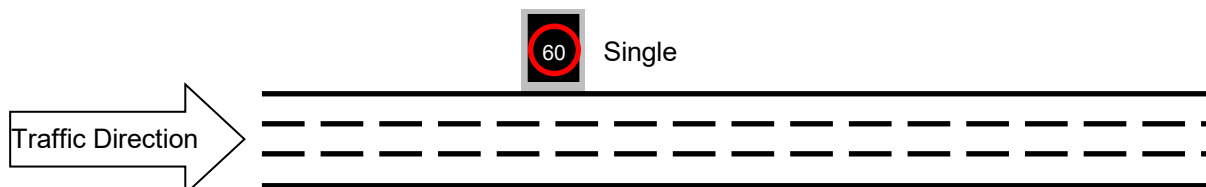

**Figure 5.1(b) – Master and Slave TVSL sign arrangement**

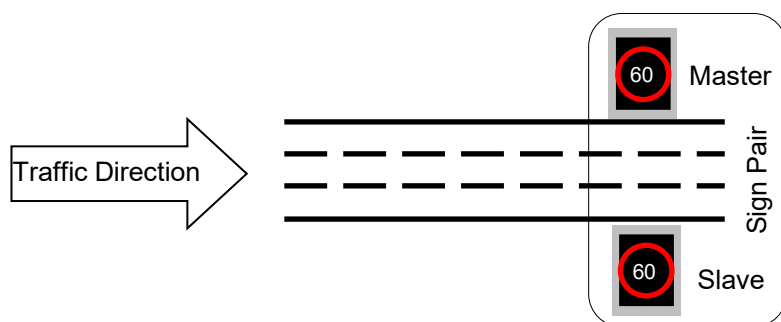

## 5.2 Reliability

All TVSL system shall have a minimum of 99.9% system operating reliability.

## 5.3 Functional control methods

The TVSL shall be operated through the listed methods in the Table 5.3 below.

**Table 5.3 – TVSL control methods**

Control method	Priority
<b>Local Facility Switch (LFS)</b> – Where onsite personnel take manual control of the TVSL Sign	1 (Highest)
<b>Maintenance Port</b> – Onsite at the TVSL Sign	2
<b>Local site hand-held Short-Range Controller (SRC)</b> – Where onsite personnel take local control of the TVSL sign	3
<b>Remote Sign Control System (RSCS)</b> – Where offsite personnel operate the TVSL Sign. This could also be local to the site but via remote communications.	4 (Lowest)

## 5.4 Key TVSL operational components and general function

Figure 5.4 shows the key components associated with TVSL.

Figure 5.4 – Key TVSL components (example Master / Slave configuration)

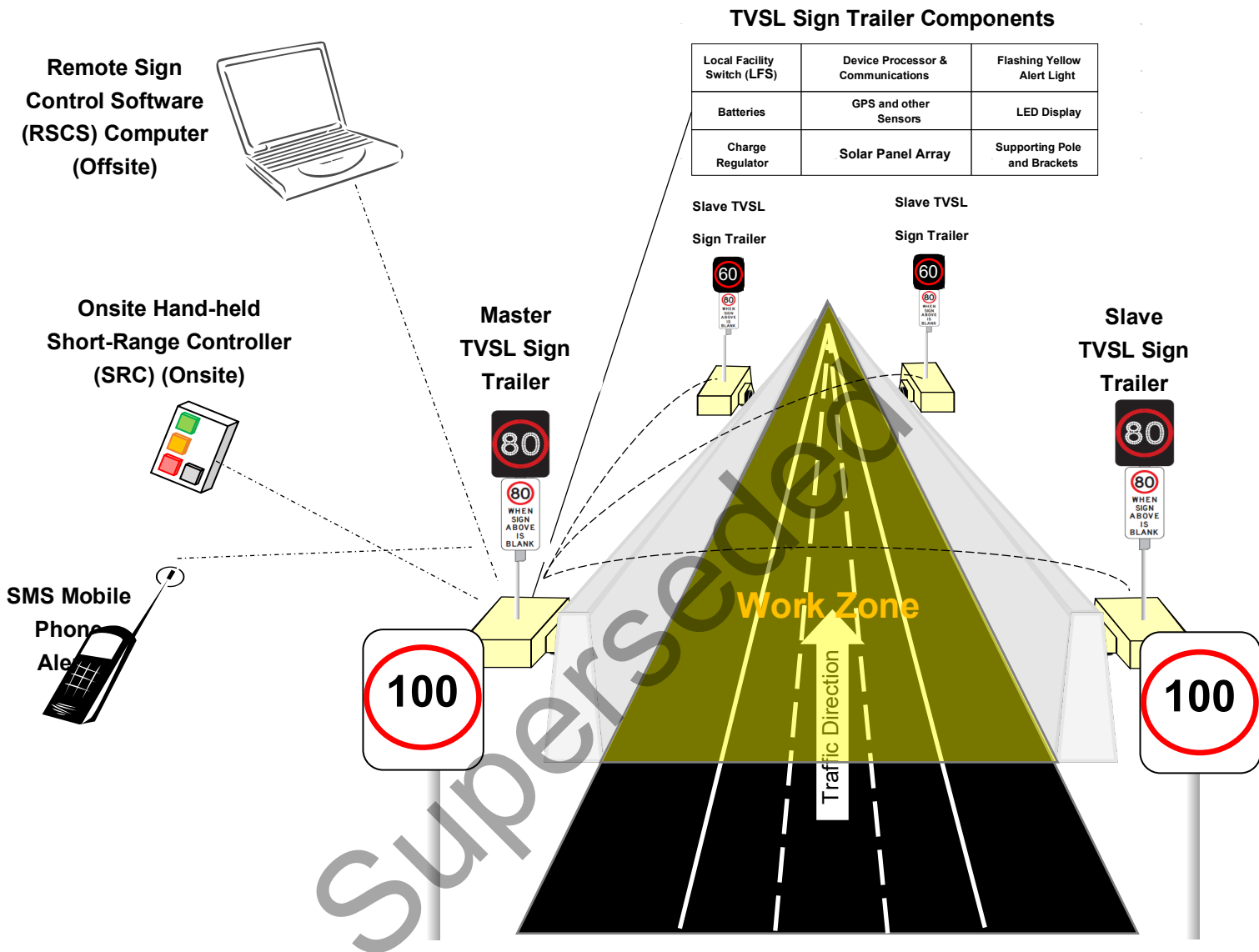

Each component carries out specific functions associated with the operation of the TVSL sign and can be broadly categorised into hardware or software.

#### 5.4.1 Hardware

Table 5.4.1 briefly describes the function of each hardware component.

**Table 5.4.1 – Hardware component functional description**

Item	Brief functional description	Clause
Device Processor (DP)	The DP is a hardware component embedded into the TVSL Sign Trailer. The function of it is to provide the internal processing and communications capability for the TVSL sign trailer	6.1
Movement Sensors	The function of the GPS, compass and gyroscopic movement sensors is to provide periodic monitoring to detect and alert when the TVSL sign has moved from the installed position due to any number of reasons, including accident, theft, slippage and high wind	6.6, 6.7 and 6.8
Short Range Controller (SRC)	The function of the SRC is to provide three modes of operation only—for short range wireless local control mechanism for a TVSL sign or pair of signs at a roadwork site. The SRC is a hand-held device with limited functionality. No administration or configuration operations can be carried out with this device	6.9
Local Facility Switch (LFS)	The function of the LFS is to provide “Remote” and “Blank Display” selections for remote control and to set the blank the TVSL sign display respectively	6.11
Flashing Yellow Alert Light	The function of the flashing yellow alert light is to notify onsite personnel that a TVSL sign has experienced any of the predefined critical failure conditions	9.2 and 10.2.2
Trailer / Base	The function of the trailer or other base, such as a concrete plinth, is to secure in place the TVSL sign and associated components	10
Solar Panel Array	The function of the solar panel array is to charge the TVSL battery storage capacity	11.1
Batteries	The function of the battery bank is to provide sufficient storage for the continuous operation of the TVSL sign during periods of limited sunlight or due to failure of the charging circuitry	11.1
LED Display	The function of the LED display is to illuminate the array of LEDs (Annulus and numeric characters) to display a stored permissible speed limit frame when requested by the DP.	12

#### 5.4.2 Software

There are also several software components associated with the TVSL sign as described below in Table 5.4.2.

**Table 5.4.2 – Software component functional description**

Item	Functional description	Clause
Remote Sign Control System (RSCS) Software	The function of the RSCS software is to control, monitor, administer and manage the connected TVSL signs at roadwork sites using secure wireless communications	8.1

Item	Functional description	Clause
Maintenance / Configuration Software	The function of the maintenance or configuration software for the TVSL sign is to allow the direct connection of a laptop or other compatible device for the purposes of running fault diagnostics, extraction of log local files, local administration tasks and other configuration functions	8.2
Short-Range Controller (SRC) Firmware	The function of the SRC firmware is to provide the executable programmatic script or program which can be run on the SRC hand-held device to undertake the required limited functions, with a high level of rigour and fidelity	8.3
DP Firmware	The function of the DP firmware is to provide the executable programmatic script or program which can be run on the DP's internal operating system to undertake the required DP functions	8.3.1

## 6 Technical requirements

### 6.1 Device Processor (DP) requirements

Each TVSL sign shall have a DP and it shall:

- a) conduct all processing associated with the communications support for paired slave sign(s)
- b) ensure that the requested speeds are displayed on the TVSL sign LED display and carries out all associated processing and monitoring functions
- c) monitor, log and report the operation of each connected sign display individually
- d) allow the TVSL sign to be controlled individually or as part of a pair
- e) be capable of storing up to 255 frames in its non-volatile memory. The full list of frame designations is captured in Appendix C - Full listing of speed limit frame designations
- f) command signs to display only the allowable frame combinations for that respective site as defined by the TGS
- g) allow local automatic reset of sign displays and the DP itself such as via watchdog(s)
- h) be capable of automatically dimming connected signs based on the average of the light sensor outputs. Automatic dimming of the sign occurs to increase luminance and hence conspicuity. The dimming levels and factory default settings are shown in Appendix A. Automatic dimming is not to be used for the purpose of extending battery life
- i) accept / reject valid or invalid commands made by the SRC, RSCS, configuration software or connected Master / Slave DPs
- j) allow a unique electronic identification for each DP to be configured
- k) electronically verify with the connected sign display that the displayed speed is consistent with the speed originally requested and permitted
- l) upon power up, ensure the sign LED display shall be initially blank and a valid frame is only displayed after all internal tests have passed, and
- m) accept an analogue input from a Local Facility Switch (LFS).

Additional information and functionality of the DP required is described in the following sections.

## **6.2 Permissible Frames (PF)**

Each TVSL sign DP shall be configured to store only those frames permitted to be displayed as defined in the approved TGS for the site in which they are operating (refer the list of frame designations in Appendix C). This will be achieved through the RSCS or configuration software referred to in this Technical Specification. The DP shall ensure that only permitted frame displays in the signs.

In addition to the other logged events detailed in Clause 9.1 below, the DP shall generate, log and report an alarm if a frame display request by the RSCS or SRC is for non-permitted frames.

The DP shall allow:

- a) the configuration and RSCS software to read and write its permitted frame (PF), and
- b) the display of stored frames only when requested by the SRC or RSCS.

This includes the default, maximum and minimum speeds allowed at the respective TVSL site.

Where TVSL signs are deployed in a pair, both TVSL sign displays shall only display the same permissible frame.

TVSL signs are not required to display lane closure symbols.

## **6.3 Frame display time**

The minimum display duration of each frame shall be configurable and accessible via the configuration software via the maintenance port. The time range and factory default settings are shown in Appendix A.

## **6.4 Flashing display control**

The DP shall command inner rings of the annulus to flash when speeds other than the site's default speed are displayed. The outermost ring shall remain on whilst the inner rings are flashing. Where two or more signs are connected to the same DP, the flashing elements of all signs at that site must flash in synchronisation. The flash rate and display cycle shall be configurable and factory default settings are shown in Appendix A.

## **6.5 Watchdog**

The TVSL sign display and DP must each monitor the state of its respective processor and blank the respective display(s) if processor failure occurs.

The DP shall generate an alarm and perform a graceful power shutdown all signs if the integrity of the firmware or configuration is compromised.

## **6.6 Global Positioning System (GPS)**

Each TVSL sign shall be fitted with a GPS receiver. The on-board GPS receiver shall monitor the location in three dimensions (Latitude, Longitude and Altitude) of each sign and also synchronise the TVSL DP internal clock. Each TVSL sign shall have provision for the numeric display to be synchronised by means of the sign's DP internal clock and the Master / Slave arrangement. The DP shall provide an alarm if a sign is moved beyond a 30 m radius of its installed position. This may be achieved using a virtual perimeter or "geo-fence".

### 6.7 Directional compass capability

Each TVSL sign may have the ability to discern the installed directional orientation (yaw) and whether any subsequent change in direction has been detected, through the use of a Magnetometer Inertial type sensor. The accuracy of the compass shall be at least  $\pm 1$  degree of yaw after calibration. An alarm shall be raised should the orientation be changed by  $\pm 20$  degrees from the installed position.

### 6.8 Turning motion sensor

Each TVSL sign may have the ability to discern whether the unit's position has been altered from the installed position through the use of gyroscope.

The GPS receiver, Directional Compass and Gyroscope facility will allow greater visibility of how the site layout is set out and whether any subsequent changes have occurred due to any number of scenarios. This type of technology is now commonplace within most modern mobile phone devices.

### 6.9 Short Range Controller (SRC)

The local method of control is via a hand-held SRC wireless communications device. The following requirements shall apply to the use of the SRC:

- a) Once TVSL signs have been configured for a particular construction site, they shall be capable of operating with the following modes only:
  - i. Mode 1 Work Mode – During Construction Hours Display
  - ii. Mode 2 No-Work Mode – After Construction Hours Display, and
  - iii. Mode 3 Blank Mode – Blank Display.
- b) Use “code hopping” or “rolling code” technology to prevent unauthorised use of the signs through methods such as “replay attacks”.
- c) Have a unique ID (refer to Clause 7.4 below) that is transmitted with each mode change request.
- d) The SRC shall have three programmable, and clearly labelled buttons to reflect the above modes, and be visually identified as shown in Table 6.9.

**Table 6.9 – SRC mode activation buttons**

SRC	Control mode	Button label text	Button selection 5 mm LED colour
Button 1	1	WORK	GREEN
Button 2	2	NO-WORK	AMBER
Button 3	3	BLANK	RED
Button 4	N/A	TRANSMIT	N/A

- e) When a SRC mode activation button is pressed and held for two seconds, then an LED indication within the button shall be illuminated to confirm to the Site Supervisor the desired mode of operation.

- f) If an SRC mode activation button LED is illuminated and the SRC Transmit Button is pressed and held for two seconds a control message shall be transmitted to the Master DP.
- g) Should a RSCS mode change request occur at the same time as the mode change request from an SRC, the SRC mode request shall have priority and the RSCS mode request shall be ignored (refer to Table 5.3 TVSL Control Methods).
- h) SRC batteries shall last for at least one year without requiring to be replaced.

To guard against accidental activation of a TVSL frame from the SRC, buttons must be pressed and held for two seconds before any TVSL speed frame will be changed.

- i) Where a Master and Slave DP pair has been configured, the SRC shall only communicate with the relevant Master.
- j) The DP may have the ability to deactivate a SRC from controlling the TVSL sign (e.g., due to lost or damaged SRCs) through the TVSL configuration software, RSCS software, and
- k) The physical buttons of the SRC are to be sufficiently spaced apart from each other so as not to prevent accidental incorrect activation.

#### **6.10 TVSL Sign Master / Slave pairing**

Where two signs are installed in a pair, one DP from the pair shall act as the Master controller for both signs and the other as the Slave. This shall be achieved through the setting a TVSL sign to operate either as a Master or Slave via the connected RSCS or configuration software described in Clauses 8.1 or 8.2 below respectively.

##### **6.10.1 Master**

Where a DP is set to operate in Master mode, all secure remote communications requests from a SRC or RSCS for a configured Master and Slave pair shall be accepted by this DP.

The DP shall be configured to simultaneously control up to a maximum of five slave DPs, each with the same control message including the unique slave DP ids.

##### **6.10.2 Slave**

Where a DP is set to operate in Slave mode, all remote communications from any SRC or RSCS for a configured Master and Slave pair shall be ignored.

#### **6.11 Local Facility Switch (LFS)**

Each TVSL sign shall have a physical Local Facility Switch (LFS) for onsite backup control. The LFS will allow the manual setting of the following modes:

1. **“BLANK Display” Mode:** Blank the TVSL Sign Display, allow maintenance port connections
2. **“Display 40” Mode:** Displays “40” on the respective TVSL Sign LED display panel
3. **“Display 60” Mode:** Displays “60” on the respective TVSL Sign LED display panel
4. **“Display 70” Mode:** Displays “70” on the respective TVSL Sign LED display panel
5. **“Display 80” Mode:** Displays “80” on the respective TVSL Sign LED display panel
6. **“Display 100” Mode:** Displays “100” on the respective TVSL Sign LED display panel

7. **“Display 110” Mode:** Displays “110” on the respective TVSL Sign LED display panel, and
8. **“REMOTE” Mode:** Sets the TVSL Sign to accept remote communications from SRC and RSCS.

Where selection on the LFS has been made, the DP shall wait for three seconds prior to activating the selected mode. This will ensure no other mode is inadvertently activated when physically toggling through the available options.

The DP shall allow configuration of each LFS selection such that only allowable display frames can be invoked per site.

The physical LFS switch shall be key-lockable to prevent vandalism and unauthorised control.

The purpose of a LFS is to provide manual local override to blank the sign display.

When a mode has been activated, the DP shall store the current GPS, compass bearing (if available) and inclination angle (if available). These values will represent the installed position for the purposes of the DP detecting and providing notification on any subsequent movement due to unauthorised tampering, vehicular incident, wind, accidents and other reasons.

#### 6.11.1 “BLANK Display” mode

Where BLANK mode is selected on an LFS, the following requirement shall apply:

- a) Whilst this mode is selected at the particular TVSL sign, any subsequent display requests from a RSCS Software session or SRC device(s) shall be ignored by the DP (applies to Master and Slave).
- b) If there is an established RSCS software session, monitoring and alarms from the Master DP shall still be transmitted to the RSCS Software.
- c) Critical alert SMS-based notifications shall still be transmitted by the DP (applies to Master and Slave).
- d) The TVSL sign shall remain powered up.
- e) Activate the dedicated maintenance port (the maintenance port is deactivated in all other LFS modes).
- f) Where two signs have been configured as a Master / Slave pair, selecting the LFS to “BLANK Display” on one TVSL sign shall NOT blank the other paired TVSL sign, and
- g) The LFS shall be designed as fail-safe operation and as such should it fail or be disconnected, “BLANK Display” mode will be activated.

Appendix B summarises the conditions at which the TVSL sign display is blanked.

#### 6.11.2 “Display 40” mode

Irrespective of whether Master / Slave designation, this mode will allow the speed limit of “40” to be continuously displayed on the respective Master or Slave TVSL sign. Only when the LFS mode selector is moved to another position will the sign display be changed.

### **6.11.3 “Display 60” mode**

Irrespective of whether Master / Slave designation, this mode will allow the speed limit of “60” to be continuously displayed on the respective Master or Slave TVSL sign. Only when the LFS mode selector is moved to another position will the sign display be changed.

### **6.11.4 “Display 70” mode**

Irrespective of whether Master / Slave designation, this mode will allow the speed limit of “70” to be continuously displayed on the respective Master or Slave TVSL sign. Only when the LFS mode selector is moved to another position will the sign display be changed.

### **6.11.5 “Display 80” mode**

Irrespective of whether Master / Slave designation, this mode will allow the speed limit of “80” to be continuously displayed on the respective Master or Slave TVSL sign. Only when the LFS mode selector is moved to another position will the sign display be changed.

### **6.11.6 “Display 100” mode**

Irrespective of whether Master / Slave designation, this mode will allow the speed limit of “100” to be continuously displayed on the respective Master or Slave TVSL sign. Only when the LFS mode selector is moved to another position will the sign display be changed.

### **6.11.7 “Display 110” mode**

Irrespective of whether Master / Slave designation, this mode will allow the speed limit of “110” to be continuously displayed on the respective Master or Slave TVSL sign. Only when the LFS mode selector is moved to another position will the sign display be changed.

### **6.11.8 “Remote” mode**

Where Remote mode is selected on the LFS, the following requirements apply:

- a) The Master DP shall accept control communications from a hand-held SRC device (s) only if the SRC device(s) are configured as being authorised to control the respective Master DP.
- b) The Master DP shall accept control communications from a PC / laptop running the RSCS software over a wireless or hardwired connection.
- c) The Slave DP shall accept control communications from a configured Master DP if it is configured as part of this Master and Slave TVSL pair.
- d) The Master DP shall transmit all messages associated with all monitoring and alarming categories under this specification.
- e) Critical alert SMS-based notifications shall be transmitted by the respective DP (Master and Slave).
- f) With the exception of Critical alert SMS-based notifications, where configured as part of a pair, all communications from a Slave DP shall be to its Master DP ONLY.

## **6.12 Maintenance communications port**

A separate dedicated maintenance communications port shall be provided at the TVSL Sign DP to allow a PC or laptop running the supplied TVSL sign configuration software to perform all maintenance and diagnostic functions on the respective TVSL sign.

The communications port shall be a dedicated 10/100Base-T Ethernet (RJ45) port.

If at any time during an existing maintenance port configuration session, an attempt is made to select an LFS mode other than the “Display Blank” mode, then the DP shall ignore the LFS request(s) and provide a visual notification to the maintenance operator such as a popup alarm(s) on the configuration software. The DP shall continue to ignore any LFS control mode change requests until such time, the existing maintenance port configuration session has been terminated.

Disconnection of the configuration software laptop from the maintenance port must not require further interaction from the user, nor in anyway interrupt operation or require rebooting of the DP.

Upon disconnection of the direct connection between the configuration laptop and the DP, the existing maintenance port configuration session shall be immediately terminated within the DP and “Blank Display” Mode re-initiated.

## 7 Communication requirements

### 7.1 General TVSL communications layout

Figure 7.1 – Local communication layout

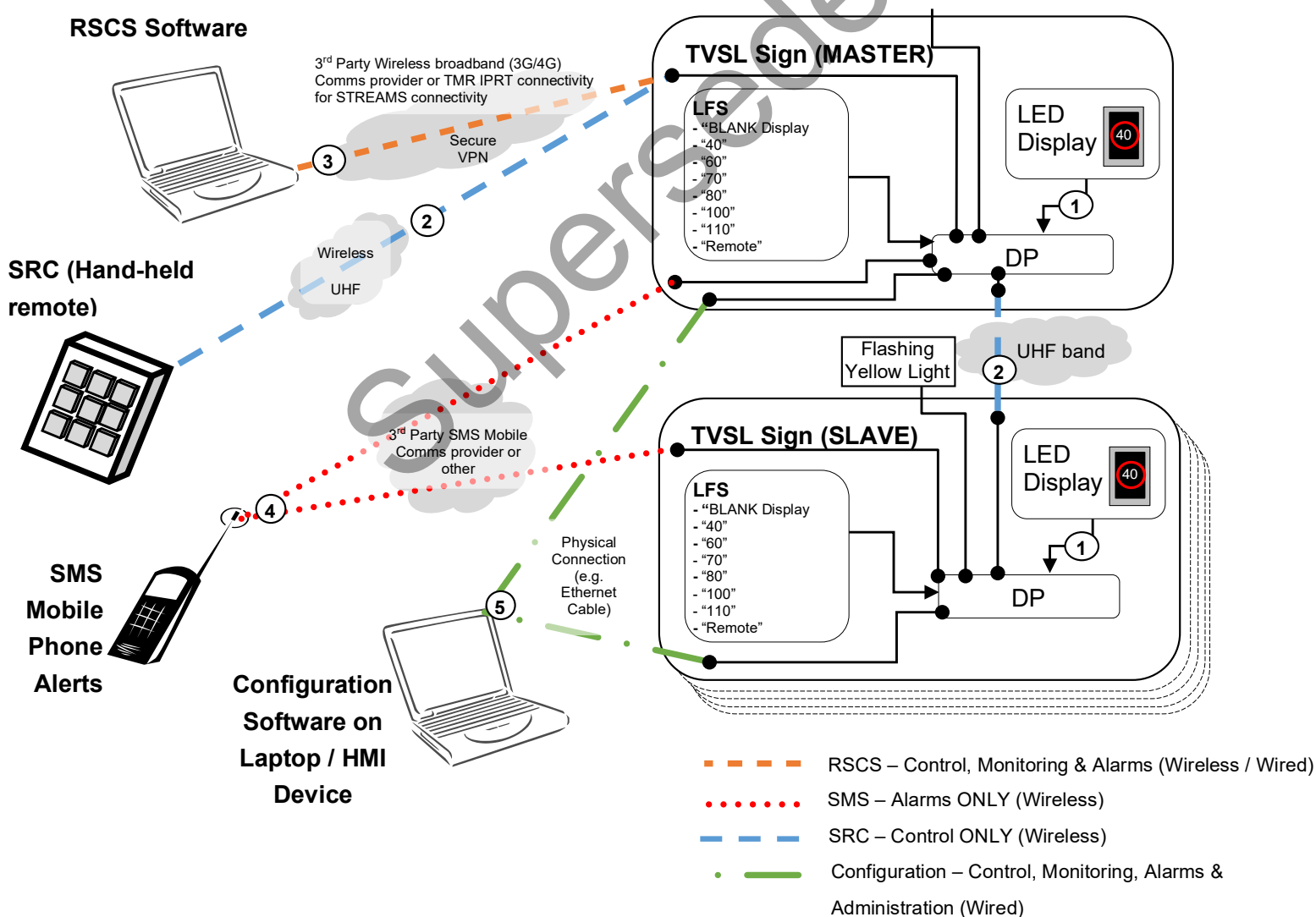

### 7.1.1 Device Processor (DP) and LED display (on the same trailer / concrete block)

The communications system shall be tamperproof and fully enclosed. Communication between the local DP and LED sign display shall be via a direct wired connection. The communications shall be encrypted. Messages transmitted between the DP and the LED display shall be completed within 50 ms of being sent. Refer to item 1 in Figure 7.1 above.

### 7.1.2 Master, Slave DP(s) and SRC(s)

Communication between the Master, Slave DP(s) and SRC(s) shall be via a local wireless communication technology, such as Ultra-High Frequency (UHF) radio band or other reliable wireless technology. Wireless communications shall also be encrypted. Refer to item 2 in Figure 7.1 above.

The SRC and Master DP shall communicate with 99.9% reliability over point-to-point ranges of greater than 30 m.

The Master and Slave DP(s) shall communicate with 99.9% reliability over point-to-point ranges of greater than 500 m. This will account for communications to multiple Slave DP(s)—some of which are separated from the Master DP at a maximum distance of 500 m at a site.

Where two TVSL signs are configured as a Master and Slave, periodic one-second communications (time-out period) polling messages shall be transmitted for the purposes of establishing whether a loss of communications has occurred. When loss of communications has been detected, an alert shall be raised on both signs.

Where a SRC has requested a change of speed on a TVLS sign DP, the speed change shall be completed within 250 ms of the request – i.e., the respective DP's display shall energise the requested frame LED pixels.

Any radio frequency communications antennas shall be positioned at the highest point on the TVSL sign to make effective use of available signal gain and avoid line of sight signal attenuation by objects such as concrete barriers and shrubs.

Communications shall be in accordance with Australian Communications and Media Authority (ACMA) requirements.

### 7.1.3 Configuration software and DP

Communications between the configuration software and the DP shall be over a direct 10/100base-T Ethernet connection. The communications cable shall be CAT5 and pre-terminated with EIA-568A RJ45 connectors. The IP address of the configuration laptop or other HMI device shall be able to be set to the same range of the DP's maintenance port network address. Refer to Table 7.1.3 below for example IP settings. Once an initial configuration connection has been established, the IP address settings shall be able to be changed from the defaults.

**Table 7.1.3 – Example DP and configuration laptop IP settings**

	DP maintenance Ethernet port settings	Configuration laptop or HMI device Ethernet port settings
IP address	192.168.1.100	192.168.1.101
Subnet mask	255.255.255.0	255.255.255.0
Default gateway	Not required	Not required

If an existing remote RSCS connection is currently in session when the LFS is changed to the “Blank Display” mode, the DP shall provide notification to the RSCS software logged on user that a local configuration connection is in session and any remote RSCS communication control requests will be ignored. After the local session has been disconnected and the LFS is returned to the “Remote” mode position, any remote session will be immediately re-established (only after an RSCS software confirmation dialog is raised to the RSCS operator for authorisation to proceed with the previously executed TGS plan and associated parameters), all data will be resynchronised between the connected DP (or pair) and RSCS software.

During an existing configuration maintenance port session, monitoring and alarms shall continue to be transmitted to the interrupted RSCS Software communications session. Refer to item 5 in Figure 7.1 above.

Direct connections are used to allow onsite maintenance and diagnostic functions to be carried out if required using TVSL configuration software through the maintenance port onsite at the Device Processor (DP) within the TVSL sign.

## **7.2 Remote site communications**

### **7.2.1 DP and RSCS**

There are essentially two remote site methods which can be used to allow communications between the DP and the RSCS.

#### **7.2.1.1 STREAMS as the RSCS**

The DP, if required by Transport and Main Roads, can be connected to STREAMS. The supplier of the DP shall ensure that it is fully compatible with the version of STREAMS at the time of delivery and submit a Transmax STREAMS Certificate of Support to Engineering and Technology section of Transport and Main Roads.

Network communications between the DP and STREAMS shall be in accordance with the requirements of MRTS245 *ITS Telecommunications Network (ITS TN)*.

#### **7.2.1.2 External systems as the RSCS**

Communication between the DP and a laptop or desktop computer running the RSCS software shall be 10/100Base-T Ethernet over a connection such as third party wireless 3G/4G mobile, ADSL or optical fibre. The carrier selected shall have sufficient and reliable coverage at the project site. Refer to item 3 in Figure 7.1 above.

The DP shall have a dedicated RJ45 10/100Base-T Ethernet port for the purposes of remote communications to the RSCS. This port will be used as the primary remote communications connection point for any wireless third-party modem, Ethernet switches or other devices required as per the remote communications design.

All messages transmitted from the RSCS software to the Master DP embedded firmware shall not exceed five seconds.

All messages transmitted from the Master DP to the RSCS software shall also not exceed five seconds.

Setup and ongoing provision of the mobile service required is the responsibility of the contractor who owns the TVSL sign.

All insecure protocols services, such as telnet, HTTP, etc., shall be able to be disabled on the DP to prevent any unauthorised communications terminal access to the local DP.

Should maintenance and diagnostic functions be required to be undertaken on the DP, then secure communication protocols such as SSH, HTTPS shall be supported.

Utilising a VPN will ensure that any communications over the internet is secure and unauthorised access is prevented.

All communication over third party communications network shall utilise a secure connection, such as a Virtual Private Network (VPN).

### **7.2.2 DP and critical alert SMS notification system**

Communication between the DP and a mobile phone for the purposes of the transmission of critical alert SMS notifications as defined in Clause 9.2 below shall be via a third-party SMS mobile service provider. The telecommunications carrier selected shall have sufficient and reliable coverage at the project site. Refer to item 4 in Figure 7.1 above.

### **7.3 Communications timeout**

For general operations of Master / Slave pair, if a slave does not receive an acknowledgement from the master within one second, the slave shall be blanked. If the Master does not receive an acknowledgement from the slave within one second of message transmission, then the slave shall be blanked (i.e., a blanking message will be transmitted to the slave). Refer to Appendix B for a summary of TVSL sign blanking conditions under this Technical Specification.

All timeout periods shall be software configurable with ranges and default values stated in Appendix A. This is required to allow a refinement of timeout periods to reflect current practices and scenarios.

For BLANK display mode, if configuration software session remains inactive for a period as defined in Appendix A, then the user session will be terminated and the user will need to re-logout and establish another session.

If the Master TVSL sign DP detects a loss of communications with the RSCS, then both the Master and Slave shall be blanked.

The DP must be capable of monitoring loss of communications with the RSCS and timeout after a specified period. When the Master DP LFS is in the 'REMOTE' mode, expiry of this time period must cause the DP to blank all physically connected signs (refer Appendix B). This period shall be a configurable parameter and is denoted 'Session timeout'. The range and factory default settings of session timeout are shown in Appendix A. The DP must also be capable of monitoring communications with the signs connected to it and timeout after a specified period when such communication is lost. Communications timeout check shall be performed periodically as shown in Appendix A. When the Master LFS is on any other mode, the session timeout check with the RSCS shall be ignored.

### **7.4 Communications identifiers**

The SRC, Master and Slave DPs shall each have a configurable unique communications ID.

Each Master and Slave pair combination may have a unique site pairing ID for the purposes of communication with the RSCS software.

Communications messages between the DPs (Master and Slave) and SRC shall include a checksum unique to each TVSL roadwork site that is based on the message information exchanged to ensure integrity of the communication is upheld.

The checksum shall be available for confirmation by the RSCS that the permitted frames at each TVSL site are the same as those stored within the RSCS software. The checksum shall be verified periodically and recomputed each time the permitted frames are changed and/or that the DP is reset/rebooted.

#### **7.4.1 Device Processor (DP) ID**

Each TVSL sign DP shall have a unique factory hardware ID which cannot be changed. This ID will be referenced by DPs of other TVSL signs, such as those in a Master / Slave pair arrangement.

Any communications messages transmitted by a DP shall embed the DP's respective ID.

A physical label displaying this ID must be clearly visible on the TVSL sign trailer / concrete block.

#### **7.4.2 SRC ID**

A unique SRC ID shall be configured on a SRC through an on-board settable dipswitch. This ID will be referenced by the Master TVSL DP.

### **8 Software requirements**

#### **8.1 Remote Sign Control System (RSCS) software**

The requirements defined in MRTS201 *General Equipment Requirements* apply to this Technical Specification. Additional requirements are provided under this Technical Specification are described below. The RSCS may be used on site or via a location which is remote to the roadwork site.

The RSCS, control and monitoring shall be hosted on an operating platform, such as Microsoft Windows®, which is industry standard at the time of application of this Technical Specification. Any software provided must be capable of operating on all such operating systems.

The software may be web-enabled and display the location of the managed TVSL signs on a GIS layer which has up-to-date maps and associated geographic or spatial information.

The software shall allow the default speed of a TVSL sign to be selected from a list. The software shall only allow the setting of speeds that are below or equal to the default speed – i.e., the current speed combo box type selection object will only be populated with permissible speed entries that are below the default speed for that TVSL sign or site.

The software shall allow for single Master / multiple Slave TVSL sign deployments that are required under a TGS to be fully controlled and monitored. Each traffic control direction TVSL deployment shall be completely separate to the opposite traffic control TVSL deployment. That is, for a bidirectional traffic flow, there shall be one SRC only for each direction, which controls only one arrangement of TVSL signs. Under no circumstances shall one SRC control both directions of traffic.

This software shall not permit any administration of the pre-programmed TVSL site deployment.

### 8.1.1 Software user interface and security

The RSCS, control and monitoring software user interface shall be such that user access is controlled through username and password logon credentials. The following types of user accounts shall be provisioned for in the RSCS software user interface:

- a) **Administrator:** For user access management and full access to all features of the TVSL RSCS, control and monitoring software user interfaces.

Note: For the purposes of site control of the TVSL signs only the Contractors' Site Supervisor is authorised to undertake such actions, and

- b) **Standard user:** For conducting general operating functions as defined by the Administrator account (clearing alarms, blanking the sign and other administrator authorised functions).

The factory default user credentials shall not be used and these shall be changed prior to any operation of the TVSL sign(s). Passwords shall be generally in accordance with IS18.

### 8.2 TVSL configuration / maintenance software (via direct connection)

The TVSL sign shall only be able to be programmed through the use of factory supplied configuration / maintenance software through a direct connection. The software shall be installed and run on laptop or other HMI device which is directly connected to the TVSL sign via the dedicated maintenance port. Prior to any configuration of a TVSL sign's DP, the respective LFS switch shall have the "Blank Display" mode selected.

The primary functions of this software shall be, but not limited to:

- a) Allowing the required initial setup of a TVSL sign (including, but not limited to, Master and Slave pairing configuration, configuration of PF, SRC administration functions such as removing lost SRC units and replacing with other SRC via SRC IDs).
- b) Perform any periodic maintenance and diagnostic functions required during the life of the product (including, but not limited to, reporting and extraction of fault / event logs, internal health statuses of internal TVSL sign components such as Battery, Solar Panel, other I/O statuses, connection states for Master / Slave, SRC / Master, RSCS / Master communications).
- c) Configured to request passwords as part of the signs controller access and configuration authorisation process.
- d) Able to present to the user a graphic image of the DP and the signs connected to it with icons or features that indicate whether there are any alarms or faults on any of the devices.
- e) Prompt the user to confirm a change to the DP's mode of operation.
- f) Capable of suggesting ranges for each parameter as applicable when programming and not allow these limits to be exceeded.
- g) Have a test program to facilitate testing of all the essential sign features, including ability to activate, deactivate all pixels and vary LED brightness. Capability to display and store on file a mimic of the sign showing defective LEDs is required, and
- h) The software must allow querying of events according to set criteria, such as by sign(s), time, date, event type or by duration.

### **8.3 Configuration management**

All software configuration changes shall be date and time stamp logged and included with the username of the software user who made the configuration setting change.

All firmware or software required for the TVSL sign, SRC or RSCS shall be fully backwards compatible.

All software associated with the use of TVSL shall allow the saving of existing configuration settings for backup.

The saved backup settings file shall be able to be used to restore previously saved configuration should this be required.

#### **8.3.1 Device Processor (DP) configuration**

All settings in the DP, including settings included in Appendix A and PF, shall be accessible using the configuration software.

The configuration shall be site-specific and must ensure that only the DP with the correct configuration for the respective TVSL site is allowed to control its respective TVSL site.

The site PF and other user configurable settings shall be stored in non-volatile memory.

Prior to the application of any software configuration change, a backup of the existing configuration shall be copied and stored in non-volatile memory.

## **9 TVSL sign monitoring, reporting and alarm requirements**

### **9.1 Sign monitoring and logs**

The DP shall monitor and log the following items in real-time as they occur:

- a) Log any SRC frame requests of the DP, including the unique identifier of the SRC requesting the speed change
- b) All RSCS software requests of the DP, including the RSCS username under which the request was made
- c) Loss of communications with the sign (noting the type of communication—for example, RSCS or Master / Slave)
- d) High internal sign enclosure temperature
- e) When the TVSL sign is set to blank and the blanking trigger description
- f) Report the GPS location of the sign from its installed position every 10 minutes
- g) Log an alarm when movement has been detected (GPS geo-fence, directional orientation and inclination angle)
- h) LED faults (LED pixel failures)
- i) Initialisation of TVSL (power up)
- j) When an SMS critical alert request has been transmitted by the DP
- k) Changed state of LFS (i.e., Blank Display, 40, 60, 80 and Remote modes)

- l) Low battery voltage (e.g., where the voltage of the power supply battery drops to a level that would prevent the battery from being recharged by the charging system)
- m) Loss of solar charge current / voltage
- n) Loss of load current
- o) Internal component faults (GPS and other modular hardware components), and
- p) All configuration changes shall include any user credentials associated with the change and respective ID (e.g., made through configuration or RSCS software).

The log shall identify the sign (through its respective sign ID) and its fault. The log shall include the date and time stamp for all entries and may be exported in a readily acceptable format, such as comma delimited text file (.csv), Microsoft Excel (.xls) or other formats as agreed with the project representative. Time shall be reported on the log file to centisecond (0.01s) accuracy or better.

The log shall also report the change of fault state. For example, when the fault condition has cleared and subsequently returns to normal operation.

The log file storage for the event log shall be sufficient to allow at least 12 months of continuous logging without overwriting. The log file storage shall be in the form of removable non-volatile memory module, such as an SD memory card. The oldest event record shall be overwritten first when the log file storage capacity has been exceeded.

For critical faults defined in Clause 9.3 below, the log shall include the RSCS or configuration software username ID which performed the acknowledgement and clearing of the fault.

Where a RSCS connection is in session, the RSCS software shall be synchronised and receive updates dynamically from the respective Master DP.

## **9.2 Alarms**

Each sign shall be fitted with:

- a) a yellow flashing light (refer to Clause 10.2.2) on top of the sign, and
- b) an SMS Mobile Phone Alert system (referred to in Clause 7.1 and 7.2)

Where critical faults occur:

- i. A yellow alert light (refer to Clause 10.2.2 below) on top of the sign shall flash until the fault is cleared through the RSCS or configuration software.
- ii. An SMS notification will be sent from the respective DP to pre-specified phone numbers with a clear description of the site, sign ID and a description of the fault.
- iii. If the sign is connected to the RSCS, an alarm shall also be generated on the user alarm monitoring interface.
- iv. The TVSL sign(s) display shall be blanked as shown in Appendix B.

### 9.3 Critical faults

Critical faults shall include the following.

- a) Movement of the sign after installation detected through:
  - i. Monitored GPS location of the TVSL sign exceeding the installed location Geo-fence 30 m perimeter, or
  - ii. Monitored Directional Compass position (if available) exceeds installed position by  $\pm 20$  degrees (yaw), or
  - iii. Monitored inclination (if available) exceeds installed position by  $\pm 5$  degrees (roll or pitch)
- b) LED pixel faults (refer to 12.6).
- c) Low battery voltage level alarm – when the battery level falls to the specified DoD (e.g., indicating insufficient charge or problem with charging circuit). At this stage, the sign shall perform a graceful shutdown in a controlled manner and as part of the shutdown process due to low power, the TVSL Sign flashing amber light shall be activated on each trailer.
- d) Charging Voltage too high – when the battery charge voltage exceeds the maximum charge voltage for the selected battery (e.g., indicating a possible battery charge regulator problem).
- e) If the DP has been requested to display a speed frame greater than what is permitted by the TGS for the TVSL site installation.
- f) Loss of solar module (e.g., open circuit detected on solar power charging circuit).
- g) Loss of load (e.g., possible disconnection of extension cable between trailer / concrete block and sign display.).
- h) Loss of communications – where a loss of communications occurs between the RSCS and the DP, then the RSCS software shall raise an alarm to the operator advising that the data displayed may no longer be valid as a result.

## 10 Mechanical and physical requirements

### 10.1 General

The mechanical and physical requirements defined in MRTS201 *General Equipment Requirements* apply to the TVSL sign displays and associated control electronics defined by this Technical Specification. The mounting structures supporting the TVSL sign and accessories shall be designed and RPEQ certified as appropriate for the site conditions in which they are intended to be used.

Each TVSL sign must be capable of being pole mounted on a trailer and/or concrete block support structure. The structure shall be designed in accordance with the TRUM Manual, Volume 3, Part 5: *Design Guide for Roadside Signs*, when installed with all supporting hardware and accessories used to operate the signs. Where the sign is solar powered, the support structure shall be RPEQ designed and certified to accommodate the required solar panels.

All compartments that contain any electronic components shall have an ingress protection rating IP56 in AS 60529. A certificate or letter of compliance from a NATA approved testing facility shall be made available to Transport and Main Roads upon request.

Trailer and/or concrete block support structure design documentation shall be submitted to the Principal's representative for acceptance 28 days prior to manufacture. **Hold Point 3**

The sign and DP must be constructed from durable materials to enable installation and reliable operations in the intended roadside and/or tunnel environment.

Unless otherwise specified, the design life of components must be as follows:

- a) LEDs / pixels: a minimum of five years
- b) other electrical systems: a minimum of 10 years
- c) sign enclosure: a minimum of 20 years, and
- d) structural supports: a minimum of 40 years.

## **10.2 Trailer**

Where the TVSL sign is mounted on a trailer, the sign and solar panel array shall have a mechanical system which allows the sign and solar panel to be safely secured to the trailer for transportation.

The mechanical system shall also allow for the sign and solar panel to be safely erected on site to ensure the sign is clearly visible to motorists and that the solar panels can be adjusted to ensure optimum solar exposure and maximum energy generation anywhere in Queensland.

The mechanical systems shall ensure that the sign cannot rotate due to wind gusts up to the ultimate wind speed the structure is designed.

The trailer shall comply with the applicable Australian Design Rules. The trailer shall be suitable for registration in accordance with the statutory requirements of the State of Queensland.

The TVSL sign trailer shall include a secure and robust mechanical assembly that will allow TVSL sign enclosure height adjustment and to allow for storage for transport.

### **10.2.1 Static speed limit sign**

Provision for a facility for a TC1568 static sign shall be provided on the TVSL sign trailer or concrete base. This is required in cases where the TVSL sign display has blanked for any reason, that a static sign speed as defined by the TGS will always be available.

To improve safety outcomes at road works, a static regulatory speed limit sign will be displayed to ensure motorists continue to obey the safe speed limit, in the event of the sign display failure.

The static sign may be inbuilt as an integral component of the TVSL mechanical assembly (trailer or concrete block mounted) or provided separately but co-located with the respective TVSL sign. The static sign shall be compliant with the requirements of the MUTCD.

### **10.2.2 Flashing Yellow Alert Light**

Each TVSL sign shall be fitted with a Flashing Yellow Light which complies with the following requirements:

- a) Securely mounted to the top centre of the TVSL sign rear surface
- b) utilises Yellow LED technology that complies with the Illumination and Chromaticity requirements of AS 5156

- c) flashes once every second, and
- d) light emitted by the flashing yellow light shall be obscured from view by oncoming traffic and only observable from the rear side of the TVSL sign.

### 10.2.3 Dimensions

The trailer dimensions shall take into consideration the sizes of the individual components required to be supported by the trailer. The dimensions shall be within the Queensland regulation limits as detailed below.

The trailer shall have a flat top and a minimum ground clearance equal to the height of the trailer wheel axle.

**Figure 10.2.3 – Trailer dimensions**

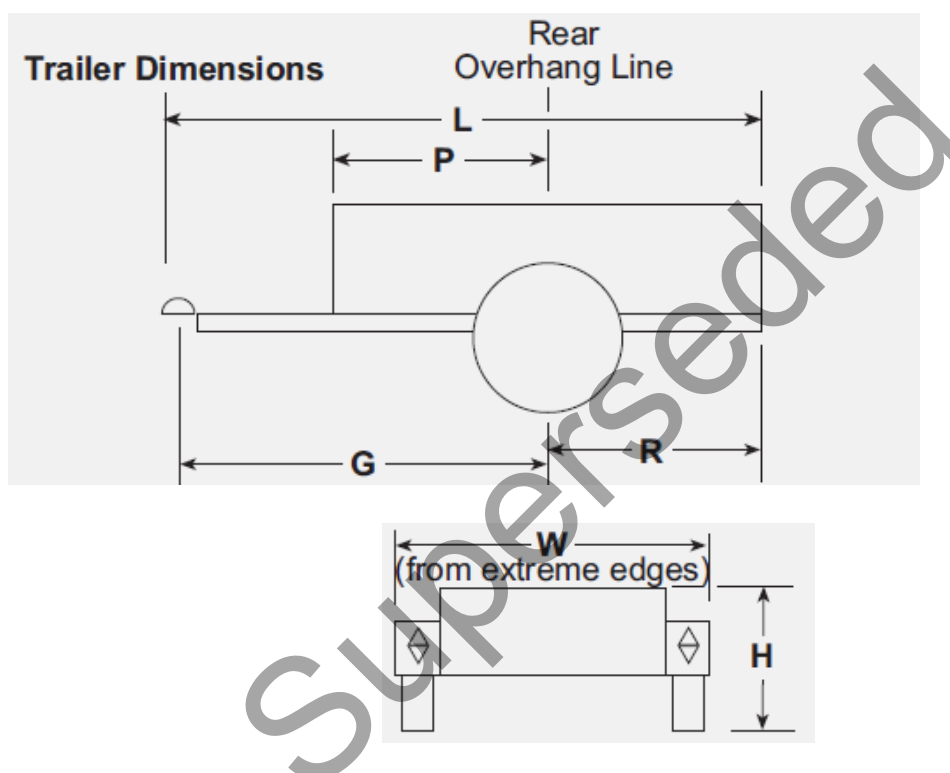

Referring to Figure 10.2.3 above, the trailer dimensions shall comply with the following:

Width (W) shall be 1.5 m or less

Height (H) shall be 2.4 m or less, and

Length (L) shall be 3 m or less.

The trailer shall be compliant with the following:

- *Transport Operations (Road Use Management) Act 1995*
- *Transport Operations (Road Use Management – Vehicle Standards and Safety) Regulation 2021*, and
- *Transport Operations (Road Use Management – Mass, Dimensions and Loading) Regulation 2005*

The trailer shall be positioned at least 0.5 m offset from the edge of the road.

#### **10.2.4 Wind loading**

All components of the TVSL sign shall be designed and certified by a suitably qualified RPEQ to ensure that it will maintain its intended orientation and position when subjected to the wind loading conditions of the region in which the TVSL is intended to be deployed, in accordance with AS/NZS 1170.2.

The weight of the trailer shall be reviewed in accordance with the relevant safety requirements to minimise roadside hazard for traffic.

#### **10.2.5 Storage compartment**

The storage compartment shall incorporate separate battery, hoist control and general storage compartments. In order to provide a high standard for occupational health and safety (OH&S), the compartments shall not protrude more than 30 mm above the trailer deck height. A minimum of one storage compartment for general use with a minimum of 0.1 m<sup>3</sup> capacity shall be provided.

All storage compartments shall be key lockable and comply with applicable OH&S regulations and requirements.

Any storage compartments shall have Ingress Protection (IP) rating of 56 in accordance with AS 60529.

#### **10.2.6 Stabilisers**

The trailer shall be suitably designed to ensure stability of the TVSL sign and associated hardware (i.e., solar panels) when positioned out on site. The type of stabilisers shall:

- a) allow for swivel
- b) be located on the four corners of the trailer, have fixed location on all four corners engineered to stabilise trailer and sign with sign fully extended while meeting wind loading conditions
- c) be wind-down and readily stowable for safe and secure towing
- d) have a load rating sufficient for levelling of the trailer, and
- e) have a locking mechanism with removable handles and secure drive nuts.

### **10.3 Sign enclosure**

The sign enclosure must house the sign displays and associated control electronics and comply with the relevant requirements of MRTS201 *General Equipment Requirements*.

#### **10.3.1 Sign enclosure dimensions**

The size of the speed limit display shall be as defined in AS 1744. The size of the TVSL sign shall be as specified in the contract. The enclosure shall be sufficiently sized for the size of the speed limit sign display.

The total external dimensions of the housing shall not be more than 150 mm larger than the required sign face.

The sign numeric displays must be based on a series of pixels forming a dot matrix display system. The horizontal and vertical pitch of the pixels in the matrix must be the same. The apparent width of all displayed elements including text must match the respective sign display defined in the Queensland MUTCD.

The TVSL LED sign display component must be fully self-contained and capable of being removed and installed on site by hand via the access door(s) for maintenance.

The display must be physically capable of displaying speeds from 40 km/hr up to the 110 km/hr for the TVSL site in 10 km/hr increments. The actual speed range for each site must be confirmed with the Principal during the commissioning activities and retained as part of the non-volatile information stored in the DP. Only those frames permitted to be displayed at the site of installation shall be programmed into the DP.

### **10.3.2 Doors**

Access doors and hatchways required for maintenance, configuration and stowage shall be secured via a key lock mechanism. All doors and hatchways shall prevent any moisture ingress into the compartments and have ingress protection rating of IP56.

### **10.3.3 Front cover**

A protective front cover must be fitted to the TVSL sign enclosure to form a viewing window. The front cover material must be a single, clear Lexan® sheet or equivalent, and have a non-reflective finish. The sheeting must be manufactured from sign-grade material SG300 with a thickness at least equal to that recommended by the manufacturer, with an absolute minimum of 4.5 mm. The viewing window must be such that when installed, the sides and bottom edges of the display face are fully visible at viewing angles of  $\pm 45^\circ$  (horizontal) and  $\pm 60^\circ$  (vertical) to the axis perpendicular to the front plane of the display.

The front cover must include a clear, non-reflective polycarbonate front screen. Suitable means must be provided to demist the front screen.

The front cover must be able to be removed for maintenance without requiring removal of internal components.

The front cover retention and seal design must allow for thermal expansion properties of the front cover material. The front cover surrounding framework and cover strips must provide the required weather proofing and strength for both positive and negative wind pressures and, where applicable, tunnel deluge systems.

The front covers shall be fastened to the sign display enclosure through security screws or other secure fastening methods.

In respect to the front viewing window, where installed, shall be made from anti-glare and U.V. stabilised polycarbonate with a minimum thickness of 4.5 mm.

### **10.3.4 Enclosure material and coatings**

The materials used for the trailer mounted TVSL enclosure shall be aluminium as specified in AS 5156, suitably reinforced and/or braced to facilitate the installation and continued operation of the unit in the intended application.

## **11 Electrical requirements**

### **11.1 Portable signs**

Portable signs shall be solar powered in accordance with the requirements of MRTS263 *Standalone Solar (PV) Power Systems* and the relevant requirements of AS 5156.

Each sign shall also have the facility to be mains powered so the batteries can be charged before being deployed to site or while at site. This shall include a mains battery charger and an IP65 rated locking connector to enable the external power supply to be easily connected and disconnected from the sign. The relevant electrical requirements defined in Clause 10 of MRTS201 *General Equipment Requirements* apply.

### **11.2 Fixed signs**

Fixed signs shall be mains powered, with an IP65 rated locking connector to enable the external power supply to be easily connected and disconnected from the sign, and with surge protection and battery power supply in accordance with the requirements of Clause 10 of MRTS201 *General Equipment Requirements* and the relevant requirements of AS 5156.

Where specified, lightning protection shall be provided to AS/NZS 1768.

### **11.3 Power system monitoring**

The power system log is used for discerning the proper operation of the power system. The DP shall log the electrical parameters (referred to in Clause 9) for each connected sign within the roadwork site. For solar charge current / voltage, load current and battery charge voltage, the DP will aggregate the measurements that it receives from the connected signs over a one hour period.

Each sign shall report no less than four measurements for each parameter per hour to the connected DP.

## **12 Sign display requirements**

### **12.1 Display technology**

The display technology must be light emitting diode (LED). To achieve the required sign luminance levels, the display pixels may be formed by arranging one or more LEDs in a cluster.

### **12.2 LED output**

Each individual LED must be driven with a continuous current with no peak and/or magnitudes exceeding 70% of the LED manufacturer's maximum continuous rating. For LEDs in a 5 mm or smaller diameter package, peak magnitudes of the LED current shall not exceed the manufactured rated driving current.

### **12.3 Character format**

The display of numerals for the purpose of speed regulation and information must comply as much as practicable with the fonts defined in MUTCD. Numerals must meet the fonts defined for use on a Regulatory Sign R4-1.

The annulus must not be less in size than that required for an equivalent static sign.

The minimum legibility (sight) distance and character height must be as indicated in the Table 12.3 below for both daytime and night-time viewing.

**Table 12.3 – Text and numeric display characteristics**

MUTCD VSL type	Regulatory sign size	Minimum sight distance (m)
Type A – Square	450 mm (h) x 450 mm (w)	100
A	R4-1A	100
B	R4-1B	200
C	R4-1C	300
D	R4-1D	400

Refer to traffic control drawings TC1785 1 and 2 for dimensions of the TVSL sign display.

Character heights are specified in standard signs R4-1 and vary according to whether two or three numerals are displayed.

#### **12.4 Display changes**

Display changes must be effected by blanking the display, and then activating all required pixels of the new frame simultaneously. Scrolling of images is not permitted.

All signs connected to a DP that are instructed to display the same frame must display that frame simultaneously. The sign shall prevent the concurrent display of two frames.

There must be no discernible flickering of the display. Background flickering as a result of checking the 'on' and 'off' pixel status must not be visible. The display must be able to be reproduced with all required active pixels by camera with shutter speed of up to 1/2000 s.

Upon displaying a new frame, the previously displayed frame shall be removed from the sign's memory.

#### **12.5 Display colour**

The display must be generated by red and white LEDs on a matte black background. The red and white colours must fall within the chromaticity coordinates specified in AS 5156.

#### **12.6 Default display**

Facilities must be included to detect failures within the display control system with the sign defaulting to pre-determined display when major faults are detected. The sign shall blank the display in the event of a sign processor fault. Time to blank shall be a configurable and the range and factory default settings are shown in Appendix A.

The sign display must monitor communications with the DP and blank the display if loss of communication experienced. The communications timeout period shall be configurable and the range and factory default settings are shown in Appendix A.

The sign shall be able to detect LED failure even if the LEDs may be required to be 'off' at the time of the periodic check. The display must be blanked upon failure of 2% of contiguous pixels for each displayed image or failure of more than 20% of LEDs.

Single LED failure, provided that the cumulative LED loss remains below the 2% and/or 20% thresholds described above or TVSL light sensor failure, should not result in blanking of the display.

Loss of power shall result in blanking of the display. On power restoration, the sign shall become available for activation and remain blank until commanded by the DP. At no time shall partial or incomplete frames be displayed.

### 12.7 Red annulus

The red annulus must consist of suitably constructed, evenly spaced pixel rings in accordance with Table 12.7 below. The number of rings to flash shall be counted from the inner ring. The outer ring(s) shall maintain an apparent solid ring to satisfy the regulatory status of the sign. When displaying the default speed limit, all pixel rings of the annulus must be illuminated.

The annulus shall be constructed so that LEDs connected in series are separated physically by at least three LEDs from other circuits.

**Table 12.7 – Red annulus display characteristics**

MUTCD VSL type	Minimum number of pixel rings (diameters)
Type A – Square	3
A	3
B	3
C	4
D	6

### 12.8 Flashing display elements

The sign shall allow selectable flashing of the whole and/or part of the display via all the communications ports. The flash rate parameters must be configurable and also be selectable via all of the communications ports as specified in Appendix A.

#### 12.8.1 Flashing partial annulus

The red annulus must be designed so that the inner rings of the annulus can be flashed as an independent event. In partial flash mode, between 50% and 75% of the total number of annulus pixel rings must flash. The inner diameter pixel ring(s) of the annulus must flash while the remaining outer ring(s) of the annulus must remain lit.

#### 12.8.2 Conspicuity devices

No conspicuity devices or lanterns are required. However, the sign shall allow conspicuity devices to be added in future if desired.

### 12.9 Optical performance

#### 12.9.1 Test procedures

The optical performance must be determined by measurement under laboratory conditions of the following parameters listed in Tables 12.3 and 12.9.3 below:

- a) minimum luminance ratio
- b) minimum and maximum luminance and luminous intensity uniformity
- c) viewing angle, and
- d) colour as per AS 5156.

The performance of the TVSL sign displays must meet or exceed the luminance and chromaticity parameters defined in AS 5156. **Witness Point 1**

### 12.9.2 Luminance

The luminance of the LEDs, when measured under laboratory conditions, must comply with the requirements of AS 5156.

### 12.9.3 Luminance intensity half angle

The luminance intensity half angle must comply with Table 12.9.3 below.

**Table 12.9.3 – Luminance intensity half angle**

MUTCD VLS type	Luminous intensity half angle (°)
A	15
B	15
C	6
D	6

### 12.9.4 Sun phantom

The effect of sunlight or other light sources shining on the optical elements must be controlled such that inactive pixels do not appear active.

## 13 Documentation requirements

The documentation requirements defined in MRTS201 *General Equipment Requirements* apply to this Technical Specification.

## 14 Testing, configuration and commissioning requirements

The testing, configuration and commissioning requirements defined in MRTS201 *General Equipment Requirements* apply to this Technical Specification.

## 15 Training requirements

The training requirements defined in MRTS201 *General Equipment Requirements* apply to this Technical Specification.

## 16 Maintenance requirements

The maintenance requirements defined in MRTS201 *General Equipment Requirements* apply to this Technical Specification.

## 17 Handover requirements

The handover requirements defined in MRTS201 *General Equipment Requirements* apply to this Technical Specification.

## 18 Type approval Checklist

The checklist for the type approval evaluation is published as Appendix D to this Technical Specification.

**Appendix A – Referenced variables and default settings**

Reference	Description	Range of values	Factory default	Device(s), systems affected
6.1	LED intensity control	1–16 levels	Dimming by DP	DP / sign
6.3	Frame display time	1–5 seconds	5 seconds	DP / sign
6.4 12.8	Flashing display elements	10–90% lit	1 s cycle time 60% lit (40% unlit)	DP / sign display
7.3	Local Configuration software – DP Communications Session Time-out	1–600 seconds	300 seconds	DP / Configuration Software
	RSCS – Master DP Communications Session Time-out	1–600 seconds	60 seconds	RCSC / Master DP
12.6	Communications check with sign display	0–30 seconds	Once every 5 seconds	DP / sign display
	Power recovery delay time	1–600 seconds	60 seconds	DP / sign display
	Minimum blank time	1–120 seconds	30 seconds	DP / sign display
	Sign processor fault blank time	0.5–3 seconds	1 second	sign display

**Appendix B – TVSL sign blanking conditions**

#	Relevant Clause	Blanking condition	TVSL sign blanked	
			Master	Slave
1	6.5	Master TVSL sign processor (DP) failure	Yes	Yes
2		Slave TVSL sign processor failure	No	Yes
3	6.11.1	LFS set to Blank Display Mode on Master TVSL	Yes	No
4		LFS set to Blank Display Mode on Slave TVSL	No	Yes
5		Master LFS goes faulty	Yes	Yes
6		Slave LFS goes faulty	No	Yes
7	7.3	Master TVSL sign loss of comms with Slave	No	Yes
8		Slave TVSL sign loss of comms with Master	No	Yes
9		RSCS Software loss of comms with Master TVSL	Yes	Yes
10	9.2	Master TVSL sign Critical faults	Yes	Yes
11		Slave TVSL sign Critical Faults	No	Yes
12	12.6	Master failure of 2% of contiguous pixels for displayed image or failure of more than 20% of LEDs	Yes	No
13		Slave failure of 2% of contiguous pixels for displayed image or failure of more than 20% of LEDs	No	Yes
14		When Master / Slave TVSL sign is restarted until commanded by the RSCS / SRC / Configuration or Maintenance Software	Yes	Yes

### Appendix C – Full listing of speed limit frame designations

Frame number	Description
41	40 km/h with flashing annulus
51	50 km/h with flashing annulus
60	60 km/h with fixed annulus
61	60 km/h with flashing annulus
70	70 km/h with fixed annulus
71	70 km/h with flashing annulus
80	80 km/h with fixed annulus
81	80 km/h with flashing annulus
90	90 km/h with fixed annulus
91	90 km/h with flashing annulus
100	100 km/h with fixed annulus
110	110 km/h with fixed annulus

At each site, only one frame shall be provided for each speed as follows:

- a) the frame for the 'default speed' shall be provided with a fixed annulus, and
- b) all other speeds lower than the default shall be provided with flashing annuli.

Example: The DP for a TVSL site on a motorway with a default speed of 80 km/h and minimum speed of 40 km/h shall be programmed with only frames 41, 51, 61, 71, 80.

**Appendix D – Type Approval Compliance Checklist**

Item#	MRTS260 Temporary Variable Speed Limit Signs	MRTS Clause	Verification Method					Compliance (Y, TBC, N, N/A)
			Visual Inspection	NATA Certification	Field OR Bench Test	Detailed Drawings	Other records (Datasheets, internal testing, RPEQ)	
<b>5 Functional requirements</b>								
1	The use of the TVSL signs shall be in accordance with Chapter 2 of the <i>Guideline – Traffic Management at Works on Roads</i> (and have the capability of operating as either: <ul style="list-style-type: none"> <li>• Single units as in Figure 5.1(a), or</li> <li>• a Master and Slave Pair as in Figure 5.1(b)</li> </ul> as defined by the approved Traffic Guidance Scheme (TGS).	5.1					X	
2	All TVSL system shall have a minimum of 99.9% system operating reliability.	5.2					X	
3	The TVSL shall be operated through the listed methods in the Table 5.3 below.	5.3					X	
4	Each component carries out specific functions associated with the operation of the TVSL sign and can be broadly categorised into hardware or software as shown in Figure 5.4 and described in Table 5.4.1.	5.4					X	
5	The software components associated with the TVSL sign shall typically be as described in Table 5.4.2.	5.4.2					X	

Item#	MRTS260 Temporary Variable Speed Limit Signs	MRTS Clause	Verification Method					Compliance (Y, TBC, N, N/A)
			Visual Inspection	NATA Certification	Field OR Bench Test	Detailed Drawings	Other records (Datasheets, internal testing, RPEQ)	
<b>6 Technical requirements</b>								
6	<p>Each TVSL sign shall have a Device Processor (DP) and it shall:</p> <ul style="list-style-type: none"> <li>a) conduct all processing associated with the communications support for paired slave sign(s)</li> <li>b) ensure that the requested speeds are displayed on the TVSL sign LED display and carries out all associated processing and monitoring functions</li> <li>c) monitor, log and report the operation of each connected sign display individually</li> <li>d) allow the TVSL sign to be controlled individually or as part of a pair</li> <li>e) be capable of storing up to 255 frames in its non-volatile memory. The full list of frame designations is captured in Appendix C</li> <li>f) command signs to display only the allowable frame combinations for that respective site as defined by the TGS</li> <li>g) allow local automatic reset of sign displays and the DP itself such as via watchdog(s)</li> <li>h) be capable of automatically dimming connected signs based on the average of the light sensor outputs. Automatic dimming of the sign occurs to increase luminance and hence conspicuity. The dimming levels and factory default settings are shown in Appendix A. Automatic dimming is not to be used for the purpose of extending battery life</li> <li>i) accept / reject valid or invalid commands made by the SRC, RSCS, configuration software or connected Master / Slave DPs</li> <li>j) allow a unique electronic identification for each DP to be configured</li> <li>k) electronically verify with the connected sign display that the displayed speed is consistent with the speed originally requested and permitted</li> <li>l) upon power up, ensure the sign LED display shall be initially blank and a valid frame is only displayed after all internal tests have passed, and</li> <li>m) accept an analogue input from a Local Facility Switch (LFS).</li> </ul>	6.1					X	

Item#	MRTS260 Temporary Variable Speed Limit Signs	MRTS Clause	Verification Method					Compliance (Y, TBC, N, N/A)
			Visual Inspection	NATA Certification	Field OR Bench Test	Detailed Drawings	Other records (Datasheets, internal testing, RPEQ)	
7	Each TVSL sign DP shall be configured to store only those frames permitted to be displayed as defined in the approved TGS for the site in which they are operating (refer the list of frame designations in Appendix C).	6.2					X	
8	This will be achieved through the RSCS or configuration software referred to in this Technical Specification.	6.2					X	
9	The DP shall ensure that only permitted frame displays in the signs.	6.2					X	
10	In addition to the other logged events detailed in Clause 9.1 below, the DP shall generate, log, and report an alarm if a frame display request by the RSCS or SRC is for non-permitted frames.	6.2					X	
11	The DP shall allow: a) the configuration and RSCS software to read and write its permitted frame (PF), and b) the display of stored frames only when requested by the SRC or RSCS.	6.2					X	
12	This includes the default, maximum and minimum speeds allowed at the respective TVSL site.	6.2					X	
13	Where TVSL signs are deployed in a pair, both TVSL sign displays shall only display the same permissible frame.	6.2					X	
14	TVSL signs are not required to display lane closure symbols.	6.2					X	
15	The minimum display duration of each frame shall be configurable and accessible via the configuration software via the maintenance port.	6.3					X	
16	The time range and factory default settings shall be as shown in Appendix A.	6.3					X	
17	The DP shall command inner rings of the annulus to flash when speeds other than the site's default speed are displayed.	6.4					X	
18	The outermost ring shall remain on whilst the inner rings are flashing.	6.4					X	

Item#	MRTS260 Temporary Variable Speed Limit Signs	MRTS Clause	Verification Method					Compliance (Y, TBC, N, N/A)
			Visual Inspection	NATA Certification	Field OR Bench Test	Detailed Drawings	Other records (Datasheets, internal testing, RPEQ)	
19	Where two or more signs are connected to the same DP, the flashing elements of all signs at that site must flash in synchronisation.	6.4					X	
20	The flash rate and display cycle shall be configurable and factory default settings are shown in Appendix A.	6.4						
21	The TVSL sign display and DP must each monitor the state of its respective processor and blank the respective display(s) if processor failure occurs.	6.5					X	
22	The DP shall generate an alarm and perform a graceful power shutdown all signs if the integrity of the firmware or configuration is compromised.	6.5					X	
23	Each TVSL sign shall be fitted with a GPS receiver.	6.6					X	
24	The on-board GPS receiver shall monitor the location in three dimensions (Latitude, Longitude and Altitude) of each sign and also synchronise the TVSL DP internal clock.	6.6					X	
25	Each TVSL sign shall have provision for the numeric display to be synchronised by means of the sign's DP internal clock and the Master / Slave arrangement.	6.6					X	
26	The DP shall provide an alarm if a sign is moved beyond a 30 m radius of its installed position. This may be achieved using a virtual perimeter or "geofence".	6.6			X		X	
27	Each TVSL sign may have the ability to discern the installed directional orientation (yaw) and whether any subsequent change in direction has been detected, through the use of a Magnetometer Inertial type sensor.	6.7					X	
28	The accuracy of the compass shall be at least – 1 degree of yaw after calibration.	6.7					X	
29	An alarm shall be raised should the orientation be changed by – 20 degrees from the installed position.	6.7			X		X	
30	Each TVSL sign may have the ability to discern whether the unit's position has been altered from the installed position through the use of gyroscope.	6.8					X	
31	The local method of control is via a hand-held Short-Range Controller (SRC) wireless communications device.	6.9	X				X	

Item#	MRTS260 Temporary Variable Speed Limit Signs	MRTS Clause	Verification Method					Compliance (Y, TBC, N, N/A)
			Visual Inspection	NATA Certification	Field OR Bench Test	Detailed Drawings	Other records (Datasheets, internal testing, RPEQ)	
32	The following requirements shall apply to the use of the SRC: a) Once TVSL signs have been configured for a particular construction site, they shall be capable of operating with the following modes only: i. Mode 1 Work Mode – During Construction Hours Display ii. Mode 2 No-Work Mode – After Construction Hours Display, and iii. Mode 3 Blank Mode – Blank Display.	6.9					X	
33	b) Use “code hopping” or “rolling code” technology to prevent unauthorised use of the signs through methods such as “replay attacks”.	6.9					X	
34	c) Have a unique ID (refer to Clause 7.4 below) that is transmitted with each mode change request.	6.9			X		X	
35	d) The SRC shall have three programmable, and clearly labelled buttons to reflect the above modes, and be visually identified as shown below.	6.9	X				X	
36	e) When a SRC mode activation button is pressed and held for two seconds, then an LED indication within the button shall be illuminated to confirm to the Site Supervisor the desired mode of operation.	6.9			X		X	
37	f) If an SRC mode activation button LED is illuminated and the SRC Transmit Button is pressed and held for two seconds a control message shall be transmitted to the Master DP.	6.9			X		X	
38	g) Should a RSCS mode change request occur at the same time as the mode change request from an SRC, the SRC mode request shall have priority and the RSCS mode request shall be ignored (refer to Table 5.3 TVSL Control Methods).	6.9			X		X	
39	h) SRC batteries shall last for at least one year without requiring to be replaced.	6.9						
40	i) Where a Master and Slave DP pair has been configured, the SRC shall only communicate with the relevant Master.	6.9			X		X	
41	j) The DP may have the ability to deactivate a SRC from controlling the TVSL sign (e.g., Due to lost or damaged SRCs) through the TVSL configuration software, RSCS software, and	6.9			X		X	

Item#	MRTS260 Temporary Variable Speed Limit Signs	MRTS Clause	Verification Method					Compliance (Y, TBC, N, N/A)
			Visual Inspection	NATA Certification	Field OR Bench Test	Detailed Drawings	Other records (Datasheets, internal testing, RPEQ)	
42	k) The physical buttons of the SRC are to be sufficiently spaced apart from each other so as not to prevent accidental incorrect activation.	6.9					X	
43	Where two signs are installed in a pair, one DP from the pair shall act as the Master controller for both signs and the other as the Slave.	6.10			X		X	
44	This shall be achieved through the setting a TVSL sign to operate either as a Master or Slave via the connected RSCS or configuration software described in Clauses 8.1 or 8.2 below respectively.	6.10						
45	Where a DP is set to operate in Master mode, all secure remote communications requests from a SRC or RSCS for a configured Master and Slave pair shall be accepted by this DP.	6.10.1					X	
46	The DP shall be configured to simultaneously control up to a maximum of five slave DPs, each with the same control message including the unique slave DP ids.	6.10.1			X		X	
47	Where a DP is set to operate in Slave mode, all remote communications from any SRC or RSCS for a configured Master and Slave pair shall be ignored.	6.10.2			X		X	
48	Each TVSL sign shall have a physical Local Facility Switch (LFS) for onsite backup control.	6.11	X				X	
49	The LFS will allow the manual setting of the following modes:	6.11			X		X	

Item#	MRTS260 Temporary Variable Speed Limit Signs	MRTS Clause	Verification Method					Compliance (Y, TBC, N, N/A)
			Visual Inspection	NATA Certification	Field OR Bench Test	Detailed Drawings	Other records (Datasheets, internal testing, RPEQ)	
50	1. "BLANK Display" Mode: Blank the TVSL Sign Display, allow maintenance port connections 2. "Display 40" Mode: Displays "40" on the respective TVSL Sign LED display panel 3. "Display 60" Mode: Displays "60" on the respective TVSL Sign LED display panel 4. "Display 70" Mode: Displays "70" on the respective TVSL Sign LED display panel 5. "Display 80" Mode: Displays "80" on the respective TVSL Sign LED display panel 6. "Display 100" Mode: Displays "100" on the respective TVSL Sign LED display panel 7. "Display 110" Mode: Displays "110" on the respective TVSL Sign LED display panel, and 8. "REMOTE" Mode: Sets the TVSL Sign to accept remote communications from SRC and RSCS.	6.11			X		X	
51	Where selection on the LFS has been made, the DP shall wait for three seconds prior to activating the selected mode. This will ensure no other mode is inadvertently activated when physically toggling through the available options.	6.11			X		X	
52	The DP shall allow configuration of each LFS selection such that only allowable display frames can be invoked per site.	6.11			X		X	
53	The physical LFS switch shall be key-lockable to prevent vandalism and unauthorised control.	6.11	X				X	
54	When a mode has been activated, the DP shall store the current GPS, compass bearing (if available) and inclination angle (if available).	6.11			X		X	
55	These values will represent the installed position for the purposes of the DP detecting and providing notification on any subsequent movement due to unauthorised tampering, vehicular incident, wind, accidents and other reasons.	6.11			X		X	

Item#	MRTS260 Temporary Variable Speed Limit Signs	MRTS Clause	Verification Method					Compliance (Y, TBC, N, N/A)
			Visual Inspection	NATA Certification	Field OR Bench Test	Detailed Drawings	Other records (Datasheets, internal testing, RPEQ)	
56	<p>"Where BLANK mode is selected on an LFS, the following requirement shall apply:</p> <p>a) Whilst this mode is selected at the particular TVSL sign, any subsequent display requests from a RSCS Software session or SRC device(s) shall be ignored by the DP (applies to Master and Slave)."</p> <p>b) If there is an established RSCS software session, monitoring and alarms from the Master DP shall still be transmitted to the RSCS Software.</p> <p>c) Critical alert SMS-based notifications shall still be transmitted by the DP (applies to Master and Slave).</p> <p>d) The TVSL sign shall remain powered up.</p> <p>e) Activate the dedicated maintenance port (the maintenance port is deactivated in all other LFS modes).</p> <p>f) Where two signs have been configured as a Master / Slave pair, selecting the LFS to "BLANK Display" on one TVSL sign shall NOT blank the other paired TVSL sign, and g) The LFS shall be designed as fail-safe operation and as such should it fail or be disconnected, "BLANK Display" mode will be activated.</p> <p>Appendix B summarises the conditions at which the TVSL sign display is blanked.</p>	6.11.1			X		X	
57	<p>Irrespective of whether Master / Slave designation, the "Display 40" mode will allow the speed limit of "40" to be continuously displayed on the respective Master or Slave TVSL sign. Only when the LFS mode selector is moved to another position will the sign display be changed.</p>	6.11.2			X		X	
58	<p>Irrespective of whether Master / Slave designation, the "Display 60" mode will allow the speed limit of "60" to be continuously displayed on the respective Master or Slave TVSL sign. Only when the LFS mode selector is moved to another position will the sign display be changed.</p>	6.11.3			X		X	

Item#	MRTS260 Temporary Variable Speed Limit Signs	MRTS Clause	Verification Method					Compliance (Y, TBC, N, N/A)
			Visual Inspection	NATA Certification	Field OR Bench Test	Detailed Drawings	Other records (Datasheets, internal testing, RPEQ)	
59	Irrespective of whether Master / Slave designation, the "Display 70" mode will allow the speed limit of "70" to be continuously displayed on the respective Master or Slave TVSL sign. Only when the LFS mode selector is moved to another position will the sign display be changed.	6.11.4			X		X	
60	Irrespective of whether Master / Slave designation, the "Display 80" mode will allow the speed limit of "80" to be continuously displayed on the respective Master or Slave TVSL sign. Only when the LFS mode selector is moved to another position will the sign display be changed.	6.11.5			X		X	
61	Irrespective of whether Master / Slave designation, the "Display 100" mode will allow the speed limit of "100" to be continuously displayed on the respective Master or Slave TVSL sign. Only when the LFS mode selector is moved to another position will the sign display be changed.	6.11.6			X		X	
62	Irrespective of whether Master / Slave designation, the "Display 110" mode will allow the speed limit of "110" to be continuously displayed on the respective Master or Slave TVSL sign. Only when the LFS mode selector is moved to another position will the sign display be changed.	6.11.7			X		X	

Item#	MRTS260 Temporary Variable Speed Limit Signs	MRTS Clause	Verification Method					Compliance (Y, TBC, N, N/A)
			Visual Inspection	NATA Certification	Field OR Bench Test	Detailed Drawings	Other records (Datasheets, internal testing, RPEQ)	
63	<p>"Where Remote mode is selected on the LFS, the following requirements apply:</p> <p>a) The Master DP shall accept control communications from a hand-held SRC device (s) only if the SRC device(s) are configured as being authorised to control the respective Master DP."</p> <p>b) The Master DP shall accept control communications from a PC / laptop running the RSCS software over a wireless or hardwired connection.</p> <p>c) The Slave DP shall accept control communications from a configured Master DP if it is configured as part of this Master and Slave TVSL pair.</p> <p>d) The Master DP shall transmit all messages associated with all monitoring and alarming categories under this specification.</p> <p>e) Critical alert SMS-based notifications shall be transmitted by the respective DP (Master and Slave).</p> <p>f) With the exception of Critical alert SMS-based notifications, where configured as part of a pair, all communications from a Slave DP shall be to its Master DP ONLY.</p>	6.11.8			X		X	
64	A separate dedicated maintenance communications port shall be provided at the TVSL Sign DP to allow a PC or laptop running the supplied TVSL sign configuration software to perform all maintenance and diagnostic functions on the respective TVSL sign.	6.12					X	
65	The communications port shall be a dedicated 10/100Base-T Ethernet (RJ45) port.	6.12					X	
66	If at any time during an existing maintenance port configuration session, an attempt is made to select an LFS mode other than the "Display Blank" mode, then the DP shall ignore the LFS request(s) and provide a visual notification to the maintenance operator such as a popup alarm(s) on the configuration software.	6.12			X		X	
67	The DP shall continue to ignore any LFS control mode change requests until such time, the existing maintenance port configuration session has been terminated.	6.12			X		X	

Item#	MRTS260 Temporary Variable Speed Limit Signs	MRTS Clause	Verification Method					Compliance (Y, TBC, N, N/A)
			Visual Inspection	NATA Certification	Field OR Bench Test	Detailed Drawings	Other records (Datasheets, internal testing, RPEQ)	
68	Disconnection of the configuration software laptop from the maintenance port must not require further interaction from the user, nor in anyway interrupt operation or require rebooting of the DP.	6.12			X		X	
69	Upon disconnection of the direct connection between the configuration laptop and the DP, the existing maintenance port configuration session shall be immediately terminated within the DP and "Blank Display" Mode re-initiated.	6.12			X		X	
<b>7 Communication requirements</b>								
70	The communications system shall be tamperproof and fully enclosed.	7.1.1	X				X	
71	Communication between the local DP and LED sign display shall be via a direct wired connection.	7.1.1					X	
72	The communications shall be encrypted.	7.1.1					X	
73	Messages transmitted between the DP and the LED display shall be completed within 50 ms of being sent. Refer to item 1 in Figure 7.1.	7.1.1					X	
74	Communication between the Master, Slave DP(s) and SRC(s) shall be via a local wireless communication technology, such as Ultra-High Frequency (UHF) radio band or other reliable wireless technology.	7.1.2					X	
75	Wireless communications shall also be encrypted. Refer to item 2 in Figure 7.1.	7.1.2					X	
76	The SRC and Master DP shall communicate with 99.9% reliability over point-to-point ranges of greater than 30 m.	7.1.2			X		X	
77	The Master and Slave DP(s) shall communicate with 99.9% reliability over point-to-point ranges of greater than 500 m. This will account for communications to multiple Slave DP(s)—some of which are separated from the Master DP at a maximum distance of 500 m at a site.	7.1.2			X		X	
78	Where two TVSL signs are configured as a Master and Slave, periodic one-second communications (time-out period) polling messages shall be transmitted for the purposes of establishing whether a loss of communications has occurred.	7.1.2					X	

Item#	MRTS260 Temporary Variable Speed Limit Signs	MRTS Clause	Verification Method					Compliance (Y, TBC, N, N/A)
			Visual Inspection	NATA Certification	Field OR Bench Test	Detailed Drawings	Other records (Datasheets, internal testing, RPEQ)	
79	When loss of communications has been detected, an alert shall be raised on both signs.	7.1.2			X		X	
80	Where a SRC has requested a change of speed on a TVLS sign DP, the speed change shall be completed within 250 ms of the request—i.e., the respective DP's display shall energise the requested frame LED pixels.	7.1.2					X	
81	Any radio frequency communications antennas shall be positioned at the highest point on the TVSL sign to make effective use of available signal gain and avoid line of sight signal attenuation by objects such as concrete barriers and shrubs.	7.1.2					X	
82	Communications shall be in accordance with Australian Communications and Media Authority (ACMA) requirements.	7.1.2					X	
83	Communications between the configuration software and the DP shall be over a direct 10/100base-T Ethernet connection.	7.1.3					X	
84	The communications cable shall be CAT5 and pre-terminated with EIA-568A RJ45 connectors.	7.1.3					X	
85	The IP address of the configuration laptop or other HMI device shall be able to be set to the same range of the DP's maintenance port network address. Refer to Table 7.1.3 for example IP settings.	7.1.3					X	
86	Once an initial configuration connection has been established, the IP address settings shall be able to be changed from the defaults.	7.1.3					X	
87	If an existing remote RSCS connection is currently in session when the LFS is changed to the "Blank Display" mode, the DP shall provide notification to the RSCS software logged on user that a local configuration connection is in session and any remote RCSC communication control requests will be ignored.	7.1.3			X		X	

Item#	MRTS260 Temporary Variable Speed Limit Signs	MRTS Clause	Verification Method					Compliance (Y, TBC, N, N/A)
			Visual Inspection	NATA Certification	Field OR Bench Test	Detailed Drawings	Other records (Datasheets, internal testing, RPEQ)	
88	After the local session has been disconnected and the LFS is returned to the "Remote" mode position, any remote session will be immediately re-established (only after an RSCS software confirmation dialog is raised to the RSCS operator for authorisation to proceed with the previously executed TGS plan and associated parameters), all data will be resynchronised between the connected DP (or pair) and RSCS software.	7.1.3						
89	During an existing configuration maintenance port session, monitoring and alarms shall continue to be transmitted to the interrupted RSCS Software communications session. Refer to item 5 in Figure 7.1.	7.1.3			X		X	
90	There are essentially two remote site methods which can be used to allow communications between the DP and the RSCS.	7.2.1						
91	The DP, if required by Transport and Main Roads, can be connected to STREAMS.	7.2.1.1					X	
92	The supplier of the DP shall ensure that it is fully compatible with the version of STREAMS at the time of delivery and submit a Transmax STREAMS Certificate of Support to Engineering and Technology section of Transport and Main Roads.	7.2.1.1					X	
93	Network communications between the DP and STREAMS shall be in accordance with the requirements of MRTS245 <i>ITS Telecommunications Network (ITS TN)</i> .	7.2.1.1					X	
94	Communication between the DP and a laptop or desktop computer running the RSCS software shall be 10/100 Base-T Ethernet over a connection such as third party wireless 3G/4G mobile, ADSL or optical fibre.	7.2.1.2					X	
95	The carrier selected shall have sufficient and reliable coverage at the project site. Refer to item 3 in Figure 7.1 (TVSL must be compatible with at least one carrier).	7.2.1.2					X	
96	The DP shall have a dedicated RJ45 10/100Base-T Ethernet port for the purposes of remote communications to the RSCS.	7.2.1.2					X	

Item#	MRTS260 Temporary Variable Speed Limit Signs	MRTS Clause	Verification Method					Compliance (Y, TBC, N, N/A)
			Visual Inspection	NATA Certification	Field OR Bench Test	Detailed Drawings	Other records (Datasheets, internal testing, RPEQ)	
97	This port will be used as the primary remote communications connection point for any wireless third-party modem, Ethernet switches or other devices required as per the remote communications design.	7.2.1.2					X	
98	All messages transmitted from the RSCS software to the Master DP embedded firmware shall not exceed five seconds.	7.2.1.2					X	
99	All messages transmitted from the Master DP to the RSCS software shall also not exceed five seconds.	7.2.1.2					X	
100	Setup and ongoing provision of the mobile service required is the responsibility of the contractor who owns the TVSL sign.	7.2.1.2						
101	All insecure protocols services, such as telnet, HTTP, etc., shall be able to be disabled on the DP to prevent any unauthorised communications terminal access to the local DP.	7.2.1.2					X	
102	Should maintenance and diagnostic functions be required to be undertaken on the DP, then secure communication protocols such as SSH, HTTPS shall be supported.	7.2.1.2					X	
103	Utilising a VPN will ensure that any communications over the internet is secure and unauthorised access is prevented.	7.2.1.2					X	
104	All communication over third party communications network shall utilise a secure connection, such as a Virtual Private Network (VPN).	7.2.1.2					X	
105	Communication between the DP and a mobile phone for the purposes of the transmission of critical alert SMS notifications as defined in Clause 9.2 below shall be via a third-party SMS mobile service provider with sufficient and reliable coverage.	7.2.2					X	
106	For general operations of Master / Slave pair, if a slave does not receive an acknowledgement from the master within one second, the slave shall be blanked. Refer to Appendix B.	7.3					X	

Item#	MRTS260 Temporary Variable Speed Limit Signs	MRTS Clause	Verification Method					Compliance (Y, TBC, N, N/A)
			Visual Inspection	NATA Certification	Field OR Bench Test	Detailed Drawings	Other records (Datasheets, internal testing, RPEQ)	
107	If the Master does not receive an acknowledgement from the slave within one second of message transmission, then the slave shall be blanked (i.e., a blanking message will be transmitted to the slave). Refer to Appendix B.	7.3					X	
108	All timeout periods shall be software configurable with ranges and default values stated in Appendix A. This is required to allow a refinement of timeout periods to reflect current practices and scenarios.	7.3						
109	For BLANK display mode, if configuration software session remains inactive for a period as defined in Appendix A, then the user session will be terminated, and the user will need to re-logout and establish another session.	7.3					X	
110	If the Master TVSL sign DP detects a loss of communications with the RSCS, then both the Master and Slave shall be blanked.	7.3					X	
111	The DP must be capable of monitoring loss of communications with the RSCS and timeout after a specified period.	7.3					X	
112	When the Master DP LFS is in the 'REMOTE' mode, expiry of this time must cause the DP to blank all physically connected signs (refer Appendix B).	7.3					X	
113	This period shall be a configurable parameter and is denoted 'Session timeout'.	7.3					X	
114	The range and factory default settings of session timeout is shown in Appendix A.	7.3						
115	The DP must also be capable of monitoring communications with the signs connected to it and timeout after a specified period when such communication is lost.	7.3					X	
116	Communications timeout check shall be performed periodically as shown in Appendix A.	7.3					X	
117	When the Master LFS is on any other mode, the session timeout check with the RSCS shall be ignored.	7.3					X	
118	The SRC, Master and Slave DPs shall each have a configurable unique communications ID.	7.4					X	

Item#	MRTS260 Temporary Variable Speed Limit Signs	MRTS Clause	Verification Method					Compliance (Y, TBC, N, N/A)
			Visual Inspection	NATA Certification	Field OR Bench Test	Detailed Drawings	Other records (Datasheets, internal testing, RPEQ)	
119	Each Master and Slave pair combination may have a unique site pairing ID for the purposes of communication with the RSCS software.	7.4					X	
120	Communications messages between the DPs (Master and Slave) and SRC shall include a checksum unique to each TVSL roadwork site that is based on the message information exchanged to ensure integrity of the communication is upheld.	7.4					X	
121	The checksum shall be available for confirmation by the RSCS that the permitted frames at each TVSL site are the same as those stored within the RSCS software.	7.4			X		X	
122	The checksum shall be verified periodically and recomputed each time the permitted frames are changed and/or that the DP is reset / rebooted.	7.4					X	
123	Each TVSL sign DP shall have a unique factory hardware ID which cannot be changed.	7.4.1					X	
124	This ID will be referenced by DPs of other TVSL signs, such as those in a Master / Slave pair arrangement.	7.4.1			X		X	
125	Any communications messages transmitted by a DP shall embed the DP's respective ID.	7.4.1			X		X	
126	A physical label displaying this ID must be clearly visible on the TVSL sign trailer / concrete block.	7.4.1	X				X	
127	A unique SRC ID shall be configured on a SRC through an on-board settable dipswitch. This ID will be referenced by the Master TVSL DP.	7.4.2					X	
<b>8 Software requirements</b>								
128	The software requirements defined in MRTS201 <i>General Equipment Requirements</i> apply to this Technical Specification.	8.1					X	
129	The RSCS may be used on site or via a location which is remote to the roadwork site.	8.1					X	
130	The RSCS, control and monitoring shall be hosted on an operating platform, such as Microsoft Windows®, which is industry standard at the time of application of this Technical Specification.	8.1					X	

Item#	MRTS260 Temporary Variable Speed Limit Signs	MRTS Clause	Verification Method					Compliance (Y, TBC, N, N/A)
			Visual Inspection	NATA Certification	Field OR Bench Test	Detailed Drawings	Other records (Datasheets, internal testing, RPEQ)	
131	Any software provided must be capable of operating on all such operating systems.	8.1					X	
132	The software may be web-enabled and display the location of the managed TVSL signs on a GIS layer which has up-to-date maps and associated geographic or spatial information.	8.1					X	
133	The software shall allow the default speed of a TVSL sign to be selected from a list.	8.1					X	
134	The software shall only allow the setting of speeds that are below or equal to the default speed – i.e., the current speed combo box type selection object will only be populated with permissible speed entries that are below the default speed for that TVSL sign or site.	8.1			X		X	
135	The software shall allow for single Master / multiple Slave TVSL sign deployments that are required under a TGS to be fully controlled and monitored.	8.1			X		X	
136	Each traffic control direction TVSL deployment shall be separate to the opposite traffic control TVSL deployment.	8.1			X		X	
137	That is, for a bidirectional traffic flow, there shall be one SRC only for each direction, which controls only one arrangement of TVSL signs.	8.1			X		X	
138	Under no circumstances shall one SRC control both directions of traffic.	8.1			X		X	
139	This software shall not permit any administration of the pre-programmed TVSL site deployment.	8.1			X		X	
140	The RSCS, control and monitoring software user interface shall be such that user access is controlled through username and password logon credentials.	8.1.1			X		X	

Item#	MRTS260 Temporary Variable Speed Limit Signs	MRTS Clause	Verification Method					Compliance (Y, TBC, N, N/A)
			Visual Inspection	NATA Certification	Field OR Bench Test	Detailed Drawings	Other records (Datasheets, internal testing, RPEQ)	
141	The following types of user accounts shall be provisioned for in the RSCS software user interface: a) <b>Administrator</b> : For user access management and full access to all features of the TVSL RSCS, control and monitoring software user interfaces. Note: For the purposes of site control of the TVSL signs only the Contractors' Site Supervisor is authorised to undertake such actions, and b) <b>Standard user</b> : For conducting general operating functions as defined by the Administrator account (clearing alarms, blanking the sign and other administrator authorised functions).	8.1.1			X		X	
142	The factory default user credentials shall not be used, and these shall be changed prior to any operation of the TVSL sign(s).	8.1.1			X		X	
143	Passwords shall be generally in accordance with IS18.	8.1.1			X		X	
144	The TVSL sign shall only be able to be programmed using factory supplied configuration / maintenance software through a direct connection.	8.2			X		X	
145	The software shall be installed and run-on laptop or other HMI device which is directly connected to the TVSL sign via the dedicated maintenance port.	8.2			X		X	
146	Prior to any configuration of a TVSL sign's DP, the respective LFS switch shall have the "Blank Display" mode selected.	8.2			X		X	

Item#	MRTS260 Temporary Variable Speed Limit Signs	MRTS Clause	Verification Method					Compliance (Y, TBC, N, N/A)
			Visual Inspection	NATA Certification	Field OR Bench Test	Detailed Drawings	Other records (Datasheets, internal testing, RPEQ)	
147	<p>"The primary functions of TVSL configuration / maintenance software shall be, but not limited to:</p> <p>a) Allowing the required initial setup of a TVSL sign (including, but not limited to, Master and Slave pairing configuration, configuration of PF, SRC administration functions such as removing lost SRC units and replacing with other SRC via SRC IDs)."</p> <p>b) Perform any periodic maintenance and diagnostic functions required during the life of the product (including, but not limited to, reporting and extraction of fault / event logs, internal health statuses of internal TVSL sign components such as Battery, Solar Panel, other I/O statuses, connection states for Master / Slave, SRC / Master, RSCS / Master communications).</p> <p>c) Configured to request passwords as part of the signs controller access and configuration authorisation process.</p> <p>d) Able to present to the user a graphic image of the DP and the signs connected to it with icons or features that indicate whether there are any alarms or faults on any of the devices.</p> <p>e) Prompt the user to confirm a change to the DP's mode of operation.</p> <p>f) Capable of suggesting ranges for each parameter as applicable when programming and not allow these limits to be exceeded.</p> <p>g) Have a test program to facilitate testing of all the essential sign features, including ability to activate, deactivate all pixels and vary LED brightness. Capability to display and store on file a mimic of the sign showing defective LEDs is required,</p> <p>h) The software must allow querying of events according to set criteria, such as by sign(s), time, date, event type or by duration.</p>	8.2			X		X	
148	All software configuration changes shall be date and time stamp logged and included with the username of the software user who made the configuration setting change.	8.3			X		X	

Item#	MRTS260 Temporary Variable Speed Limit Signs	MRTS Clause	Verification Method					Compliance (Y, TBC, N, N/A)
			Visual Inspection	NATA Certification	Field OR Bench Test	Detailed Drawings	Other records (Datasheets, internal testing, RPEQ)	
149	All firmware or software required for the TVSL sign, SRC or RSCS shall be fully backwards compatible.	8.3			X		X	
150	All software associated with the use of TVSL shall allow the saving of existing configuration settings for backup.	8.3			X		X	
151	The saved backup settings file shall be able to be used to restore previously saved configuration should this be required.	8.3			X		X	
152	All settings in the DP, including settings included in Appendix A and PF, shall be accessible using the configuration software.	8.3.1			X		X	
153	The configuration shall be site-specific and must ensure that only the DP with the correct configuration for the respective TVSL site is allowed to control its respective TVSL site.	8.3.1			X		X	
154	The site PF and other user configurable settings shall be stored in non-volatile memory.	8.3.1					X	
155	Prior to the application of any software configuration change, a backup of the existing configuration shall be copied and stored in non-volatile memory.	8.3.1			X		X	
<b>9 TVSL sign monitoring, reporting and alarm requirements</b>								
156	The DP shall monitor and log the following items in real-time as they occur: a) Log any SRC frame requests of the DP, including the unique identifier of the SRC requesting the speed change.	9.1			X		X	
157	b) All RSCS software requests of the DP, including the RSCS username under which the request was made.	9.1			X		X	
158	c) Loss of communications with the sign (noting the type of communication—for example, RSCS or Master / Slave).	9.1			X		X	
159	d) High internal sign enclosure temperature.	9.1			X		X	
160	e) When the TVSL sign is set to blank and the blanking trigger description.	9.1			X		X	
161	f) Report the GPS location of the sign from its installed position every 10 minutes.	9.1			X		X	

Item#	MRTS260 Temporary Variable Speed Limit Signs	MRTS Clause	Verification Method					Compliance (Y, TBC, N, N/A)
			Visual Inspection	NATA Certification	Field OR Bench Test	Detailed Drawings	Other records (Datasheets, internal testing, RPEQ)	
162	g) Log an alarm when movement has been detected (GPS geo-fence, directional orientation and inclination angle).	9.1			X		X	
163	h) LED faults (LED pixel failures).	9.1			X		X	
164	i) Initialisation of TVSL (power up).	9.1			X		X	
165	j) When an SMS critical alert request has been transmitted by the DP.	9.1			X		X	
166	k) Changed state of LFS (i.e., Blank Display, 40, 60, 80 and Remote modes).	9.1			X		X	
167	l) Low battery voltage (e.g., Where the voltage of the power supply battery drops to a level that would prevent the battery from being recharged by the charging system).	9.1			X		X	
168	m) Loss of solar charge current / voltage.	9.1			X		X	
169	n) Loss of load current.	9.1			X		X	
170	o) Internal component faults (GPS and other modular hardware components), and	9.1			X		X	
171	p) All configuration changes shall include any user credentials associated with the change and respective ID (e.g., made through configuration or RSCS software).	9.1			X		X	
172	The log shall identify the sign (through its respective sign ID) and its fault.	9.1			X		X	
173	The log shall include the date and time stamp for all entries and may be exported in a readily acceptable format, such as comma delimited text file (.csv), Microsoft Excel (.xls) or other formats as agreed with the project representative.	9.1			X		X	
174	Time shall be reported on the log file to centisecond (0.01 s) accuracy or better.	9.1					X	
175	The log shall also report the change of fault state. For example, when the fault condition has cleared and subsequently returns to normal operation.	9.1					X	
176	The log file storage for the event log shall be sufficient to allow at least 12 months of continuous logging without overwriting.	9.1					X	

Item#	MRTS260 Temporary Variable Speed Limit Signs	MRTS Clause	Verification Method					Compliance (Y, TBC, N, N/A)
			Visual Inspection	NATA Certification	Field OR Bench Test	Detailed Drawings	Other records (Datasheets, internal testing, RPEQ)	
177	The log file storage shall be in the form of removable non-volatile memory module, such as an SD memory card.	9.1					X	
178	The oldest event record shall be overwritten first when the log file storage capacity has been exceeded.	9.1					X	
179	For critical faults defined in Clause 9.3 below, the log shall include the RSCS or configuration software username ID which performed the acknowledgement and clearing of the fault.	9.1					X	
180	Where a RSCS connection is in session, the RSCS software shall be synchronised and receive updates dynamically from the respective Master DP.	9.1					X	
181	Each sign shall be fitted with: a) a yellow flashing light (refer to Clause 10.2.2) on top of the sign, and b) an SMS Mobile Phone Alert system (referred to in Clause 7.1 and 7.2)	9.2					X	
182	Where critical faults occur (SEE 186 BELOW): i. A yellow alert light (refer to Clause 10.2.2 below) on top of the sign shall flash until the fault is cleared through the RSCS or configuration software	9.2			X		X	
183	ii. An SMS notification will be sent from the respective DP to pre-specified phone numbers with a clear description of the site, sign ID and a description of the fault.	9.2			X		X	
184	iii. If the sign is connected to the RSCS, an alarm shall also be generated on the user alarm monitoring interface.	9.2			X		X	
185	iv. The TVSL sign(s) display shall be blanked as shown in Appendix B.	9.2			X		X	

Item#	MRTS260 Temporary Variable Speed Limit Signs	MRTS Clause	Verification Method					Compliance (Y, TBC, N, N/A)
			Visual Inspection	NATA Certification	Field OR Bench Test	Detailed Drawings	Other records (Datasheets, internal testing, RPEQ)	
186	<p>Critical faults shall include the following:</p> <p>a) Movement of the sign after installation detected through:</p> <ul style="list-style-type: none"> <li>i. Monitored GPS location of the TVSL sign exceeding the installed location Geo-fence 30 m perimeter, or</li> <li>ii. Monitored Directional Compass position (if available) exceeds installed position by <math>\pm 20</math> degrees (yaw), or</li> <li>iii. Monitored inclination (if available) exceeds installed position by <math>\pm 5</math> degrees (roll or pitch)</li> </ul> <p>b) LED pixel faults (refer to Clause 12.6)."</p> <p>c) Low battery voltage level alarm – when the battery level falls to the specified DoD (e.g., indicating insufficient charge or problem with charging circuit). At this stage, the sign shall perform a graceful shutdown down in a controlled manner and as part of the shutdown process due to low power, the TVSL Sign flashing amber light shall be activated on each trailer.</p> <p>d) Charging Voltage too high – when the battery charge voltage exceeds the maximum charge voltage for the selected battery (e.g., indicating a possible battery charge regulator problem).</p> <p>e) If the DP has been requested to display a speed frame greater than what is permitted by the TGS for the TVSL site installation.</p> <p>f) Loss of solar module (e.g., open circuit detected on solar power charging circuit).</p> <p>g) Loss of load (e.g., possible disconnection of extension cable between trailer / concrete block and sign display.</p> <p>h) Loss of communications – where a loss of communications occurs between the RSCS and the DP, then the RSCS software shall raise an alarm to the operator advising that the data displayed may no longer be valid as a result.</p>	9.3						

Item#	MRTS260 Temporary Variable Speed Limit Signs	MRTS Clause	Verification Method					Compliance (Y, TBC, N, N/A)
			Visual Inspection	NATA Certification	Field OR Bench Test	Detailed Drawings	Other records (Datasheets, internal testing, RPEQ)	
<b>10 Mechanical and physical requirements</b>								
187	The mechanical and physical requirements defined in MRTS201 <i>General Equipment Requirements</i> apply to the TVSL sign displays and associated control electronics defined by this Technical Specification.	10.1					X	
188	The mounting structures supporting the TVSL sign and accessories shall be designed and RPEQ certified as appropriate for the site conditions in which they are intended to be used.	10.1					X	
189	Each TVSL sign must be capable of being pole mounted on a trailer and/or concrete block support structure.	10.1					X	
190	The structure shall be designed in accordance with the TRUM Manual, Volume 3, Part 5: Design Guide for Roadside Signs, when installed with all supporting hardware and accessories used to operate the signs.	10.1					X	
191	Where the sign is solar powered, the support structure shall be RPEQ designed and certified to accommodate the required solar panels.	10.1					X	
192	All compartments that contain any electronic components shall have an ingress protection rating IP56 in AS 60529.	10.1		X				
193	A certificate or letter of compliance from a NATA approved testing facility shall be made available to Transport and Main Roads upon request.	10.1		X				
194	Trailer and/or concrete block support structure design documentation shall be submitted to the principal's representative for acceptance 28 days prior to manufacture.	10.1					X	
195	The sign and DP must be constructed from durable materials to enable installation and reliable operations in the intended roadside and/or tunnel environment.	10.1					X	

Item#	MRTS260 Temporary Variable Speed Limit Signs	MRTS Clause	Verification Method					Compliance (Y, TBC, N, N/A)
			Visual Inspection	NATA Certification	Field OR Bench Test	Detailed Drawings	Other records (Datasheets, internal testing, RPEQ)	
196	Unless otherwise specified, the design life of components must be as follows: a) LEDs / pixels: a minimum of five years b) other electrical systems: a minimum of 10 years c) sign enclosure: a minimum of 20 years d) structural supports: a minimum of 40 years.	10.1					X	
197	Where the TVSL sign is mounted on a trailer, the sign and solar panel array shall have a mechanical system which allows the sign and solar panel to be safely secured to the trailer for transportation.	10.2					X	
198	The mechanical system shall also allow for the sign and solar panel to be safely erected on site to ensure the sign is clearly visible to motorists and that the solar panels can be adjusted to ensure optimum solar exposure and maximum energy generation anywhere in Queensland.	10.2					X	
199	The mechanical systems shall ensure that the sign cannot rotate due to wind gusts up to the ultimate wind speed the structure is designed.	10.2					X	
200	The trailer shall comply with the applicable Australian Design Rules.	10.2					X	
201	The trailer shall be suitable for registration in accordance with the statutory requirements of the State of Queensland.	10.2					X	
202	The TVSL sign trailer shall include a secure and robust mechanical assembly that will allow TVSL sign enclosure height adjustment and to allow for storage for transport.	10.2					X	
203	Provision for a facility for a TC1568 static sign shall be provided on the TVSL sign trailer or concrete base. This is required in cases where the TVSL sign display has blanked for any reason, that a static sign speed as defined by the TGS will always be available.	10.2					X	
204	The static sign may be inbuilt as an integral component of the TVSL mechanical assembly (trailer or concrete block mounted) or provided separately but co-located with the respective TVSL sign.	10.2					X	
205	The static sign shall be compliant with the requirements of the MUTCD.	10.2					X	

Item#	MRTS260 Temporary Variable Speed Limit Signs	MRTS Clause	Verification Method					Compliance (Y, TBC, N, N/A)
			Visual Inspection	NATA Certification	Field OR Bench Test	Detailed Drawings	Other records (Datasheets, internal testing, RPEQ)	
206	Each TVSL sign shall be fitted with a Flashing Yellow Light which complies with the following requirements: a) Securely mounted to the top centre of the TVSL sign rear surface b) utilises Yellow LED technology that complies with the Illumination and Chromaticity requirements of AS 5156 c) flashes once every second, and d) light emitted by the flashing yellow light shall be obscured from view by oncoming traffic and only observable from the rear side of the TVSL sign.	10.2.2		X			X	
207	The trailer dimensions shall take into consideration the sizes of the individual components required to be supported by the trailer.	10.2.3					X	
208	The dimensions shall be within the Queensland regulation limits as detailed below.	10.2.3					X	
209	The trailer shall have a flat top and a minimum ground clearance equal to the height of the trailer wheel axle.	10.2.3					X	
210	Referring to Figure 10.2.3 above, the trailer dimensions shall comply with the following: • Width (W) shall be 1.5 m or less • Height (H) shall be 2.4 m or less, and • Length (L) shall be 3 m or less.	10.2.3					X	
211	The trailer shall be compliant with the following: <i>Transport Operations (Road Use Management) Act 1995</i> <i>Transport Operations (Road Use Management – Vehicle Standards and Safety) Regulation 2021</i> , and <i>Transport Operations (Road Use Management – Mass, Dimensions and Loading) Regulation 2005</i> The trailer shall be positioned at least 0.5 m offset from the edge of the road.	10.2.3					X	

Item#	MRTS260 Temporary Variable Speed Limit Signs	MRTS Clause	Verification Method					Compliance (Y, TBC, N, N/A)
			Visual Inspection	NATA Certification	Field OR Bench Test	Detailed Drawings	Other records (Datasheets, internal testing, RPEQ)	
212	All components of the TVSL sign shall be designed and certified by a suitably qualified RPEQ to ensure that it will maintain its intended orientation and position when subjected to the wind loading conditions of the region in which the TVSL is intended to be deployed, in accordance with AS/NZS 1170.2.	10.2.4					X	
213	The weight of the trailer shall be reviewed in accordance with the relevant safety requirements to minimise roadside hazard for traffic.	10.2.4					X	
214	The storage compartment shall incorporate separate battery, hoist control and general storage compartments.	10.2.5					X	
215	To provide a high standard for occupational health and safety (OH&S), the compartments shall not protrude more than 30 mm above the trailer deck height.	10.2.5					X	
216	A minimum of one storage compartment for general use with a minimum of 0.1 m <sup>3</sup> capacity shall be provided.	10.2.5					X	
217	All storage compartments shall be key lockable and comply with applicable OH&S regulations and requirements.	10.2.5					X	
218	Any storage compartments shall have Ingress Protection (IP) rating of 56 in accordance with AS 60529.	10.2.5		X				
219	The trailer shall be suitably designed to ensure stability of the TVSL sign and associated hardware (i.e., solar panels) when positioned out on site.	10.2.6					X	
220	The type of stabilisers shall: a) allow for swivel b) be located on the four corners of the trailer, have fixed location on all four corners engineered to stabilise trailer and sign with sign fully extended while meeting wind loading conditions c) be wind-down and readily stowable for safe and secure towing, and d) have a load rating sufficient for levelling of the trailer, and e) have a locking mechanism with removable handles and secure drive nuts.	10.2.6					X	

Item#	MRTS260 Temporary Variable Speed Limit Signs	MRTS Clause	Verification Method					Compliance (Y, TBC, N, N/A)
			Visual Inspection	NATA Certification	Field OR Bench Test	Detailed Drawings	Other records (Datasheets, internal testing, RPEQ)	
221	The sign enclosure must house the sign displays and associated control electronics and comply with the relevant requirements of MRTS201 <i>General Equipment Requirements</i> .	10.3					X	
222	The size of the speed limit display shall be as defined in AS 1744.	10.3.1					X	
223	The size of the TVSL sign shall be as specified in the contract.	10.3.1					X	
224	The enclosure shall be sufficiently sized for the size of the speed limit sign display.	10.3.1					X	
225	The total external dimensions of the housing shall not be more than 150 mm larger than the required sign face.	10.3.1					X	
226	The sign numeric displays must be based on a series of pixels forming a dot matrix display system.	10.3.1					X	
227	The horizontal and vertical pitch of the pixels in the matrix must be the same.	10.3.1					X	
228	The apparent width of all displayed elements including text must match the respective sign display defined in the MUTCD.	10.3.1					X	
229	The TVSL LED sign display component must be fully self-contained and capable of being removed and installed on site by hand via the access door(s) for maintenance.	10.3.1					X	
230	The display must be physically capable of displaying speeds from 40 km/hr up to the 110 km/hr for the TVSL site in 10 km/hr increments.	10.3.1					X	
231	The actual speed range for each site must be confirmed with the Principal during the commissioning activities and retained as part of the non-volatile information stored in the DP.	10.3.1					X	
232	Only those frames permitted to be displayed at the site of installation shall be programmed into the DP.	10.3.1					X	
233	Access doors and hatchways required for maintenance, configuration and stowage shall be secured via a key lock mechanism.	10.3.2					X	

Item#	MRTS260 Temporary Variable Speed Limit Signs	MRTS Clause	Verification Method					Compliance (Y, TBC, N, N/A)
			Visual Inspection	NATA Certification	Field OR Bench Test	Detailed Drawings	Other records (Datasheets, internal testing, RPEQ)	
234	All doors and hatchways shall prevent any moisture ingress into the compartments and have ingress protection rating of IP56.	10.3.2		X				
235	A protective front cover must be fitted to the TVSL sign enclosure to form a viewing window.	10.3.3					X	
236	The front cover material must be a single, clear Lexan® sheet or equivalent, and have a non-reflective finish.	10.3.3					X	
237	The sheeting must be manufactured from sign-grade material SG300 with a thickness at least equal to that recommended by the manufacturer, with an absolute minimum of 4.5 mm.	10.3.3					X	
238	The viewing window must be such that when installed, the sides and bottom edges of the display face are fully visible at viewing angles of $\pm 45^\circ$ (horizontal) and $\pm 60^\circ$ (vertical) to the axis perpendicular to the front plane of the display.	10.3.3					X	
239	The front cover must include a clear, non-reflective polycarbonate front screen.	10.3.3					X	
240	Suitable means must be provided to demist the front screen.	10.3.3					X	
241	The front cover must be able to be removed for maintenance without requiring removal of internal components.	10.3.3					X	
242	The front cover retention and seal design must allow for thermal expansion properties of the front cover material.	10.3.3					X	
243	The front cover surrounding framework and cover strips must provide the required weather proofing and strength for both positive and negative wind pressures and, where applicable, tunnel deluge systems.	10.3.3					X	
244	The front covers shall be fastened to the sign display enclosure through security screws or other secure fastening methods.	10.3.3					X	
245	In respect to the front viewing window, where installed, shall be made from anti-glare and U.V.	10.3.3					X	
246	stabilised polycarbonate with a minimum thickness of 4.5 mm.	10.3.3					X	

Item#	MRTS260 Temporary Variable Speed Limit Signs	MRTS Clause	Verification Method					Compliance (Y, TBC, N, N/A)
			Visual Inspection	NATA Certification	Field OR Bench Test	Detailed Drawings	Other records (Datasheets, internal testing, RPEQ)	
247	The materials used for the trailer mounted TVSL enclosure shall be aluminium as specified in AS 5156, suitably reinforced and/or braced to facilitate the installation and continued operation of the unit in the intended application.	10.3.4					X	
<b>11 Electrical requirements</b>								
248	Portable signs shall be solar powered in accordance with the requirements of MRTS263 <i>Standalone Solar (PV) Power Systems</i> and the relevant requirements of AS 5156.	11.1					X	
249	Each sign shall also have the facility to be mains powered so the batteries can be charged before being deployed to site or while at site.	11.1					X	
250	This shall include a mains battery charger and an IP65 rated locking connector to enable the external power supply to be easily connected and disconnected from the sign.	11.1					X	
251	The relevant electrical requirements defined in Clause 10 of MRTS201 <i>General Equipment Requirements</i> apply.	11.1					X	
252	Fixed signs shall be mains powered, with an IP65 rated locking connector to enable the external power supply to be easily connected and disconnected from the sign, and with surge protection and battery power supply in accordance with the requirements of Clause 10 of MRTS201 <i>General Equipment Requirements</i> and the relevant requirements of AS 5156.	11.2					X	
253	Where specified, lightning protection shall be provided to AS/NZS 1768.	11.2					X	
254	The power system log is used for discerning the proper operation of the power system.	11.3					X	
255	The DP shall log the electrical parameters (referred to in Clause 9) for each connected sign within the roadwork site.	11.3					X	
256	For solar charge current / voltage, load current and battery charge voltage, the DP will aggregate the measurements that it receives from the connected signs over a one-hour period.	11.3					X	

Item#	MRTS260 Temporary Variable Speed Limit Signs	MRTS Clause	Verification Method					Compliance (Y, TBC, N, N/A)
			Visual Inspection	NATA Certification	Field OR Bench Test	Detailed Drawings	Other records (Datasheets, internal testing, RPEEQ)	
257	Each sign shall report no less than four measurements for each parameter per hour to the connected DP.	11.3					X	
<b>12 Sign display requirements</b>								
258	The display technology must be light emitting diode (LED).	12.1					X	
259	To achieve the required sign luminance levels, the display pixels may be formed by arranging one or more LEDs in a cluster.	12.1					X	
260	Each individual LED must be driven with a continuous current with no peak and/or magnitudes exceeding 70% of the LED manufacturer's maximum continuous rating.	12.2					X	
261	For LEDs in a 5 mm or smaller diameter package, peak magnitudes of the LED current shall not exceed the manufactured rated driving current.	12.2					X	
262	The display of numerals for the purpose of speed regulation and information must comply as much as practicable with the fonts defined in MUTCD.	12.3					X	
263	Numerals must meet the fonts defined for use on a Regulatory Sign R4-1.	12.3					X	
264	The annulus must not be less in size than that required for an equivalent static sign.	12.3					X	
265	The minimum legibility (sight) distance and character height must be as indicated in the Table 12.3 below for both daytime and night-time viewing.	12.3					X	
266	Refer to traffic control drawings TC1785 1 and 2 for dimensions of the TVSL sign display.	12.3					X	
267	Character heights are specified in standard signs R4-1 and vary according to whether two or three numerals are displayed.	12.3					X	
268	Display changes must be affected by blanking the display, and then activating all required pixels of the new frame simultaneously.	12.4					X	
269	Scrolling of images is not permitted.	12.4	X				X	
270	All signs connected to a DP that are instructed to display the same frame must display that frame simultaneously.	12.4					X	

Item#	MRTS260 Temporary Variable Speed Limit Signs	MRTS Clause	Verification Method					Compliance (Y, TBC, N, N/A)
			Visual Inspection	NATA Certification	Field OR Bench Test	Detailed Drawings	Other records (Datasheets, internal testing, RPEQ)	
271	The sign shall prevent the concurrent display of two frames.	12.4					X	
272	There must be no discernible flickering of the display.	12.4					X	
273	Background flickering because of checking the 'on' and 'off' pixel status must not be visible.	12.4					X	
274	The display must be able to be reproduced with all required active pixels by camera with shutter speed of up to 1/2000 s. Upon displaying a new frame, the previously displayed frame shall be removed from the sign's memory.	12.4					X	
275	The display must be generated by red and white LEDs on a matte black background.	12.5					X	
276	The red and white colours must fall within the chromaticity coordinates specified in AS 5156.	12.5		X				
277	Facilities must be included to detect failures within the display control system with the sign defaulting to pre-determined display when major faults are detected.	12.6					X	
278	The sign shall blank the display in the event of a sign processor fault.	12.6					X	
279	Time to blank shall be a configurable and the range and factory default settings are shown in Appendix A.	12.6					X	
280	The sign display must monitor communications with the DP and blank the display if loss of communication experienced.	12.6			X		X	
281	The communications timeout period shall be configurable, and the range and factory default settings are shown in Appendix A.	12.6					X	
282	The sign shall be able to detect LED failure even if the LEDs may be required to be 'off' at the time of the periodic check.	12.6					X	
283	The display must be blanked upon failure of 2% of contiguous pixels for each displayed image or failure of more than 20% of LEDs.	12.6					X	
284	Single LED failure, provided that the cumulative LED loss remains below the 2% and/or 20% thresholds described above or TVSL light sensor failure, should not result in blanking of the display.	12.6					X	

Item#	MRTS260 Temporary Variable Speed Limit Signs	MRTS Clause	Verification Method					Compliance (Y, TBC, N, N/A)
			Visual Inspection	NATA Certification	Field OR Bench Test	Detailed Drawings	Other records (Datasheets, internal testing, RPEQ)	
285	Loss of power shall result in blanking of the display.	12.6					X	
286	On power restoration, the sign shall become available for activation and remain blank until commanded by the DP.	12.6					X	
287	At no time shall partial or incomplete frames be displayed.	12.6					X	
288	The red annulus must consist of suitably constructed, evenly spaced pixel rings in accordance with Table 12.7 below.	12.7					X	
289	The number of rings to flash shall be counted from the inner ring.	12.7					X	
290	The outer ring(s) shall maintain an apparent solid ring to satisfy the regulatory status of the sign.	12.7					X	
291	When displaying the default speed limit, all pixel rings of the annulus must be illuminated.	12.7					X	
292	The annulus shall be constructed so that LEDs connected in series are separated physically by at least three LEDs from other circuits.	12.7					X	
293	The sign shall allow selectable flashing of the whole and/or part of the display via all the communications ports.	12.8					X	
294	The flash rate parameters must be configurable and be selectable via all the communications ports as specified in Appendix A.	12.8					X	
295	The red annulus must be designed so that the inner rings of the annulus can be flashed as an independent event.	12.8.1					X	
296	In partial flash mode, between 50% and 75% of the total number of annulus pixel rings must flash.	12.8.1					X	
297	The inner diameter pixel ring(s) of the annulus must flash while the remaining outer ring(s) of the annulus must remain lit.	12.8.1					X	
298	No conspicuity devices or lanterns are required.	12.8.2					X	
299	However, the sign shall allow conspicuity devices to be added in future if desired.	12.8.2					X	

Item#	MRTS260 Temporary Variable Speed Limit Signs	MRTS Clause	Verification Method					Compliance (Y, TBC, N, N/A)
			Visual Inspection	NATA Certification	Field OR Bench Test	Detailed Drawings	Other records (Datasheets, internal testing, RPEQ)	
300	The optical performance must be determined by measurement under laboratory conditions of the following parameters listed in Tables 12.3 and 12.9.3 below: a) minimum luminance ratio b) minimum and maximum luminance and luminous intensity uniformity c) viewing angle, and d) colour as per AS 156.	12.9.1		X				
301	The performance of the TVSL sign displays must meet or exceed the luminance and chromaticity parameters defined in AS 5156.	12.9.1		X				
302	The luminance of the LEDs, when measured under laboratory conditions, must comply with the requirements of AS 5156.	12.9.2		X				
303	The luminance intensity half angle must comply with Table 12.9.3.	12.9.3		X				
304	The effect of sunlight or other light sources shining on the optical elements must be controlled such that inactive pixels do not appear active.	12.9.4		X				

Superseded