

Superseded

Technical Specification

**Transport and Main Roads Specifications
MRTS97 Mounting Structures for Roadside Equipment**

July 2022

Copyright

© The State of Queensland (Department of Transport and Main Roads) 2022.

Licence



This work is licensed by the State of Queensland (Department of Transport and Main Roads) under a Creative Commons Attribution (CC BY) 4.0 International licence.

CC BY licence summary statement

In essence, you are free to copy, communicate and adapt this work, as long as you attribute the work to the State of Queensland (Department of Transport and Main Roads). To view a copy of this licence, visit: <https://creativecommons.org/licenses/by/4.0/>

Translating and interpreting assistance



The Queensland Government is committed to providing accessible services to Queenslanders from all cultural and linguistic backgrounds. If you have difficulty understanding this publication and need a translator, please call the Translating and Interpreting Service (TIS National) on 13 14 50 and ask them to telephone the Queensland Department of Transport and Main Roads on 13 74 68.

Disclaimer

While every care has been taken in preparing this publication, the State of Queensland accepts no responsibility for decisions or actions taken as a result of any data, information, statement or advice, expressed or implied, contained within. To the best of our knowledge, the content was correct at the time of publishing.

Feedback

Please send your feedback regarding this document to: tmr.techdocs@tmr.qld.gov.au

Contents

- 1 Introduction 1**
- 1.1 Rate 3 Road lighting mounting structures 1
 - 1.1.1 *Critical design case* 1
 - 1.1.2 *Other combinations* 1
- 1.2 Pathway lighting mounting structures 1
- 1.3 Traffic signal mounting structures 1
- 1.4 ITS equipment mounting structures 1
- 2 Definition of terms 1**
- 3 Referenced documents 2**
- 3.1 Standards 2
- 3.2 Standard Drawings 3
- 4 Quality system requirements 4**
- 4.1 Hold Points, Witness Points and Milestones 4
- 5 Design requirements 4**
- 5.1 General 4
- 5.2 Wind loading 5
- 5.3 Load combinations 5
- 5.4 Design approval 5
- 5.5 Additional requirements for road and pathway lighting poles 6
 - 5.5.1 *Aerial connection* 6
 - 5.5.2 *Deflection lighting poles (including hinged poles for lighting)* 6
 - 5.5.3 *Tip loading* 6
 - 5.5.4 *Hinged poles* 6
 - 5.5.5 *Proof loading* 7
 - 5.5.6 *Frangible poles* 7
 - 5.5.7 *Outreach arms, extensions and head frames* 8
 - 5.5.8 *Solar panel fitted on road lighting poles* 9
- 5.6 Pathway lighting poles 9
- 5.7 Requirements for traffic signal and ITS mounting structures 9
 - 5.7.1 *CCTV camera* 9
 - 5.7.2 *CCTV camera on traffic signal mast arm* 10
 - 5.7.3 *CCTV camera on a pole* 10
 - 5.7.4 *Hinged poles for CCTV camera* 10
- 5.8 Slip base mount design parameters 10
- 5.9 Poles on bridge structures 10
 - 5.9.1 *Lampstand brackets design parameters* 10
- 5.10 Materials 11
 - 5.10.1 *Steel grade and minimum steel thickness* 11
 - 5.10.2 *Alternative materials* 11
- 6 Fabrication 11**
- 6.1 Fabrication requirements 11
- 6.2 Pole identification 12
- 6.3 Slip base mounts 12

6.4	Miscellaneous materials	12
7	Testing	12
7.1	Poles	12
8	Handling, transport and storage	13
9	Supplementary requirements	13
	Attachments	14
	Attachment 1 – Road lighting pole design parameters	14
	Attachment 2 – Outreach arms and extension and luminaire headframe design parameters	15
	Attachment 3 – Slip base mount design parameters	16
	Attachment 4 – Design parameters for other combinations	17
	Attachment 5 – Pathway lighting pole design parameters	18
	Attachment 6 – Pathway solar lighting pole design parameters	19
	Attachment 7 – Base plate mounted hinged CCTV pole design parameters	20
	Appendix A: General arrangements of road lighting installations.....	21

Superseded

1 Introduction

This Technical Specification provides the structural requirements for the design and manufacture of mounting structures such as poles, posts and mast arms.

1.1 Rate 3 Road lighting mounting structures

1.1.1 Critical design case

- a) base plate mounted poles (Figure 1, 4 and 5, SD1370 and SD1371)
- b) base plate mounted joint use poles (JUP) (SD1370, SD1377)
- c) slip base mounted poles (Figures 1, 6 and 7, SD1370 and SD1372)
- d) energy absorbing poles (Figure 8), and
- e) baseplate mounted hinged poles (Figure 9).

1.1.2 Other combinations

- a) high mast poles (Figure 1, SD1370 and SD1375)
- b) pedestrian crossing flood light poles (Figure 1, SD1376, SD1335 and SD1336), and
- c) solar panel fitted on standard poles (Figure 10).

1.2 Pathway lighting mounting structures

- a) baseplate mounted poles with integral outreach (SD1682)
- b) baseplate mounted hinged poles with integral outreach (SD1682), and
- c) baseplate mounted poles fitted with solar panel (Figure 11).

1.3 Traffic signal mounting structures

- a) posts (SD1420, Figures 12), and
- b) mast arms (Figures 13 and 14).

1.4 ITS equipment mounting structures

- a) camera mounting adaptors (Figure 15)
- b) camera on traffic signal mast arm (Figure 16 and Figure 17), and
- c) base plate mounted hinged camera poles (Figure 18).

This Technical Specification does not apply to Rate 1 or 2 road lighting poles. For Rate 1 or 2 lighting poles reference shall be made to the relevant Electricity Entity policies, standards and Technical Specifications.

This Technical Specification shall be read in conjunction with MRTS01 *Introduction to Technical Specifications*, MRTS50 *Specific Quality System Requirements* and other Technical Specifications as appropriate.

This Technical Specification forms part of the Transport and Main Roads Specifications Manual.

2 Definition of terms

The terms used in this Technical Specification shall be as defined in Clause 2 of MRTS01 *Introduction to Technical Specifications*. Further definitions are provided in Table 2.

Table 2 – Definition of terms

Term	Definition
Rate 3 lighting poles	Public lighting supplied, installed, owned and maintained by Transport and Main Roads.
ITS devices	Equipment that provides an Intelligent Transport System solution.

3 Referenced documents

3.1 Standards

Table 3.1 lists documents referenced in this Technical Specification.

Table 3.1 – Referenced documents

Reference	Title
AS 1074	<i>Steel tubes and tubulars for ordinary service</i>
AS 1111.1	<i>ISO metric hexagon bolts and screws – Product grade C, Part 1: Bolts</i>
AS 1111.2	<i>ISO metric hexagon bolts and screws – Product grade C, Part 2: Screws</i>
AS 1112.1	<i>ISO metric hexagon nuts, Part 1: Style 1 – Product grades A and B</i>
AS 1112.2	<i>ISO metric hexagon nuts, Part 2: Style 2 – Product grades A and B</i>
AS 1112.3	<i>ISO metric hexagon nuts, Part 3: Product grade C</i>
AS 1112.4	<i>ISO metric hexagon nuts, Part 4: Chamfered thin nuts – Product grades A and B</i>
AS/NZS 1214	<i>Hot-dip galvanised coatings on threaded fasteners (ISO metric coarse thread series) (ISO 10684:2004, MOD)</i>
AS 1275	<i>Metric screw threads for fasteners</i>
AS 1450	<i>Steel tubes for mechanical purposes</i>
AS 1721	<i>General purpose metric screw threads</i>
AS 1789	<i>Electroplated zinc (electrogalvanized) coatings on ferrous articles (batch process)</i>
AS 1798	<i>Lighting poles and bracket arms – Recommended dimensions</i>
AS 2700	<i>Colour standards for general purposes</i>
AS 2837	<i>Wrought alloy steels – Stainless steel bars and semi-finished products (withdrawn)</i>
AS 3600	<i>Concrete structures</i>
AS 4068	<i>Flat pallets for material handling (withdrawn)</i>
AS 4100	<i>Steel structures</i>
AS/NZS 3679.1	<i>Structural steel, Part 1: Hot-rolled bars and sections</i>
AS/NZS 3679.2	<i>Structural steel, Part 2: Welded I sections</i>
AS/NZS 1170.0	<i>Structural design actions, Part 0: General principles</i>
AS/NZS 1170.1	<i>Structural design actions, Part 1: Permanent, imposed and other actions</i>
AS/NZS 1170.2	<i>Structural design actions, Part 2: Wind actions</i>
AS/NZS 1252.1	<i>High strength steel fastener assemblies for structural engineering – Bolts, nuts and washers, Part 1: Technical requirements</i>

Reference	Title
AS/NZS 1252.2	<i>High-strength steel fastener assemblies for structural engineering – Bolts, nuts and washers, Part 2: Verification testing for bolt assemblies</i>
AS/NZS 1554.1	<i>Structural steel welding, Part 1: Welding of steel structures</i>
AS/NZS 1594	<i>Hot-rolled steel flat products</i>
AS/NZS 3678	<i>Structural steel – Hot-rolled plates, floorplates and slabs</i>
AS/NZS 3845.1	<i>Road safety barrier systems and devices, Part 1: Road safety barrier systems</i>
AS/NZS 3845.2	<i>Road safety barrier systems and devices, Part 2: Road safety devices</i>
AS/NZS 4065	<i>Concrete utility services poles (withdrawn)</i>
AS/NZS 4671	<i>Steel for the reinforcement of concrete</i>
AS/NZS 4676	<i>Structural design requirements for utility services poles (withdrawn)</i>
AS/NZS 4680	<i>Hot-dip galvanized (zinc) coatings on fabricated ferrous articles</i>
AS/NZS ISO 9001	<i>Quality management systems – Requirements</i>
BS 5649.8	<i>Method for verification of structural design by testing</i>
MRTS01	<i>Introduction to Technical Specifications</i>
MRTS50	<i>Specific Quality System Requirements</i>
MRTS78	<i>Fabrication of Structural Steelwork</i>
MRTS94	<i>Road Lighting</i>
NCHRP 350	<i>Recommended Procedures for the Safety Performance Evaluation of Highway Features</i>

3.2 Standard Drawings

Table 3.2 lists the department's Standard Drawings referenced in this Technical Specification or relevant to the design and manufacture of mounting structures, construction maintenance and operation of Road Lighting.

Table 3.2 – Referenced Standard Drawings

Drawing	Number Title
1328	<i>Road Lighting / ITS – Lighting / Camera Pole Anchor Cage Fabrication Details</i>
1335	<i>Road Lighting – Pedestrian Crossing Floodlight Mounting Bracket Outreach Mount (Option 2)</i>
1336	<i>Road Lighting – Pedestrian Crossing Floodlight Mounting Bracket Spigot Mount (Option 1)</i>
1370	<i>Road Lighting – General Arrangements</i>
1371	<i>Road Lighting – Base Plate Mounted Pole</i>
1372	<i>Road Lighting – Slip Base Pole</i>
1373	<i>Road Lighting – Base Plate Mounted Pole in Concrete Median Barrier</i>
1375	<i>Road Lighting – High Mast Pole</i>

Drawing	Number Title
1376	<i>Road Lighting – Base Plate Mounted Pole with Pedestrian Crossing Floodlight</i>
1377	<i>Traffic Signal / Road Lighting – Joint Use Traffic Signal and Road Lighting Pole</i>
1389	<i>Slip Base Pole Male / Female Connectors Installation Details</i>
1420	<i>Traffic Signals – General Arrangement</i>
1682	<i>Pathway Lighting – Typical Lighting Requirements for Off-Road Pathways</i>
1755	<i>Slip Base Tethering System for Transport and Main Roads Rate 3 Lighting Poles</i>

4 Quality system requirements

4.1 Hold Points, Witness Points and Milestones

General requirements for Hold Points, Witness Points and Milestones are specified in Clause 5.2 of MRTS01 *Introduction to Technical Specifications*.

The Hold Points, Witness Points and Milestones applicable to this Technical Specification are summarised in Table 4.1.

Table 4.1 – Hold Points, Witness Points and Milestones

Clause	Hold Point	Witness Point	Milestone
5.4	1.Design Approval Poles, Posts and Mast Arms		
7.1	2.Testing of poles and components	1. Submission of pole design calculations (7 days)	Submission of revised pole design calculations (7 days)

5 Design requirements

Refer Clause 1 for relevant structure types.

5.1 General

The standard light poles fall into five critical design cases outlined in Clause 1.1.1 of this specification. The design parameters for these critical design cases are shown in Attachment 1. Attachment 2 and 3 show the design parameters for the mounting devices associated with the critical design case.

Other combination of poles based on the critical design cases are outlined in Clause 1.1.2.

Attachment 4 shows the design parameters for other combination of poles.

All structures shall be designed to withstand without permanent deformation for the worst combination of the following loadings:

- a) dead load of the pole, post, mast arm and its attached components and equipment
- b) wind load on the pole, post, mast arm and its attached components and equipment, and
- c) load applied by any aerial supply cables.

The design strength of poles and posts including foundation shall be calculated in accordance with the requirements of AS 4100, AS 3600, AS/NZS 1594, AS/NZS 3678, AS/NZS 4065 and AS/NZS 4676, as appropriate.

Design parameters are stated in Attachment 1-7 *Road Lighting Pole Design Parameters* to this Technical Specification.

5.2 Wind loading

The design wind loads shall be determined from the methods detailed in AS/NZS 1170.2 using the design wind V_{design} as stated in Table 5.2.2.

Table 5.2.2 – Design wind speed

Height (m)	V_{design} (m/s)	
	V_s Serviceability	V_u Ultimate
15	29	57
10	27	53
5	25	50
< 3	23	47

Drag coefficients for poles, posts and mast arm for wind load calculations shall be 1.0 for luminaires, 1.2 for outreach arms and 1.0 for traffic signals, cameras and 1.5 for solar panels.

Design ultimate wind velocities shown in Table 5.2.2 were derived as follows:

- From AS 1170.2 Table 3.1, Region B wind speed for average recurrence interval $R = 250$ years is computed from $V_R = 106-92R^{0.1}$. Hence $V_{R=250} = 53$ m/s.
- Using $M_{z,\text{cat}}$ from Table 4.1B for terrain categories 1 and 2 in region C and D and adopting M_d , M_s and M_t all equal to 1, the ultimate $V_{\text{design}} = 53 * M_d (M_{z,\text{cat}} * M_s * M_t)$.

5.3 Load combinations

Load combinations of dead loads, live loads and wind loads for design purposes shall be in accordance with AS/NZS 1170.0.

5.4 Design approval

Design shall be submitted for review and approval by the Director (Technical Governance) Engineering and Technology branch of the Department of Transport and Main Road, prior to commencement of fabrication. **Hold Point 1**

The design shall be certified by a person experienced in the design of all categories of poles given above and holding current registration as a Registered Professional Engineer, Queensland.

All pole designs shall be supplied with the following information.

- RPEQ Certified Engineering drawings, and
- full detailed calculations, including structural analysis and design.

Contact details are:

Director (Technical Governance)
Structures, Engineering and Technology
Department of Transport and Main Roads
GPO Box 1412
Brisbane, Qld, 4001

5.5 Additional requirements for road and pathway lighting poles

5.5.1 Aerial connection

In addition to any wind loading, road lighting poles fitted with aerial supply cable shall be designed to withstand an ultimate static force of 1 kN exerted by the aerial cable.

The aerial connection shall be applied horizontally in any direction 125 mm below the spigot line on poles up to 10 metres high and 3125 mm below the spigot line on poles exceeding 10 metres high.

5.5.2 Deflection lighting poles (including hinged poles for lighting)

The deflection of the pole from the vertical position under serviceability limit state shall be calculated according to AS/NZS 1170.2 and shall not exceed 4% of the vertical section height of the pole measured at the base of the outreach arm fixing spigot.

5.5.3 Tip loading

The maximum allowable tip load shall be indelibly marked on the name plate of each pole manufactured.

The maximum allowable tip load is defined as the maximum continuous load that can be applied horizontally (in any direction) to the base of the outreach arm fixing spigot with the pole installed in its normal vertical working position.

5.5.4 Hinged poles

Hinged poles shall be base plate mounted type with an underground power supply.

Hinged poles have two applications – lighting (Figure 9) and CCTV (Figure 18). The top of the pole shall consist of either:

- spigot for luminaire headframe, or
- a spigot to support a camera-mounting adaptor that supports the pan/tilt CCTV camera unit.

An access hatchway shall be located such that it is unobstructed by the hinged section of the pole, i.e. perpendicular to the swing direction. The hatchway size shall be:

- a) 600 mm x 150 mm on 350 mm PCD poles, or
- b) 600 mm x 230 mm on 500 mm PCD poles.

The top of the hatchway shall be a maximum of 1500 mm above the base of the pole. The mast arm shall be above the access hatch. The tilt pole complete with luminaires or cameras shall be such that the outreach spigot or camera mounting plate when lowered shall be at a height of between 1200 mm and 1400 mm above the pole base.

The pole shall be designed such that it is not possible for the luminaires or camera equipment to touch the lower section of the pole. Pulling eyes shall be located on the flap and at the pole base so that a rope may be used to raise the hinged section and regulate the lowering speed of the hinged section.

The pole shall have two independent latching systems to hold the flap in place, each of sufficient strength to restrain the pole from lowering. One system shall comprise a tamper proof stainless steel bolt of appropriate strength to hold the flap rigidly to the pole free from movement.

This lock down retaining bolt shall be located between 900 mm and 1500 mm above the pole base.

The other system shall comprise a lug welded to the inside face of the flap and protruding through the lower pole section when in the upright position. The lug shall have a hole through it to allow for padlock. It shall be possible to install the padlock to the inside of the pole via the hatchway.

Counterweights of appropriate mass shall be provided for different hinged pole sizes to achieve rotational balance. Individual counterweights shall not have a mass greater than 10 kg.

The connecting pin and the lower section of the swing arm shall be designed to resist shear forces and bending moment generated by dead, live and wind loads. The pivot hinge shall be adequately welded to the base section of the pole.

5.5.5 Proof loading

The pole supplier shall state the maximum bending moment and shear force that is applied at the pole base level for all poles, for serviceability and ultimate limit states.

5.5.6 Frangible poles

Frangible poles shall be either slip base mounted or energy absorbing type.

Slip base mounted poles shall conform to the requirements of this Technical Specification and Figures 6 and 7 shown in Appendix A.

Energy absorbing poles shall conform to the requirements of Clauses 5.5.6.1 and 5.5.6.2 of this Technical Specification and Figure 8 shown in Appendix A.

5.5.6.1 Energy absorbing pole crash behaviour

Energy absorbing poles shall deform progressively when a vehicle crashes into them. The poles shall be designed to deform progressively so as to decelerate an impacting vehicle in a controlled and uniform manner.

The base of an energy absorbing pole shall remain attached to the footing after impact and the pole shall collapse upon vehicle impact in a predictable and acceptable manner.

5.5.6.2 Energy absorbing pole crash performance tests

The pole supplier shall supply evidence of full scale impact testing, carried out by an organisation with accredited data collection system. The Director (Technical Governance) shall assess the adequacy and suitability of the poles as being energy absorbing.

Poles shall be demonstrated to fall or collapse in a safe fashion so as to be not likely to cause injury to occupants in the impacting vehicle or to other vehicles on the road. The final position of the pole should not be expected to be on the road.

Two tests are required. The first is at 50 km/h and the second at 100 km/h by vehicles with a mass of 820 kg.

The first test is to demonstrate that the failure or collapse mechanism is effective and will occur at 50 km/h.

The second test is to evaluate vehicle stability and trajectory and also the trajectory of the pole.

The Occupant Ride-down Acceleration (ORA) and Occupant Impact Velocities (OIV) must be calculated in accordance with NCHRP 350, which is the basis of the testing procedure in AS/NZS 3845.

The OIV should be in the range for longitudinal velocity components that is 9 m/s preferred and 12 m/s maximum. These OIV values are calculated when an occupant is expected to be at the limit of the flail space. This is when the occupant has travelled either 600 mm in the forward direction or 300 mm laterally. The ORA should be less than 15 g preferably and with a maximum of 20 g averaged over a moving 10 milliseconds period after occupant has reached the limits of the flail space.

The point of impact is to be on the centre line of the vehicle. The pole and the vehicle must be brought to rest in a safe and controlled manner. Any pitch, yaw or roll shall be noted with the ORA and OIV.

The pole design must also include an electrical disconnect method acceptable to the Administrator.

With regard to the above crash performance criteria and electrical disconnect method, the Administrator reserves the right to:

- a) accept any pole type where satisfactory evidence indicates that the above requirements are substantially, but not precisely, met
- b) waive the right to further testing where the pole design has been previously tested and found to be satisfactory, or
- c) reject any pole type.

5.5.7 Outreach arms, extensions and head frames

All outreach arms and extensions shall be designed to withstand, without permanent deformation, the worst combination of the following loadings:

- a) dead load due to outreach arm, extension and luminaire, and
- b) wind load on outreach arm, extension and luminaire.

All luminaire head frames shall be designed to withstand, without permanent deformation, the worst combination of the following loadings:

- a) dead load due to luminaire head frame and luminaire, and
- b) wind load on luminaire head frame and luminaire.

Design strength of an outreach arm and extension, and luminaire head frame, shall be calculated in accordance with the requirements of AS 4100, as appropriate.

Design parameters are detailed in Attachment 2 *Outreach Arms and Extensions; and Luminaire Head frames Design Parameters* to this. The wind loading shall be determined in accordance with Clause 5.2.

Load combinations shall be determined by the method detailed in Clause 5.3.

An outreach arm shall be designed so that, under dead load with luminaire and outreach arm extension, where fitted, the luminaire fixing spigot, spigot angle shall not be less than 5 degrees nor greater than 7 degrees.

The deflection of the outreach arm when fitted to a fixed non-deflecting spigot, under the serviceability limit state, shall be calculated in accordance with AS/NZS 1170.2 and shall not exceed 4% of the nominal horizontal outreach length.

5.5.8 Solar panel fitted on road lighting poles

5.5.8.1 Dedicated solar pole with luminaire

All dedicated solar pole with luminaire design shall ensure that the following maximum design parameters as stated in Table 5.5.8.1 are accounted for in the design and the related values are to be shown on the design drawings. The solar pole shall be designed based on the worst orientation of the solar panel such that the sail area attracts the highest wind load.

Table 5.5.8.1 – Design parameters

Design Parameters	Value
Solar panel dimensions	1500 x 650 x 35 mm
Solar panel weight including the steel frame	40 kg Solar panel weight = 15 kg Steel frame weight = 25 kg
Angle of installation	20 - 50 depending on the latitude
Luminaire weight	15 kg
Luminaire sail area	0.17 m ²

5.5.8.2 Solar panels fitted on standard lighting poles

This Technical Specification restricts the use of solar panels on two standard road lighting poles of pole heights 7.0 m and 8.5 m. One single outreach arm with or without extension is permitted in these two heights and the design parameters are outlined in Attachment 4. The maximum design parameters for solar panels and luminaire shall be as given in Table 5.5.8.1. Figure 10 outlines the dimension and solar panel mounting height for these two standard pole sizes.

5.6 Pathway lighting poles

Pathway lighting poles falls into three categories as outlined in Clause 1.2 of this Technical Specification.

Design parameters for pathway lighting poles with a vertical height of 5 m (hinged pole), and 6.5 m (non-hinged pole) are detailed in Attachment 5.

Design parameters for pathway solar lighting poles with a height of 5.0 m are shown in Attachment 6. Figure 11 outlines the dimensional and solar panel mounting height requirements for pathway solar lighting poles.

Pathway lighting poles and pathway solar lighting poles shall not be interchangeable.

5.7 Requirements for traffic signal and ITS mounting structures

Traffic signal general arrangements are shown in SD1420.

Traffic signal post and mast arm drawings shown in Figures 12-14 are design drawings and are not shop drawings for fabrication.

5.7.1 CCTV camera

CCTV camera weight including the bracket shall be 20 kg and the sail area is 0.11 m².

5.7.2 CCTV camera on traffic signal mast arm

CCTV camera mounting adaptor shall be connected to the traffic signal mast arm as shown in Figure 15. The relevant mast arm shall be selected in erecting the CCTV adaptor, as shown on the drawing.

5.7.3 CCTV camera on a pole

CCTV camera mounting adaptor on a pole shall be connected on a traffic signal mast arm as shown in Figure 16 and 17. The relevant mast arm/joint use pole shall be selected as shown on Figures 13 - 15.

5.7.4 Hinged poles for CCTV camera

Design parameters for hinged poles for CCTV camera are defined in Attachment 7.

CCTV camera on a hinged pole as shown in Figure 18 shall confirm to Clause 5.5.4 of this Technical Specification.

The deflection of the pole from the vertical position under serviceability limit state shall be calculated according to AS/NZS 1170.2 and shall not exceed 1% of the vertical section height of the pole measured at the base of the outreach arm fixing spigot.

5.8 Slip base mount design parameters

All slip base mounts shall be designed to withstand without permanent deformation for the worst combination of the following loadings:

- a) dead load due to pole, outreach arm, extension and luminaire, and
- b) wind load on pole, outreach arm, extension and luminaire.

The design strength of mounts shall be calculated in accordance with the requirements of AS 4100, AS 3600, AS/NZS 1594, AS/NZS 3678 and/or AS/NZS 4065 as appropriate.

Design parameters are detailed in Attachment 3 *Slip Base Mount Design Parameters* to this Technical Specification.

The wind loading shall be determined in accordance with Clause 5.2.

Load combinations shall be determined in accordance with Clause 5.3

5.9 Poles on bridge structures

Road lighting poles on bridges more than 10 m above ground (measured from the soffit of the light pole base to the ground) shall be designed for wind loading using the actual height above ground to determine the wind load.

For all the other cases, light poles on bridge shall be designed in accordance with the requirements of Clause 5.

5.9.1 Lampstand brackets design parameters

Road lighting poles to be located on a bridge structure shall be mounted on a lamp stand bracket. The lamp stand bracket shall be designed to resist the base loads from a 13 m light pole.

The deflection of the lamp stand bracket from the vertical position under serviceability limit state for a 13 m light pole shall not exceed 5 mm.

5.10 Materials

5.10.1 Steel grade and minimum steel thickness

Steel used in the construction of poles, outreach arms and extensions shall comply with the requirements listed in Table 5.10.1.

Table 5.10.1 – Steel requirements for poles and ancillary equipment

Item Description	Steel Grade (MPa)	Steel Thickness
Pole – base plate mounted	250 minimum	3 mm minimum
Pole – slip base	250 minimum	3 mm minimum
Hinged Pole	250 minimum	3mm minimum
Pole – Energy absorbing	250 minimum	3 mm minimum
Outreach arms	250 minimum	3 mm minimum
Outreach arm extension	350 minimum	3 mm minimum
Luminaire head frame	250 minimum	3 mm minimum
Slip base mount	250 minimum	as per the drawings
Lamp stand bracket base	250 minimum	as per the drawings
Lamp stand bracket post	350 minimum	3 mm minimum
Camera mounting adaptor	250 minimum	3 mm minimum

Steel shall be in accordance with AS/NZS 1594 and/or AS/NZS 3678. Poles posts, outreach arms, outreach arm extensions, luminaire headframes and slip base mounts shall be fabricated in accordance with MRTS78 *Fabrication of Structural Steelwork*.

5.10.2 Alternative materials

Full details of alternative materials including reference to relevant Australian Standards shall be submitted to the Administrator for approval. Alternative materials will be evaluated under the departments Engineering Innovation process. However, Transport and Main Roads reserves the right to accept or reject alternative material.

6 Fabrication

6.1 Fabrication requirements

All steelwork shall be fabricated in accordance with the approved Engineering drawings and MRTS78 *Fabrication of Structural Steelwork*.

Tolerances shall be in accordance with AS 1798 unless otherwise shown in the drawings.

All steelwork shall be hot dipped galvanised after fabrication in accordance with as specified in MRTS78 *Fabrication of Structural Steelwork*. The size of components shall be checked prior to fabrication to ensure that they can be hot-dipped galvanised after fabrication. Double dipping shall be allowed. Where it can be proven that a component is too large to allow hot-dipped galvanising, the design shall be referred to the designer.

Steel shall comply with the requirements of AS/NZS 1594 or AS/NZS 3678 as appropriate.

Welding shall be in accordance with AS/NZS 1554.1.

Walkways and platforms shall have permanent plates secured and displayed in a prominent position stating the design loads for the walkways and platforms. These plates shall be as detailed on the drawings.

6.2 Pole identification

All steel assemblies shall be permanently and legibly identified by means of a stainless steel or aluminium plate. The marking plate shall be stamped and located as shown in the drawings and full details of the plate and method of fixing shall be provided.

In addition to the above requirement for marking, all joint use traffic signal and road lighting poles shall have a warning plate permanently and legibly identified, by means of a stainless steel or aluminium plate. The warning plate shall be stamped and located as shown in the drawings and full details of the plate and method of fixing shall be provided.

6.3 Slip base mounts

All slip base mounts shall be constructed in steel in accordance with the requirements shown in the drawings and this Technical Specification. Electrical components used for the disconnect mechanism shall be as shown on SD1389.

The slip base pole adaptor assembly shall include three M36 bolts, nuts, washers and shear washers.

Each slip base pole shall include a slip base clamping bolt tethering system as shown on Standard Drawing SD1755 *Slip Base Tethering System for Transport and Main Roads Rate 3 Lighting Poles*.

The purpose of using the tethering system is to prevent clamping bolts from being projected at high speed or long distance from the pole when the pole slips upon vehicle impact.

Cable clamp brackets with associated set screw with half nut, flat washers, spring washer and wing nut shall be provided for both the slip base pole and mount.

6.4 Miscellaneous materials

Nuts, screws, bolts and washers, pole markings and all materials necessary to complete the installation of the pole shall be provided as required.

7 Testing

7.1 Poles

Tests shall be carried out, in accordance with this Technical Specification, on one pole, one outreach arm, one outreach arm extension, one luminaire head frame and/or one slip base mount as stated in Clause 1 of Annexure MRTS97.1.

At least seven days prior to such testing, full detailed calculations of pole design, to serve as a comparison with the test results, shall be submitted to the Administrator. **Milestone** Calculations for each item shall be submitted in sufficient detail to prove that the proposed tests are representative of the maximum design loads. The submission shall state the maximum bending moment that may be applied at pole base level of each pole type offered.

Should un-satisfactory failure occur during testing, designs shall be modified and resubmitted in accordance with this clause and further testing carried out. **Witness Point 1**

Where testing is required by this Clause, construction shall not proceed until all tests have been completed successfully and confirmed in writing by the Administrator. **Hold Point 2**

8 Handling, transport and storage

All items supplied shall be suitably packaged to ensure that the items are delivered undamaged giving due consideration to the methods and distance of transport and handling.

Handling (packaging) shall be in accordance with MRTS94 *Road Lighting*.

9 Supplementary requirements

The requirements of MRTS97 *Mounting Structures for Roadside Equipment* are varied by the supplementary requirements given in Clause 3 of Annexure MRTS97.1.

Superseded

Attachments

Attachment 1 – Road lighting pole design parameters

POLES			EQUIPMENT ON POLES									
Pole Type	Vertical Section		Outreach Arm			Luminaire		Aerial Cable		Traffic Signals		
	Height (m)	Figure No.	Up Lift	Type	Figure No.	Mass (kg)	Sail Area (m ²)	Aerial cable connection Requirement	Max Loading (kN)	Type	Mass (kg)	Sail Area (m ²)
Base plate Mounted <i>clause 1.1.1(a)</i>	7.0	4,5	2m	3m double plus 2X1.5 m extensions	2	2x15	2x0.17	yes	1.0	N/A	N/A	N/A
	8.5											
	10.0											
	13.0											
Base late mounted Joint Use <i>clause 1.1.1 (b)</i>	7.0	4,5	2m	3m double plus 2X1.5 m extensions	2	2x15	2x0.17	No	N/A	2x6 aspect 300mm incl. target boards plus pedestrian lantern	N/A	N/A
	8.5											
	10.0											
Slip base mounted <i>clause 1.1.1 (c)</i>	7.0	6,7	2m	3m double plus 2X1.5 m extensions	2	2x1.5	2x0.17	No	N/A	N/A	N/A	N/A
	8.5											
	10.0											
	13.0											
Energy absorbing <i>clause 1.1.1 (d)</i>	7.0	8	2m	3m double plus 2X1.5 m extensions	2	2x15	2x0.17	No	N/A	N/A	N/A	N/A
	8.5											
	10.0											
	13.0											
Baseplate mounted hinged <i>clause 1.1.1 (e)</i>	10.0	9	N/A	4 way adaptor luminaire head frame	3	4x15	4x0.17	No	N/A	N/A	N/A	N/A
	13.0											

Attachment 2 – Outreach arms and extension and luminaire headframe design parameters

Component	Figure no.	Outreach Arm	Equipment Attached to Outreach Arm or Headframe		
		Length (metres)	Outreach Extension	Luminaire	
				Mass (kg)	Sail Area (m ²)
Single Outreach	2	1.5	1.5 metres	15	0.17
		3.0			
		3.0	N/A	2 x 15	2 x 0.17
				Refer to Standard Drawings number 1335	
Double Outreach		1.5	1.5 metres	2 x 15	2 x 0.17
		3.0			
Outreach Arm Extension		1.5	N/A	15	0.17
Luminaire Head frame – 1 way Adaptor	3	0.3	N/A	15	0.17
Luminaire Head frame – 2 way Adaptor				2 x 15	2 x 0.17
Luminaire Head frame – 3 way Adaptor				3 x 15	3 x 0.17
Luminaire Head frame – 4 way Adaptor				4 x 15	4 x 0.17

Attachment 3 – Slip base mount design parameters

Mount		Pole		Equipment on Poles								
Flange PCD (mm)	Figure No.	Vertical Section Height (metres)	Figure No.	Outreach Arm		Luminaire		Aerial Cable		Traffic Signals		
				Type	Figure No.	Mass (kg)	Sail Area (m ²)	Aerial Cable Conn. Req'd	Max Loading (kN)	Type	Mass (kg)	Sail Area (m ²)
350	7	7.0	6	3 metre double plus 2 x 1.5 metre extensions	2	2 x 15	2 x 0.17	N/A	N/A	N/A	N/A	N/A
		8.5										
		10.0										
500		13.0										

Superseded

Attachment 4 – Design parameters for other combinations

Pole Type	Vertical Section		Outreach Arm			Luminaire		Solar Panel plus Steel frame		Aerial Cable		Traffic Signals		
	Height (m)	Figure No.	Up Lift	Type	Figure No.	Mass (kg)	Sail Area (m ²)	Mass (kg)	Sail Area (m ²)	Aerial cable connection Requirement	Max Loading (kN)	Type	Mass (kg)	Sail Area (m ²)
High mast base plate or slip base mounted Clause 1.1.2 (f)	10	1	2m	1 Way	3	15	0.17	N/A		Yes if baseplate mounted	1kN	N/A	N/A	N/A
				2 Way		30	2*0.17							
	3 Way			45		3*0.17								
	4 Way			60		4*0.17								
Pedestrian crossing flood light Clause 1.1.2 (g)	7	1	2m	3m single	2	2x15 plus bracket weight	2x0.17	N/A	No	N/A	N/A	N/A	N/A	N/A
	8.5													
	10													
Solar base plate or slip base mounted Clause 1.1.2(h)	7.0	10	2m	1.5m/3m single plus 1.5m extension	2	1x15	1x0.17	40	0.98	No	N/A	N/A	N/A	N/A
	8.5													

Attachment 5 – Pathway lighting pole design parameters

POLE			Equipment on Poles									
POLE TYPE	Vertical Section		Outreach arm/integral			Luminaire		Aerial Cable		Traffic Signals		
	Height (meter)	Figure No.	Up Lift	Type	Figure No.	Mass (kg)	Sail Area (m ²)	Aerial Cable Conn	Max Loading (kN)	Type	Mass (kg)	Sail Area (m ²)
Base Plate Mounted non Hinged <i>Clause 1.2(a)</i>	6.5	SD1682	N/A	0.5m single	SD1682	15	0.17	No	N/A	N/A	N/A	N/A
Base Plate Mounted Hinged <i>Clause 1.2 (b)</i>	5.0	SD1682	N/A	0.5m single	SD1682	15	0.17	No	N/A	N/A	N/A	N/A

Attachment 6 – Pathway solar lighting pole design parameters

POLE			Equipment on Poles											
POLE TYPE	Vertical Section		Outreach arm			Luminaire		Solar Panel + Steel Frame		Aerial Cable		Traffic Signals		
	Height (meter)	Figure No.	Up Lift	Type	Figure No.	Mass (kg)	Sail Area (m ²)	Mass (kg)	Sail Area (m ²)	Aerial Cable Conn	Max Loading (kN)	Type	Mass (kg)	Sail Area (m ²)
Base Plate Mounted <i>Clause 1.2 (c)</i>	5.0	Fig 11	2m	1.5 to 3m single	N/A	15	0.17	40	0.98	No	N/A	N/A	N/A	N/A

Superseded

Attachment 7 – Base plate mounted hinged CCTV pole design parameters

POLE			Equipment on Poles									
POLE TYPE	Vertical Section		Outreach arm/integral			Luminaire		CCTV Camera		Traffic Signals		
	Height (meter)	Figure No.	Up Lift	Type	Figure No.	Mass (kg)	Sail Area (m ²)	Mass including bracket (kg)	Sail Area (m ²)	Type	Mass (kg)	Sail Area (m ²)
Base Plate Mounted Hinged <i>Clause 1.4 (c)</i>	8	Fig 18	N/A	N/A		N/A	N/A	20	0.11	N/A	N/A	N/A
	10											
	12											
	15											

Superseded

Appendix A: General arrangements of road lighting installations

Table of Figures	
Figure 1	Road lighting pole types
Figure 2	Road lighting pole outreach arms and outreach arm extension
Figure 3	Road lighting pole luminaire headframe
Figure 4	Base plate mounted road lighting pole and joint use traffic signal and road lighting pole general arrangement – Sheet 1
Figure 5	Base plate mounted road lighting pole and joint use traffic signal and road lighting pole general arrangement – Sheet 2
Figure 6	Slip base road lighting pole general arrangement – Sheet 1
Figure 7	Slip base road lighting pole general arrangement – Sheet 2
Figure 8	Energy absorbing road lighting pole general arrangement
Figure 9	Base plate mounted hinged road lighting pole general arrangement
Figure 10	Solar road lighting pole general arrangement
Figure 11	Solar pathway lighting pole general arrangement
Figure 12	Base mounted traffic signal post fabrication details
Figure 13	Mast arm and luminaire transition piece general assembly
Figure 14	Traffic mast arm type U2 assembly
Figure 15	CCTV camera mounting adaptor on traffic signal mast arm outreach general assembly and details
Figure 16	CCTV camera post on traffic signal mast arm post general assembly and details
Figure 17	Camera mounting adaptor for CCTV-HSP
Figure 18	Base plate mounted hinged CCTV pole general arrangement

Figure 1 - Road lighting pole types

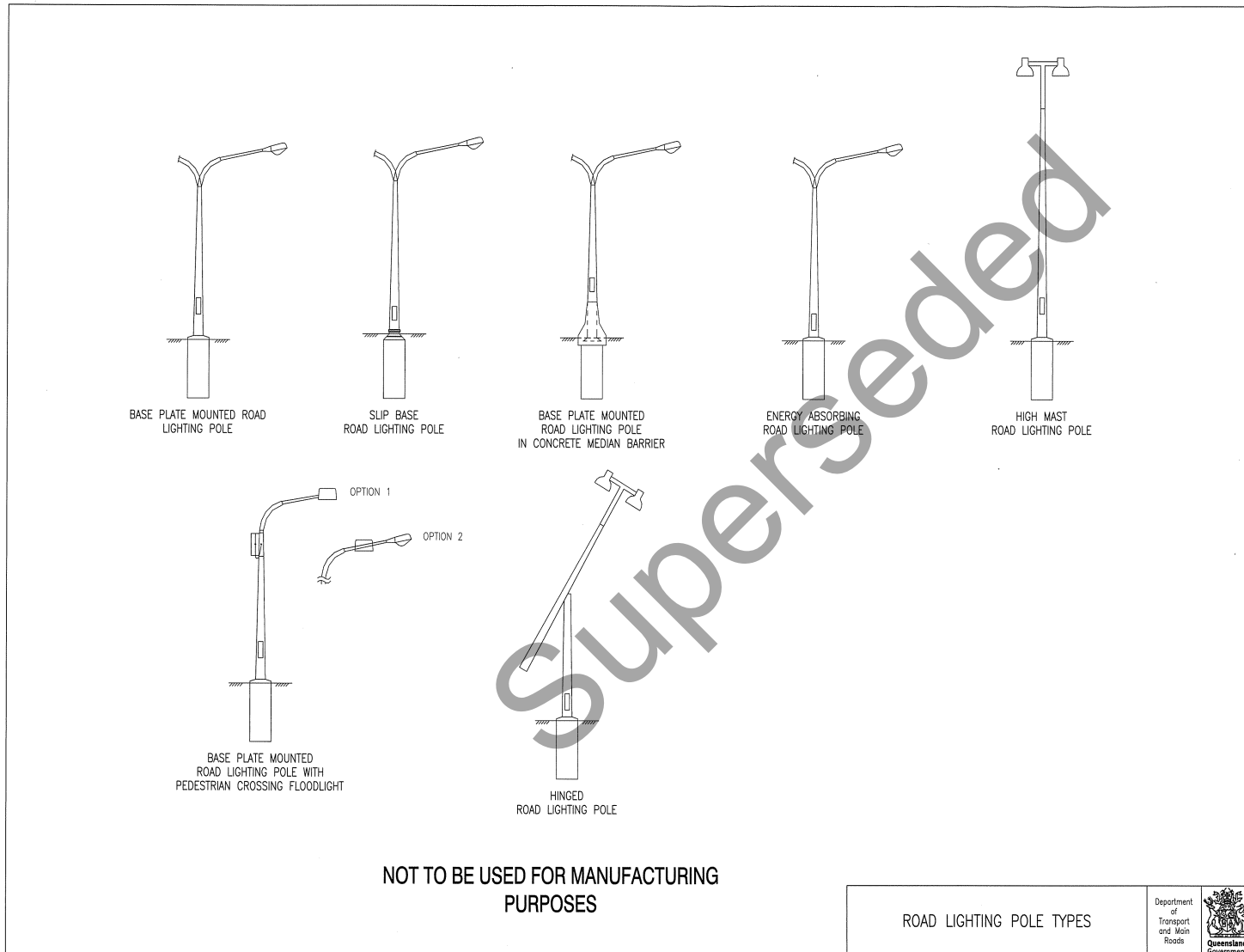

Figure 2 - Road lighting pole outreach arm and outreach arm extension

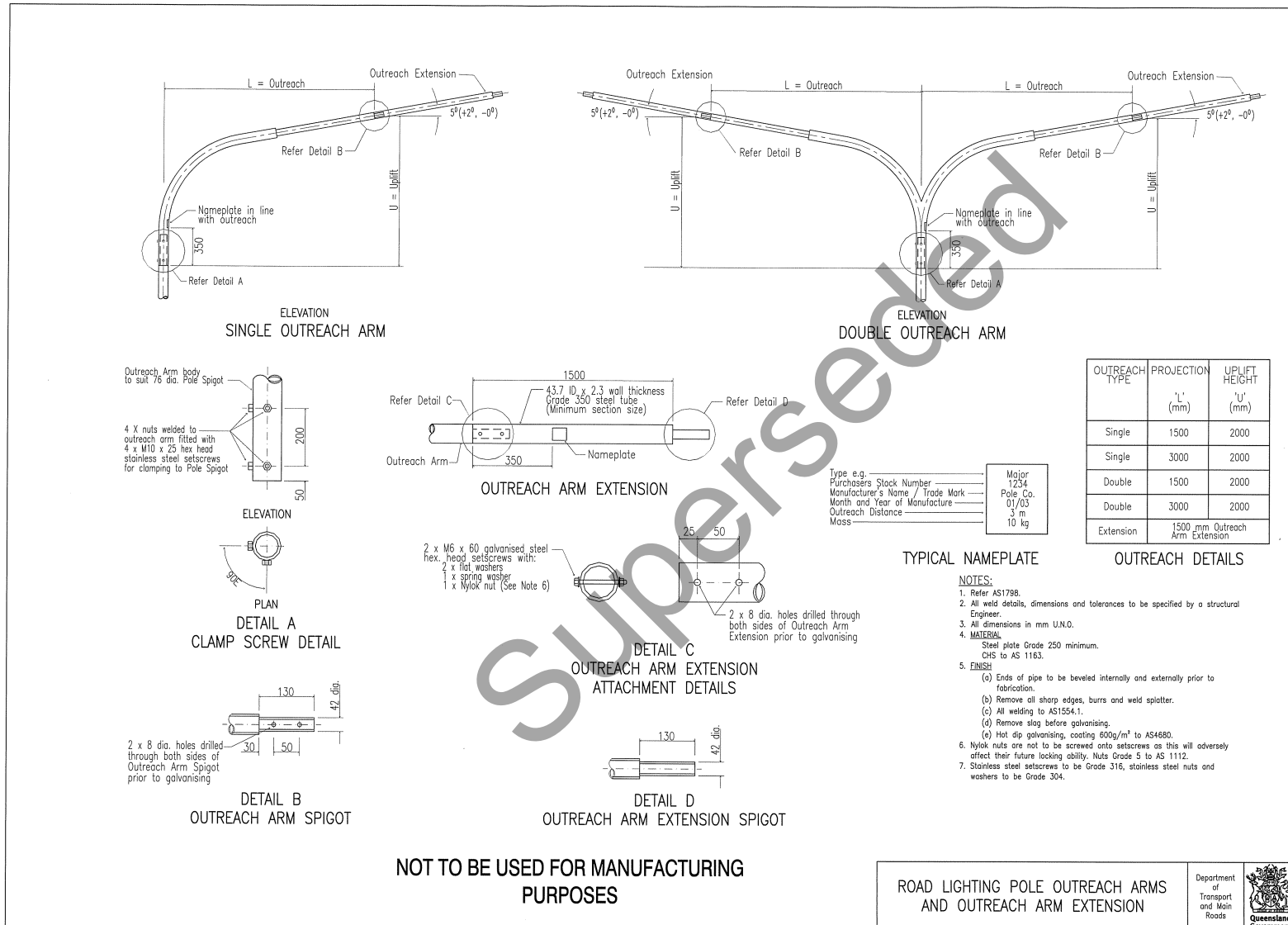

Figure 3 - Road lighting pole luminaire headframe

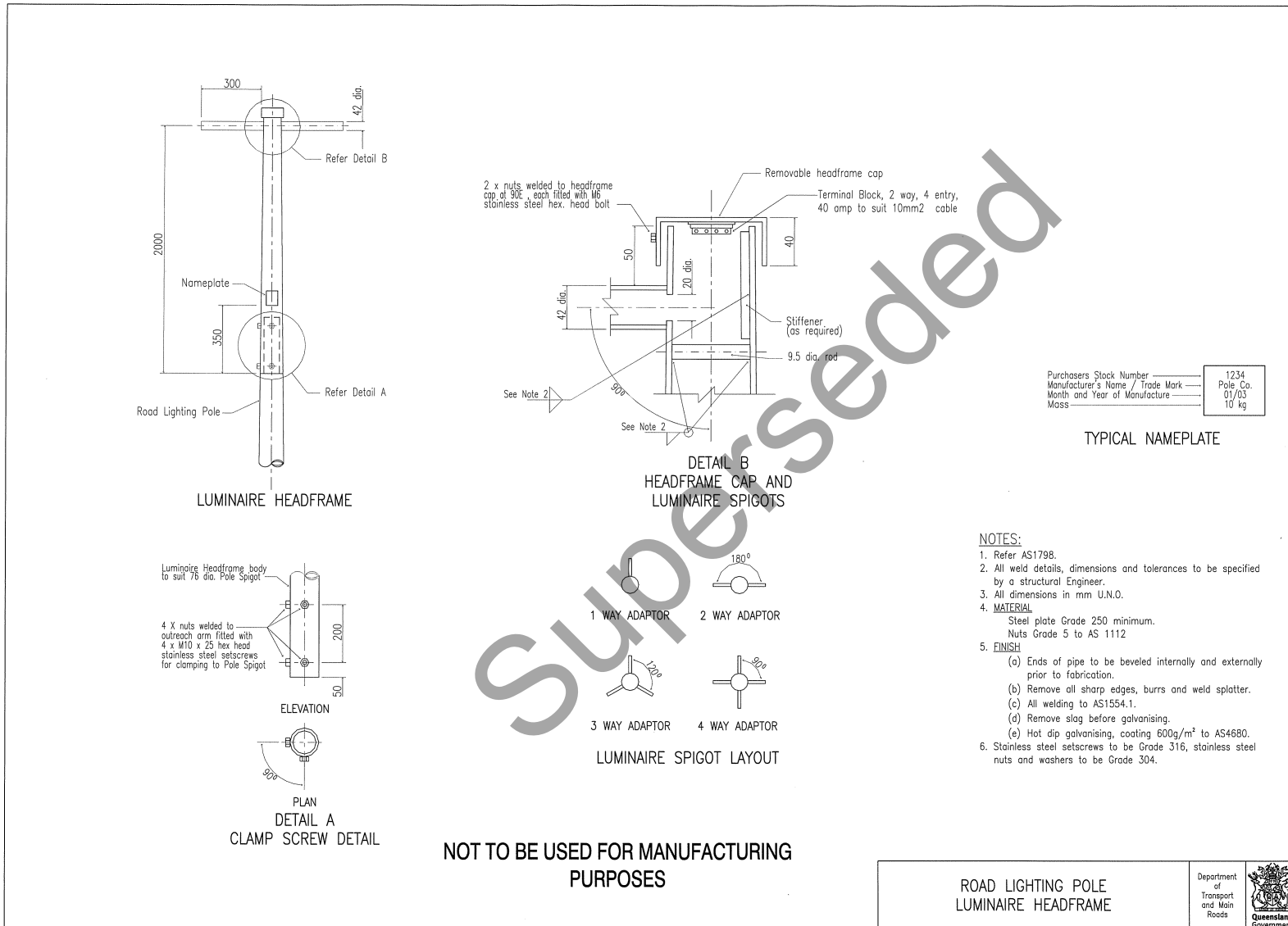

Figure 4 - Base plate mounted road lighting pole and joint use traffic signal and road lighting pole general arrangement – Sheet 1

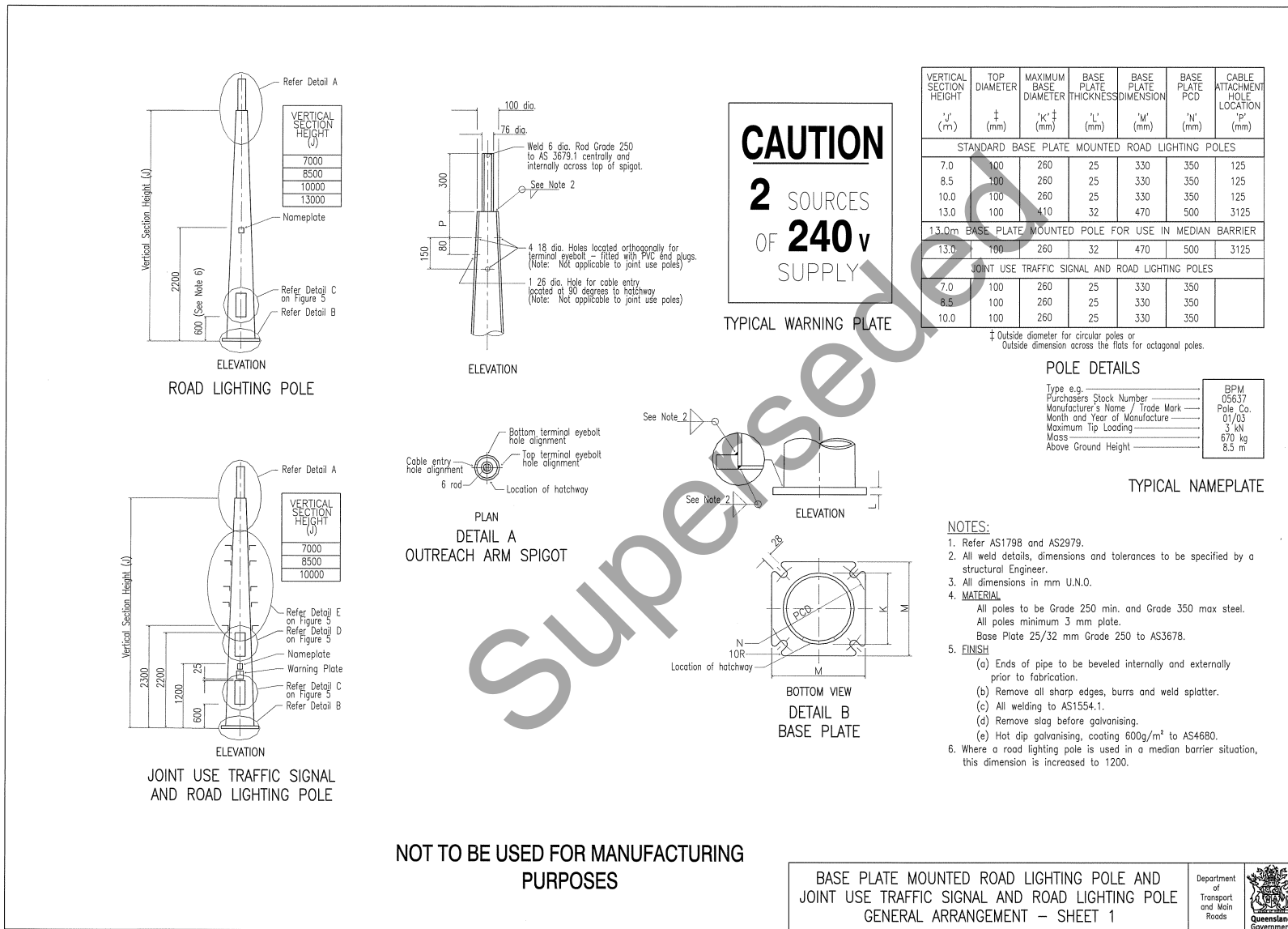

Figure 5 - Base plate mounted road lighting pole and joint use traffic signal and road lighting pole general arrangement – Sheet 2

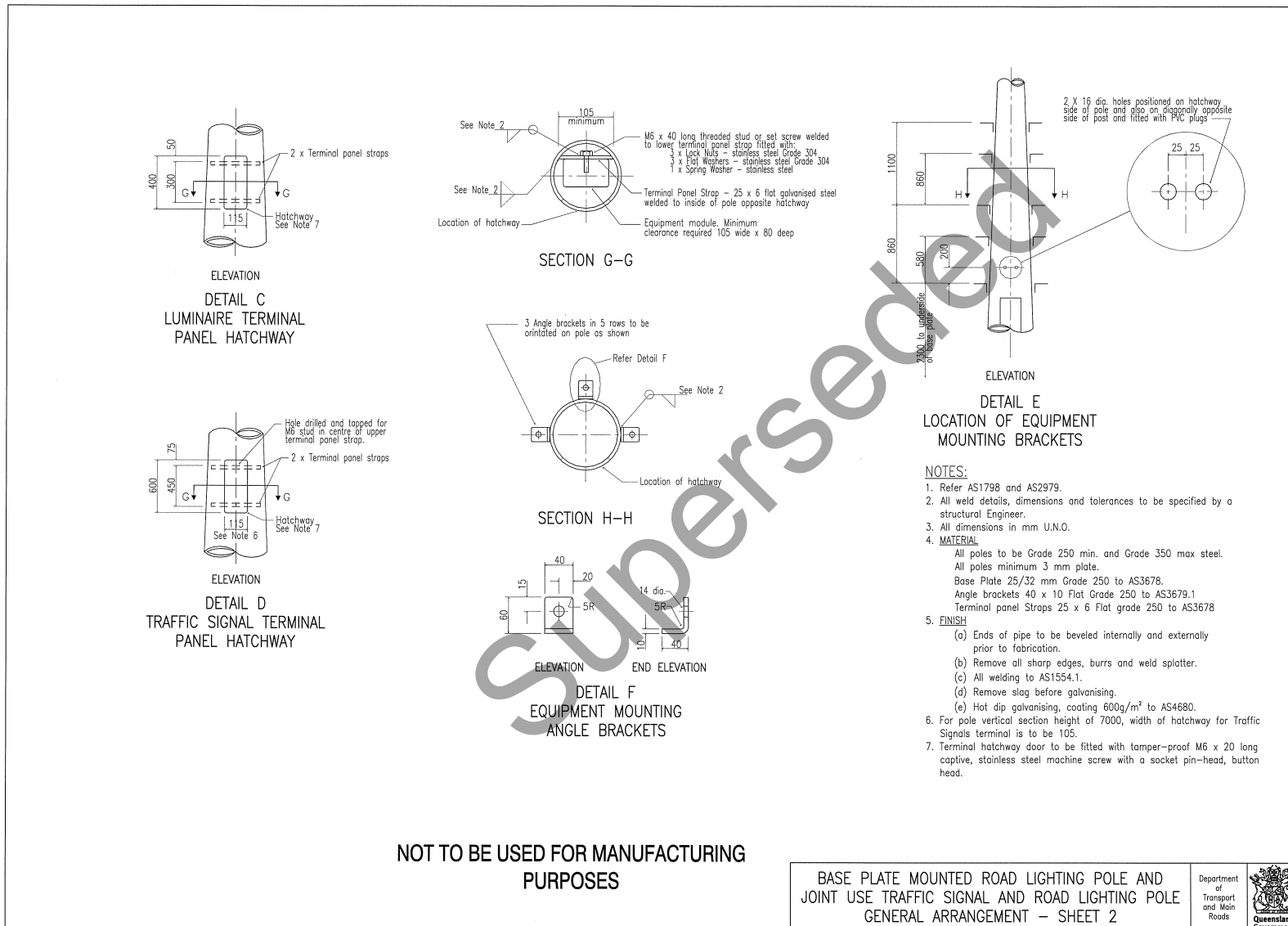

Figure 6 - Slip base road lighting pole general arrangement – Sheet 1

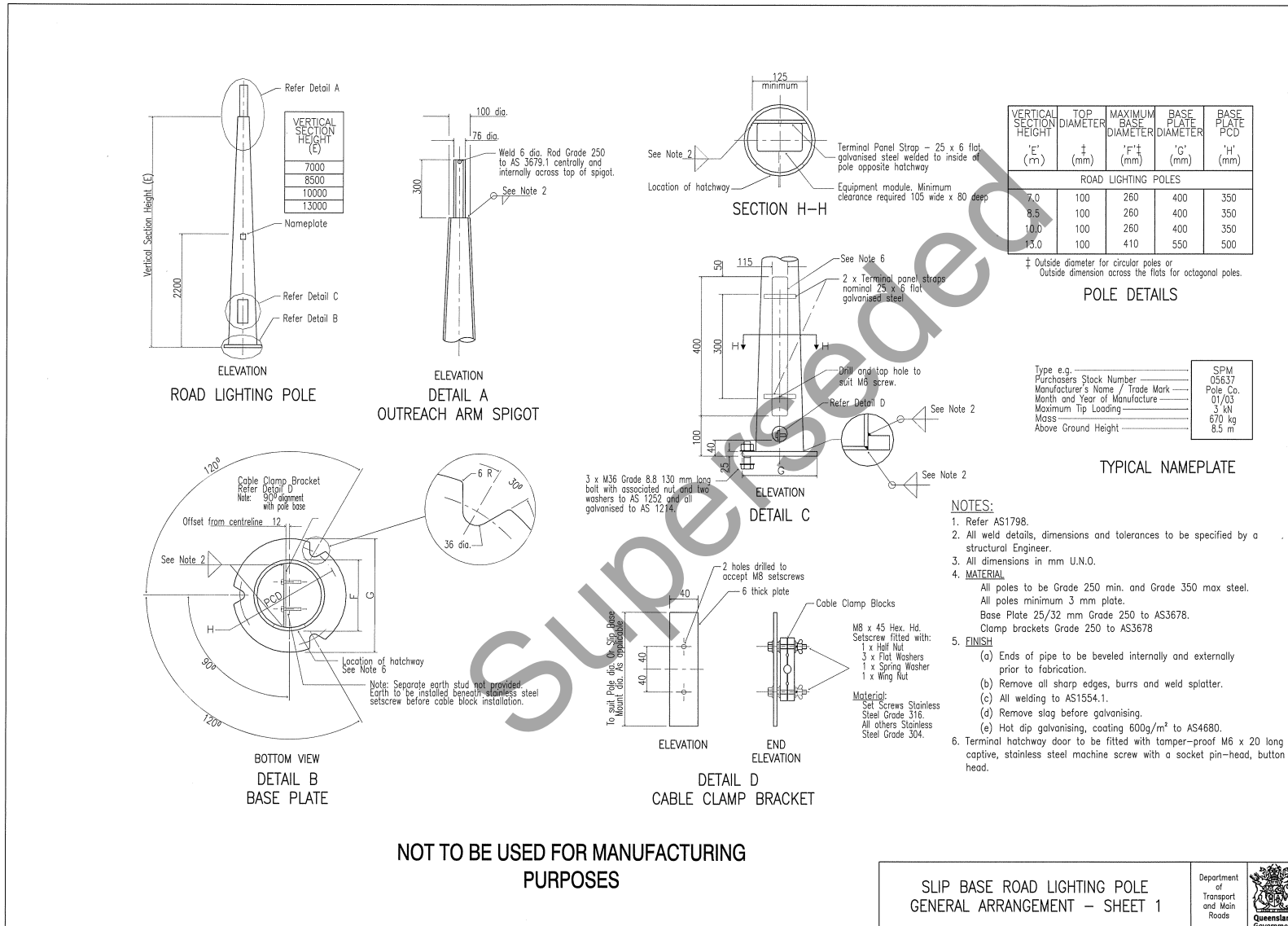

Figure 7 - Slip base road lighting pole general arrangement – Sheet 2



Figure 8 - Energy absorbing road lighting pole general arrangement

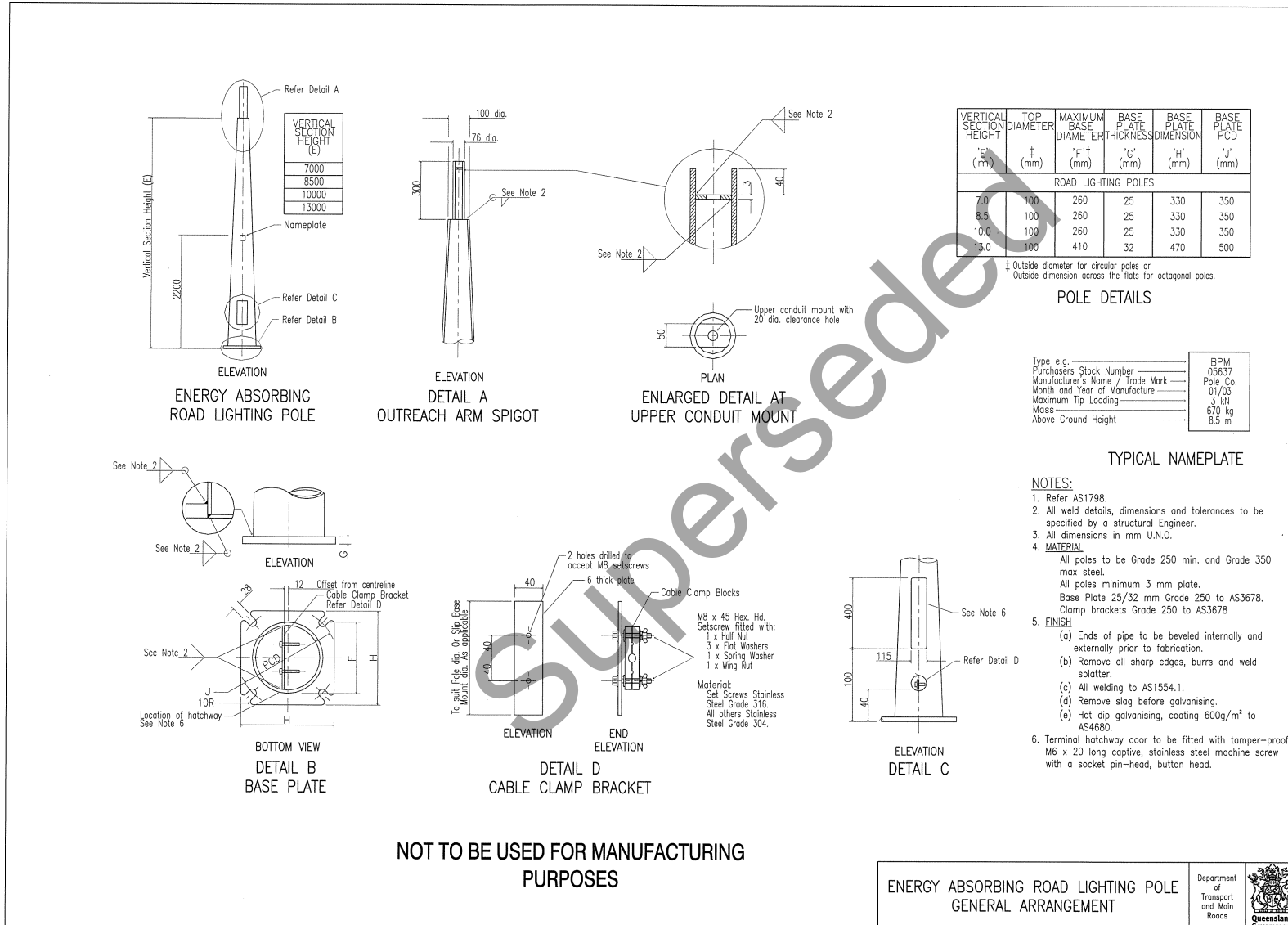

Figure 9 - Base plate mounted hinged road lighting pole general arrangement

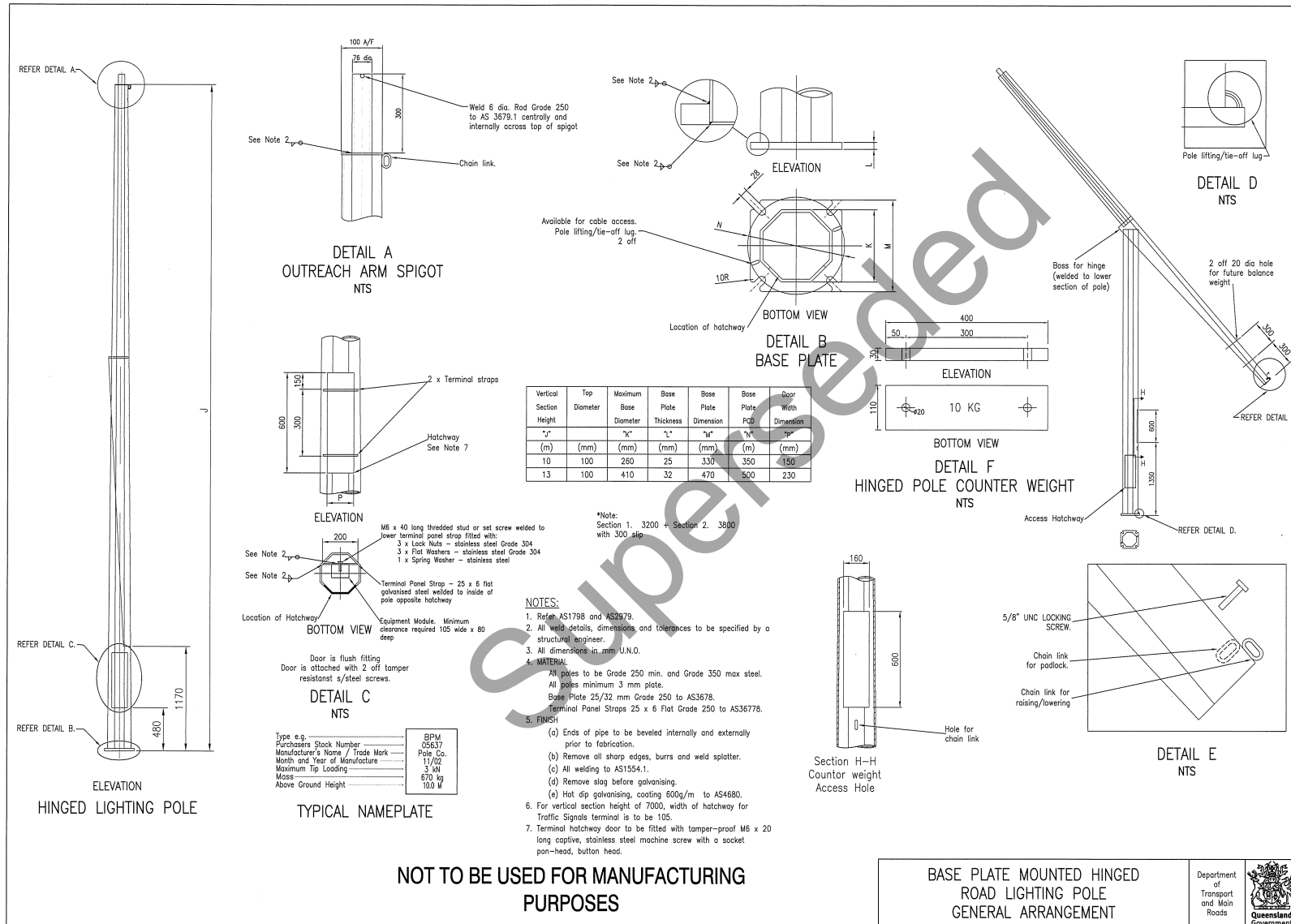

Figure 10 - Solar road lighting pole general arrangement

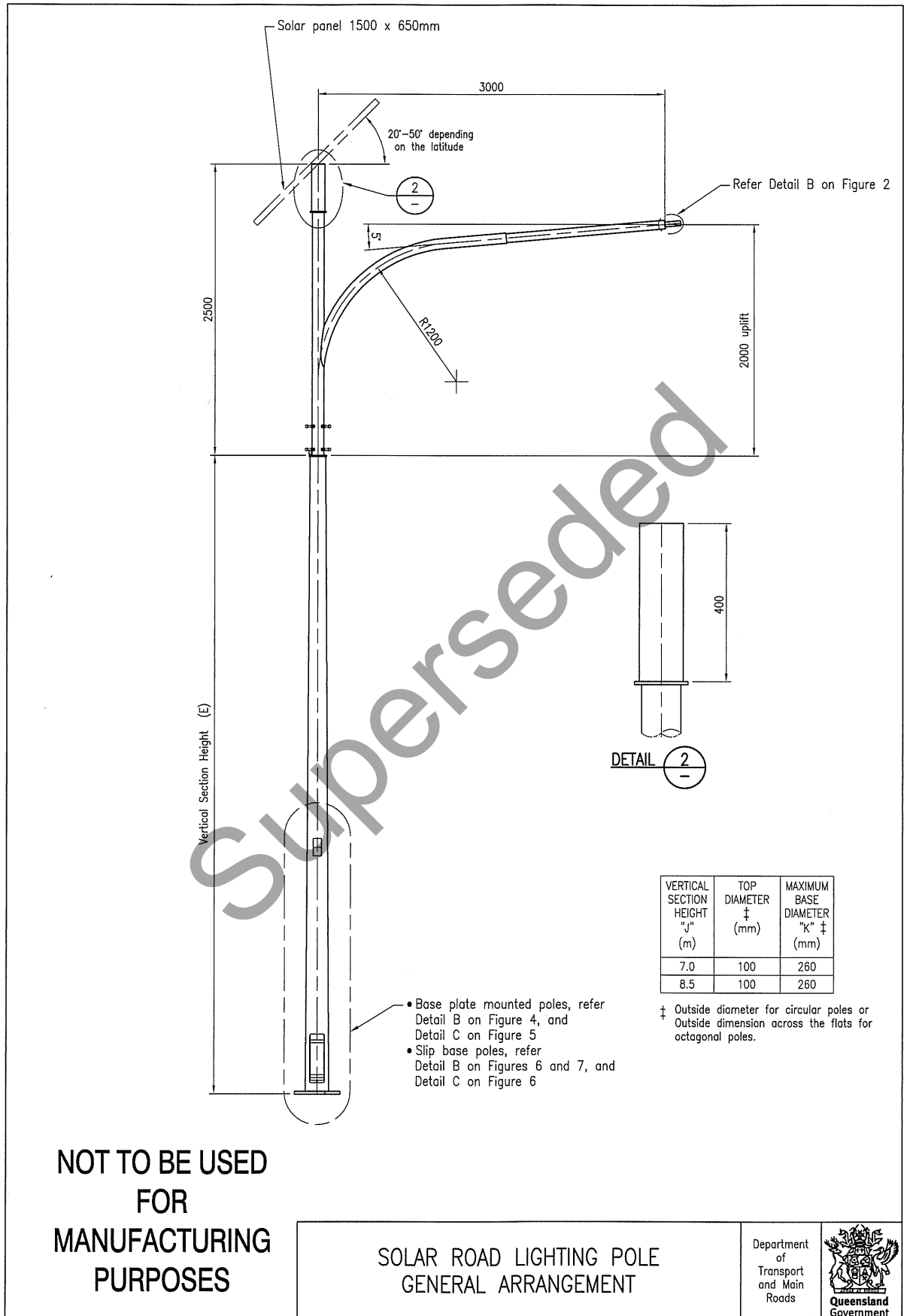

Figure 11 - Solar pathway lighting pole general arrangement

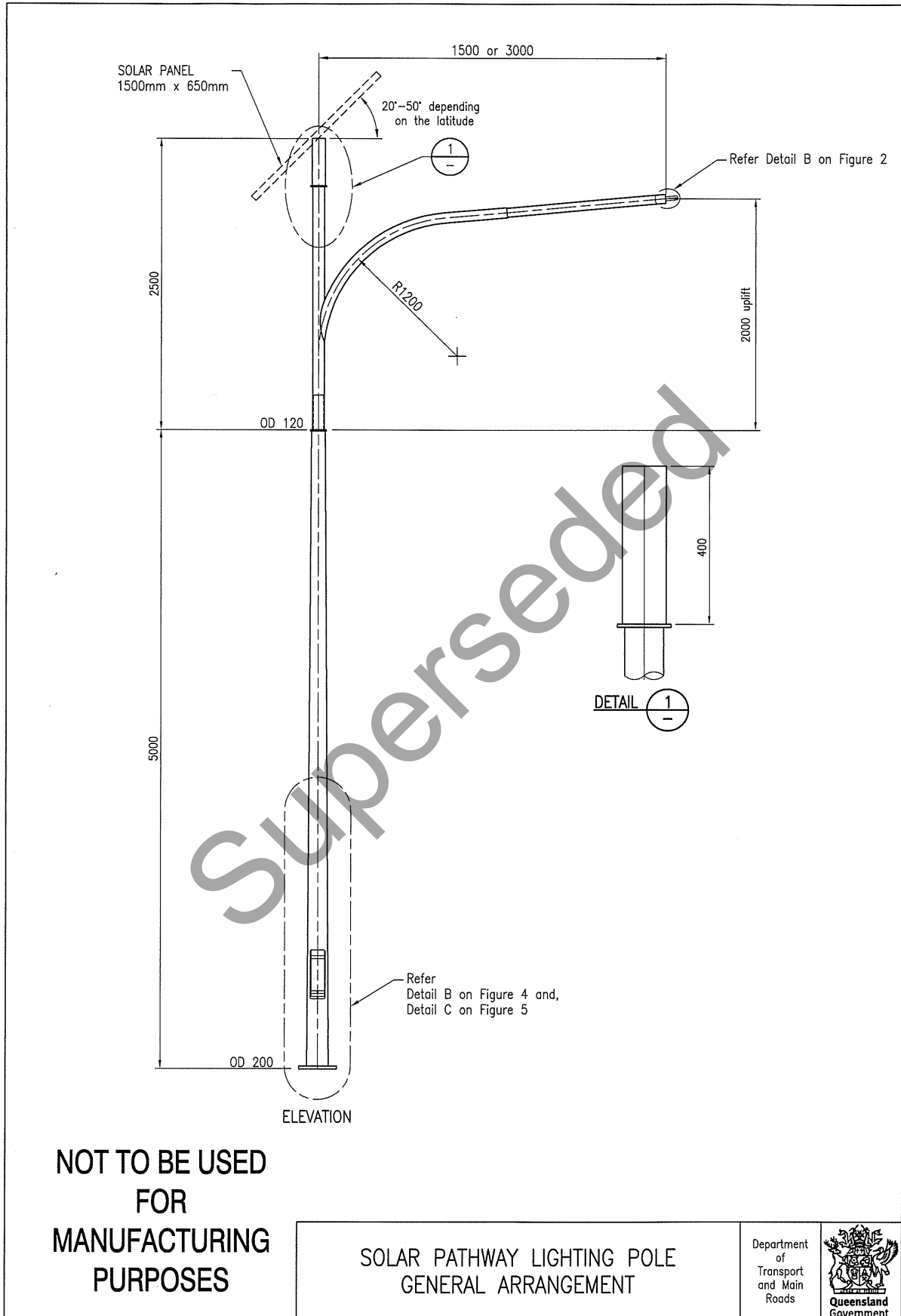

Figure 12 - Base mounted traffic signal post fabrication details

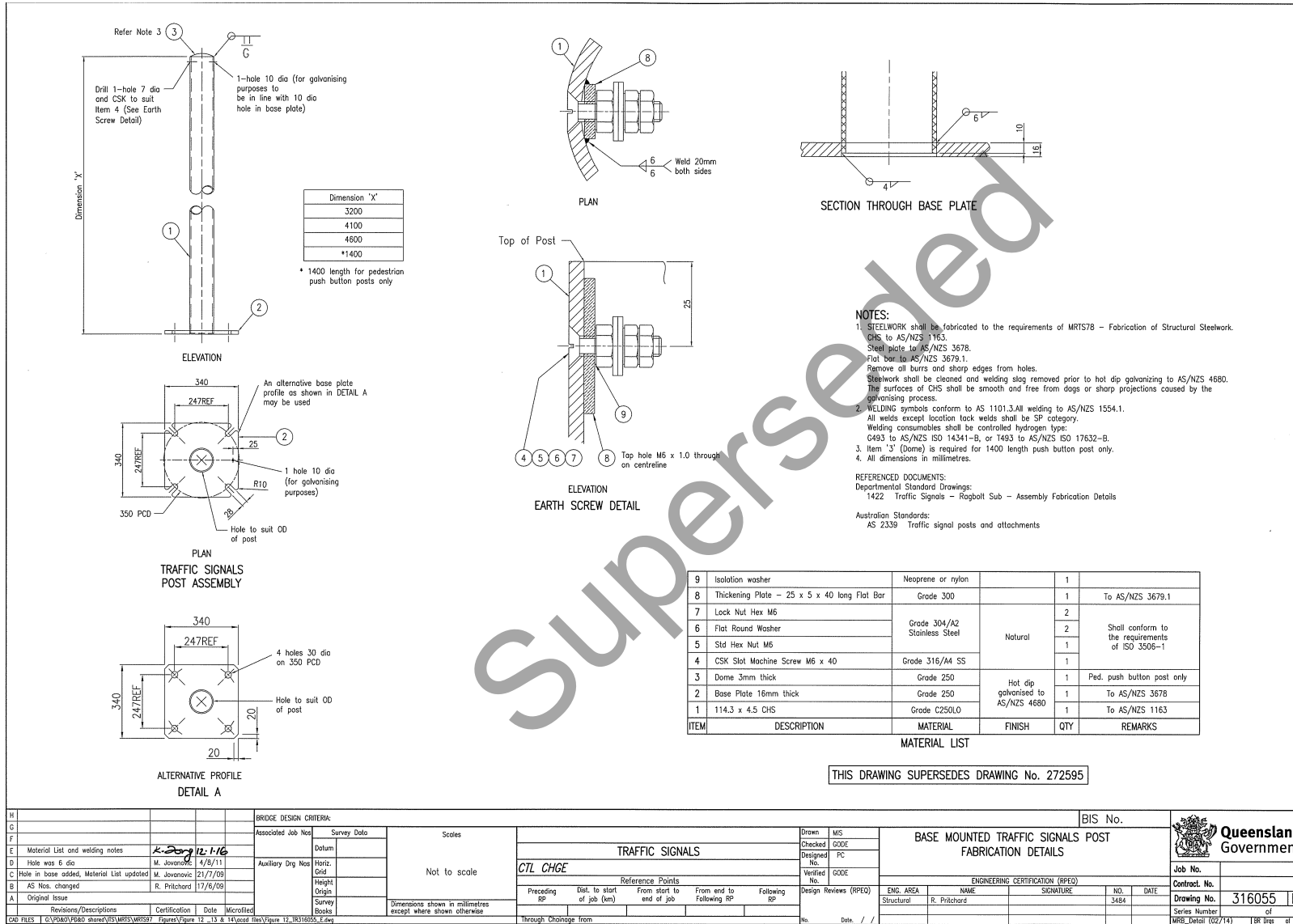

Figure 13 - Mast arm and luminaire transition general assembly

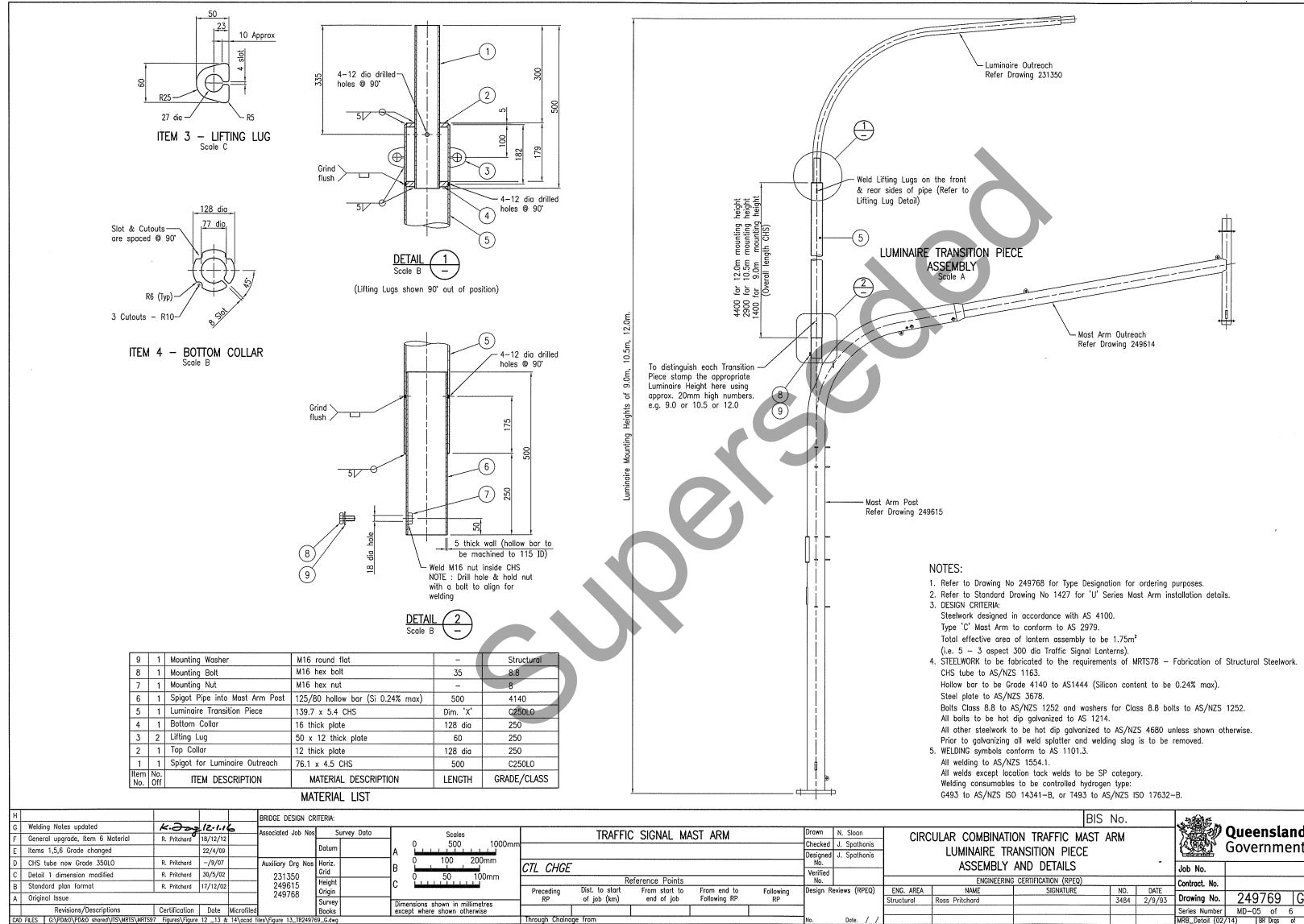

Figure 14 - Traffic mast arm type U2 assembly

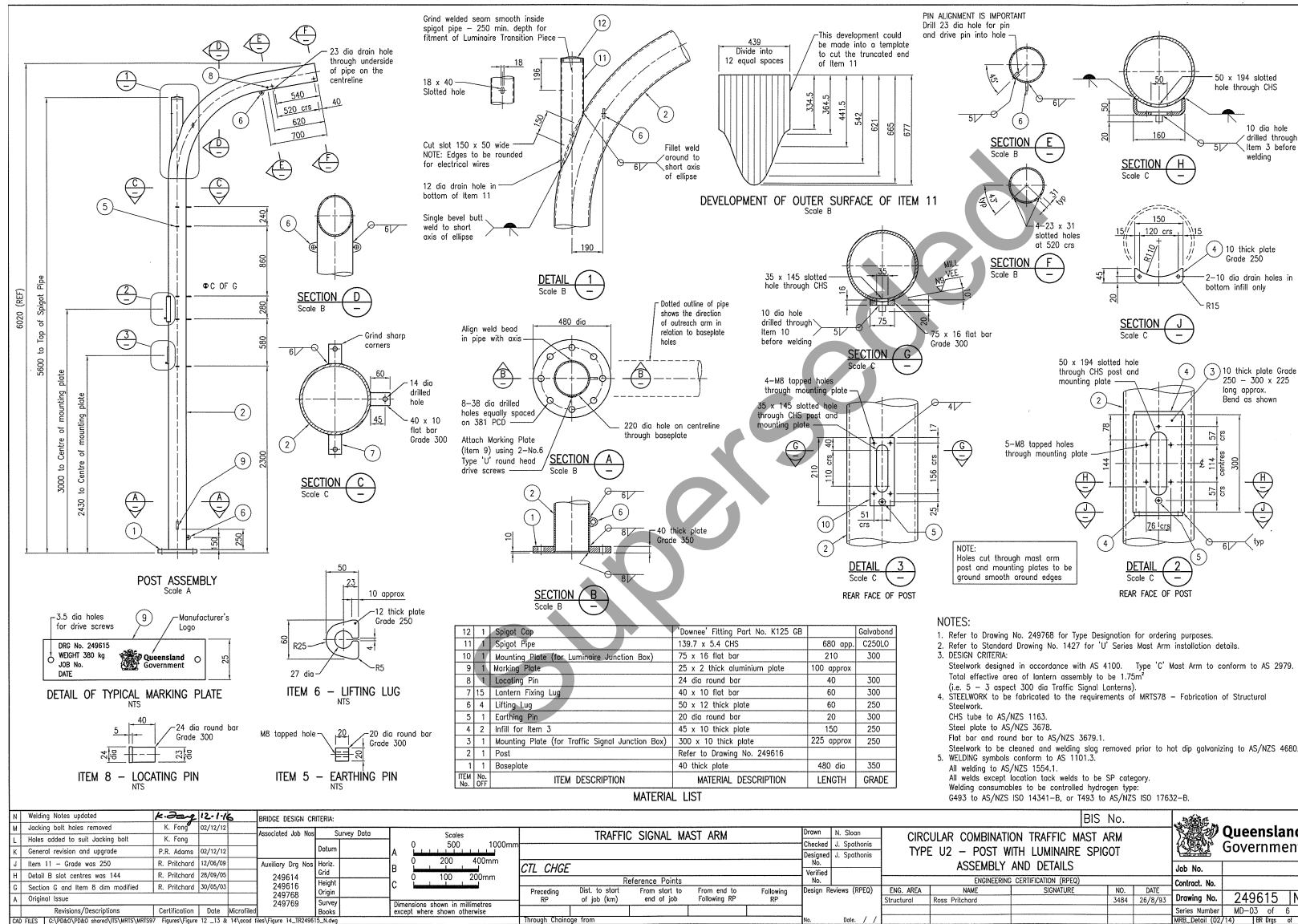

Figure 15 - CCTV camera mounting adaptor on traffic signal mast arm outreach general assembly and details

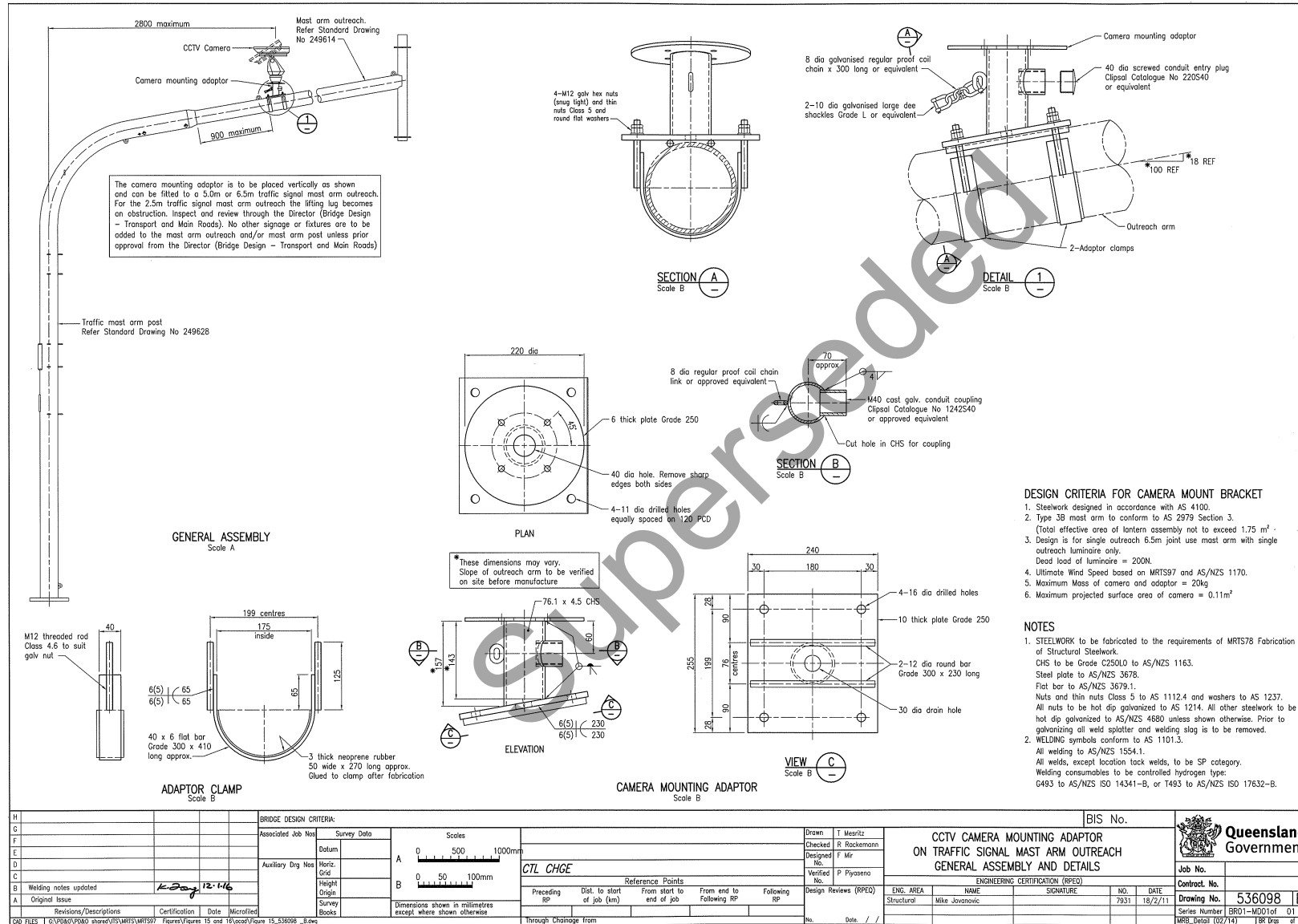

Figure 16 - CCTV camera post on traffic signal mast arm post general assembly and details

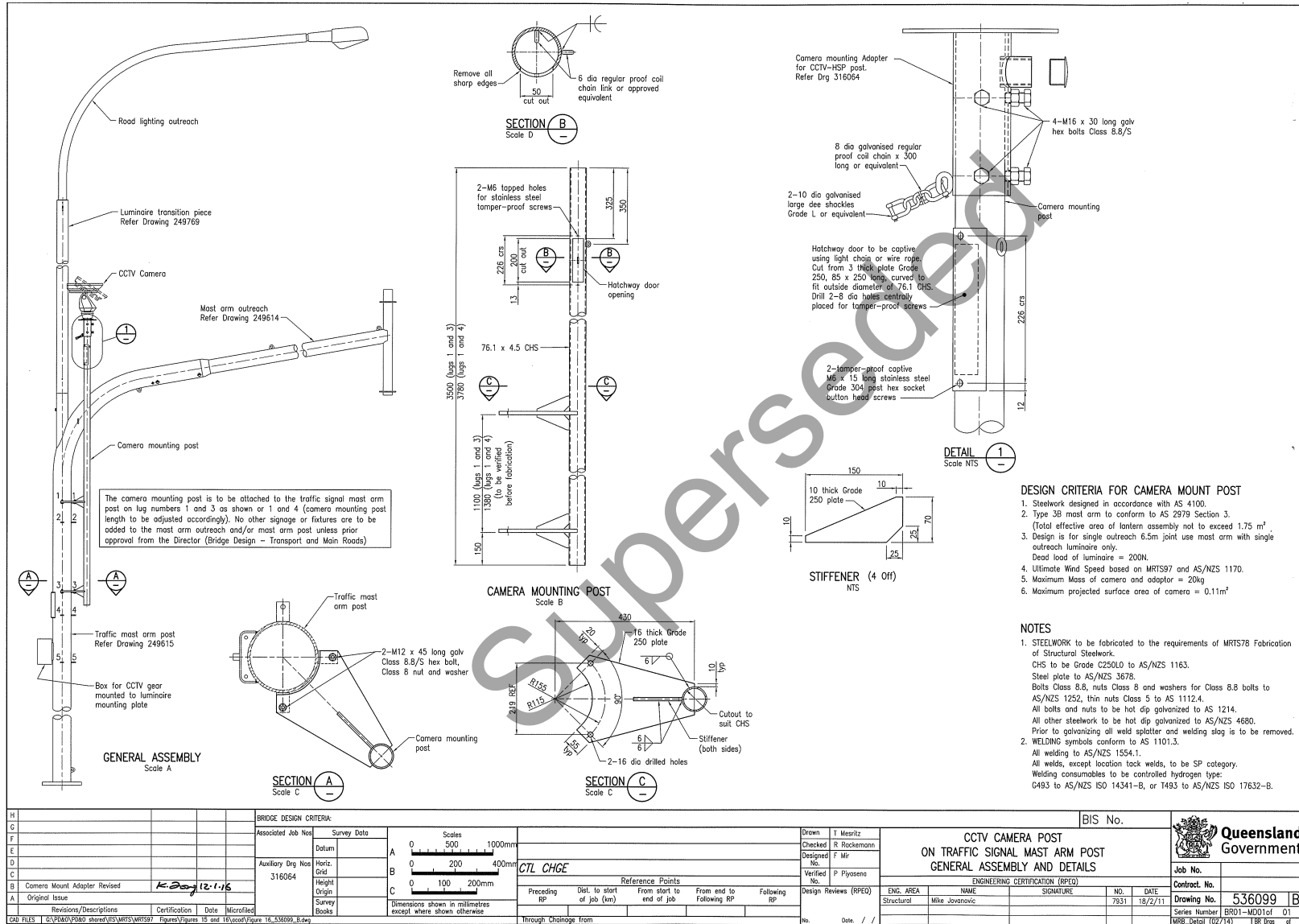

Figure 17 - Camera mounting adaptor for CCTV-HSP

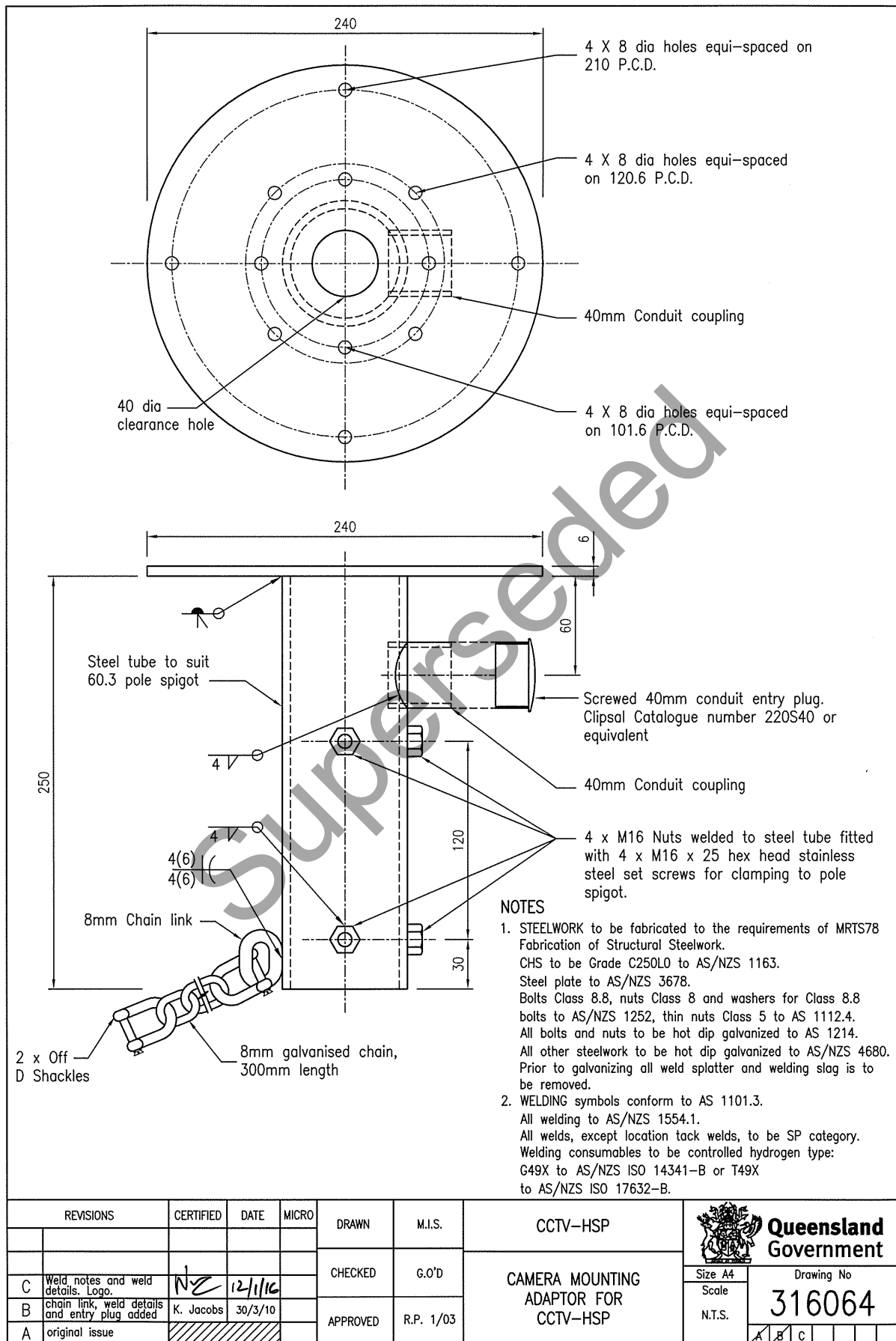
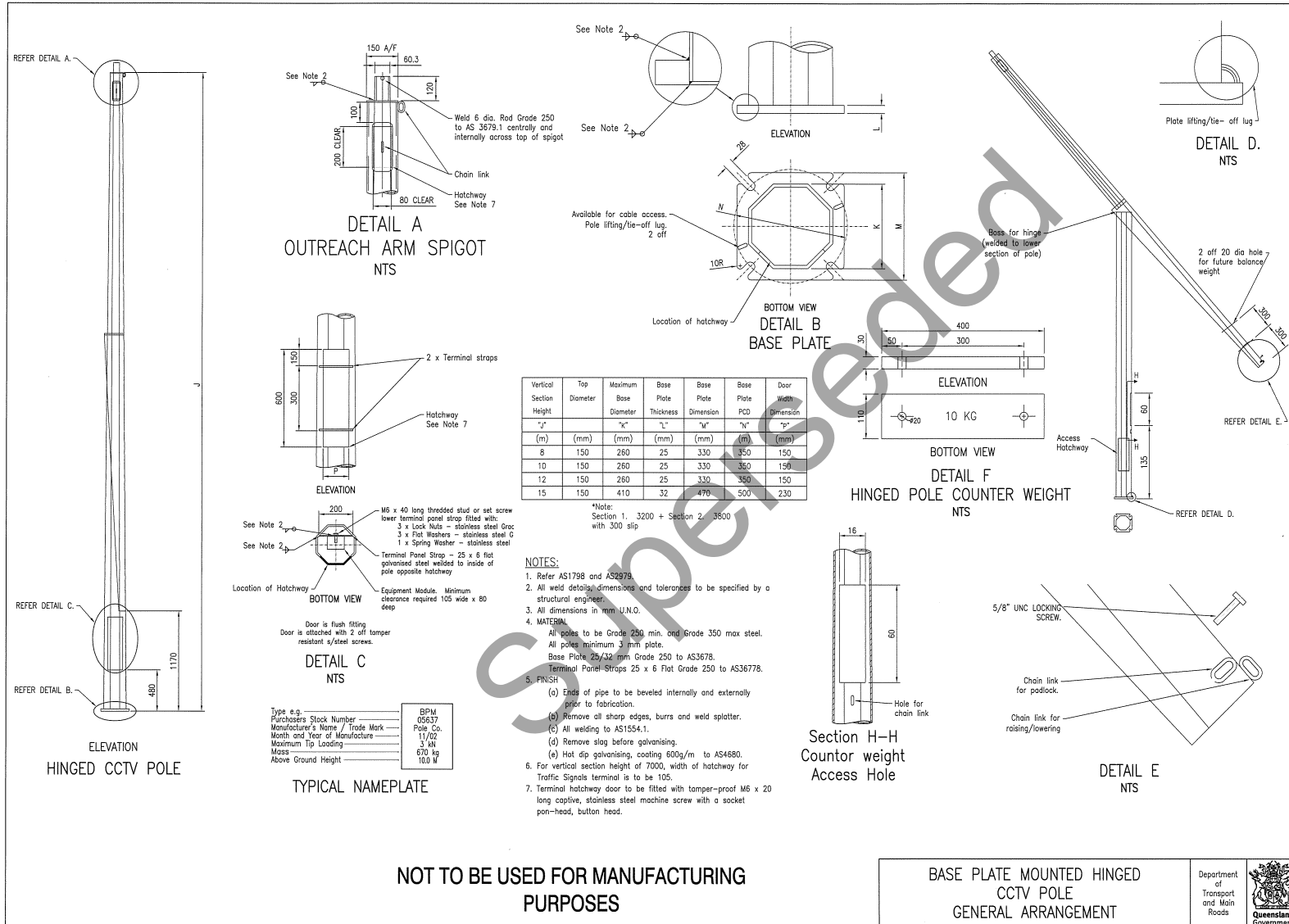

Figure 18 - Base plate mounted hinged CCTV pole general assembly



Superseded