

Superseded

Technical Specification

**Transport and Main Roads Specifications
MRTS09 Plant-Mixed Pavement Layers Stabilised using
Foamed Bitumen**

January 2017

Superseded

Copyright



<http://creativecommons.org/licenses/by/3.0/au/>

© State of Queensland (Department of Transport and Main Roads) 2017

Feedback: Please send your feedback regarding this document to: tmr.techdocs@tmr.qld.gov.au

Contents

1	Introduction	1
1.1	Bituminous surfacing and curing coats.....	1
2	Definition of terms	1
3	Referenced documents	3
4	Standard test methods	4
5	Quality system requirements	5
5.1	Hold Points, Witness Points and Milestones.....	5
5.2	Construction procedures.....	6
5.3	Conformance requirements.....	9
5.4	Testing frequencies and lot sizes.....	9
6	Material	10
6.1	Material(s) to be stabilised.....	10
6.1.1	<i>Use of materials</i>	10
6.1.2	<i>Material types</i>	11
6.2	Stabilising agents.....	12
6.3	Water.....	13
6.4	Foaming agent.....	13
6.5	Reclaimed Asphalt Pavement (RAP).....	13
6.6	Stockpiling of materials.....	14
7	Material compliance testing	14
7.1	Stabilising agents and water.....	15
7.2	UM1, UM2 or UM3 material(s).....	15
7.3	Stabilised materials.....	15
7.3.1	<i>Laboratory trial</i>	15
7.3.2	<i>Plant production trial</i>	15
8	Construction	16
8.1	Equipment.....	16
8.1.1	<i>Equipment requirements</i>	16
8.2	Program of works.....	18
8.3	Site, services, utilities buildings and drainage.....	19
8.4	Allowable time for placement, compaction and trimming.....	19
8.5	Allowable stockpile time.....	19
8.6	Allowable working time.....	19
8.7	Construction process.....	19
8.7.1	<i>General</i>	19
8.7.2	<i>Construction based on process requirements</i>	20
8.7.3	<i>Construction based on product standards</i>	20
8.8	Process requirements.....	20
8.8.1	<i>Methodology</i>	20
8.8.2	<i>Trial section</i>	20
8.9	Construction requirements.....	21

8.9.1	Reclaiming and processing existing pavement materials	21
8.9.2	Milling	21
8.9.3	Processing of reclaimed and/or RAP materials before mixing and stabilising	22
8.9.4	Transportation, storage and handling of stabilising agents	22
8.9.5	Foamed bitumen properties	22
8.9.6	Relative Moisture Ratio of Feed Stockpiles (RMR FSP)	22
8.9.7	Stockpiling of stabilised materials	24
8.9.8	Segregation	24
8.9.9	Preparation of surfaces	24
8.9.10	Layer thickness	27
8.9.11	Placement	28
8.9.12	Compaction	28
8.9.13	Trimming after compaction	28
8.9.14	Period for placement, compaction and trimming	29
8.9.15	Construction joints	29
8.9.16	Joining new work to existing pavements and structures	30
8.9.17	Requirement of trafficking on stabilised layer	30
8.9.18	Curing	30
8.9.19	Bituminous surfacing	30
8.9.20	Maintenance of the stabilised layer	30
8.9.21	Conditions under which stabilisation and placement shall not proceed	31
8.10	Product standards	31
8.10.1	Stabilising agent contents	31
8.10.2	Relative Moisture Ratio Foamed Bitumen (RMR FB)	32
8.10.3	Compaction standard	32
8.10.4	Geometrics	32
9	Construction compliance testing	34
9.1	Process requirements	34
9.2	Product standards	34
9.3	Geometrics	35
9.4	Bituminous stabilising agent content	35
9.5	Secondary stabilising agent content	36
9.6	Compaction	37
9.7	Visible deflection of pavement layers	38
9.8	Acceptance	38
10	Supplementary requirements	38

1 Introduction

This Technical Specification applies to the construction of stabilised layers in road pavements using a plant-mixed pavement material which comprises a mixture of unbound granular pavement material, foamed bitumen, and a secondary stabilising agent that is placed in a single layer with a thickness that is no less than 125 mm and no more than 250 mm.

This Technical Specification shall be read in conjunction with MRTS01 *Introduction to Technical Specifications*, MRTS50 *Specific Quality System Requirements* and other Technical Specifications as appropriate.

This Technical Specification forms part of the Transport and Main Roads Specifications Manual.

1.1 Bituminous surfacing and curing coats

Bituminous surfacing and curing coats shall be a sprayed bituminous surfacing with cover aggregate and shall comply with MRTS11 *Sprayed Bituminous Surfacing (Excluding Emulsion)*, MRTS12 *Sprayed Bituminous Emulsion Surfacing*, MRTS17 *Bitumen*, MRTS20 *Cutback Bitumen*, MRTS21 *Bituminous Emulsion*, MRTS22 *Supply of Cover Aggregate* and other relevant Technical Specifications.

Notwithstanding the above bituminous curing coats shall also comply with this Technical Specification and the requirements of this Technical Specification take precedence.

2 Definition of terms

The terms used in this Technical Specification shall be as defined in Clause 2 of MRTS01 *Introduction to Technical Specifications*. Further terms are defined as set out in Table 2.

Table 2 – Definition of terms

Term	Definition	Clause Reference
Allowable time for placement, compaction and trimming	The time within which placement, compaction and trimming of the stabilised material/layer shall be completed. It shall be the difference between the allowable working time and the allowable stockpile time.	8.4
Allowable stockpile time	The maximum time that the stabilised material shall be stockpiled, measured from the commencement of incorporation of the stabilising agent added (i.e. mixing of the stabilisation agent added into the material to be stabilised) to when it is first removed from its original stockpile.	8.5
Allowable working time	The time within which compaction and trimming of the stabilised layer shall be completed, measured from the commencement of incorporation of stabilising agent added (i.e. mixing of the stabilisation agent into the material) to completion of compaction and trimming of the stabilised material/layer.	8.6
Available lime index	The available calcium oxide for quicklime or available calcium hydroxide for hydrated lime in accordance with AS 4489.6.1.	6.2

Term	Definition	Clause Reference
Base course	A course or courses principally intended to directly support the traffic loads.	6.1.2
Bitumen	Class 170 bitumen that complies with MRTS17 <i>Bitumen</i> .	Table 6.2
Bound layer	Existing asphalt or previously stabilised pavement layer.	8.9.9
Curing materials	Materials applied to the exposed surfaces of the completed stabilised layer for the purpose of curing.	8.9.18
ESA (Equivalent Standard Axles)	Equivalent Standard Axles. Standard Axles is a single axle with dual wheels loaded to a total mass of 8.2 tonne (80 kN) and with tyres inflated to a pressure of 750 kPa.	6.1.1
Expansion ratio	A term used to define the expansion properties of the bituminous stabilising agent. It is defined as the ratio of the maximum volume of the bitumen in its foamed state to the volume of bitumen once the foaming has completely subsided.	5.4 & 8.9.5
Feed stockpile	Stockpile of Type UM1, UM2, or UM3 material to be fed in mixing plant for stabilisation.	6.1
Foamed bitumen	Class 170 bitumen which is temporarily brought into a foamed state by the addition of water and foaming agent(s).	1 & 8.9.5
Foaming agent	A chemical additive added to bitumen to improve its foaming characteristics.	6.4
Foaming properties	The expansion ratio and half-life of the bituminous stabilising agent.	8.9.5
Half life	A term used to define the expansion properties of the bituminous stabilising agent. It is defined as the time taken for the foamed bitumen to settle to one half of the maximum volume of the bitumen in its foamed state. It is measured from the start of bitumen foaming.	5.4 & 8.9.5
Hydrated Lime	It is included in the stabilisation process to improve the dispersion of the foamed bitumen and increase the early strength of the stabilised material. Hydrated Lime is a granular form of lime consisting primarily of calcium hydroxide (Ca(OH) ₂).	6.2 & Table 6.2
Plant mixed material	Material mixed in specialised, dedicated equipment that complies with this Technical Specification.	1 & 8.1.1.2
Relative Moisture Ratio (RMR)	The ratio of the moisture content of a material compared to the optimum moisture content, expressed as a percentage. The relative moisture content is determined by Test Method Q140A for compacted materials and Test Method Q250 for uncompacted materials.	8.9.2 & 8.9.6
Relative Moisture Ratio Feedstock (RMR FSP)	The relative moisture content of the crushed granular materials (UM1 to UM3) in feed stockpile prior to incorporation of stabilising agents.	8.9.6

Term	Definition	Clause Reference
Relative Moisture Ratio Foamed Bitumen (RMR FB)	The relative moisture content of the foamed bitumen treated granular material.	8.9.6 & 8.10.2
Reclaimed asphalt pavement (RAP)	Asphalt that has been milled or excavated from existing asphalt pavements, or returned from job sites.	6.5
Reclaimed materials	Unbound gravel that has been milled or excavated from existing pavement from job site and screened which could be reincorporated into the foamed bitumen stabilisation process.	6.1.2
Secondary stabilising agent	Hydrated lime or blended hydrated lime with fly ash included in the stabilisation.	Table 5.4 & 6.2
Secondary weighing system	In lieu of weighbridge, alternative weighing option such as a loader bucket with a calibrated load cell.	5.2
Stabilising agents	Foamed bitumen, hydrated lime and/or blended hydrated lime with fly ash.	6.2
Type UM1 material	Unbound material that conforms to the requirements for Type 2.1, 2.2, 2.3 material with a 'C' grading as specified in MRTS05 <i>Unbound Pavements</i> and to this Technical Specification. It shall comprise virgin quarried and/or reclaimed material.	6.1.1 & 6.1.2
Type UM2 material	Unbound material that incorporates up to 10% RAP and that conforms to the requirements for Type 2.2 material with a 'C' grading as specified in MRTS05 <i>Unbound Pavements</i> and to this Technical Specification. It shall comprise virgin quarried, reclaimed and/or RAP material but shall not include more than 15% RAP.	6.1.1 & 6.1.2
Type UM3 material	Unbound material that incorporates up to 10% RAP and that conforms to the requirements for Type 2.3 material as specified in MRTS05 <i>Unbound Pavements</i> and to this Technical Specification. It shall comprise virgin quarried, reclaimed and/or RAP material but shall not include more than 15% RAP.	6.1.1 & 6.1.2

3 Referenced documents

Table 3 lists documents referenced in this Technical Specification.

Table 3 – Referenced documents

Reference	Title
AP-G41/02	Austrroads' Bitumen Sealing Safety Guide (2nd Edition)
AP-G41/08	Austrroads' Bituminous Materials Safety Guide
AS 2891.13.1	Methods of sampling and testing asphalt – determination of the resilient modulus of asphalt – Indirect tensile method
AS 4489.6.1	Test methods for limes and limestones – Lime index – Available lime
AS 3582.1	Supplementary Cementitious Materials for Use with Portland Cement: Fly Ash
MRTS01	Introduction to Technical Specifications

Reference	Title
MRTS05	Unbound Pavements
MRTS08	Plant-Mixed Stabilised Pavements using Cement or Cementitious Blends
MRTS11	Sprayed Bituminous Surfacing (Excluding Emulsion)
MRTS12	Sprayed Bituminous Emulsion Surfacing
MRTS17	Bitumen
MRTS20	Cutback Bitumen
MRTS21	Bituminous Emulsion
MRTS22	Supply of Cover Aggregate
MRTS23	Supply and Delivery of Quicklime and Hydrated Lime for Road Stabilisation
MRTS30	Asphalt Pavements
MRTS50	Specific Quality System Requirements
Transport and Main Roads Technical Note 150	Testing of Materials for Foamed Bitumen Stabilisation

4 Standard test methods

The standard test methods listed in Table 4 shall be used in this Technical Specification, subject to the method of application(s) stated below.

Further details of test numbers and test descriptions are given in Clause 4 of MRTS01 *Introduction to Technical Specifications*. For compliance testing requirements, refer to Clauses 7 and 9.

Table 4 – Standard test methods

Property to be Tested	Test Method Number
Determination of the relationship between standard and subsidiary test methods	Q010
Laboratory Reference Density	Q142A, Q144A
Relative compaction	Q140A, Q141A, Q141B
Moisture content	Q102A, Q102B, Q102D, Q141A
Relative moisture content	Q250
Particle size distribution	Q103A
Preparation of disturbed samples	Q101
Liquid Limit	Q104A
Plastic Limit and Plasticity Index of soil	Q105
Linear Shrinkage	Q106
Ten Percent Fines	Q205B
Degradation Factor	Q208B
Flakiness Index	Q201
California Bearing Ratio	Q113A

Property to be Tested	Test Method Number
Determination of the resilient modulus of foamed bitumen stabilised material	Q139
Sampling of Soils, Crushed Rock and Aggregates	Q060
Selection of sampling and test locations	Q050
Spot Sampling of Soils, Crushed Rock and Aggregates	Q061
Bitumen Content of Bitumen Stabilised Materials	Q118
Lime Content of Lime Treated Materials	Q117A
Sulphate content	Q131A
Road Roughness-Surface evenness	Q708B, Q708C, Q708D
Relative moisture ratio	Q250

5 Quality system requirements

5.1 Hold Points, Witness Points and Milestones

General requirements for Hold Points, Witness Points and Milestones are specified in Clause 5.2 of MRTS01 *Introduction to Technical Specifications*.

The Hold Points, Witness Points and Milestones applicable to this Technical Specification are summarised in Table 5.1.

Table 5.1 – Hold Points, Witness Points and Milestones

Clause	Hold Point	Witness Point	Milestone
5.2	1. Approval of construction procedures and construction program. Acceptance of proposed materials sources. Acceptance of results of all tests undertaken by the Contractor including foamed bitumen stabilised material as per Transport and Main Roads Technical Note 150.		Supply of the construction procedures and construction program for the stabilisation works (21 days). Submission of samples of materials and all test results to Administrator (21 days).
6.6		All stockpiles including feed stockpile prior to incorporation of the stabilising agents.	
7	2. All materials including stabilising agents must comply prior to their incorporation.		
8	3. Construction permitted to proceed.		

Clause	Hold Point	Witness Point	Milestone
8.1.1.4	4. Self-propelled spreading machine trial (if paver is used).		
8.3	5. Survey of services, utilities buildings and drainage completed and submitted to Administrator.		
8.8.1	6. Approval of compaction based on a process requirement (if process standard specified).		
8.8.2		Construction of trial section (if process standard is specified).	
8.9.5	7. Foaming properties of bituminous stabilising agent comply.		
8.9.9		Preparation of surface.	
8.9.9.1.1	8. Extent of crack filling.		
8.9.9.1.2	9. Extent of stain alleviating geotextile strips.		
8.10.1.1			Notification of ordered content of stabilising agents (14 days).
9.7		Visible deflection of pavement layer.	
9.8	10. Acceptance.		

5.2 Construction procedures

The Contractor shall prepare documented procedures for all construction processes in accordance with Clause 6 of MRTS50 *Specific Quality System Requirements*. The construction procedure described in this Clause shall be submitted to the Administrator.

A construction procedure detailing all work described in this Technical Specification shall be prepared.

The construction procedure shall include, but not be limited to:

- a) Details of all plant/equipment associated with the work detailed in this Technical Specification.
- b) General maintenance plan for all plants including mixing equipment.
- c) Start-up procedure of mixing equipment including secondary agents and water supply point.
- d) Plant inspection schedule and recording sheet by operator (daily and/or weekly inspection).
- e) Details of how services, utilities, buildings and drainage components shall be located and/or protected from damage, injury, etc. (refer to Clause 8.3), and

f) Details of calibration procedures. Calibration of the production plant shall be undertaken at the start of production daily. The calibration procedure for the plant is described below but not limited to:

- i. Mixing equipment shall be warmed up approximately 10 minutes prior to undertaking calibration.
- ii. Batch a representative portion of the feed stockpile material (up to 50 tonnes) through the plant. Measure and record the net mass of the feed stockpile material discharged directly from the plant into the secondary weighing system. Follow the plant manufacturer's calibration procedures, entering the net weight of the discharged feed stockpile material into the plant's control system to adjust the calibration factor, and
- iii. Repeat step ii until the batched net weight of discharged feed stockpile material is within +/- 2.5% of the batch quantity entered into the plant's control system.

Note: For the calibration process, a weighbridge is the preferred weighing option, however where not available or not within close proximity of the production plant, a secondary weighing option may be utilised.

g) A detailed sequence of operations for all aspects of the stabilisation works, including, but not necessarily limited to:

- i. Location of the plant mixing and details of manufacturing process.
- ii. Location of stockpiles, details of stabilising materials (secondary agents and gravels type and sources), foaming agent, water source.
- iii. Process of recovering reclaimed materials and/or RAP.
- iv. Details of management of stockpiles including reclaimed materials and/or RAP.
- v. Process of blending reclaimed and/or RAP materials with virgin quarry materials if required.
- vi. Details of longitudinal and transverse joints.
- vii. The length and width of each paving run/lot.
- viii. Paving equipment (self-propelled spreading machine or grader). Where the self-propelled spreading machine is selected, details of trial using the proposed machine are submitted to the Administrator as per Clause 8.1.1.4.
- ix. Single or multiple pavement layers and details of how to prepare the surface as per Clause 8.9.9.
- x. The actions that will be undertaken in unpredicted weather change such as rain falls at the site of the works or production after production commences.
- xi. Details of procedures for working up to, or against, structures, kerb, kerb and channel and road safety barriers, and such as bridges, access chambers, gullies, culverts and concrete medians and any existing pavement cutback point, and
- xii. Sequence of operations from initial production through to final placement, compaction, trim and maintenance prior to placement of subsequent layer/lot.

h) The proposed program of works and production plan of stabilised materials.

- i) A testing program which shall include, but not be limited to, the testing methodology that shall be used to assess:
 - i. moisture content of feedstock materials and foamed bitumen stabilised materials
 - ii. the compaction standard
 - iii. layer thickness
 - iv. the stabilising agent contents, and
 - v. geometric tolerances.
- j) Where process requirements are specified in accordance with Clause 8.8, a program for the construction of the stabilisation works.

The following shall also be submitted to the Administrator with the construction procedure:

- a) Details of the proposed source of each stabilising agent; the foaming agent and the water.
- b) Compliance test results of the constituents of the proposed stabilising agents, foaming agents and water to the required specifications.
- c) Compliance test results and a representative sample of materials (if requested by the Administrator) to be stabilised excluding materials to be reclaimed from the pavement that exists within the extents of works in the contract.
- d) Compliance test results (resilient modulus) in accordance with Q139 of laboratory mixed foamed bitumen stabilised material to assess the suitability of the material to be stabilised as per Table 2 from Transport and Main Roads Technical Note 150 *Testing of Materials for Foamed Bitumen Stabilisation*, and
- e) Compliance test results (resilient modulus) in accordance with Q139 of foamed bitumen stabilised material produced in the Contractor's nominated plant. This shall be undertaken once the test results in item d) above are accepted by Administrator. The resilient modulus of the foamed bitumen stabilised materials shall conform to the requirements in Table 4 Transport and Main Roads Technical Note 150 *Testing of Materials for Foamed Bitumen Stabilisation*. This shall be undertaken by the Contractor.

The proposed construction procedure shall be submitted to the Administrator at least 21 days prior to the commencement of stabilisation works. **Milestone**

The cost of all activities associated with the above works and mix design trials including testing shall be deemed to be incorporated into the relevant work items listed in MRS09. No additional payment shall be made to the Contractor for trial mixes.

No stabilisation works shall be commenced until the construction procedure for the stabilisation works including all required compliance test results is acceptable to, and approved by, the Administrator.

Hold Point 1

No stabilisation works shall commence until the details of the sources, compliance test results and samples have been submitted to the Administrator and until, in the opinion of the Administrator, acceptable sources are identified and test results prove their suitability.

5.3 Conformance requirements

The conformance requirements that apply to lots of stabilised pavement covered in this Technical Specification are given in Clauses 6 to 10.

Material compliance testing requirements are specified in Clause 7 and construction compliance testing requirements are specified in Clause 9.

5.4 Testing frequencies and lot sizes

The material compliance testing requirements are specified in Clause 7 and construction compliance testing requirements are specified in Clause 9. Notwithstanding the aforementioned requirements, the following shall also apply:

- a) the minimum frequency of testing for the content of each stabilising agent shall not be less than that shown in Table 5.4
- b) the minimum frequency of testing of the half-life and expansion ratio of the bituminous stabilising agent shall not be less than that shown in Table 5.4
- c) the minimum frequency of checking the calibrations of mixing plant and tare of dosing conveyor and secondary agent's weight shall not be less than that shown in Table 5.4
- d) the testing frequency and lot size requirements shall be as stated in Clause 1 of Annexure MRTS09.1
- e) certification of the compliance of each stabilising agent is required for each type and source, and
- f) certification of the compliance of the potable water used is required for each type, source and sulphate content specified in Clause 6.3.

Table 5.4 – The minimum frequency for calibration and testing for stabilising agent contents and foaming properties

Test	Minimum Testing Frequency
Calibration of mixing plant	Calibration process shall be undertaken as described in Clause 5.2 (f) at the start of each shift and prior to the production of foamed bitumen stabilised material. Calibration/taring of the dosing conveyor and secondary agent weigh scales shall be checked and recorded at the start of the production daily. Additional check shall be undertaken if ordered by the Administrator.
Foamed bitumen content	Recorded at least once per 100 tonnes of continuous production with a minimum of one recording in any production run and in any lot. The Contractor shall have a current certificate of calibration for the bitumen tanker and plant. The Contractor shall produce records of actual foamed bitumen content, as and when requested by the Administrator.
Secondary stabilising agent (hydrated lime and/or fly ash blend) content	Recorded at least once per 100 tonnes of continuous production with a minimum of one recording in any production run and in any lot. The Contractor shall have a current certificate of calibration for the plant.

Test	Minimum Testing Frequency
Foamed bitumen property (half life and expansion ratio)	Tested and recorded at the start of each bitumen tanker and every 400 tonne production. Test shall be done after the addition of any bitumen to a tanker or ordered by the Administrator. Test is recommended to be done approximately 10 minutes after the start of production to allow adequate system start-up during production.

6 Material

Regular inspection, sampling and testing of pavement materials (UM1 to UM3) shall be undertaken by the Contractor during production, and construction in accordance with this Technical Specification.

The stabilised material shall be mixed using equipment that complies with Clause 8.1.1.2.

6.1 Material(s) to be stabilised

Materials to be stabilised shall comply with the following requirements:

- apart from any RAP that may be included in UM2 and UM3 materials (refer to Clause 6.1.2), they shall be comprised of unbound materials as specified in MRTS05 *Unbound Pavements*.
- they shall conform to this Technical Specification
- they shall not include any previously stabilised material, irrespective of the stabilising agent(s) used to stabilise it, unless approved by the Administrator
- they shall be free from organic and any other deleterious material
- they shall not have a water soluble sulphate content exceeding 1.9 grams of sulphate (expressed as SO₃) per litre, and
- have a PI that is not exceeding 10% or LS that is not exceeding 6%.

The material(s) used in the Contract shall be the same as the material(s) supplied as preliminary sample(s) (refer to Clause 5.2).

6.1.1 Use of materials

The type of material used shall comply with the requirements of Table 6.1.1. The average daily ESA in the design lane in the year of opening shall be as stated in Clause 9 of Annexure MRTS09.1. Where it is not so stated it shall be deemed to be greater than 1 000.

Table 6.1.1 – Material types and their permitted applications

Materials to be Stabilised	Average Daily ESA in Design Lane in Year of Opening*		
	<100	100 to <1,000	>1,000
Type UM1	Yes	Yes	Yes
Type UM2	Yes	Yes	No
Type UM3	Yes	No	No

* The average daily ESA in the design lane in the year of opening used in this table are based on a heavy vehicle growth rate not exceeding 10.0% per annum. If the heavy vehicle growth rate exceeds 10.0% per annum in any of the first five years after opening, then the average daily ESA in the design lane for the first five years after opening shall be used instead.

6.1.2 Material types

The description of UM1, UM2 and UM3 are given below in Table 6.1.2-A.

Table 6.1.2-A – Material types

Material Type	Description
UM1*	<ul style="list-style-type: none"> An unbound material that, when blended and/or mixed but not stabilised, conforms to the requirements for Type 2.1, 2.2 or 2.3 materials as specified in MRTS05 <i>Unbound Pavements</i>. 'C' or Modified 'C' particle size distribution as specified in MRTS05 <i>Unbound Pavements</i>. Comprise virgin quarried and/or approved reclaimed material.
UM2*	<ul style="list-style-type: none"> An unbound material that, when blended and/or mixed but not stabilised, conforms to the requirements for a Type 2.2 material as specified in MRTS05 <i>Unbound Pavements</i>. 'C' or Modified 'C' particle size distribution as specified in MRTS05 <i>Unbound Pavements</i>. Comprise virgin quarried, approved reclaimed material and/or RAP material but shall not include more than 10% RAP by mass.
UM3*	<ul style="list-style-type: none"> An unbound material that, when blended and/or mixed but not stabilised, conforms to the requirements for a Type 2.3 material as specified in MRTS05 <i>Unbound Pavements</i>. The particle size distribution of the Type UM3 material shall comply with Table 6.1.2-B unless otherwise approved or directed by the Administrator. Comprise virgin quarried, approved reclaimed material and/or RAP material but shall not include more than 15% RAP by mass.

* All material above shall not include any recycled products or materials other than reclaimed granular pavement material and/or RAP.

Table 6.1.2-B – Particle size distribution for type UM3 material

Sieve Size	Percentage Passing the Sieve (% By Mass)	
	Upper Limit	Lower Limit
26.5 mm	100	72
19 mm	99	62
13.2 mm	87	52
9.5 mm	77	46
6.7 mm	66	39
4.75 mm	58	32
2.36 mm	45	24
1.18 mm	36	18
600 µm	30	13
300 µm	26	9
150 µm	22	7
75 µm	20	5

6.2 Stabilising agents

All stabilising agents shall comply with the relevant Technical Specification or Australian Standard given in Table 6.2 at the time of supply and at the time of incorporation of the material to be stabilised.

Table 6.2 – Stabilising agent

Agent	Relevant Technical Specification or Australian Standard
Bitumen	Class 170 bitumen that complies with MRTS17 <i>Bitumen</i> and this Technical Specification. Refer to Clause 8.9.5 for details about the required foaming properties and to Clause 6.4 for details about the foaming agent. Where handling of bitumen occurs, the procedures to be used shall be consistent with safe handling practices which apply to bitumen-based products as defined in the <i>Austrroads Bituminous Materials Safety Guide, AP-G41/08</i> .
Hydrated Lime	Hydrated lime that complies with MRTS23 <i>Supply and Delivery of Quicklime and Hydrated Lime for Road Stabilisation</i> and this Technical Specification.
Blended hydrated lime with fly ash	Hydrated lime blended with “fine grade” fly ash complying with AS 3582.1.

The estimated contents and specified application rates are given in Clause 9 of Annexure MRTS09.1. If an estimated application rate for the foamed bitumen is not stated in Clause 9 of Annexure MRTS09.1 the content shall be 3% of the dry mass density of the material to be stabilised. If an estimated application rate for the secondary stabilising agent is not stated in Clause 9 of Annexure MRTS09.1 the content shall be 2% of the dry mass density of the material to be stabilised.

At the time of mixing, the hydrated lime shall not be more than three months old, measured from its date of manufacture and shall have an Available Lime Index of not less than 80%.

Each component of the stabilising agents shall comply with the relevant specification at the time of its introduction into the plant.

The Contractor shall make allowance for the type of hydrated lime used and the variation of the Available Lime Index of the supplied and used hydrated lime, compared to that used for the laboratory mix design (i.e. adjust the actual application rate of the hydrated lime to ensure the effective dosage achieved is no less than that achieved in the laboratory mix design). The calculation to convert the hydrated lime content used in the laboratory, to the hydrated lime content used at the plant is shown below.

Converted Hydrated Lime content (%) from laboratory Hydrated Lime content (%)

$$\text{Rate Q} = (\text{Rate H}) \times \frac{AL_x}{AL_y}$$

where:

Rate Q is the content of hydrated lime to be targeted at the plant (% by mass)

Rate H is the content of hydrated lime nominated in the design (% by mass)

AL_x is available lime index of hydrated lime (%), used in the laboratory mix design testing

AL_y is available lime index of hydrated lime (%), used in construction

6.3 Water

Water used should be potable. Where potable water is not available, the Administrator may consider water from other sources. In all cases, the water used shall contain less than 0.05% sulphates and be free from oil, acids, organic matter and any other matter that could be deleterious to the mixture.

Recycled water shall not be used to foam bitumen. Recycled water shall not be used for any other purpose without the written approval of the Administrator.

The source(s) shall not be changed without the written permission of the Administrator.

6.4 Foaming agent

Foaming agent that is approved by the Administrator shall be added in the bitumen tanker at least 30 minutes prior to incorporation of the material to be stabilised. The foaming agent content shall not be less than 0.4% and not be greater than 2% of the bitumen by mass. It shall be completely and homogeneously blended with (i.e. mixed into) the bitumen before the foamed bitumen is incorporated into the material to be stabilised.

Foaming agent shall be in a liquid form and mixed in accordance to the Supplier's recommendations.

The following information must be provided by the Contractor to the Administrator with the construction procedures (refer to Clause 5.2):

- a) the foaming agent's chemical and physical properties
- b) the recommended method(s) of handling and mixing the foaming agent
- c) the recommended dosage rate of the foaming agent to achieve the required foaming properties
- d) the recommended time for mixing the foaming agent with the bitumen to ensure the end product is uniform
- e) the effective life of the foaming agent in the bitumen at various temperatures
- f) the recommended time within which the foaming agent remains effective, measured from the date of its manufacture (e.g. its 'shelf life'), and
- g) a Materials Safety Data Sheet (MSDS) for the foaming agent.

The type and supplier shall not be changed without the written permission of the Administrator.

6.5 Reclaimed Asphalt Pavement (RAP)

Reclaimed Asphalt Pavement (RAP) material shall be obtained from the milling of asphalt pavement layers. It shall be processed such that it is well and uniformly graded, is in a free flowing and consistent state and is capable of uniform blending and incorporation through the mixing equipment. Further, processing of RAP shall involve crushing and screening operations to ensure a maximum size no greater than the maximum aggregate size as specified in Clauses 6.1.2 as relevant.

RAP material shall not contain tar binder and shall be free of contaminants such as unbound granular base material, concrete, clay, soil, organic matter or any other deleterious material. Processed RAP material shall be placed in separate stockpiles prior to use. Where RAP material has been stockpiled for some time and is no longer in a free-flowing condition, it shall be reprocessed to ensure that it is free flowing at the time of its use.

RAP may be included in Type UM2 and Type UM3 materials as specified in Clauses 6.1.2. RAP shall not be included in Type UM1 material (refer to Clause 6.1.2).

6.6 Stockpiling of materials

Stockpiles shall be located on clear, even, firm, well-drained ground and in a location where they can be clearly identified.

If a location is stated in Clause 2 of Annexure MRTS09.1, the stockpile(s) shall be so located.

There shall be a separate stockpile or stockpiles for each material of the same standard or type. For the purpose of testing, each individual feed stockpile lot shall be clearly delineated by forming a separate stockpile or stockpiles for each feed stockpile lot.

Stockpile of materials that are blended with reclaimed materials and/or RAP, shall be managed by Contractor to comply fully with the requirements of this Technical Specification and inspected by the Administrator.

The stockpiles shall be managed to maintain the moisture as per Clause 8.9.6.

All stockpiles shall be separated from other stockpiles by at least two metres and shall not be more than four metres high.

Processed RAP and/or reclaimed material shall be placed in separate stockpiles prior to use. Where RAP and/or reclaimed material has been stockpiled for some time and is no longer in a free-flowing condition, it shall be reprocessed to ensure that it is free flowing at the time of its use.

No stockpile that, in the opinion of the Administrator, is excessively wet shall be used in the stabilisation works. **Witness Point**

7 Material compliance testing

No material shall be incorporated into the works unless it has been demonstrated to the Administrator's satisfaction that all the material(s) to be used in this Contract comply fully with the requirements of this Technical Specification and the Contract. **Hold Point 2**

The Contractor is responsible for carrying out sufficient testing to ensure that the material complies with the requirements of this Technical Specification. However, the Contractor's testing program shall be such that the testing frequencies and number of tests are not less than those given in Clause 5.4 and Table 5.4.

The testing of individual samples shall be carried out in accordance with the test methods described in Clause 4.

The costs associated with material compliance testing shall be deemed to be incorporated in the relevant work items.

The material(s)/sources used in the Contract shall be the same as those for material(s) supplied as samples or for which certificates of compliance with this Technical Specification are provided.

Where feed material are to be changed during construction from the originally submitted and approved product as described in Clause 5.2, The Contractor shall provide all test results required including that of the foam bitumen stabilised materials as per Transport and Main Roads Technical Note 150 *Testing of Materials for Foamed Bitumen Stabilisation* with the proposed replacement materials for approval to

use. The associated testing for compliance and approval shall be at the expense of the Contractor with no additional costs payable by the Principal.

7.1 Stabilising agents and water

Sampling and testing shall be carried out in accordance with the relevant Technical Specifications.

A certificate of test results demonstrating compliance of each of the bituminous and secondary stabilising agents to the relevant standards shall be provided for each load, or part thereof, of each stabilising agent.

A certificate of test results demonstrating the compliance of each proposed water source shall be provided.

7.2 UM1, UM2 or UM3 material(s)

Compliance testing of UM1, UM2 or UM3 material shall be carried out in accordance with the requirements of Clause 3 of Annexure MRTS09.1.

In all cases the material to be stabilised shall also comply with Clause 6.1. Notwithstanding this, the requirements of this Technical Specification take precedence.

Compliance testing of materials shall be undertaken for each lot. A lot shall include only material of the same type. Samples for compliance testing shall be selected by random sampling.

7.3 Stabilised materials

Foam bitumen stabilised material with the secondary agent shall be tested as per Transport and Main Roads Technical Note 150 *Testing of Materials for Foamed Bitumen Stabilisation* prior to commencing the works. This shall be undertaken with the proposed materials to demonstrate the capability to attain the specified modulus.

The test results from Clauses 7.3.1 and 7.3.2 shall be included in the Construction procedure (refer to Clause 5.2).

The cost of all activities associated with laboratory and production mix design trials including testing shall be deemed to be incorporated into the relevant work items listed in MRS09. No additional payment will be made to the Contractor for trial mixes.

7.3.1 Laboratory trial

Mix design trials using each representative sample of the proposed pavement material and varying quantities of the secondary stabilising agents shall be undertaken in the laboratory to evaluate the optimum lime and bitumen contents. The laboratory testing is required to produce a foamed bitumen stabilised mix that meets the modulus mix design limits as set out in Table 2 of Transport and Main Roads Technical Note 150 *Testing of Materials for Foamed Bitumen Stabilisation*.

7.3.2 Plant production trial

The nominated mix design proportion chosen from Clause 7.3.1 shall be used to run a production trial mix through the Contractor's mixing plant. The foamed bitumen stabilised mix produced from the Contractor's mixing plant shall comply with the mix design limits as set out in Table 4 of Transport and Main Roads Technical Note 150 *Testing of Materials for Foamed Bitumen Stabilisation*.

The mixing plant used for the production plant shall be the same plant proposed to be used by the contractor for production during construction.

8 Construction

Prior to acceptance (Clause 9.8), manufacturing stabilised materials and construction of a stabilised layer shall not proceed until the Administrator is satisfied that the requirements covered by Clause 8.1 to Clause 8.10.6.3.2 and Clause 9.1 to Clause 9.5 are met. **Hold Point 3**

The material(s)/sources used in the Contract shall be the same as those for material(s) supplied as samples or for which certificates of compliance with this Technical Specification are provided.

The thickness of the stabilised layer/layers is/are stated in Clause 9 of Annexure MRTS09.1.

8.1 Equipment

Equipment capable of efficiently carrying out the following functions shall be continuously available, and in use as required, to the Site:

- a) transporting, transferring and storing mix constituents
- b) manufacturing and mixing
- c) delivering the mixture to job site
- d) paving
- e) compacting and trimming
- f) preparing edges and surfaces
- g) water curing, and
- h) application of the bituminous curing coat, where specified, to the final layer.

8.1.1 Equipment requirements

The equipment specified below shall comply with the minimum specifications listed in the Clause 8.1.1.1 to Clause 8.1.1.8.

Regular calibration of all equipment shall be undertaken in accordance with the manufacturer's guidelines. All calibrations shall be recorded and, where requested by the Administrator, shall be provided to the Administrator as soon as possible, but no later than seven calendar days after the receipt of any such request.

8.1.1.1 Equipment used to transport, transfer and store mix constituents

The stabilising agents and foaming agent shall be transported and stored using vessels that are both waterproof and watertight. Apparatus used to transfer the stabilising agents and foaming agent between transport and storage vessels shall also be waterproof during the transfer process. These vessels and apparatus shall be emptied and cleaned each time a different material is introduced into them prior to the introduction the different material.

8.1.1.2 Manufacturing and mixing equipment

Mixing equipment shall meet at least the following requirements:

- a) It shall be a stationary, driven pugmill that is purpose built for the process of mixing road-making materials, and shall be maintained and calibrated so as to be able to produce stabilised material that complies with this Technical Specification.
- b) It shall have storage facilities for water and the foaming agent as required.

- c) It shall have load cells (or an external calibrated secondary weighing system) for the silo containing the secondary stabilising agent.
- d) It shall be capable of producing plant mixed stabilised pavement material that is uniform and not segregated and complies with this Technical Specification.
- e) It shall be capable of uniformly incorporating all constituent materials into the materials(s) to be stabilised.
- f) It shall have displays that allow continuous monitoring of each mix constituent.
- g) It shall have a minimum rated continuous production rate that is greater of 140 tonnes per hour of complying mix per hour and the Contractor's placing rate. For projects which require limited quantities, production rate less than 100 tonnes per hour of mix complying with this Technical Specification can be allowed subject to the approval from the Administrator.
- h) It shall have a fully computerised and calibrated control system with read-out meters at the plant's control station to allow continuous monitoring of each of the mix constituents. This shall include a variable feed rate with calibrated load-cells for the secondary stabilising agent.
- i) A water pump with flow control to adjust the amount of water. Water distribution system inside the mixing chamber shall be located immediately after foam bitumen incorporation is completed.
- j) It shall have controlled metering systems for the addition of all constituents.
- k) It shall have the necessary conveyors, source of power and controls.
- l) It shall be fitted with a readily accessible inspection or test jet that can be used to confirm the required flow of bitumen and that the required expansion and half life properties of the foamed bitumen are being achieved.
- m) All bitumen/foaming jets fitted must be self-cleansing.
- n) Where water is to be drawn from an approved source, an efficient filter is to be provided on the suction pipe to ensure that the water is free from anything that could cause blockage of jets, piping, etc. in the equipment.

In addition, the mixing equipment shall be regularly maintained and calibrated, including all meters within the plant, in accordance with the manufacturer's/supplier's recommendations and to ensure the requirements of this Technical Specification are met. The results of equipment calibration checks shall be recorded and reported to the Administrator as specified in Clause 8.1.1.

8.1.1.3 Delivery equipment

Vehicles used for the delivery of the mix shall be of the open-body truck type, equipped with adequate covers and capable of transporting and discharging the mixture without segregation. If discharging into the hopper of a paving machine, the vehicles shall be designed or equipped with the capacity to efficiently discharge into the hopper consistently and without spillage.

Delivery equipment shall be clean and free from any contaminant. It shall be sufficient to ensure that the mix can be continuously delivered at a rate that is at least equal to the Contractor's placing rate.

8.1.1.4 Paving equipment

The mixture shall be placed by the equipment nominated in Clause 4 of Annexure MRTS09.1. Where no indication is given in Clause 4 of Annexure MRTS09.1 a grader for this work shall be used.

Self-propelled spreading machine shall have the capacity to either:

- a) place and spread the mixture on the prepared surface to the required uncompacted layer thickness, width and shape in one pass, or
- b) spread previously placed windrows of the mixture to the required uncompacted layer thickness, width and shape in one pass.

Self-propelled spreading machine shall also have the capacity to compact the stabilised layer to between 85% and 95% of the required level of compaction.

A trial section shall be constructed using the self-propelled spreading machine proposed by the Contractor. **Hold Point 4**. A trial section shall be at least 100 metres long with longitudinal joints. Trial section shall be offsite unless approved by the Administrator.

If a grader is used to place the stabilised material it shall be manned by a final trim operator.

Notwithstanding the above, the Administrator may approve other methods of paving in areas where the pavement width is such that the use of a self-propelled spreading machine is impracticable. Irrespective of what equipment is used, the mix shall be placed and spread such that there is no segregation of it.

8.1.1.5 Equipment for preparation for the layer edges and surfaces

The equipment for the preparation of the layer edges shall be capable of cleanly and neatly cutting the edges vertically and removing all the cut material from the formation.

The equipment for the preparation of the surface of each layer shall include equipment capable of sweeping the layer and/or evenly distributing the tack coat at the required rate on the layer's surface and edges.

8.1.1.6 Equipment for water curing

The equipment used for water curing shall have the capacity to store at least 6 000 litres of water and be capable of discharging the water in a fine and even mist over the pavement surface in a manner that avoids slurring of the surface, pavement instability and erosion, and leaching of the stabilising agent.

8.1.1.7 Other equipment

Equipment used to produce the foamed bitumen stabilised material shall include aggregate screens for reclaimed materials and RAP that shall be used to control the particle size distribution of the material introduced into the mixing equipment.

Front end loader bucket shall be clean and free of debris at all times.

8.2 Program of works

The Contractor shall submit the proposed program of the stabilisation works to the Administrator at least 21 days prior to the commencement of works, unless otherwise agreed with the Administrator.

Works shall not commence until the program has been approved by the Administrator (refer to Clause 5.2 and Hold Point 1).

8.3 Site, services, utilities buildings and drainage

A survey of the site to determine the location and depth of services, utilities, buildings and drainage components shall be carried out prior to commencement of construction. The survey shall include details of how these, equipment and personnel on site shall be protected and how the construction works shall be completed without any detrimental effects to them. The survey shall be included in the proposed construction procedure (refer to Clause 5.2).

Works shall not commence until the survey has been completed and a copy of the report provided to the Administrator. **Hold Point 5**

8.4 Allowable time for placement, compaction and trimming

The time within which placement, compaction and trimming of the stabilised layer shall be completed is the difference between the allowable working time (refer to Clause 8.6) and the allowable stockpile time (refer to Clause 8.5). It shall be as stated in Clause 10 of Annexure MRTS09.1. Where it is not so stated, it shall be three hours.

Notwithstanding the above, it shall not exceed three hours.

8.5 Allowable stockpile time

The maximum time that the stabilised material shall be stockpiled, measured from the commencement of incorporating/mixing of the foamed bitumen into the material to be stabilised to when it is first removed from its original stockpile to the job site, shall be as stated in Clause 11 of Annexure MRTS09.1. Where it is not so stated it shall be five hours.

In instance where stabilised materials cannot be removed from the stockpile within the allowable stockpile time due to unforeseeable circumstances, the Administrator may consider extending the allowable stockpile time. In this circumstance, the Contractor shall be responsible to complete works including delivery, placement, compaction and trimming within the allowable working time specified in Clause 8.6.

8.6 Allowable working time

The allowable working time, measured from the commencement of incorporating/mixing of the foamed bitumen into the material to be stabilised to the completion of compaction and trimming of the stabilised materials, shall be as stated in Clause 12 of Annexure MRTS09.1. Where it is not so stated it shall be eight hours.

Notwithstanding the above, it shall not exceed eight hours.

Rework to meet this Technical Specification shall be performed in full depth of individual layer within 24 hours.

8.7 Construction process

8.7.1 General

The construction process shall be based either on a process requirement that complies with Clause 8.7.2 or a product standard that complies with Clause 8.7.3. The method for this Contract shall be as stated in Clause 9 of Annexure MRTS09.1.

8.7.2 Construction based on process requirements

Construction based on a process requirement shall:

- a) incorporate the methodology and construction of trial sections in accordance with the requirements of Clause 8.8
- b) comply with the construction requirements stated in Clause 8.9, and
- c) comply with the product standards stated in Clause 8.10 except that, for sections represented by a trial section in which the required compaction is achieved, compaction testing shall not be required on completed works other than trial sections.

8.7.3 Construction based on product standards

Construction based on a product standard shall:

- a) comply with the construction requirements stated in Clause 8.9, and
- b) comply with the product standards stated in Clause 8.10.

8.8 Process requirements

8.8.1 Methodology

Each section of the works with a specific combination of stabilising agent type(s), stabilising agent content(s), material(s) to be stabilised, pavement thickness and pavement/subgrade support shall be identified as a separate area for construction.

A trial section shall be constructed for each separate area for construction in accordance with the requirements of Clause 8.8.2.

The compaction of each trial section shall be checked for compaction in accordance with Clause 8.10.3 and tested in accordance with Clause 5.4. If the characteristic value of the relative compactions for the trial section is not less than the value specified in Clause 8.10.3, no further compaction testing shall be carried out for the balance of the area for construction that is represented by that trial section, provided that the same construction plant, processes and methodology are used to construct the remaining area as that used for the construction of the trial section.

If the characteristic value of the relative compactions for the trial section is less than the value specified in Clause 8.10.3, the trial section shall be rectified so that it complies with this Technical Specification and an additional trial section shall be constructed and assessed in accordance with this Clause 8.8.

Construction based on a process requirement and a trial shall not be used for the balance of any works without approval of the Administrator. **Hold Point 6**

8.8.2 Trial section

A trial section shall be constructed using the same construction plant, processes and methodology that it is proposed to use for the remainder of the works represented by the trial section.

Witness Point

A trial section shall be at least 100 metres long and include longitudinal joints described in Clause 8.9.15.2.

All operations, testing, etc. required by this Technical Specification, including compaction testing, shall be used in the construction and testing of each trial section.

8.9 Construction requirements

8.9.1 Reclaiming and processing existing pavement materials

The parts of existing pavement(s) to be reclaimed via milling or approved any other method shall be those described in Clause 13 of Annexure MRTS09.1. Where no details are given in Clause 13 of Annexure MRTS09.1 no materials shall be reclaimed.

The Contractor shall process all materials to be reclaimed (e.g. refer to Clause 8.9.4) with the aim of reusing them to produce a material that is suitable for stabilisation (refer to Clause 6.1). This may include blending the reclaimed pavement materials with other materials (e.g. imported materials). The proportion and amount of reclaimed materials reused shall be maximised and approved by Administrator.

8.9.2 Milling

The parts of existing pavement(s) to be:

- a) Milled with the Contractor being responsible for removal and disposal of all milled materials shall be those described in Clause 14 of Annexure MRTS09.1.
- b) Milled with the Principal taking possession of all milled materials shall be those described in Clauses 15.1 and 15.2 of Annexure MRTS09.1.

Where no details are given in Clauses 14 or 15 of Annexure MRTS09.1 no milling shall occur.

In addition:

- a) Where the Contractor takes possession of milled materials the work shall comply with Clauses 8.9.2 and 8.9.2.1, and
- b) Where the Principal takes possession of milled materials the work shall comply with Clauses 8.9.2 and 8.9.2.2.

Milling shall be undertaken to comply with the requirements of Clause 8.10.4.2.1. Any material removed in excess of the tolerances given in Clause 8.10.4.2.1 shall be replaced as follows:

- a) Where the exposed material at the bottom of the area milled is all unbound granular material, then foamed bitumen stabilised material that complies with this Technical Specification shall be used to replace the material milled off below the specified depth plus 10 mm.
- b) In all other cases the material milled off below the specified depth plus 10 mm shall be replaced with a like material that is approved by the Administrator.

Milling shall be undertaken such that damage to the remaining pavement, relieving slabs, bridge abutments, kerb, kerb and channel or other structures is avoided. Further, milling in these circumstances shall be undertaken in a manner that is approved by the Administrator. The Contractor shall restore at no cost to the Principal any area or items damaged during the milling operations.

8.9.2.1 Removal and disposal of milled materials

Where specified in Clause 14 of Annexure MRTS09.1, the Contractor shall mill the existing pavement to the dimensions specified in the Drawings or Contract. The Contractor shall be responsible for the removal and disposal of all such milled materials. Further, this removal and disposal shall comply with MRTS01 *Introduction to Technical Specifications*.

8.9.2.2 Milled materials to be returned to the Principal

Where specified in Clause 15.1 of Annexure MRTS09.1, the Contractor shall mill the existing pavement to the dimensions specified in the Drawings or Contract. The Contractor shall then remove the milled materials, load them into transport vehicles, transport the materials to the stockpile site(s) specified in Clause 15.2 of Annexure MRTS09.1 or approved by Administrator and unload/stockpile the materials at the nominated site(s). Stockpiling shall comply with the requirements of Clause 6.6.

8.9.3 Processing of reclaimed and/or RAP materials before mixing and stabilising

Screens shall be used to control the particle size distribution of the reclaim material introduced into the mixing equipment. The material(s) to be stabilised shall be passed through screens to disaggregate it/them into different sizes. Oversize particles shall not be used in the stabilised material.

Milled RAP material included in the Type UM2 or UM3 shall be processed to a well graded, free flowing and consistent state. RAP material shall be screened to ensure a maximum size no greater than the maximum aggregate size of Type UM2 or UM3 material being produced.

Screened reclaimed and/or RAP materials shall be controlled to ensure uniformity and homogeneity of materials to be achieved when they are blended with imported quarry materials.

The Contractor shall be responsible for the removal and disposal of all unsuitable materials, and the cost of this shall be deemed to be included in the rate of the relevant schedule item or contract price (i.e. no additional payment shall be made by the Principal). Materials containing the disaggregated materials shall be complied as specified in Clause 6.1 prior to incorporating with the stabilising agents.

8.9.4 Transportation, storage and handling of stabilising agents

Bitumen and bitumen mixed with foaming agent shall be transported, stored, handled and transferred using the recommended equipment and procedures described in *Austrroads Bituminous Materials Safety Guide* (Austrroads Publication No. AP-G41/08). Notwithstanding this requirement, bitumen and bitumen mixed with foaming agent shall be transported, stored, handled and transferred as specified in MRTS17 *Bitumen*.

The hydrated lime shall be transported and stored using equipment that is both waterproof and watertight. Equipment used to transfer the secondary stabilising agent shall also be waterproof during the transfer process.

8.9.5 Foamed bitumen properties

The foamed bitumen shall exhibit an expansion ratio that is greater than 10 and a half life that is greater than 20 seconds. This shall be achieved following incorporation of any foaming agent and described in Clause 5.4. The bitumen shall be incorporated to material to be stabilised from the bitumen storage container at a temperature between 180°C and 190°C. Bitumen temperature shall not fall below 170°C throughout the bitumen incorporation process. The foaming properties of the bituminous stabilising agent within the mixing equipment shall be determined using the external test/inspection jet/nozzle. The bituminous stabilising agent shall not be incorporated into the material to be stabilised where the foaming properties of it do not comply with the requirements of this Technical Specification. **Hold Point 7**

8.9.6 Relative Moisture Ratio of Feed Stockpiles (RMR FSP)

The moisture ratio of feed stockpile shall be determined prior to incorporation of the stabilising agent and recorded in accordance with Test Method Q250. The minimum testing frequency shall be as per

Clause 1.2 of Annexure MRTS09.1. The Contractor shall ensure that the relative moisture ratio of the feed stockpile is not less than 40% nor greater than 55%.

The Relative Moisture Ratio (Q250) values shall be calculated using the individual moisture content (Q102A, Q102B or Q102D) compared to the optimum moisture content (from Q142A) for each feed stockpile.

The required relative moisture ratio for the blended material feed stockpile (RMR FSP) and the foamed bitumen stabilised material (RMR FB) is shown in Figure 8.9.6. The materials and stockpile management shall meet the requirement in accordance with Clauses 6.1, 6.6 and 8.9.7.

Figure 8.9.6 – Required moisture content on feed stockpile and stabilised material

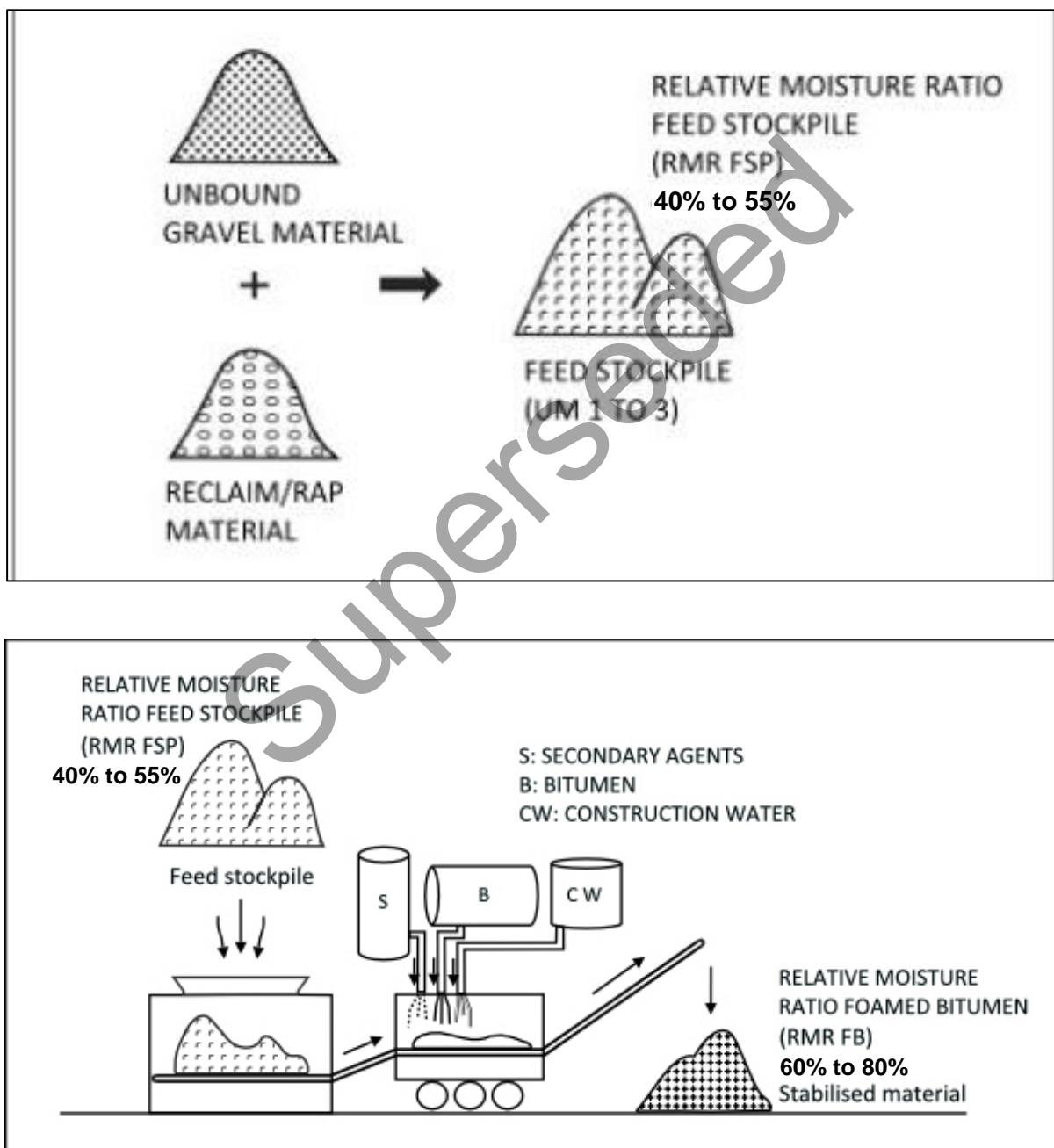

8.9.7 Stockpiling of stabilised materials

Stabilised material may be stockpiled such that material can be continuously, consistently delivered at a rate that is at least equal to the Contractor's placing rate provided that all allowable times given in Clauses 8.4, 8.5 and 8.6 are not exceeded. Any stabilised material in stockpiles older than eight hours, measured from the incorporation of the foamed bitumen into the material to be stabilised, or where allowable times given in Clauses 8.4, 8.5 and 8.6 for stockpiled materials are exceeded shall not be used unless approved by the Administrator.

Stabilised materials shall be protected with cover or light plastic material to prevent the ingress of moisture and other contaminant.

Stockpiles of stabilised material shall comply with the requirements of Clause 6.6.

8.9.8 Segregation

Segregation is the uneven distribution of particle sizes. The entire construction process, including mixing, stockpiling, transporting and paving, shall minimise segregation so that the particle size distribution of the material in the pavement complies with the particle size distribution requirements specified, with due allowance being made for the inclusion of the stabilising agents.

Further, the material laid ready for compaction shall not have any visible areas of segregation. Any segregated areas should be removed and disposed of in accordance with Clause 10 of MRTS01 *Introduction to Technical Specifications* and replaced with fresh mix before compaction commences. No separate or additional payment shall be made for the removal and disposal of segregated material or the supply of the fresh mix. The cost of all activities associated with the removal and disposal of segregated material and material to replace the segregated material shall be deemed to be incorporated into the relevant works.

The Administrator may arrange for testing of the particle size distributions or stabilised layer to evaluate areas of suspected segregation.

8.9.9 Preparation of surfaces

Where a stabilised layer is to be placed on the surface of a bound layer or on concrete the Contractor shall carry out the works detailed in this Clause and Clauses 8.9.9.1. **Witness Point**

Where a stabilised layer is to be placed on any other surface the Contractor shall carry out the works detailed in this clause and Clauses 8.9.9.2 and 8.9.9.3. **Witness Point**

For all surfaces preparation shall include the removal of all foreign and loose material with a road broom.

Unsound materials shall be removed and disposed of as agreed with the Administrator. Where there is a dispute about what constitutes unsound materials and/or their extent they shall be as determined by the Administrator. The unsound materials shall be replaced with a like material as approved by the Administrator. For instance unless otherwise directed by the Administrator:

- a) Unsound foamed bitumen stabilised material shall be replaced with an appropriate, corresponding foamed bitumen stabilised material that complies with this Technical Specification.
- b) Unsound asphalt shall be replaced with an appropriate, corresponding mix type that complies with MRTS30 *Asphalt Pavements*, or foamed bitumen stabilised material that complies with this Technical Specification.

- c) Unsound cementitiously stabilised or modified material shall be replaced with an appropriate, corresponding mix type that complies with MRTS08 *Plant-Mixed Stabilised Pavements using Cement or Cementitious Blends*, or foamed bitumen stabilised material that complies with this Technical Specification, and
- d) Unsound unbound granular material shall be replaced with a corresponding type that complies with MRTS05 *Unbound Pavements*.

All unsuitable, unsound, foreign and/or loose material generated from the preparatory works shall be removed from the road formation and utilised/disposed of in accordance with the requirements of MRTS01 *Introduction to Technical Specifications*.

8.9.9.1 Preparation of bound and concrete surfaces and bound pavements

The surface of the pavement or substrate shall be dry and thoroughly mechanically swept using a rotary broom to remove any foreign, loose material or other deleterious material that may be present. Any deleterious material that still adheres to the surface after sweeping shall be removed by other means without damaging the pavement or substrate. Any damage caused by the removal of such materials shall be rectified to the satisfaction of the Administrator at the Contractor's expense.

In addition to and following mechanical sweeping:

- a) Areas of oil or fuel spillage shall be cleaned with detergent, flushed with clean water and allowed to dry prior to application of the tack coat, and
- b) Cracks, joints or holes in the pavement/bridge deck shall be rectified as stated in Clauses 8.9.9.1.1 and 8.9.9.1.2.

Frames for manhole covers, gully gratings, kerbs and other structures shall have the joint surfaces cleaned so that they are free of any extraneous material.

8.9.9.1.1 Crack filling

In the areas shown in the Drawings or stated in Clause 16 of Annexure MRTS09.1, cracks wider than 2 mm shall be filled prior to placement of any stabilised material/layer.

The Contractor shall mark out, in the presence of the Administrator, the extent of crack filling to be carried out. **Hold Point 8**

The cracks to be filled shall be cleaned before they are filled.

Cracks shall be filled level with the surrounding surface with a polymer modified sealant approved by the Administrator.

8.9.9.1.2 Strain alleviating geotextile strips

In the areas shown on the Drawings or stated in Clause 17 of Annexure MRTS09.1, strain alleviating geotextile strips shall be applied to existing cracks prior to placement of any stabilised material/layer. The contractor shall mark out, in the presence of the Administrator, the extent of the strain alleviating geotextile strips to be applied. **Hold Point 9**

Strain alleviating geotextile strips shall be non-woven polyester geotextile pre-coated with a rubberised bitumen adhesive base.

Prior to application of the geotextile strips, the existing surface shall be swept clean and shall be free of dust, grit, surface moisture and vegetation. Further, any cracks or joints wider than 2 mm shall be filled in accordance with the requirements of Clause 8.9.9.1.1.

The surface to which any strain alleviating geotextile strip is to be applied shall be sprayed with a bituminous emulsion tack coat at a rate of 0.25 litres/m², unless otherwise directed by the Administrator. Alternatively, a proprietary primer that is recommended by the manufacturer of the strain alleviating geotextile strips may be used.

The strain alleviating geotextile strips shall be laid to cover a minimum width of 250 mm (nominally 125 mm on each side of the crack). Placement of the strain alleviating geotextile strips shall be carried where:

- a) pavement temperature is not less than 15°C and rain is not likely to fall prior to the completion of the installation, and
- b) pavement surface is clean and absolutely dry.

Joints in the strain alleviating geotextile strips shall be overlapped in accordance with the manufacturer's recommendations.

After placement, the strain alleviating geotextile strips shall be rolled with at least one pass of a pneumatic-tyred roller to ensure proper adhesion. The strain alleviating geotextile strips shall be placed free of wrinkles or creases.

Traffic shall not be permitted to traverse the strain alleviating geotextile strips for at least 20 minutes after rolling.

8.9.9.2 Preparation of granular surface or sealed granular pavement

Wherever a stabilised layer is to be laid over pavement with a bituminous surfacing, the bituminous surfacing shall be lightly scarified or pre-milled.

The Contractor shall ensure the surface onto which a stabilised layer is to be constructed is well compacted, trimmed and prepared before material for the overlying stabilised layer is placed. Proof rolling shall be carried out in accordance with Clause 9.7. Where movement is observed under proof rolling, construction of the stabilised layer shall not proceed until works are undertaken to eliminate movement under proof rolling.

The prepared surface shall be swept with a road broom until the larger particles in the surface of the pavement are slightly exposed but ensuring excessive erosion of the surrounding finer material does not occur.

8.9.9.3 Preparation of a stabilised layer surface prior to the placement of the next stabilised layer

Where a stabilised layer is to be overlaid directly with another stabilised layer, the finished surface shall be cut-back:

- after the completion of compaction, and
- within the same work shift as the material was placed.

Cutting back the surface shall uniformly remove a lens of material across the full width of the stabilised pavement layer to produce a roughly textured surface. Scratching or marking the surface is not

sufficient. A rough surface texture shall be maintained until such time that the next stabilised pavement layer is placed on top. Cutback performed by a grader is illustrated in Figure 8.9.9.3.

All cut-back material shall be disposed of in accordance with Clause 10 of MRTS01 *Introduction to Technical Specifications*. No separate or additional payment shall be made to the Principal for the removal and disposal of material cut to waste.

The Contractor shall ensure that the stabilised pavement shall be cured as per the requirements of Clause 8.9.18.

Figure 8.9.9.3 – Cutback on smooth surface with a grader

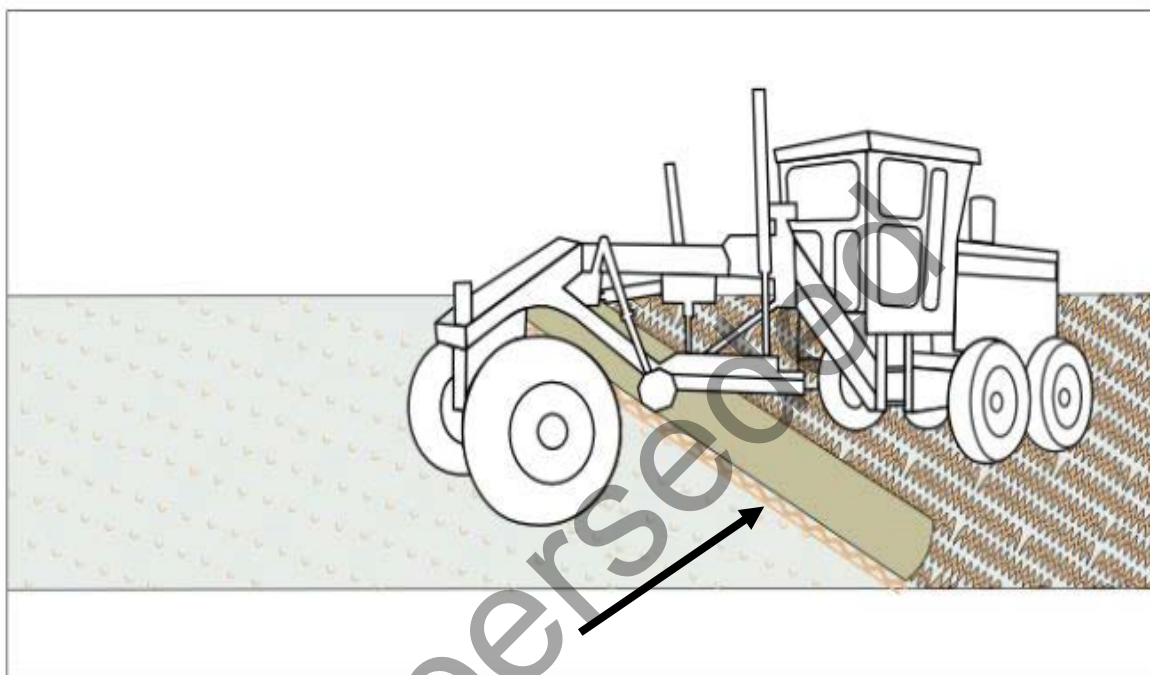

Cut-back on smooth surface prior to placing the next stabilised foamed bitumen materials to create a rough texture to improve bonding to a subsequent stabilised layer. The cut-back by a grader shall be undertaken after compaction and within the same work shift. This can be performed outside the allowable working time.

8.9.10 Layer thickness

The compacted thickness specified for each layer of stabilised material shall be at least 125 mm and no greater than 250 mm for all foamed bitumen pavement layers, unless otherwise approved by the Administrator. The required roller for individual layer thickness is described in Table 8.9.10. The Contractor shall achieve the required characteristic value of the relative compactions in accordance with Clause 8.10.3.

Table 8.9.10 Minimum roller requirements at pavement layer thickness

Minimum Roller Requirements	Compacted Layer Thickness Range	
	Maximum (mm)	Minimum (mm)
Smooth drum and multi tyre	200	125
Pad foot, smooth drum and multi tyre	250	200

Individual layer thickness in excess of the above maximum limits shall be constructed in multiple layers.

8.9.11 Placement

The stabilised material shall be produced, transferred and spread in one concurrent operation. When it is placed using a mechanised paver, each individual layer shall be placed in one pass that meets the requirements of this Technical Specification without the addition of extra material(s) except as detailed in Clause 8.9.8.

When the stabilised material is placed using a grader, it shall be manned by a final trim operator.

After placement, the layer shall be compacted and trimmed in accordance with this Technical Specification to produce a tight dense surface that has properties that are within the required tolerances.

8.9.12 Compaction

Compaction shall be completed within the allowable working time (refer to Clause 8.6). This shall be carried out using an appropriate roller(s) that is capable of achieving relatively uniform compaction over the depth of each stabilised layer. The stabilised layer shall be compacted as specified in Clause 8.10.3.

The stabilised layer of greater than 200 mm thick shall be compacted with a pad foot roller. The Contractor shall take care to ensure that the pattern of any pad foot roller is not left on the finished surface of the stabilised layer. The Contractor shall use a smooth drum roller and multi-tyre roller to complete the finished surface of the stabilised material.

The Contractor shall ensure the longitudinal joints including at the road crown are achieved uniform compaction over the depth of the stabilised layer.

8.9.13 Trimming after compaction

Trimming of the pavement, if required, shall be carried out as soon as practicable after compaction of the pavement has been completed within the allowable working time as specified in Clause 8.6.

After initial trimming subsequent trimming may be undertaken on one or more occasions in preparation for application of the final wearing course, and with the objective of meeting shape and level requirements, and shall involve cutting to waste.

The trimmed surface shall be free from loose pockets, holes, bumps and lenses of material such that it satisfies the Administrator. Notwithstanding this no marks caused by a pad foot or other equipment shall remain on the surface after final trimming.

Localised depressions and rises shall be treated as determined jointly by the Administrator and the Contractor.

Where the multiple stabilised layers are constructed, a hard cut shall be done by a grader on the compacted layer as per Clause 8.9.9.3.

All trimming operations, including a hard cut (refer to Clause 8.9.9.3), shall be cut to waste. All material cut to waste shall be removed and disposed of in accordance with Clause 10 of MRTS01 *Introduction to Technical Specifications*. No separate or additional payment shall be made for the removal and disposal of material cut to waste. The cost of all activities associated with the removal and disposal of material cut to waste shall be deemed to be incorporated into the relevant works.

8.9.14 Period for placement, compaction and trimming

Placement, compaction and trimming shall be completed within working times specified in Clauses 8.4, 8.5 and 8.6.

8.9.15 Construction joints

8.9.15.1 General

Joints shall be constructed such that the material at the joints complies with the requirements of this Technical Specification.

A construction joint shall be deemed fresh when the material on each side of the joint has been stabilised, placed and compacted within the allowable working time (refer to Clause 8.6).

8.9.15.2 Longitudinal joints

Longitudinal joints shall not be located in the through traffic wheel paths.

Where a fresh longitudinal joint between adjacent runs is to be compacted, the outside 300 mm of material from the first run shall be left uncompacted until the adjacent material is ready for compaction. The joint shall be water cured during this period. When the fresh joint is compacted, the roller shall be partially supported on the portion of the first run that has been previously compacted.

Joints that are not fresh shall be cut back for the full depth of the layer to form a neat clean vertical face. The minimum distance for cutting back into previously compacted material shall be greater of 75 mm and the distance to a point where the stabilised material compliance with this Technical Specification.

Where there is more than one layer of stabilised material the longitudinal joints of each layer shall be offset from the underlying layer's longitudinal joint by a minimum distance of 150 mm.

No separate or additional payment shall be made for the disposal of material cut to waste. The cost of all activities associated with the disposal of material cut to waste shall be deemed to be incorporated into the relevant works items.

8.9.15.3 Transverse joints

For transverse joints that are not made during the allowable working time, the adjoining section previously stabilised shall be cut back to form a neat clean vertical face for the full depth of the stabilised layer, by the greater of 150 mm and the distance to a point where the stabilised material complies with this Technical Specification.

Where there is more than one layer of stabilised material the joint of each layer shall be offset from the underlying layer's joint by a minimum distance of 150 mm.

No separate or additional payment shall be made for the disposal of material cut to waste. The cost of all activities associated with the disposal of material cut to waste shall be deemed to be incorporated into the relevant works items.

8.9.16 Joining new work to existing pavements and structures

Existing pavements shall be cut back as shown or described in the Drawings or Contract to provide:

- a) a clean, vertical surface at the joint line against which the stabilised layer/material is to be placed, and
- b) a longitudinal taper such that the minimum layer thickness is as stated in Clause 8.9.10.

The stabilised material shall be compacted so that the completed layer is neatly finished to match adjacent pavements and structures.

8.9.17 Requirement of trafficking on stabilised layer

The Contractor shall provide for and manage traffic in accordance with MRTS02 *Provision for Traffic* and this Technical Specification. Notwithstanding this, the requirements of this Technical Specification shall take precedence over the requirements of MRTS02 *Provision for Traffic*.

Where the average daily ESA is the design lane in the year of opening is 100 or more, apart from necessary construction traffic, no stabilised layer shall be trafficked until a bituminous surfacing has been constructed on it.

Stabilised layers may be opened to traffic with approval of the Administrator after inspecting visual deflection where the average daily ESA is the design lane in the year of opening is less than 100.

The Contractor shall take all necessary precautions to protect the work from damage until the work has been surfaced with the final wearing course.

8.9.18 Curing

Water curing shall commence immediately after the completion of compaction. Layers other than the topmost stabilised layer(s) shall be water cured until covered by successive layer. The topmost stabilised layer shall be water cured until a bituminous surfacing a cover aggregate as described in Clause 8.9.19 has been applied.

The surfaces and edges of stabilised layers to be water cured shall be maintained in a continuously damp condition, using the occasional application of a uniformly applied fine mist. Water shall be applied in a manner such that slurring of the surface(s) and edge(s), pavement instability, pavement erosion flushing and/or leaching of the stabilising agents are all avoided.

8.9.19 Bituminous surfacing

Unless otherwise approved by the Administrator, a bituminous surfacing with a cover aggregate shall be applied within seven calendar days of the completion of the topmost stabilised layer.

8.9.20 Maintenance of the stabilised layer

The stabilised layer shall be maintained by the Contractor until a bituminous surfacing with a cover aggregate is applied, until the stabilised layer is covered by another pavement layer or until the end of the defects liability period, whichever is the longer.

No separate or additional payment shall be made for maintenance of the stabilised layer prior to the application of a bituminous surfacing with a cover aggregate. The cost of all activities associated with

maintenance of the stabilised layer prior to the application of a bituminous surfacing shall be deemed to be incorporated into the relevant work items for the stabilised layer.

8.9.21 Conditions under which stabilisation and placement shall not proceed

The entire stabilisation and placement process shall not proceed:

- a) during rainfall
- b) when rainfall appears to be imminent
- c) during conditions that may result in the work causing nuisance or danger to people, property, or the environment
- d) when the temperature of any feed stockpile, measured 50 mm below the surface of the stockpile, drops below 10°C unless approved by the Administrator to proceed
- e) when the air temperature, measured in the shade, exceeds 40°C
- f) when Relative Moisture Ratio of Feed Stockpile (RMR FSP) is not within the values specified in Clause 8.9.6, unless approved by the Administrator to proceed, or
- g) when Relative Moisture Ratio of Foamed Bitumen (RMR FB) is not within the values specified in Clause 8.9.6, unless approved by the Administrator to proceed.

8.10 Product standards

Compliance testing of the pavement shall be undertaken for each lot. Where a process standard is specified the compaction requirements in this clause apply to trial section(s) but not to other sections. Where a product standard is specified the compaction requirements in this clause apply to all sections/lots.

8.10.1 Stabilising agent contents

8.10.1.1 Ordered contents

At least 21 days prior to the commencement of stabilisation works, the Administrator shall confirm or adjust the estimated bitumen and secondary stabilising agent contents stated in Clause 9 of Annexure MRTS09.1.

The confirmed or adjusted stabilising agent contents shall be defined as the ordered bitumen and secondary stabilising agent contents. **Milestone**

8.10.1.2 Actual stabilising agent contents

The actual bituminous and hydrated lime contents shall be represented by the characteristic value of the stabilising agent content (refer to Clause 9.4 and Clause 9.5 respectively). It shall be within plus or minus 10% of the ordered content as specified in Clause 8.10.1.1.

The Principal shall only pay for:

- a) The quantity of stabilising agents used. The bituminous content measured in litre in hot temperature condition shall be calculated to volume at 15°C, and
- b) The quantity of stabilising agents required to meet the tolerances given in this clause.

The Contractor shall be liable for materials used that are in excess of the ordered stabilising agent content plus 10%.

8.10.2 Relative Moisture Ratio Foamed Bitumen (RMR FB)

Unless otherwise approved by the Administrator, water shall be added by means of a controlled pressure feed distribution system located inside the mixing chamber of mixing equipment. The relative moisture ratio of the foamed bitumen stabilised material (RMR FB) shall not be less than 60% nor greater than 80%.

The moisture sample of stabilised materials shall be taken in accordance with Clause 9.6, following the stabilisation process and prior to commencing compaction. The relative moisture ratio value shall be calculated using the individual moisture content compared to the optimum moisture content for each corresponding location. The minimum testing frequency shall be as per Clause 1.2 of Annexure MRTS09.1.

8.10.3 Compaction standard

The characteristic value of the relative compactions shall be as stated in Clause 5 of Annexure MRTS09.1 or, where not so stated, shall not be less than 102% (standard compaction). This shall be achieved for the full thickness of each stabilised layer.

8.10.4 Geometrics

8.10.4.1 General

The stabilised layer(s) shall be constructed so as not to depart from the alignment, widths, thicknesses, lengths, heights and shapes specified in the Drawings or Contract by more than the tolerances stated in Clauses 8.10.4.2, 8.10.4.3 and 8.10.4.4.

8.10.4.2 Geometrics, vertical tolerances

8.10.4.2.1 Milling

The actual depth of milling at any point shall be no less than the depth specified and no greater than the specified depth plus 10 mm.

8.10.4.2.2 Primary tolerance – stabilised layers

A primary tolerance shall apply to the height of any point on the surface of the uppermost stabilised layer.

The primary tolerance shall be as stated in Clause 6.1 of Annexure MRTS09.1 as one of the alternatives in Table 8.10.4.2.2. If no such indication is given, the primary tolerance shall be Alternative A.

In all cases the nominated primary tolerance shall also apply to the thickness of a completed stabilised layer. Where multiple stabilised layers are constructed in the pavement structure, the thickness tolerance of the total stabilised layers shall be not less than -5 mm at any point.

Where a completed stabilised layer is required to be cut-back in accordance with Clause 8.9.9.3 prior to the overlay of the next layer of stabilised material, the thickness tolerance of the lower layer may be reduced to +/-10 mm at the Administrator's discretion to allow for the successful completion of the cut-back.

Table 8.10.4.2.2 – Primary tolerance for stabilised layers

Alternative	Primary Tolerance (mm)
A	-5 to +10
B	-5 to +15
C	Thickness Only

Alternative A (-5 to +10 mm) is recommended for the stabilised layer when the subsequent overlying layer is asphalt.

8.10.4.3 Geometrics, horizontal tolerances

The horizontal position of any point on the pavement or the edge of any milling shall not differ from the corresponding point shown on the Drawings or as otherwise specified in the Contract, calculated as described in Clause 8.10.4, by more than ± 50 mm, except where alignment of the pavement with an existing pavement or structure is necessary.

In this case, the new work shall be joined neatly to the existing work or structure in a smooth manner as shown on the Drawings or as otherwise specified in the Contract. If the Drawings or other Contract documents do not show, describe or specify how new work is to join to existing pavement or structures then it shall be done in a manner that is acceptable to and approved by the Administrator.

8.10.4.4 Additional tolerances

8.10.4.4.1 General

Additional tolerances shall apply to the pavement lots in the topmost stabilised layer(s) and the other stabilised layers specified in Clause 6.2 of Annexure MRTS09.1. For such lots the additional tolerances specified in Clauses 8.10.4.4.2, 8.10.4.4.3 and 8.10.4.4.4 shall apply.

The Contractor may have to carry out additional work to achieve these additional tolerances. No additional payment shall be made by the Principal for achieving such additional tolerances. Payment for any such work shall be deemed to be included in the Contractor's scheduled rate for the relevant items.

8.10.4.4.2 Deviation from a straight edge

The deviation from a 3 m long straight-edge placed anywhere on the surface of any layer to which this additional tolerance applies, shall not exceed the limit stated in Clause 6.3 of Annexure MRTS09.1, due allowance being made for design shape, where relevant. The limit stated in Clause 6.3 of Annexure MRTS09.1 shall be one of the alternatives given in Table 8.10.4.4.2.

Table 8.10.4.4.2 – Tolerance for deviation from a straight edge

Alternative	Primary Tolerance (mm)
D	5
E	8
F	15

8.10.4.4.3 Crossfall

The crossfall of any stabilised layer shall not depart from the corresponding crossfall shown in the Contract by more than 0.5% absolute.

The crossfall shall be measured:

- a) Between any two points more than two metres apart except where a pavement verge is less than two metres wide. For pavement verges less than two metres wide, the measurement shall be made between the extreme edges of the pavement verge on each side of the pavement.
- b) Transverse to the centre line of the carriageway, and
- c) Within the boundaries of a cross-section element that has a constant crossfall.

8.10.4.4.4 Surface evenness

The surface evenness of any stabilised layer to which this additional tolerance applies shall be such as to provide a road roughness count rate not exceeding the specified road roughness (R_s) stated in Clause 6.4 of Annexure MRTS09.1 or, where not so stated, not exceeding 50 counts per kilometre.

9 Construction compliance testing

Unless otherwise stated in this Technical Specification, the selection of sampling or test locations shall be carried out using random stratified sampling. Exceptions include testing of:

- a) geometrics (Clause 9.3)
- b) the bituminous stabilising agent content (Clause 9.4)
- c) the secondary stabilising agent content (Clause 9.5)
- d) visible deflection of pavement layers (Clause 9.7), and
- e) surface evenness (Clause 8.10.6.3.3 and Clause 9.3).

The Contractor is responsible for performing sufficient tests to ensure that the pavement complies with the standards and requirements of this Technical Specification. However, the Contractor's testing program shall be such that the testing frequencies and number of tests are not less than those specified in Clause 5.4.

9.1 Process requirements

Where construction has been carried out using process requirements, checking for compliance with the specified requirements shall be carried out during and after the construction operation, as relevant. Except for compaction, compliance checking shall be carried out in accordance with Clause 5.4. If a process requirement is specified for compaction, the minimum testing frequencies and minimum number of tests for compaction specified in Clause 5.4 apply to trial sections and do not apply to other sections.

Notwithstanding this, the requirements of Clauses 8.7 and 8.7.2 shall apply.

9.2 Product standards

Where construction has been carried out using product standards, compliance testing of the pavement shall be undertaken for each lot.

If a product standard is specified, the minimum testing frequencies and minimum number of tests for compaction specified in Clause 5.4 apply. Notwithstanding this, the requirements of Clauses 8.7 and 8.7.3 shall apply.

9.3 Geometrics

All geometric tolerances, except for surface evenness, shall be checked at regular intervals not greater than those specified in Clause 5.4.

The surface evenness of a stabilised pavement layer shall be measured by road roughness as per Test Method Q708B, Q708C and Q708D. The minimum length of a lot for this test shall be 100 metres and the maximum length of a lot for this test shall be 500 metres.

9.4 Bituminous stabilising agent content

The bituminous stabilising agent content shall be recorded in accordance with frequencies stated in Table 5.4. The actual bituminous agent content percentage shall be calculated by comparing, the mass of bituminous material at 15°C (calculation provided in this clause) against the total converted dry mass of all foamed bitumen stabilised material produced and weighed over the calibrated weighbridge or approved secondary weighing device. The converted dry mass shall have subtracted the total mass of bituminous material used, the total mass of secondary agent used, and, the average moisture content of the foamed bitumen stabilised material.

In all cases the actual bituminous stabilising agent content shall be within the allowable tolerance specified in Clause 8.10.1.2.

All measurements shall be recorded and included in the quality records and reported to the Administrator. The record and report for each measurement per lot shall include:

- a) where the measurement was taken and the date and time of the measurement
- b) the average moisture content of the stabilised material in accordance with Clause 9.6 and Clause 8.10.2.
- c) the extents and dimensions of placement and construction
- d) the date and time of the start and end of production
- e) the total quantity (including any excess) of stabilised material produced between each measurement and/or during the whole period of production (weighed over the calibrated weighbridge or approved secondary weighing device)
- f) the quantity of bituminous stabilising agent incorporated into the material between each measurement and/or during the whole period of production
- g) the foaming properties of the bituminous stabilising agent at the start of production and at the addition of any bitumen to a tanker
- h) amount and added time of foaming agent, and
- i) the temperature of the bituminous stabilising agent in the tanker at the start and during production.

All records shall be such that the actual bitumen application rate for each lot and production shall be calculated at 15°C before production recommences. All volume conversions, in relation to changes in

temperature of bituminous materials shall be carried out in accordance with the relevant factors listed in Table 9.4 using the following formula:

$$V_B = V_{BH} \times F_T \quad \text{Or} \quad V_{BH} = V_B \div F_T$$

where: V_B = volume of bitumen at 15°C (in litre)
 V_{BH} = volume of bitumen in high temperature (in litre), immediately prior to incorporation to the materials to be stabilised, and
 F_T = factor in high temperature from Table 9.4.

The mass of bitumen is then calculated from the volume of bitumen content using the following formula:

$$M_B = V_B \times 1.04 \quad \text{Or} \quad V_B = M_B / 1.04$$

where: M_B = mass of bitumen (kg)
 V_B = volume of bitumen at 15°C (in litre)

Table 9.4 – Equivalent volumes at 15°C of 1 litre of bituminous material measured at higher temperatures

Temp (°C)	Factor	Temp (°C)	Factor	Temp (°C)	Factor
15	1	80	0.9597	145	0.9207
20	0.9969	85	0.9566	150	0.9177
25	0.9938	90	0.9536	155	0.9148
30	0.9907	95	0.9506	160	0.9118
35	0.9876	100	0.9476	165	0.9089
40	0.9844	105	0.9446	170	0.906
45	0.9813	110	0.9416	175	0.9031
50	0.9782	115	0.9385	180	0.9002
55	0.9751	120	0.9355	185	0.8973
60	0.972	125	0.9326	190	0.8945
65	0.9689	130	0.9296	195	0.8916
70	0.9658	135	0.9266	200	0.8888
75	0.9627	140	0.9236	205	0.886

9.5 Secondary stabilising agent content

The secondary stabilising agent content shall be recorded in accordance with frequencies stated in Table 5.4. The actual secondary stabilising agent content percentage shall be calculated by comparing, the mass of secondary stabilising agent used against the total converted dry mass of all foamed bitumen stabilised material produced and weighed over the calibrated weighbridge. The converted dry mass shall have subtracted the total mass of bituminous material used, the total mass

of secondary agent used, and, the average moisture content of the foamed bitumen stabilised material.

The measurements shall be taken from the silo load cells or other method approved by the Administrator. In all cases the actual secondary stabilising agent content shall be within the allowable tolerance specified in Clause 8.10.1.2.

All measurements shall be recorded and included in the quality records and reported to the Administrator. The record and report for each measurement per lot shall include:

- a) where the measurement was taken and the date and time of the measurement
- b) the extents and dimensions of placement and construction
- c) the date and time of the start and end of production
- d) the quantity of stabilised material produced between each measurement and during the whole period of production
- e) the quantity of secondary stabilising agent incorporated into the material to be stabilised between each measurement and during the whole period of production, and
- f) the average of the actual quantity of material to be stabilised incorporated during production.

9.6 Compaction

Where construction has been carried out using product standards, the compaction standard for each lot or trial section shall be represented by the characteristic value of relative compaction.

The characteristic value shall be calculated as stated in Clause 12 of MRTS01 *Introduction to Technical Specifications* using the individual relative compactions determined from testing of each lot or, for trial sections only, testing of each trial section.

The locations of all samples taken for the determination of reference density, insitu dry density and relative compaction shall be recorded in accordance with the approved contractor's quality plan.

Sampling of stabilised materials to determine the laboratory reference density as detailed in Test Method Q142A shall take place after completing manufacturing and mixing of the stabilised material but prior to the commencement of compaction of the stabilised material.

Following sampling, reference density testing shall be completed to a stage where laboratory compaction has been completed within three hours of the commencement of stabilisation for the corresponding lot. Additionally, following sampling, oven drying of any specimens used to determine the moisture content shall commence within two hours of the commencement of stabilisation for the corresponding lot.

The relative compaction of the stabilised material as detailed in Test Method Q140A shall be determined using the ratio of the compacted dry density to the maximum dry density in Clause 8 of Annexure MRTS09.1. The relative compaction shall be determined for the thickness of the stabilised layer completed within the allowable working time.

Where the Contractor elects to place and compact two layers of stabilised materials in a single shift not exceeding a total thickness of 300 mm, the relative compaction tests Q141B and Q141A may be undertaken for the full depth of the stabilised material.

9.7 Visible deflection of pavement layers

The objective visible deflection test specified in this clause shall apply to the each stabilised pavement layer, unless stated otherwise in Clause 7 of Annexure MRTS09.1. Testing for visible deflection shall only be undertaken in the presence of the Administrator and shall be undertaken prior to placement of any overlying pavement layer. Where movement is observed under proof rolling construction of any overlying pavement layer shall not proceed until the Administrator grants the Contractor permission to proceed (refer to Clause 9.8).

No trafficking shall be allowed until no visual deflection is observed. Additional curing time may be required prior to trafficking on the stabilised pavement.

Testing for visible deflection shall be undertaken using a vehicle with an 8.2 tonne (gross) axle load on a single axle with dual tyres. **Witness Point** Where the surface of any section of the stabilised layer displays visible deflection, in the opinion of the Administrator, as a result of the movement of such a vehicle over it, the Administrator may require the Contractor to carry out additional compliance testing to ensure that the affected section of the pavement layer complies with Clauses 8.10.2, 9.4, 9.5 and 9.6. No additional payment shall be made by the Principal for such additional testing.

Where the Contractor elects to place and compact two (or more) stabilised layers in a single work shift, the visible deflection requirement on the surface of the lower layer(s) may be admitted by the Administrator to allow for the completion of the works, provided the Contractor meets the following criteria:

- the visible deflection observed shall not be excessive, and
- each layer of stabilised material is shown to comply with Clauses 8.10.1.2, 8.10.2, 8.10.3, and 8.10.4.

The above shall not apply when overlaying a stabilised material layer which is defined in the Contract / Drawings as an 'improved layer' or 'working platform'.

9.8 Acceptance

Construction shall not proceed until the Administrator has received the results of compliance testing for all lots constructed in the preceding two working days, except where less than two working days have passed since the commencement of stabilisation works.

No stabilised pavement lot shall be covered by a subsequent layer of pavement or by a surfacing until all testing has been completed and the layer has been presented to the Administrator for permission to proceed. **Hold Point 10**

10 Supplementary requirements

Notwithstanding the requirements specified in Clauses 1 to 9 they are varied by the supplementary requirements given in Clause 18 of Annexure MRTS09.1.

Superseded