

Technical Note 220

Requirements for Advance Warning Signals

February 2026

Copyright

© The State of Queensland (Department of Transport and Main Roads) 2026.

Licence



This work is licensed by the State of Queensland (Department of Transport and Main Roads) under a Creative Commons Attribution (CC BY) 4.0 International licence.

CC BY licence summary statement

In essence, you are free to copy, communicate and adapt this work, as long as you attribute the work to the State of Queensland (Department of Transport and Main Roads). To view a copy of this licence, visit: <https://creativecommons.org/licenses/by/4.0/>

Translating and interpreting assistance



The Queensland Government is committed to providing accessible services to Queenslanders from all cultural and linguistic backgrounds. If you have difficulty understanding this publication and need a translator, please call the Translating and Interpreting Service (TIS National) on 13 14 50 and ask them to telephone the Queensland Department of Transport and Main Roads on 13 74 68.

Disclaimer

While every care has been taken in preparing this publication, the State of Queensland accepts no responsibility for decisions or actions taken as a result of any data, information, statement or advice, expressed or implied, contained within. To the best of our knowledge, the content was correct at the time of publishing.

Feedback

Please send your feedback regarding this document to: tmr.techdocs@tmr.qld.gov.au

1 Background

Advance Warning Signals (AWS) are conspicuity devices used in conjunction with signage to alert road users about an upcoming hazard or changes in traffic condition. They provide the travelling public with more time to react as they approach the upcoming risk. For example, they can be used to draw attention to the following:

- traffic signals
- motorway ramp metering
- school zones
- emergency vehicles, and
- regulatory signs.

The AWS consist of 2 flashing yellow signals (conspicuity devices) accompanied by a sign which can be static, internally illuminated, changeable message, or variable message. The flashers illuminate in an alternating sequence and are activated when the hazard is present. Refer to the Queensland *Manual of Uniform Traffic Control Devices* (Queensland MUTCD) Part 1 for more information on signs on which AWS can be installed.

2 Scope

2.1 In scope

This document covers AWS that are controlled by a traffic signal controller. This includes, but is not limited to:

- Warning signs – alerts road user about an upcoming hazard, such as needing to stop at the upcoming intersection
- Direction signs – provides information to the road user, such as a build-up of traffic, and
- Regulatory signs – alerts road user about a current change in road condition that is enforceable, such as restricting right turns during specific times of the day.

Different use cases will require different monitoring and fault behaviour. This document will detail these requirements.

2.2 *Out of scope*

AWS operations already covered by a Transport and Main Roads Technical Specification are not within scope of this document. These include:

- MRTS202 *Variable Message Signs*
- MRTS218 *Vehicle Activated Signs (VAS)*, and
- MRTS222 *Enhanced School Zone Signs*.

3 **Advanced Warning Signals hardware**

AWS lanterns comply with MRTS253 *Traffic Signal Lanterns* when considering the yellow aspect. The use of target boards is supported for AWS. A separate flasher unit is used to drive the AWS. Where controlled by a SWARCO ITC-3 controller, a digital output shall be used to control the timing of the operation of the AWS. Refer to Appendix A for wiring details of the relay for control the AWS. When controlled by a Tyco Eclipse or ATC ATSC4 controller, a special purpose output can be used to control the timing of the operation of the AWS.

3.1 *Operation*

AWS will have:

- a) alternating flash sequence of each element
 - i. for a system with 4 flashing elements, diagonal element will be grouped together (to be driven at the same time)
- b) 1 Hz flash rate $\pm 10\%$, and
- c) 50% duty cycle $\pm 5\%$.

3.2 Use cases

Figure 3.2 – Example of advance warning signals



Used in conjunction with Warning Signs (left), Direction Signs (centre), and Regulatory Signs (right).

3.2.1 Warning signs

AWS are used in conjunction with warning signs. Warning signs are used to warn the road users of potential hazards on or adjacent to the road. A typical example where AWS are used in conjunction with warning signs is on the approach to a signalised intersection where there is insufficient safe sight stopping distance. In this case, the AWS alert road users of the potential hazard such that they can take action to prevent a collision.

For this use case, the AWS is active default and only deactivates when needed as per the site-specific drawings.

When controlled by a SWARCO ITC-3 controller, the flasher unit for the AWS is controlled by a relay (R3) which is supplied from the input of the field active relay (R1). Relay R3 for AWS uses a Normally Closed (NC) contact.

When controlled by a Tyco Eclipse or ATC ATSC4 controller, the flasher unit for the AWS is controlled by a relay which is supplied from the input of the master relay. The relay for AWS uses a Normally Closed (NC) contact.

The wiring arrangement ensures the AWS will be operating if the controller is in fault mode as the hazard can still exist.

The cabling from the controller to the AWS shall have a dedicated cable run.

3.2.2 Direction signs

AWS are used in conjunction with advisory signs such as ramp metering signs advising motorist that metering onto the motorway is active and they may experience delays.

For this use case the AWS is active only when needed as per the site-specific drawings.

When controlled by a SWARCO ITC-3 controller the flasher unit for the AWS is controlled by a relay (R4) which is supplied from the output of the field active relay (R1). Relay R4 for AWS uses a Normally Open (NO) contact.

When controlled by a Tyco Eclipse or ATC ATSC4 controller the flasher unit for the AWS is controlled by a relay which is supplied from the output of the master relay. The relay for AWS uses a Normally Open (NO) contact.

3.2.3 Regulatory signs

AWS are used in conjunction with regulatory signs, for example, a part-time right-turn ban, to draw the motorist's attention to the changed conditions.

For this use case the AWS is active only when needed as per the site-specific drawings.

When controlled by a SWARCO ITC-3 controller the flasher unit for the AWS is controlled by a relay (R4) which is supplied from the output of the field active relay (R1). Relay R4 for AWS uses a Normally Open (NO) contact.

When controlled by a Tyco Eclipse or ATC ATSC4 controller the flasher unit for the AWS is controlled by a relay which is supplied from the output of the master relay. The relay for AWS uses a Normally Open (NO) contact.

4 Reference documents

- Department of Transport and Main Roads Technical Specification MRTS252 *Next Generation Traffic Signal Controllers*, Brisbane, QLD
- Department of Transport and Main Roads Technical Specification MRTS253 *Traffic Signal Lanterns*, Brisbane, QLD
- Department of Transport and Main Roads Technical Specification MRTS255 *Traffic Signal Controllers*, Brisbane, QLD

Appendix A: Advance warning signals example drawings

Department of Transport and Main Roads MRT_Detail (06/19)

Notes

1. New AWS terminals to be supplied by SWARCO as a standard kit, including all terminals, wiring loom and wiring/installation detail.
2. AWS-1 and AWS-N supplied from LV/ELV Patch Terminals Refer SWARCO wiring detail.
3. Terminal AWS 1 includes 2A fuse.
4. AWS cabling shall be a separate cable.
5. AWS multicore cable shall be determined by design, including Voltage Drop, Fault Loop Impedance and Current Carrying Capacity calculations. All unused cores to earth.
6. Output # shall be the next available digital output on the controller.

CONTROLLER STN EQUIPMENT MATERIAL LIST				
ITEM	Description	Details	Manufacturer Part No. (Or equivalent)	Quantity
1	AWS CONTROL KIT	SWARCO OEM KIT	30034143	1

SWARCO OEM Kit includes:-
 Group Marker Carrier with "AWS" insert - 1 x WAGO 2009-163
 Screwless End Stops - 2 x WAGO 249-116
 24VDC Relay - 1 x Finder 96-02 and 1 x Finder 56.32.9.024.0074
 Flasher Relay - 1 x BRAUMS BFA042A
 4 conductor fuse terminal block - 1 x WAGO2202-1811
 4 conductor through terminal block - 1 x WAGO 2204-1401

CONTROLLER ESCUTCHEON

LV/ELV PATCH TERMINALS Refer Inset 2
 NEW AWS TERMINALS Refer Inset 1
 42VAC Flasher Relay

INSET 1 - AWS TERMINAL ARRANGEMENT

ET-T
 AWS 2A FUSE
 Supplied from LV/ELV Patch Terminals (42VAC)
 R2
 C Block Lamp Outputs below.

INSET 2 - LV-ELV PATCH TERMINALS

CONTROLLER

LV-ELV PATCH TERMINALS (refer inset 2)
 AWS TERMINALS (refer inset 1)
 2A FUSE
 AWS-1
 AWS-N
 RELAY (R2) NORMALLY CLOSED
 42VAC FLASHER
 TO DIGITAL OUTPUT #
 Pole Upper Mounting Assembly

Multi Core Cable Note 4 and 5

Example Only

G		Associated Job No.	Survey Date	BCC	ADVANCE WARNING SIGNALS - LOCAL FLASHER	Site Number	
F		Horiz. Datum			CRITICAL CONTROL (FAIL ON)		
E		Auxiliary Drg Nos		CTL CHGE	Wiring Connection Detail		
D							
C							
B							
A							
Approved for use Revisions/Descriptions Drawn Checked Signed Date				ORIGINAL SIZE A3 Dimensions shown in Not to scale except where shown otherwise Through Change from	Reference Points Preceding RP Dist. to start of job (km) From start to end of job From end to Following RP	Drawn Designed Checked	ENGINEERING CERTIFICATION (RPEQ) NAME SIGNATURE No. DATE Job No. Contract No. Drawing No. Series Number

1 of 8

Notes

1. New AWS terminals to be supplied by SWARCO as a standard kit, including all terminals, wiring loom and wiring/installation detail.
2. AWS-1 and AWS-N supplied from LV/ELV Patch Terminals Refer SWARCO wiring detail.
3. Terminal AWS 1 includes 2A fuse.
4. AWS cabling shall be a separate cable.
5. AWS multicore cable shall be determined by design, including Voltage Drop, Fault Loop Impedance and Current Carrying Capacity calculations. All unused cores to earth.
6. Output # shall be the next available digital output on the controller.

ITEM	Description	Details	Manufacturer Part No. (Or equivalent)	Quantity
1	AWS CONTROL KIT	SWARCO OEM KIT	30034144	1

SWARCO OEM Kit includes:-
 Group Marker Carrier with "AWS" insert - 1 x WAGO 2009-163
 Screwless End Stops - 2 x WAGO 249-116
 24VDC Relay - 1 x Finder 96-02 and 1 x Finder 56.32.9.024.0074
 Flasher Relay - 1 x BRAUMS BFA042A
 4 conductor fuse terminal block - 1 x WAGO2202-1811
 4 conductor through terminal block - 1 x WAGO 2204-1401

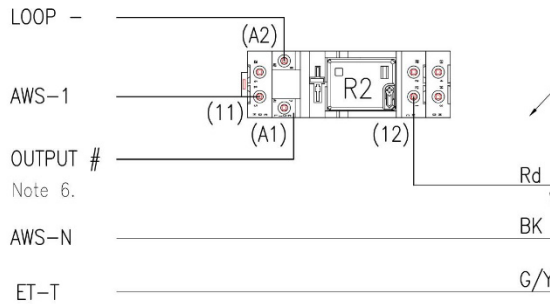
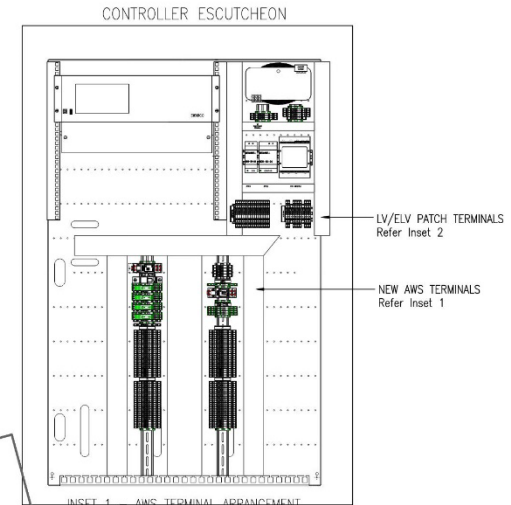

Example Only

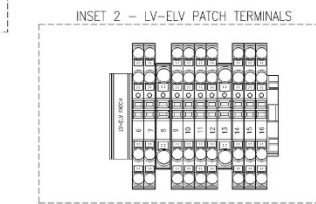
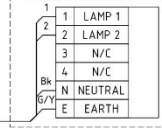
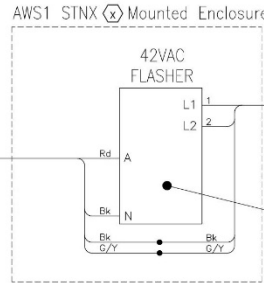
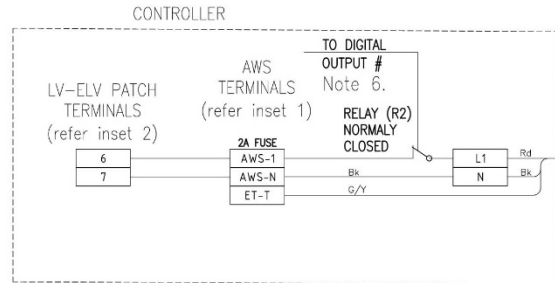
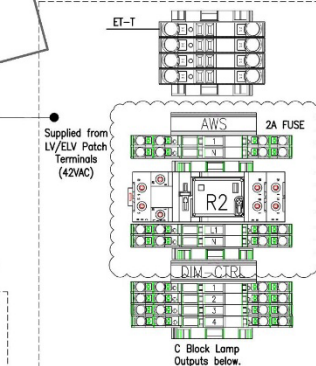

Last Modified: 17 Feb 17, 2026 - 4:01 PM

G		Associated Job Nos		Survey Data		BCC		ADVANCE WARNING SIGNALS - REMOTE FLASHER		Site Number		
F		Auxiliary Drg Nos		Horiz. Datum		CTL CHGE		CRITICAL CONTROL (FAIL ON)				
E				Horiz. Grid		Reference Points		Wiring Connection Detail		ENGINEERING CERTIFICATION (RPEQ)		
D				Height Datum		Preceding RP		Drawn		ENG. AREA		
C				Survey Books		Dist. to start of job (km)		Designed		NAME		
B				Dimensions shown in Not to scale except where shown otherwise		From end to end of job		Checked		SIGNATURE		
A		Approved for use				From end to Following RP		###		No.		
		Revisions/Descriptions								DATE		
		Drawn								###		
		Checked										
		Signed										
		Date										

Notes

1. AWS circuit protection provided by FA1-3 2A fuse.
2. AWS cabling shall be a separate cable.
3. AWS multicore cable shall be determined by design, including Voltage Drop, Fault Loop Impedance and Current Carrying Capacity calculations. All unused cores to earth.
4. Output # shall be the next available digital output on the controller.

CONTROLLER STN EQUIPMENT MATERIAL LIST				
ITEM	Description	Details	Manufacturer Part No. (Or equivalent)	Quantity
1	AWS CONTROL KIT	SWARCO OEM KIT	30034145	1

SWARCO OEM Kit includes:-
 Group Marker Carrier with "AWS" insert - 1 x WAGO 2009-163
 Screwless End Stops - 2 x WAGO 249-116
 24VDC Relay - 1 x Finder 96-02 and 1 x Finder 56.32.9.024.0074
 Flasher Relay - 1 x BRAUMS BFA042A
 Bootlaced wiring to size, labeled.

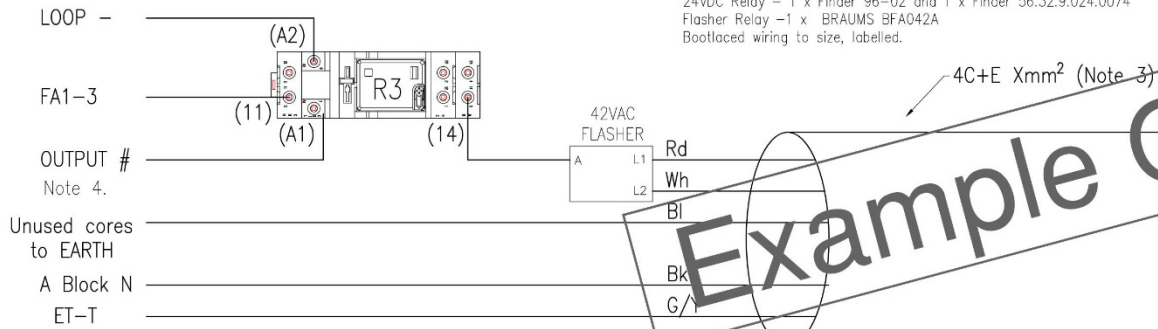
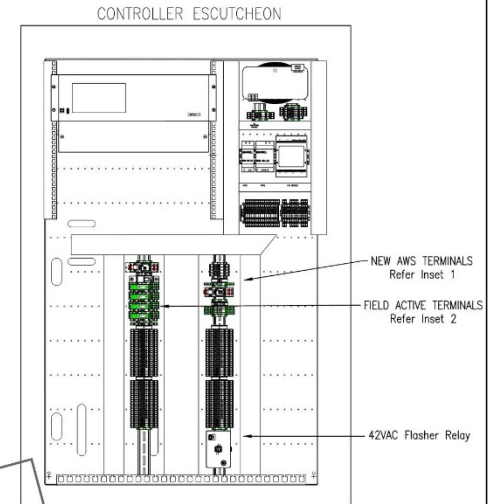

Example Only

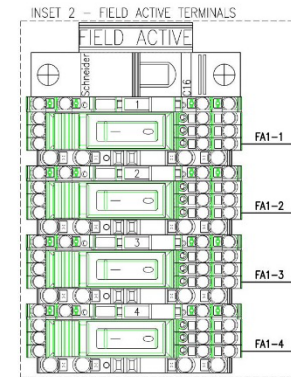
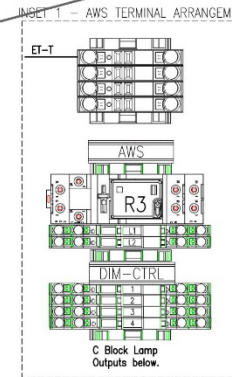
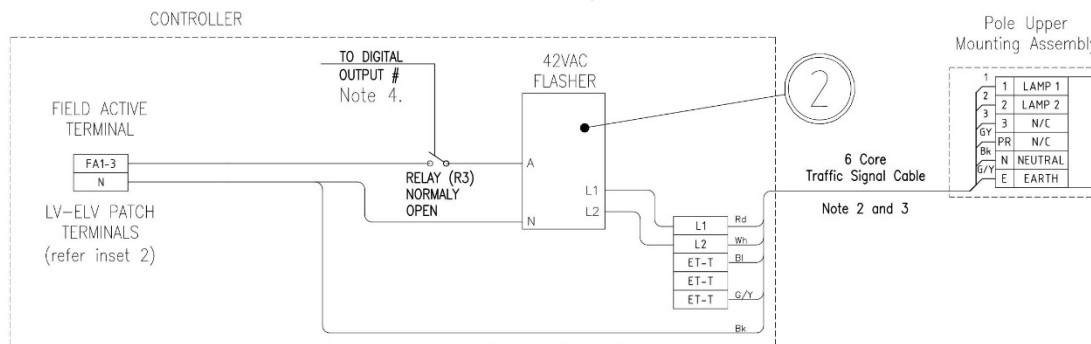

G F E D C B A	Associated Job Nos Survey Data Horiz. Datum Horiz. Grid Height Datum Survey Books	BCC ADVANCE WARNING SIGNALS - LOCAL FLASHER INDEPENDENT CONTROL (FAIL OFF) Wiring Connection Detail	Site Number Job No. Contract No. Series Number	
	Revisions/Descriptions Drawn Checked Signed Date	ORIGINAL SIZE A3 Preceding RP Dist. to start of job (km) From start to end of job From end to Following RP Following RP	Drawn Designed Checked	ENGINEERING CERTIFICATION (RPEQ) ENG. AREA NAME SIGNATURE No. DATE
	Approved for use	Dimensions shown in Not to scale except where shown otherwise	Through Change from	Drawing No. ### A 5 of 8
	CAD FILES C:\Users\cswat01\OneDrive - TMR\OneDrive\Projects\NewGen\Controller Cabinet\AutoCAD\SWARCO AWS Design\00_PDU\ELV Advance Flashers 2026_02_17 PDU.dwg			

Notes

1. AWS circuit protection provided by FA1-3 2A fuse.
2. AWS cabling shall be a separate cable.
3. AWS multicore cable shall be determined by design, including Voltage Drop, Fault Loop Impedance and Current Carrying Capacity calculations. All unused cores to earth.
4. Output # shall be the next available digital output on the controller.

CONTROLLER STN EQUIPMENT MATERIAL LIST				
ITEM	Description	Details	Manufacturer Part No. (Or equivalent)	Quantity
1	AWS CONTROL KIT	SWARCO OEM KIT	3003146	1

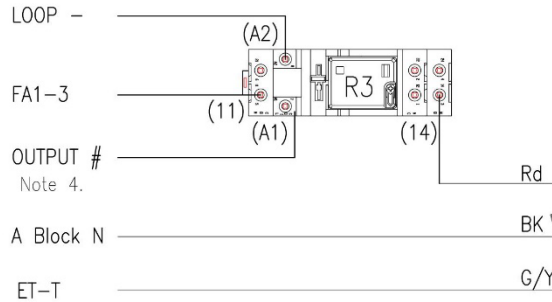
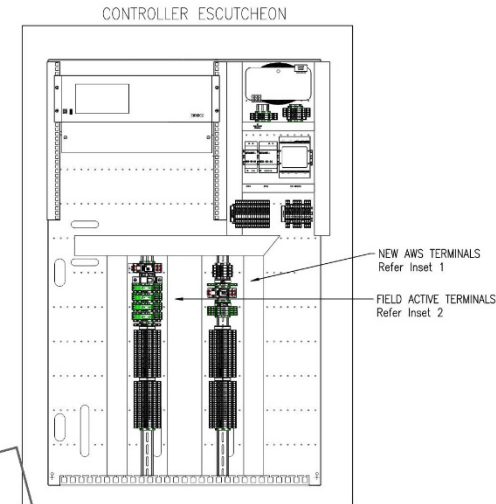

Example Only

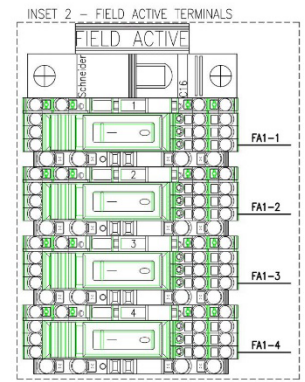
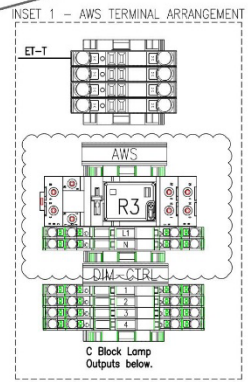
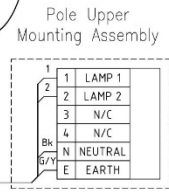
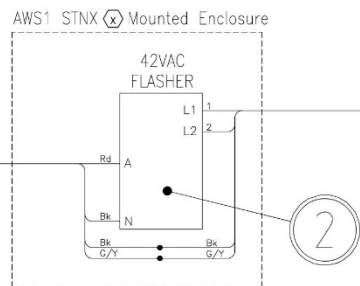
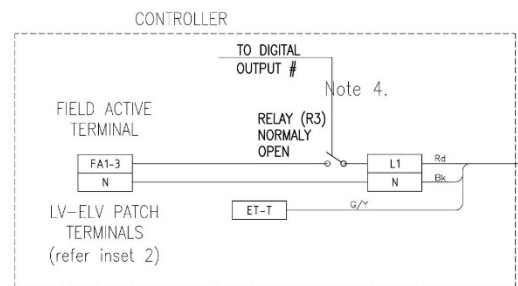

G		Associated Job Nos		Survey Data		BCC		ADVANCE WARNING SIGNALS - REMOTE FLASHER		Site Number		
F		Auxiliary Drg Nos		Horiz. Datum		CTL CHGE		INDEPENDENT CONTROL (FAIL OFF)				
E				Horiz. Grid		Reference Points		Wiring Connection Detail				ENGINEERING CERTIFICATION (RPEQ) ENG. AREA NAME SIGNATURE No. DATE #####
D				Height Datum		Preceding RP Dist. to start of job (km) From start to end of job From end to Following RP Following RP		Drawn				
C				Survey Books		Dimensions shown in Not to scale except where shown otherwise		Designed				Drawing No. ##### A
B								Checked				
A		Approved for use										

Last Modified: 11 Feb 17, 2026 - 4:01 PM

CONTROLLER STN EQUIPMENT MATERIAL LIST				
ITEM	Description	Details	Manufacturer Part No. (Or equivalent)	Quantity
1	4RU RACK MOUNT DIN RAIL	MADISON	MT19154RUDIN	1
2	REMOTE TELEMETRY	ELPRO 905-U	EL-905U-1-900	1
3	AWS CONTROL KIT	SWARCO OEM KIT	30034147	1
4	FUSE/LINK TERMINAL	WEIDMULLER - 1 Pair	WSI-6 / WTR2.5	1
5	POWER SUPPLY	MEANWELL 24VDC 40W	MDR-40-24	1

NOTE:
4RU RACK MOUNT DIN RAIL TO BE INSTALLED IN RACK SPACE BELOW CONTROLLER MODULE.

SWARCO OEM Kit includes:-
Group Marker Carrier with "AWS" insert - 1 x WAGO 2009-163
Screwless End Stops - 2 x WAGO 249-116
24VDC Relay - 1 x Finder 96-02 and 1 x Finder 56.32.9.024.0074
Bootlaced wiring to size, labelled.

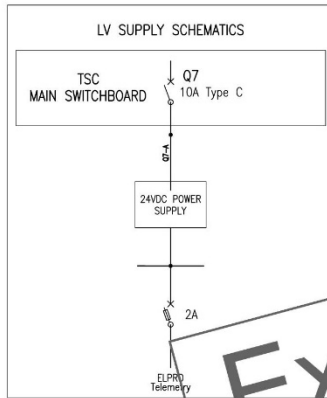

Example Only

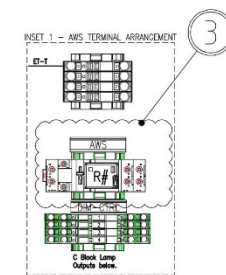
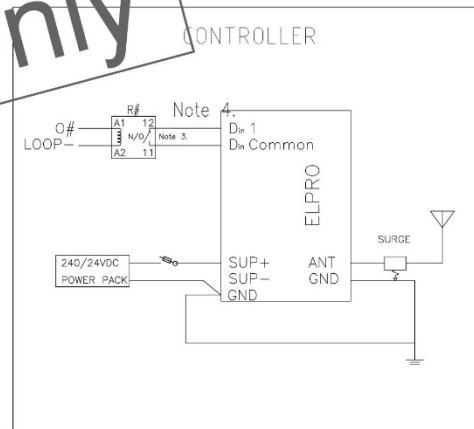
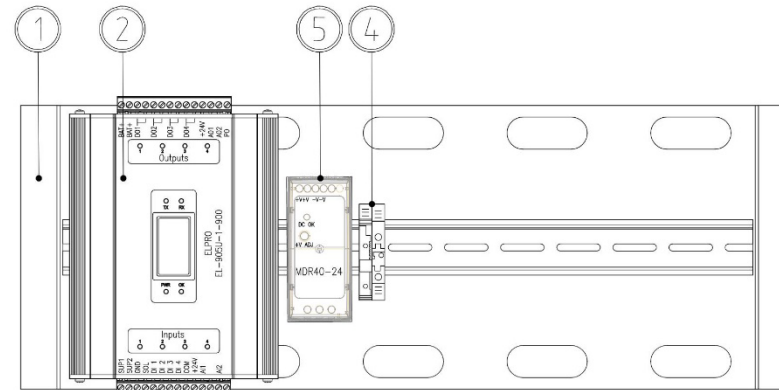

Notes

- Each site shall be independently RPEQ certified by the designer.
- For AWS Pole connection detail, refer Pole Mounted Junction Box detail with relevant SWB location requirement.
- R# designation is as follows:-
 - R2 for Critical Control - Normally Open
 - R3 for Independent Control (Fail Off) - Normally Open
- Output O# shall be the next available digital output on the controller.

Last Modified: --, Feb 17, 2024, - 4:02pm XREFS: --

Associated Job Nos		Survey Data		BCC		ADVANCE WARNING SIGNALS REMOTE TELEMETRY AWS WARNING SIGN CONTROLLER CONNECTION DETAIL		Site Number			
Auxiliary Drg Nos		Horiz. Datum		CTL CHGE		ENGINEERING CERTIFICATION (RPEQ)		Job No.		Contract No.	
A Approved for use		Horiz. Grid		Reference Points		Drawn		No.		DATE	
Revisions/Descriptions		Height Datum		Preceding RP		Designed		NAME		SIGNATURE	
Drawn		Survey Books		Dist. to start of job (km)		Checked		No.		DATE	
Checked		ORIGINAL SIZE A3		From start to end of job		###		###		###	
Signed		Dimensions shown in Not to scale except where shown otherwise		From end of Following RP		###		###		###	
Date		Through Change from		Following RP		###		###		###	
Date										Drawing No. ### A	
										Series Number 5 of 8	

AWS STN EQUIPMENT MATERIAL LIST				
ITEM	Description	Details	Manufacturer Part No. (Or equivalent)	Quantity
1	FLASHER RELAY	BRAUMS	BFA042A	1
2	REMOTE TELEMETRY	ELPRO 905-U	EL-905U-1-900	1
3	24VDC RELAY	FINDER RELAY AND BASE	RELAY 56.32.9.024.0074 BASE 96.02	1
4	TERMINALS	WAGO	2202-1811 (Fused Active) 2202-1401 (Neutral) 2206-1307 (Earth)	2 4 3
5	AWS ENCLOSURE	IP66 JUNCTION BOX	PC362717	1
6	TRANSFORMER	230VAC/42VAC	TO300-240-42	1
7	POWER SUPPLY	MEANWELL 24VDC	HDR-60-24	1

Notes

- Each site shall be independently RPEQ certified by the designer.
- Refer CONTROLLER CONNECTION DETAIL drawing for remote telemetry equipment installed in Traffic Signal Controller.
- R# shall be:-
 - R2 - NORMALLY CLOSED for AWS Critical Control
 - R3 - NORMALLY OPEN for AWS Independent Control

Example Only

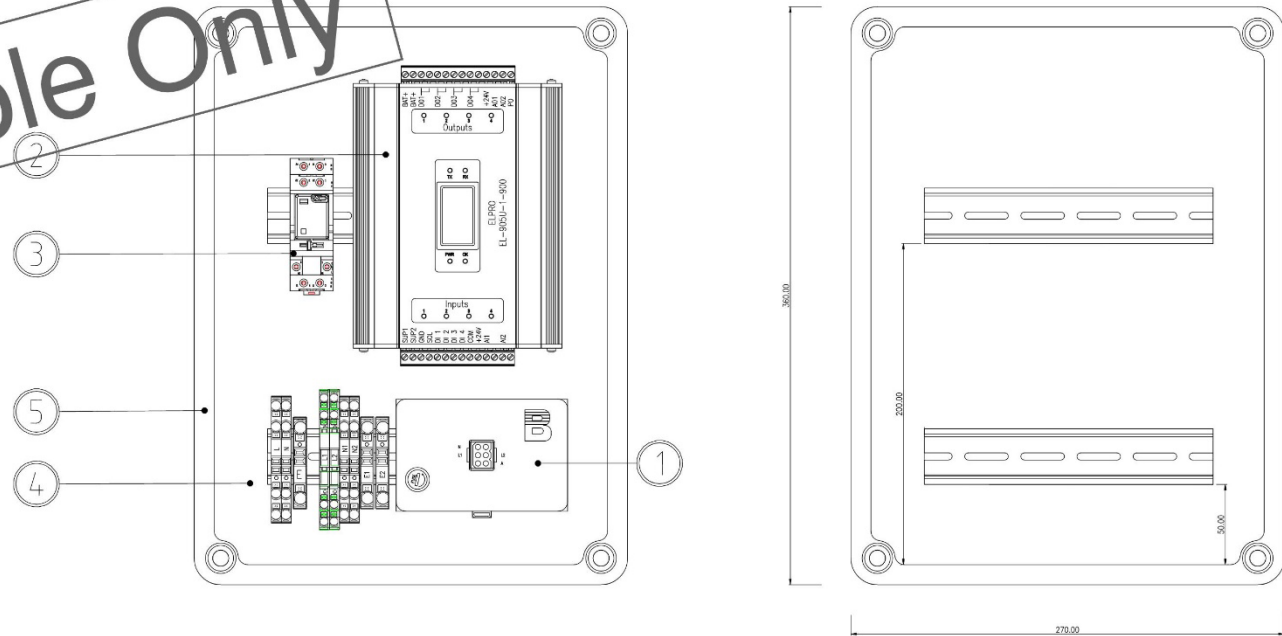
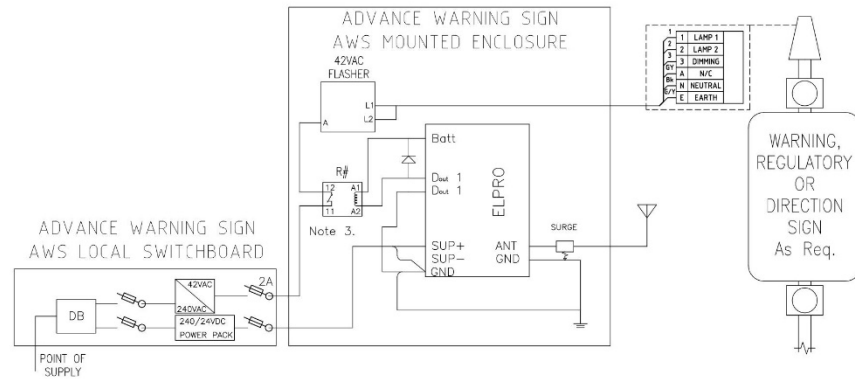

C F E D C B A	Associated Job Nos	Survey Data	BCC				Site Number	Queensland Government
	Auxiliary Drg Nos	Horiz. Datum	CTL CHGE				Job No.	
Approved for use	Revisions/Descriptions	Drawn	Checked	Signed	Date	Reference Points Preceding RP Dist. to start of job (km) From start to end of job From end to Following RP Following RP		ENGINEERING CERTIFICATION (RPEQ) Drawn ENG. AREA NAME SIGNATURE No. DATE
ORIGINAL SIZE A3 Dimensions shown in Not to scale except where shown otherwise						Contract No. ##### A Series Number 6 of 8		

AWS STN EQUIPMENT MATERIAL LIST				
ITEM	Description	Details	Manufacturer Part No. (Or equivalent)	Quantity
1	FLASHER RELAY	BRAUMS	BFA042A	1
2	REMOTE TELEMETRY	ELPRO 905-U	EL-905U-1-900	1
3	24VDC RELAY	FINDER RELAY AND BASE	RELAY 56.32.9.024.0074 BASE 96.02	1
4	TERMINALS	WAGO	2202-1811 (Fused Active) 2202-1401 (Neutral) 2206-1307 (Earth)	2 2 2
5	AWS ENCLOSURE	IP66 JUNCTION BOX	PG362717	1
6	TRANSFORMER	230VAC/42VAC	GAYRAD 1Ph TO60VA	1
7	POWER SUPPLY	MEANWELL 24VDC	HDR-60-24	1
8	DIN RAIL	35mm DIN RAIL	Length - 80mm	1
9	CUSTOM BRACKET	1.5mm FOLDED ZINC PLATE	70X110X120mm	1
10	DIN RAIL	35mm DIN RAIL	Length - 110mm	3
11	TERMINAL BLOCK	NEUTRAL/EARTH BLOCKS		2
12	ISOLATOR	MAIN SWITCH	REFER SD1699 ITEM 585	1
13	CIRCUIT PROTECTION	FUSELINK 6A, 10X38 CFS 10X38 SINGLE POLE	SD1699 ITEM 433 SD1699 ITEM 411	1 1

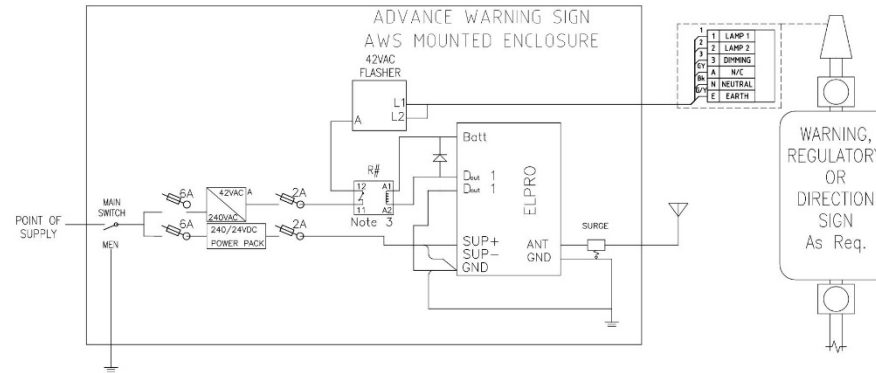

ELPRO CUSTOM BACKET - ISOMETRIC VIEWS

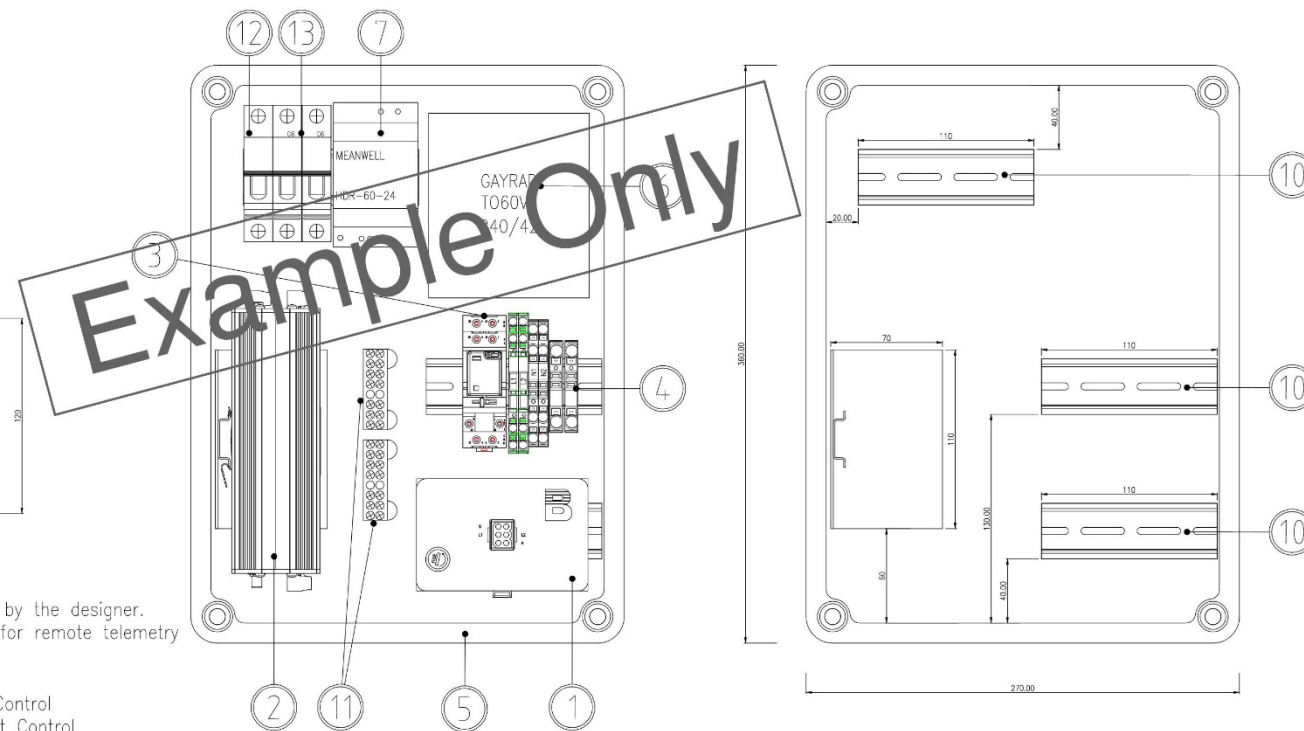
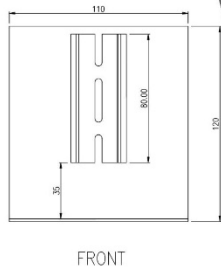
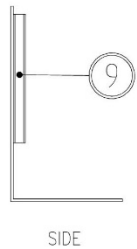
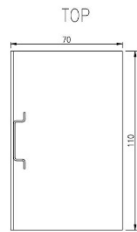

Notes

- Each site shall be independently RPEQ certified by the designer.
- Refer CONTROLLER CONNECTION DETAIL drawing for remote telemetry equipment installed in Traffic Signal Controller.
- R# shall be:-
 - R2 - NORMALLY CLOSED for AWS Critical Control
 - R3 - NORMALLY OPEN for AWS Independent Control

G F E D C B A	Associated Job Nos	Survey Data	BCC				Site Number	Queensland Government
	Auxiliary Drg Nos	Horiz. Datum Horiz. Grid Height Datum Survey Books	Reference Points Preceding RP Dist. to start of job (km) From start to end of job From end to Following RP Following RP				Job No.	
Approved for use	Drawn Checked Signed Date	ORIGINAL SIZE A3 Dimensions shown in Not to scale except where shown otherwise	Through Change from	Drawn Designed Checked	ENGINEERING CERTIFICATION (RPEQ)		Contract No.	
Revisions/Descriptions	Note 1	No. DATE	No. DATE	No. DATE	No. DATE	Drawing No.	Series Number	

