

**Technical Note 200**

# **Slip base pole clamping bolt tethering system installation**

**February 2026**

## Copyright

© The State of Queensland (Department of Transport and Main Roads) 2026.

## Licence



This work is licensed by the State of Queensland (Department of Transport and Main Roads) under a Creative Commons Attribution (CC BY) 4.0 International licence.

## CC BY licence summary statement

In essence, you are free to copy, communicate and adapt this work, as long as you attribute the work to the State of Queensland (Department of Transport and Main Roads). To view a copy of this licence, visit: <https://creativecommons.org/licenses/by/4.0/>

## Translating and interpreting assistance



The Queensland Government is committed to providing accessible services to Queenslanders from all cultural and linguistic backgrounds. If you have difficulty understanding this publication and need a translator, please call the Translating and Interpreting Service (TIS National) on 13 14 50 and ask them to telephone the Queensland Department of Transport and Main Roads on 13 74 68.

## Disclaimer

While every care has been taken in preparing this publication, the State of Queensland accepts no responsibility for decisions or actions taken as a result of any data, information, statement or advice, expressed or implied, contained within. To the best of our knowledge, the content was correct at the time of publishing.

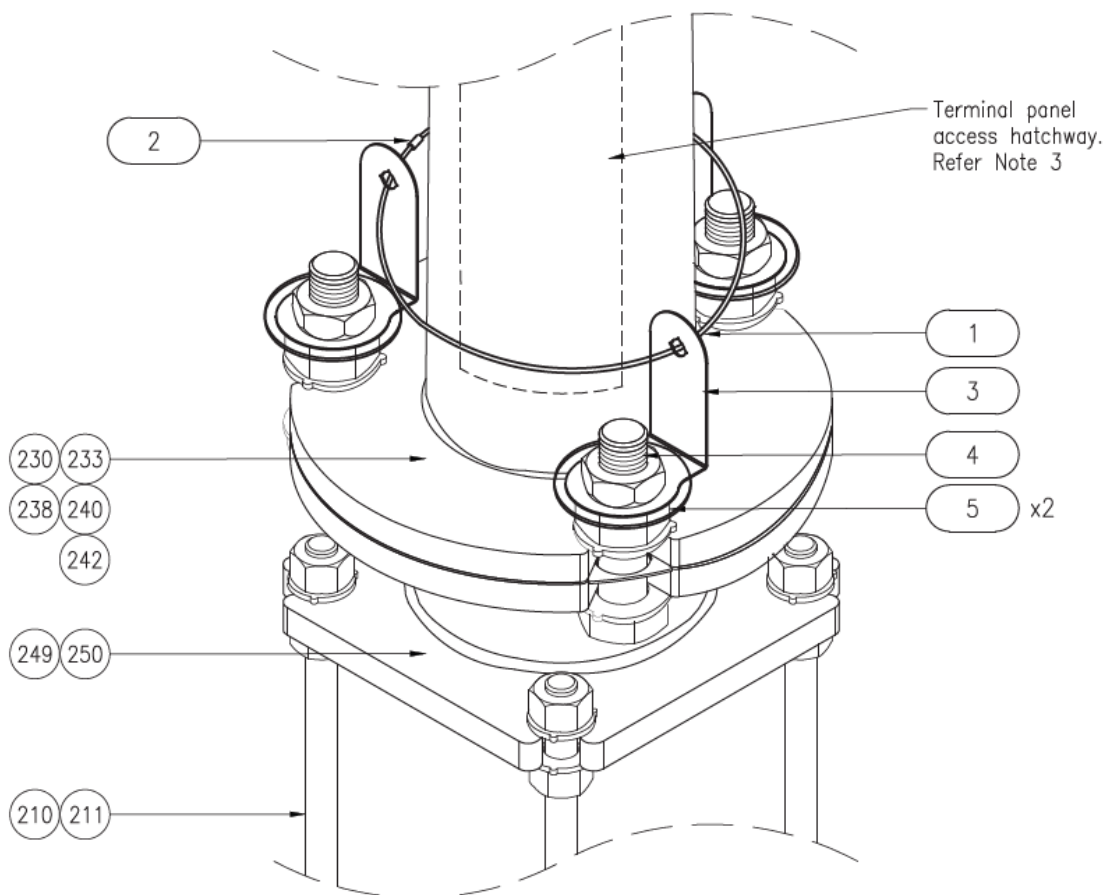
## Feedback

Please send your feedback regarding this document to: [tmr.techdocs@tmr.qld.gov.au](mailto:tmr.techdocs@tmr.qld.gov.au)

## 1 Purpose of Technical Note

This document provides guidance on the step-by-step instruction for the installation of slip base pole clamping bolt tethering system shown in Standard Drawing 1755 *Road Lighting – Slip Bolt Tethering System for TMR Rate 3 Slip Base Poles*. The tethering system has been implemented to minimise the risk of the clamping bolt being thrown out of the slip base pole if it is accidentally hit by a vehicle and which could potentially cause harm to other road users and damage vehicles and other road infrastructure.

**Figure 1 – Slip base pole clamping bolt tethering system installation**



## 2 Preparing for slip base pole clamping bolt tethering system installation

The following steps are to be taken before, during and after the installation of the slip base pole clamping bolt tethering system.

Obtain all documentation, materials, and tools required for the installation of the slip base pole clamping bolt tethering system listed as follows.

Note: The following lists are non-exhaustive and may require more documentation, and tools, to perform the installation work safely, accurately, and efficiently.

## 2.1 Tools



The following tools are required as a minimum to perform the clamping bolt tethering system installation for each slip base pole:


- 2 of adjustable wrench (recommended part #OX-P324612)
- 1 of swage crimping pliers (recommended part #HIT CT600/5)
- 1 of wire rope cutter (recommended part #HIT W16)
- 1 of brake and parts cleaner (recommended part #CT-BCNF-400)
- 1 of M36 x 130 mm bolt
- 1 of spring clamp
- thread sealing compound (recommended LOXEAL 58-11 thread sealant), and
- thread sealing compound activator (recommended LOXEAL anaerobic adhesive activator 11).

## 2.2 Materials

The following materials detailed in Table 2.2 are required to perform the slip base pole clamping bolt tethering system installation for each slip base pole.

**Table 2.2 – Materials details and illustrations**

Material	Illustration
1 of 7 x 7 grade 316 stainless steel 4 mm diameter wire rope (recommended part #WR-4M77316), cut length is 1450 mm	
1 of 4.0 nickel-plated copper, thick-walled swage (recommended part #MFWCM04N)	

Material	Illustration
3 of grade 304 stainless steel 0.7 mm tear washer	
3 of M36 18 mm thick galvanised half nut (recommended part #Hobson NL08GCM36)	
6 of 0.25 mm thickness, 36 mm inner diameter and 80 mm outer diameter Mylar® washer	
Non-flammable brake & parts cleaner	

Material	Illustration
LOXEAL 58-11 thread sealant	
LOXEAL Activator 11	

### 2.3 Documents

The following documents are **required** as a minimum to perform the slip base pole clamping bolt tethering system installation:

- Transport and Main Roads [Technical Note](#) 200 *Slip Base Pole Clamping Bolt Tethering System Installation* (this document), and
- Transport and Main Roads [Standard Drawing](#) 1755 *Road Lighting – Slip Bolt Tethering System for TMR Rate 3 Slip Base Poles*.

The following documents are **referenced** to perform the clamping bolt tethering system installation:

- Transport and Main Roads Standard Drawing 1380 *Road Lighting – Slip Base Mounted Pole – Footing Details for Installation in the Median*
- Transport and Main Roads Standard Drawing 1699 *Traffic Signals / Road Lighting / ITS – Parts List (Item 379)*, and
- [Australian Standard](#) AS 1275 *Metric screw threads for fasteners*.

### **3 Cleaning and clearing half nuts**

Before starting the assembly, obtain a M36 x 130 mm bolt and run all half nuts at least 50 mm down through the bolt one by one. Repeat the process several times to clear up the nuts. A non-flammable brake and parts cleaner (recommended brand is AutoChem™) should be used to clean the threads of half nuts.



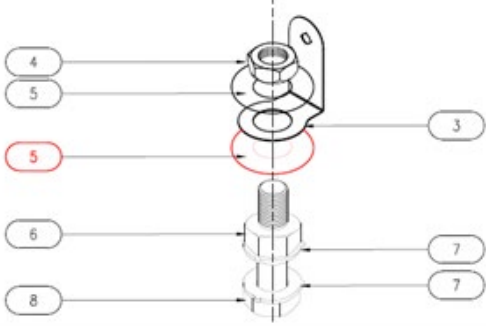

### **4 Locating slip base pole and clamping bolts**

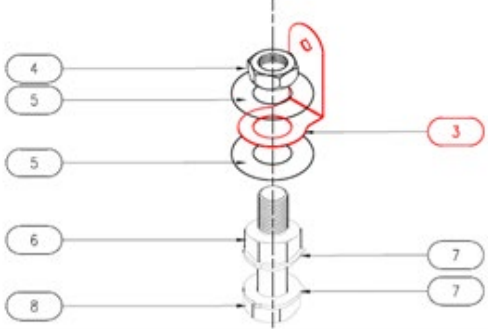

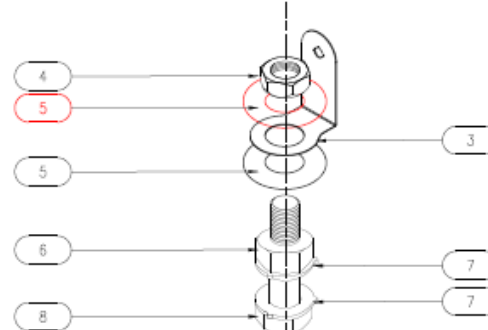

Locate the slip base pole and check slip base assembly is in good order. Clean up the surrounding area if required for any overgrown grass or weeds covering the clamping bolts.

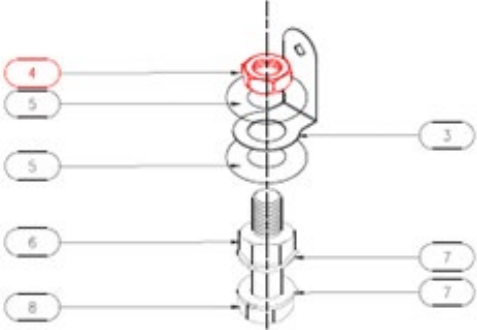



### **5 Assembly and installation**

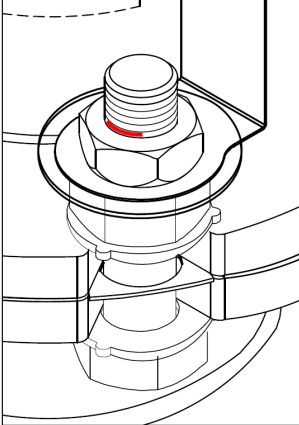

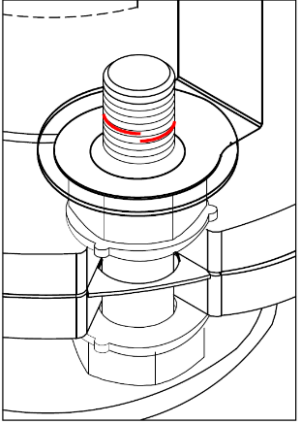

See Table 5 for steps of assembly and installation with illustrations and photographs.

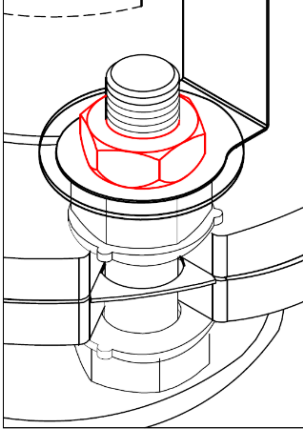

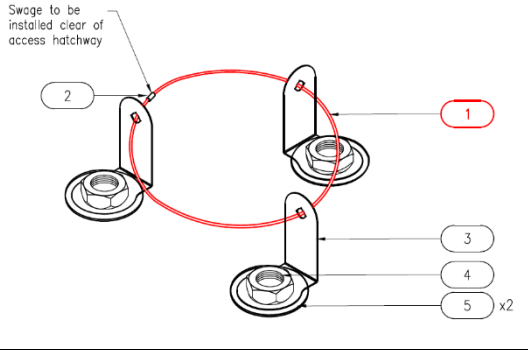
**Table 5 – Assembly and installation**

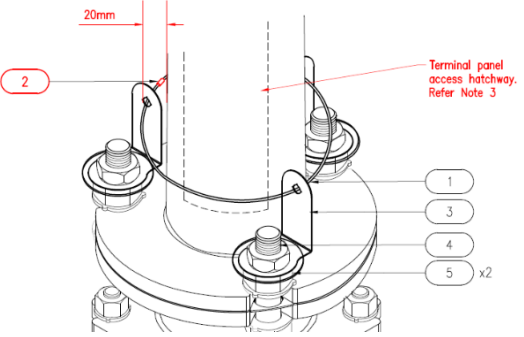

Step No.	Step title	Description	Illustration	Photograph
1.	Clean the threads	Spray the brake and parts cleaner to the thread inside the half nut and the exposed thread at the top of the clamping bolt.		
2.	First Mylar® washer assembly	Place the first Mylar® washer over one of the M36 clamping bolt nuts.	 <p data-bbox="1240 1230 1637 1262"><i>First Mylar® washer assembly</i></p>	


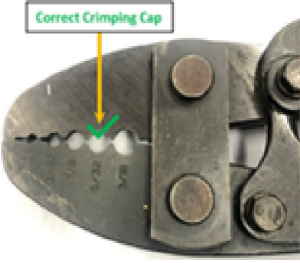

Step No.	Step title	Description	Illustration	Photograph
3.	Tear washer assembly	Place a tear washer over the Mylar® washer and orientate the tab to ensure the tear washer is clear of terminal panel access hatchway to ensure good access to hatchway.		
<i>Tear washer assembly</i>				
4.	Second Mylar® washer assembly	Place the second Mylar® washer over the tear washer.		
<i>Second Mylar® washer assembly</i>				





Step No.	Step title	Description	Illustration	Photograph
5.	First half nut assembly	<p>Place the first half nut over the Mylar® washer and finger tighten. Reorientate the tear washer as needed.</p> <p>Loosen the half nut one-quarter to one-third of a full turn to let the tear washer move freely and leave it in that position.</p> <p>If the nut is too stiff to screw in by hand, use an adjustable wrench to secure the nut below the taper, and then use another wrench to screw in the half nut.</p>	 <p>The diagram shows an exploded view of the assembly. Callout 4 points to a red Mylar washer. Callout 5 points to a silver tear washer. Callout 6 points to a silver half nut. Callout 8 points to a silver bolt. Callout 3 points to a metal plate. Callout 7 points to a tapered sleeve.</p>	 <p>A close-up photograph showing a person's hands working on the assembly. A silver half nut is being positioned over a bolt that has a tapered sleeve and a metal plate attached to it.</p>
6.	Apply thread-sealant activator	<p>Take the cleaned half nut and spray LOXEAL Activator 11 on inside threads of half nut.</p>	 <p>A small diagram showing a half nut with a red spray nozzle directed at its internal threads.</p>	 <p>A photograph showing a person's hand holding a half nut and spraying it with a white spray bottle. The spray is directed at the internal threads of the half nut.</p>

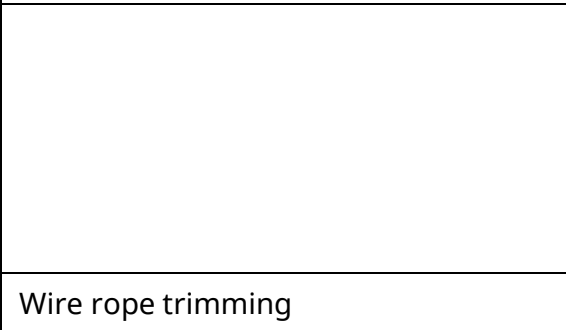
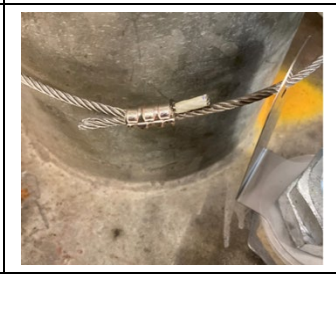
Step No.	Step title	Description	Illustration	Photograph
7.	Mark first thread proud of half	Using a large point permanent marker, mark a line on the first thread fully proud of the half nut.		
8.	Thread-sealant application	Remove half nut from assembly and apply LOXEAL 58-11 thread-sealant. Starting at the line marked in the previous step. Apply a continuous bead of thread-sealant across one full turn off the marked thread. Finishing directly under the start of the applied bead.		

Step No.	Step title	Description	Illustration	Photograph
9.	Replace half nut and loosen quarter turn	Replace the half nut on the assembly until finger tight. Then loosen the half nut one-quarter to one-third of a full turn to allow tear washer to move freely in that position and allow thread-sealant to set.		
10.	Repeat Steps 1 to 9 for the other 2 clamping bolts and ensure the tear washer is well clear of terminal panel access hatchway.			
11.	Wire rope assembly	Feed the wire rope through tear points of the tear washers and hold the ends together.	 <p data-bbox="1243 1273 1500 1305"><i>Wire rope assembly</i></p>	

Step No.	Step title	Description	Illustration	Photograph
12.	Swage installation	<p>Get a swage and pass one end of the wire rope through one hole of the swage and the other end through the second hole of the swage from the opposite direction.</p> <p>During this process, make sure the swage is remote from the terminal panel access hatchway.</p> <p>Adjust the wire rope overlap to ensure that the spacing between the wire rope and the pole is 20 mm all the way around the pole. The tear washer may be bent to ensure 20 mm wire spacing; however, the tear washers are not to be in contact with the pole.</p>	 <p>20mm</p> <p>2</p> <p>Terminal panel access hatchway. Refer Note 3</p> <p>1</p> <p>3</p> <p>4</p> <p>5 x2</p>	
			<i>Swage installation</i>	

Step No.	Step title	Description	Illustration	Photograph
13.	Swage crimping	Place the swage into the pliers' jaws <b>vertically aligned and never horizontally.</b>		
		Select the correct crimping cap marked "4" or "5/32" to match the 4 mm wire rope diameter.	<p style="text-align: center;"><i>Swage crimping sequence</i></p>	
		With the swage in the proper position and holding the overlapping wire rope with a spring clamp, make the first crimp by squeezing the swage pliers handles together until the jaws are completely closed.	<p style="text-align: center;"><i>Correct crimping cap</i></p>	
			<p style="text-align: center;"><i>Swage crimping sequence</i></p>	

Step No.	Step title	Description	Illustration	Photograph
		Swage needs to be crimped 3 times evenly spaced.		
			<i>Swage crimping sequence</i>	
				
			<i>Swage crimping sequence 1 at the centre</i>	
				
			<i>Swage crimping sequence 2 at the outer</i>	
				
			<i>Swage crimping sequence 3 at the opposite outer</i>	

Step No.	Step title	Description	Illustration	Photograph
14	Wire rope trimming	Trim the excess wire rope 10–20 mm way from the edge of the swage by using the wire rope cutter from one end only as required. Use appropriate wire rope cutter to trim: <b>do not use bolt cutter.</b>	 <p>Wire rope trimming</p>	

## **6 Site clean-up**

After completing the installation of slip base pole clamping bolt tethering system, clean up the site and make sure that no scrap materials or tools are left behind and leave the assembly area as safe and tidy as reasonably practicable.

