

**Manual**

**Traffic and Road Use Management  
Volume 4 – Intelligent Transport Systems and Electrical Technology**

**Part 5: Configuration and placement of traffic sensors**

**March 2025**



## Copyright

© The State of Queensland (Department of Transport and Main Roads) 2025.

## Licence



This work is licensed by the State of Queensland (Department of Transport and Main Roads) under a Creative Commons Attribution (CC BY) 4.0 International licence.

## CC BY licence summary statement

In essence, you are free to copy, communicate and adapt this work, as long as you attribute the work to the State of Queensland (Department of Transport and Main Roads). To view a copy of this licence, visit: <https://creativecommons.org/licenses/by/4.0/>

## Translating and interpreting assistance



The Queensland Government is committed to providing accessible services to Queenslanders from all cultural and linguistic backgrounds. If you have difficulty understanding this publication and need a translator, please call the Translating and Interpreting Service (TIS National) on 13 14 50 and ask them to telephone the Queensland Department of Transport and Main Roads on 13 74 68.

## Disclaimer

While every care has been taken in preparing this publication, the State of Queensland accepts no responsibility for decisions or actions taken as a result of any data, information, statement or advice, expressed or implied, contained within. To the best of our knowledge, the content was correct at the time of publishing.

## Feedback

Please send your feedback regarding this document to: [tmr.techdocs@tmr.qld.gov.au](mailto:tmr.techdocs@tmr.qld.gov.au)

# Contents

- 1 Introduction ..... 1**
- 2 Scope ..... 1**
  - 2.1 Vehicle detectors ..... 1
  - 2.2 Traffic counter / classifier ..... 2
  - 2.3 Weigh-in-motion ..... 2
  - 2.4 Active transport counter / classifier ..... 2
- 3 Definition of terms ..... 2**
- 4 Reference documents ..... 3**
- 5 Technology options ..... 4**
- 6 Placement and installation of vehicle detection loops ..... 5**
  - 6.1 Sensor placement for vehicle detection site ..... 5
    - 6.1.1 *Sensors at a signalised intersection* ..... 5
    - 6.1.2 *Motorway detection sensors* ..... 7
  - 6.2 Sensor installation for vehicle detection site ..... 12
    - 6.2.1 *Numbering of sensors* ..... 12
    - 6.2.2 *Inductive loop installation* ..... 12
- 7 Placement and installation of traffic counter / classifier ..... 16**
  - 7.1 Site selection ..... 16
  - 7.2 Applicable standard drawings ..... 16
  - 7.3 Sensor placement at traffic counter / vehicle classifier site ..... 17
    - 7.3.1 *Temporary traffic counter / vehicle classifier sensors* ..... 17
    - 7.3.2 *Permanent traffic counter / vehicle classifier sensors* ..... 20
  - 7.4 Sensor installation for traffic counter / vehicle classifier site ..... 23
    - 7.4.1 *Numbering of sensors* ..... 23
    - 7.4.2 *Pneumatic tube installation* ..... 25
    - 7.4.3 *Inductive loop installation* ..... 27
    - 7.4.4 *Piezoelectric sensor installation* ..... 28
- 8 Placement and installation of high-speed weigh-in-motion sensors ..... 35**
  - 8.1 Site selection ..... 35
    - 8.1.1 *Horizontal curvature* ..... 36
    - 8.1.2 *Longitudinal gradient* ..... 36
    - 8.1.3 *Cross carriageway gradient* ..... 36
    - 8.1.4 *Lane width and line markings* ..... 36
    - 8.1.5 *Surface evenness* ..... 36
    - 8.1.6 *Lane discipline* ..... 37
    - 8.1.7 *Free flowing traffic* ..... 37
    - 8.1.8 *Free of flooding* ..... 37
  - 8.2 Applicable standard drawings ..... 37
  - 8.3 Sensor placement at high-speed weigh-in-motion site ..... 37
    - 8.3.1 *Piezo-Loop-Piezo weigh-in-motion* ..... 37
    - 8.3.2 *Piezo-Piezo-Loop- Piezo-Piezo weigh-in-motion* ..... 38
    - 8.3.3 *Piezo-Piezo weigh-in-motion* ..... 39
    - 8.3.4 *Strain gauge weigh-in-motion* ..... 39
  - 8.4 Sensor Installation at high-speed weigh-in-motion site ..... 40
    - 8.4.1 *Numbering of sensors* ..... 40

8.4.2	<i>Inductive loop installation</i>	41
8.4.3	<i>Piezoelectric sensor installation</i>	41
8.4.4	<i>Strain gauge installation</i>	41
<b>9</b>	<b>Placement and installation of active transport sensors</b>	<b>41</b>
9.1	Site selection	42
9.2	Applicable standard drawings	43
9.3	Sensor placement at active transport site	43
9.3.1	<i>Bicycle counter</i>	43
9.3.2	<i>Collocated bicycle and pedestrian counter</i>	44
9.3.3	<i>Active transport classifier</i>	45
9.4	Sensor installation for active transport counter/classifier (ATCC) site	55
9.4.1	<i>Numbering of sensors</i>	55
9.4.2	<i>Pneumatic tube installation</i>	55
9.4.3	<i>Piezoelectric sensor installation</i>	55
9.4.4	<i>Passive infrared sensor installation</i>	55
9.4.5	<i>Video analytics camera installation</i>	56

## 1 Introduction

This document sets out the practices used by the Department of Transport and Main Roads on the selection, configuration, placement, and installation of traffic sensors for traffic management, traffic surveys and vehicle identification. The list of traffic sensors covered in this document include:

- vehicle detectors as defined in MRTS204 *Vehicle Detectors*
- traffic counters and classifiers as defined in MRTS251 *Traffic Counter / Classifier*
- weigh-in-motion sensors as defined in MRTS203 *Provision of Weigh-in-Motion System*, and
- active transport counters and classifiers as defined in MRTS215 *Active Transport Counter / Classifier (ATCC)*.

Details of vehicle detector, classifier and weigh-in-motion (WiM) sensor selection, placement and installation given in this document are the normal practice used by the department; however, the exact placement may be modified to suit an installation specific to sites, in which case, the reader should consult with the Principal.

The Principal can be the District's project representative, the department's Engineering and Technology Branch, or both.

## 2 Scope

The scope of traffic sensors covered in this document are for the following applications.

### 2.1 Vehicle detectors

Vehicle detectors are used to measure vehicle flow, occupancy, headways, speed and length. A vehicle detection site is to consist of a STREAMS-supported vehicle detector and associated sensors that are capable of accurately measuring these parameters. One-minute data is used by the following STREAMS applications:

- ramp signalling
- incident detection
- traffic signal control
- coordination plan selection
- travel time data
- Variable Speed Limit (VSL), and/or
- Vehicle Activated Signs (VAS)

## 2.2 Traffic counter / classifier

A traffic counter is used to automatically collect traffic volume counts of motorised vehicles. A classifier is a traffic counter which is capable of classifying the counting targets by types.

A vehicle classification site consists of a vehicle classifier and associated sensor arrays. The site can classify a vehicle either by axle configuration in accordance with the Austroads vehicle classification scheme, or by vehicle length per the department's length classification scheme.

Data collected by traffic counter / classifier reside locally within the device, until the device is interrogated to transfer data to a departmental database.

## 2.3 Weigh-in-motion

A high-speed WiM site consists of a WiM logger and associated sensor arrays. The site can weigh the dynamic weights of individual axles of a vehicle, while the vehicle is moving at normal travelling speeds.

## 2.4 Active transport counter / classifier

An active transport counter is used to automatically collect traffic volume counts of active transport participants. Counter can be dedicated for specific types of active transport events, for example, bicycle or pedestrian.

An active transport classifier is a counting device capable of distinguishing different counting targets, these include bicycle, scooter, and pedestrian recognition in a common detection zone. The classifier also reports the volume of undetermined events.

Data collected by active an transport counter / classifier reside locally within the device, until the device is interrogated to transfer data to a departmental database.

## 3 Definition of terms

**Table 3 – Definition of terms**

Term	Definition
Active transport	Active transport relates to physical activity undertaken as a means of transport. In the context of this document, it refers to movement activity undertaken on a cycling track and footpath.
AI	Artificial Intelligence.
ATCC	Active Transport Counter / Classifier.
Classifier	A counting device that can distinguish detected objects between pre-defined types.
Counter	A counter will count and record vehicle traffic-volume and specific types of road users, such as pedestrians and cyclists.
OGA	Open Grade Asphalt.
PIR sensor	A passive infrared (PIR) sensor is an electronic sensor that detects infrared light radiating from objects in its field of view.
Sensor	A device that perceives the vehicle and produces raw signals. In some cases, this sensor may be an integrated part of a detector and not a separate item.

Term	Definition
Separated path	A path which is divided into separate sections, one of which is designated for the exclusive use of cyclists and the other for the exclusive use of pedestrians.
Shared path	A path where pedestrians and cyclists share the same path space.
STREAMS	A departmental traffic management system.
Vehicle detector	A device that processes the raw vehicle detection signal received from the sensors. The processed data is in a readable form.
Vehicle detector site	A location on the road network where vehicle data collection is taking place.
Video Analytics (VA)	In the context of this document, VA refers to the automated analysis of video feeds using Computer Vision to classify transportation modes such as bicycles, pedestrians, scooters, and other objects of interest.
WiM	Weigh-in-motion.
WiM logger	A weigh-in-motion logger used for capturing the weights and individual axles of vehicles while in motion.

#### 4 Reference documents

**Table 4 – References**

Reference	Title
AGRD06A-17	<i>Austrroads Guide to Road Design Part 6A: Paths for Walking and Cycling</i>
AGTM03-20	<i>Austrroads Guide to Traffic Management Part 3: Traffic Studies and Analysis Methods</i>
AS/NZS 2276.2	<i>Cables for traffic signal installations, Part 2 Feeder cable for vehicle detectors</i>
AS/NZS 2276.3	<i>Cables for traffic signal installations, Part 3 Loop cable for vehicle detectors</i>
DDPSM	<a href="#">Drafting and Design Presentation Standards Manual</a>
ITS Placement Guideline	<a href="#">ITS Placement Guideline</a> – Motorways Detectors, VSL / LCS, VMS and Weather Stations
MRTS30	<i>Asphalt Pavements</i>
MRTS93	<i>Traffic Signals</i>
MRTS203	<i>Provision of Weigh-In-Motion Systems</i>
MRTS204	<i>Vehicle Detectors</i>
MRTS215	<i>Active Transport Counter / Classifier (ATCC)</i>
MRTS251	<i>Traffic Counter / Classifier</i>
QGTM	<a href="#">Queensland Guide to Traffic Management (QGTM)</a>
QGSM	<a href="#">Queensland Guide to Smart Motorways (QGSM)</a>
RoadTek SMS S001	<i>Respirable crystalline silica control standard</i>
RoadTek	<i>Procedure - Selection and use of respiratory protection</i>
SD1363	<i>Traffic Sign – Multiple Traffic Sign Support</i>
SD1368	<i>Traffic Sign – Single Traffic Sign Support</i>
SD1372	<i>Road Lighting – Slip Base Pole</i>

Reference	Title
SD1424	<i>Traffic Signals – Detector loops installation details asphalt pavement</i>
SD1425	<i>Traffic Signals – Detector loops placement details</i>
SD1426	<i>Traffic Signals – Detector loops standard configurations</i>
SD1701	<i>Traffic Signals – Detector loops counting / right-turn loops and diode connection details</i>
SD1702	<i>Traffic Signals – Detector loops motorways management placement details</i>
SD1906	<i>ITS – WiM piezo sensor installation details</i>
SD1908	<i>ITS – WiM sensor configuration Piezo-Loop-Piezo</i>
SD1909	<i>ITS – WiM sensor configuration Piezo-Piezo-Loop-Piezo-Piezo</i>
SD1910	<i>ITS – WiM sensor configuration Piezo-Piezo</i>
SD1911	<i>ITS – WiM sensor configuration Strain Sensor</i>
SD1916	<i>ITS – Axle-based vehicle classifier sensor installation details</i>
SD1917	<i>ITS – Axle-based vehicle classifier sensor configuration Loop-Piezo-Loop</i>
SD1918	<i>ITS – Axle-based vehicle classifier sensor configuration Piezo-Loop-Piezo</i>
SD1919	<i>ITS – Axle-based vehicle classifier sensor configuration Piezo-Piezo</i>
SD1920	<i>ITS – Length based vehicle classifier sensor configuration Loop-Loop</i>
SD1921	<i>ITS – Axle-based vehicle classifier sensor configuration Tube-Tube</i>
SD1922	<i>ITS – Vehicle classifier cabinet details Solar Powered</i>
SD1923	<i>ITS – Vehicle classifier cabinet details Mains Powered</i>
SD1924	<i>ITS – Vehicle classifier cabinet installation Solar Powered</i>
SD1925	<i>ITS – Vehicle classifier cabinet installation Mains Powered</i>
SD1928	<i>ITS – Bicycle counter</i>
SD1929	<i>ITS – Bicycle and pedestrian counter</i>
TMR WHS P031	<i>Managing exposure to silica procedure</i>
WSQ	<i>WorkSafe Queensland - Code of practice – Managing respirable crystalline silica dust exposure in manufacturing of construction elements</i>

## 5 Technology options

Various technologies support the traffic sensor function of vehicle detection, classification and WiM. Table 5 lists the sensors used in this document.

**Table 5 – Sensor technologies**

Sensor technology	Application
Inductive loops	Vehicle detection, counter / classifier, WiM.
Passive infrared (PIR) sensor	Pedestrian counter.
Piezoelectric sensors	Vehicle counter, bicycle counter, vehicle classifier, WiM.
Pneumatic tubes	Temporary installations for vehicle detection, counter / classifier.
Strain gauges	WiM.
Video analytics camera	Active transport classifier.

Irrespective of the sensor technology, detection accuracy depends on sensitivity of the sensors, sensor placement, and sensor array configuration.

This document discusses the placement and installation of inductive loops, piezoelectric sensors, pneumatic tubes, PIR sensors, video analytics cameras and strain gauges, for the construction of vehicle detection site, traffic counting site, vehicle classification site, WiM site, and active transport site.

## **6 Placement and installation of vehicle detection loops**

### **6.1 Sensor placement for vehicle detection site**

The placement of a sensor depends upon its intended use and pavement type / characteristics.

Unless otherwise specified, sensors used for vehicle detection and/or identification, must be able to measure traffic volume (counting), occupancy, speed, headway and length.

#### **6.1.1 Sensors at a signalised intersection**

Sensors at a signalised intersection can be used for traffic signal control, traffic management, for traffic survey data, or for traffic violation detection. Except for red-light camera application, a separate sensor is to be allocated for each traffic lane at signalised intersections. Where a single detector is connected to multiple traffic loops, refer to SD1426 *Traffic Signals - Detector loops standard configurations* for details on how the loops are connected in the pit.

Sensors used in traffic signal control and management can be:

- a) stop-line or right-turn sensors at intersections
- b) slip lane sensors
- c) advance or queue sensors
- d) sensors at mid-block or school pedestrian crossings, and
- e) departure loops.

##### **6.1.1.1 Sensor selection**

Unless otherwise specified, sensors that are used to operate the traffic signal controller, as a minimum, are to measure traffic volume, headway and occupancy. This only applies to the following:

- Stop-line sensors
- Right-turn sensors
- slip lane sensors
- advance detection sensors.

##### **6.1.1.2 Stop-line sensors**

Stop-line sensors are to be located upstream of the stop-line at a signalised intersection, as shown on SD1425 *Traffic Signals - Detector loops placement details*.

##### **6.1.1.3 Right-turn sensors**

For the detection of right-turn vehicles, one or more sensors connected in series are to be used. Details on the placement of sensors are shown on SD1425. If required, additional sensors, are to be placed 1 m downstream from the last sensor and downstream from the stop-line.

#### **6.1.1.4 Right-turn sensor configuration**

To obtain accurate performance measures for the right-turn movement, it is highly recommended that the first sensor upstream of the stop bar be connected to a separate vehicle detector to the other sensors. The controller personality would use the 'detector diode' function to combine the sensors internally to control demand for the right-turn movement. Refer to SD1701 *Traffic Signals – Detector loops counting / right turn loops and diode connection details*.

For installations where there are spare detector sensor inputs in the controller, all sensors may be separated into individual detectors and the 'detector diode' function in the personality may be used to combine these sensors internally to control demand for the right-turn movement. This allows the individual sensors to be monitored and faults to be promptly detected.

Combined red-light and speed camera loops can be installed at the same approach.

Where there is a conflict between the placement of combined red-light and speed camera loops and traffic signal loops, the latter shall take preference.

#### **6.1.1.5 Mid-block crossing sensors**

Vehicle detection sensors used in mid-block (or school) pedestrian crossings are to be placed upstream of the stop-line as shown on SD1425.

#### **6.1.1.6 Advance detection sensors**

Advance detection sensors are strategically located upstream of the stop-line well in advance to measure headways (the time period between successive sensor actuations), or gap time, to terminate the traffic signal phase earlier under free flow conditions.

Advance detection sensors are to be used when approach speed is high or when there is a large proportion of heavy vehicles. They are to be located to suit the required stopping distance for the 85<sup>th</sup> percentile approach speed, at 35 metres (for 50 km/h speed limit) to 40 metres (60 km/h) upstream of the stop-line.

#### **6.1.1.7 Mid-block measurement sensors**

Mid-block measurement sensors are installed to measure traffic flow characteristics between intersections. These sensors are to be located between one third and halfway from the depart side of one intersection to the stop-line of the next downstream intersection.

#### **6.1.1.8 Depart-side sensors**

In the absence of mid-block measurement sensors, depart-side sensors are installed to determine turning volumes of shared lanes and to detect downstream link congestion. These sensors are to be located downstream of the stop-line, past the shared centre area of an intersection.

#### **6.1.1.9 Red-light camera sensors**

Traffic violation sensors are installed in conjunction with a red-light camera and flash unit, to enable red-light traffic violations to be detected and photographed. Sensors are installed in exclusive through-lanes and shared lanes where there is no left or right-turn green arrow displayed in conjunction with the full red signal.

Loops constructed for enforcement purposes must not impede normal operation of traffic signals by relocating traffic signal loops to undesirable locations. Where there is a conflict between the placement of combined red-light and speed camera loops and traffic signal loops, the latter shall take precedence.

#### **6.1.1.9.1 Red-light camera sensor placement and configuration**

Red-light camera (traffic violation) installations shall use inductive loops. The placement and configuration of these loops are as shown on both *SD1425 Traffic Signals - Detector loops placement details* and *SD1702 Traffic Signals - Detector loops motorways management placement details*.

Red-light camera loops shall be:

- a) installed with edges parallel to both the stop-line and approach / departure kerb, where the stop-line is not perpendicular to the kerb, the shape of the loop shall be a parallelogram, and
- b) installed so that no part of the loop shall be any closer than 1.2 m to the trajectory of cross or turning traffic of another phase. This will prevent false actuations.

For intersections that are connected to STREAMS, it is recommended that detector 16 be connected to the camera unit so that camera alarms, such as no film, camera faults, and so on, can be reported to STREAMS. Therefore, detector 16 should not be used as a normal detector when a red-light camera is installed at such an intersection. Note that controller software version 2.4 or later allows for the status of up to 24 vehicle detectors to be returned to STREAMS, so detector 24 may be used for this purpose where this software is installed.

#### **6.1.1.10 Bicycle sensors**

Bicycle sensors are to be installed within bicycle lanes / paths only. These sensors are to be placed upstream of the stop-line. Where inductive loop is used for detecting bicycles, the centre of the loop is to be marked longitudinally with 5 diamonds 100 mm x 100 mm at 300 mm centres) as shown on SD1425.

#### **6.1.2 Motorway detection sensors**

Motorway detection sensors refer to sensors located either on the motorway, entry-ramps or exit-ramps. These vehicle detection sensors are used to increase the safety and performance of the road network through incident detection and management, ramp signalling and determining traveller information. For additional information, refer to *SD1702 Traffic Signals - Detector loops motorways management placement details*.

##### **6.1.2.1 On motorways**

Vehicle detection sensors on motorways are to be located as follows:

1. immediately upstream from an entry-ramp nose
2. immediately downstream from an exit-ramp nose, and
3. at 500 m maximum spacing.

Note: By 'nose' the hard gore is meant.

Designers should refer to *Queensland Guide to Smart Motorways (QGSM)*.

### 6.1.2.2 Ramp signalling

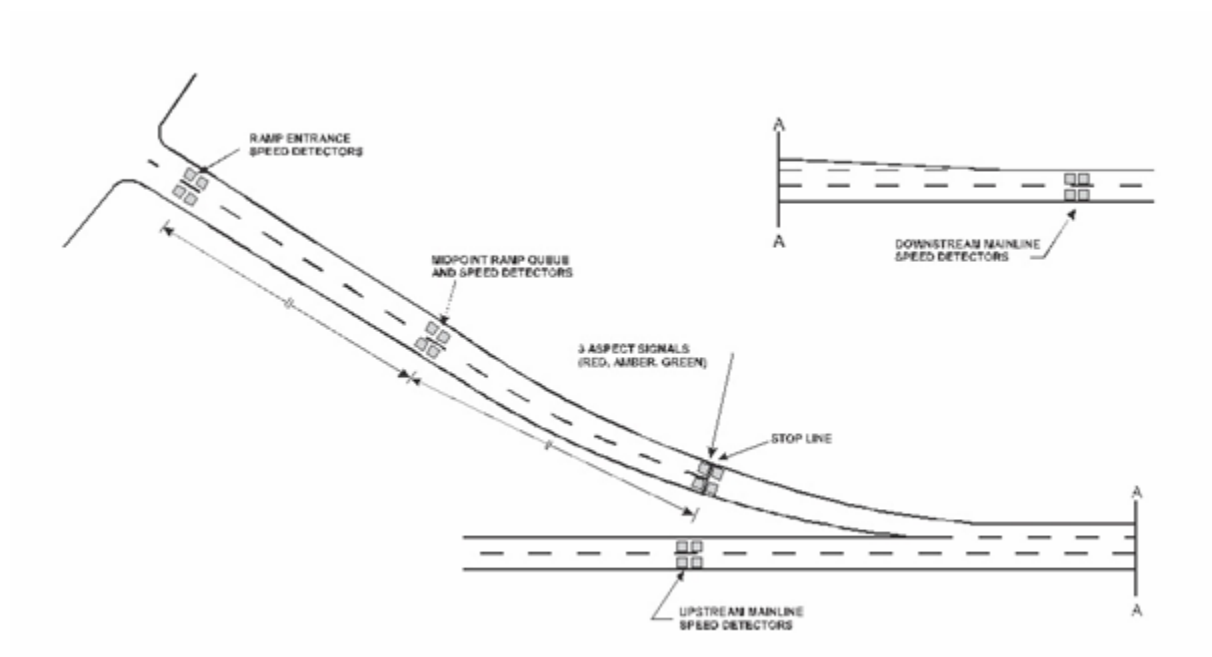
The department's ramp signalling model is based on ramp signalling algorithms.

There are 4 different types of entry-ramps supported by this model as described below:

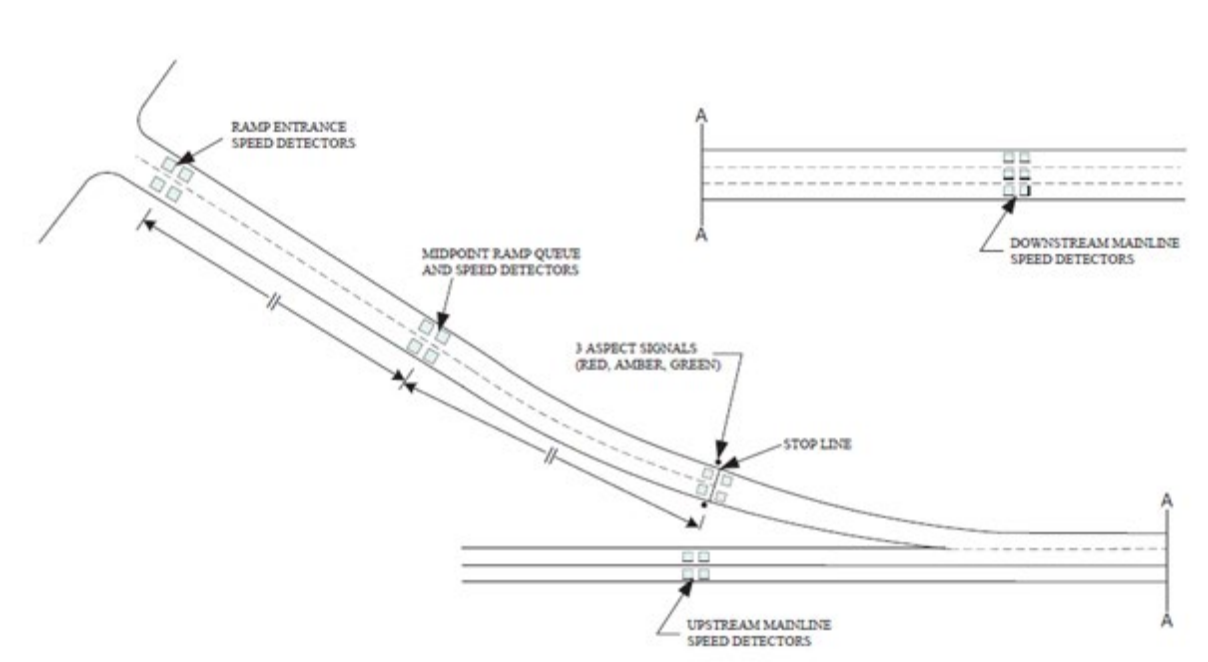
- Simple entry-ramp types
  - this type of entry-ramp involves a simple ramp of one or more general traffic lanes where the stop bar extends across ALL lanes of the entry-ramp, and
- Complex entry-ramp types
  - two lanes of metered traffic, plus a priority lane
  - two lanes of metered traffic, plus a metered priority lane, and
  - motorway to motorway entry-ramps.

Designers must consult with the department's Active Network Operations unit when placing sensors for complex ramp signalling. Refer to [QGTM](#) Part 9 Section 8 for further details. The ramp signalling algorithms require vehicle detection sensors to be placed at various locations to optimise motorway flow. The required locations are described in Figures 6.1.2.2(a) to 6.1.2.2(d), and Section 6.1.2.2.1.

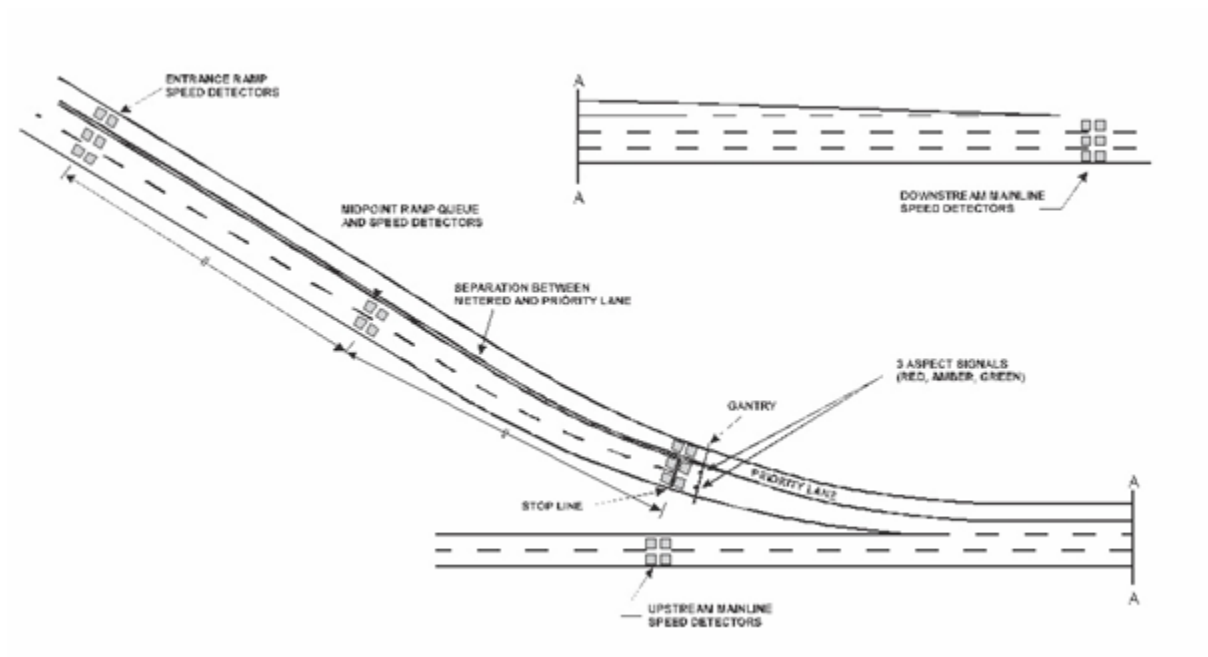
**Figure 6.1.2.2(a) – Simple entry-ramp, 2 lanes of metered traffic**

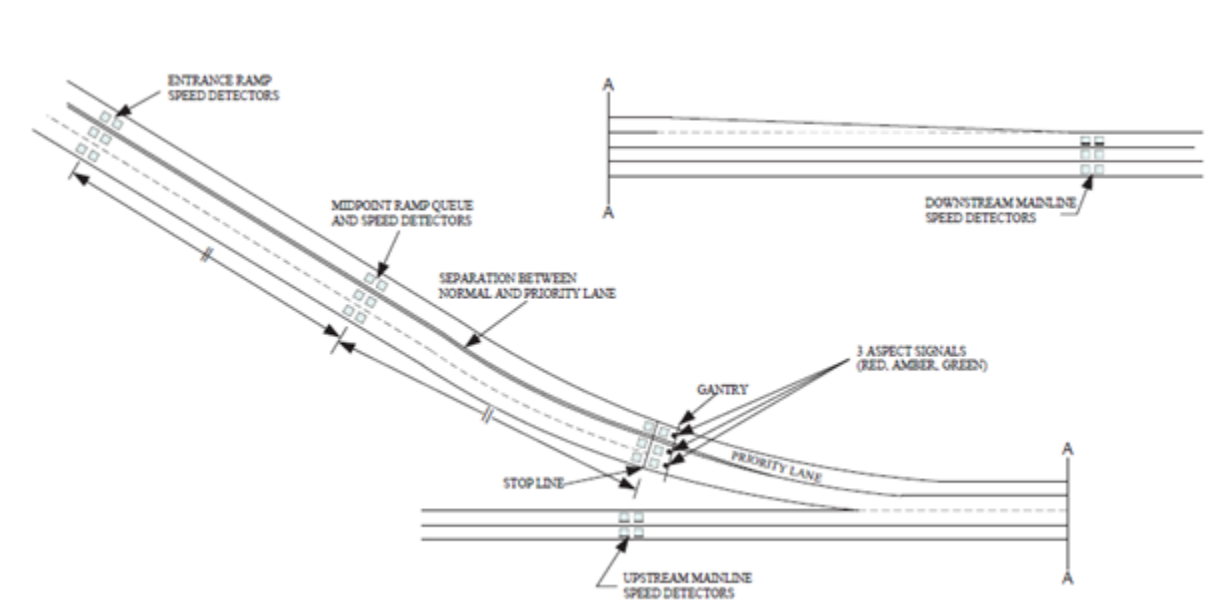


**Figure 6.1.2.2(b) – Simple entry-ramp, 2 lanes of metered traffic and an added lane**



**Figure 6.1.2.2(c) – Complex entry-ramp, 2 lanes of metered traffic and a priority lane**



**Figure 6.1.2.2(d) – Complex entry-ramp, 2 lanes of metered traffic and a metered priority lane**

#### 6.1.2.2.1 Sensor placement and configuration

Unless otherwise specified, all sensors used for the purpose of ramp signalling, shall permit measurement of traffic volume (counting), speed, headway, occupancy and vehicle length.

##### Main line sensors

The sensors on the mainline provide the data required for the ramp signalling algorithms to ensure the ramps are metered appropriately to optimise the motorway flow. These sensors are to be placed outside the merging area as follows:

- upstream mainline sensors are to be placed before the ramp nose, and
- downstream mainline sensors are to be placed at the end of the final merge taper, or
- downstream mainline sensors are to be placed at minimum of 320 m from the ramp nose for entry-ramps with a single added lane situation without a merge.

The upstream mainline sensors are used for traffic counting and monitoring motorway performance. These sensors can also be used by the ramp signalling algorithm as a backup if the downstream mainline sensors become unavailable for any reason.

These mainline sensors shall form part of the regular array of mainline vehicle sensors.

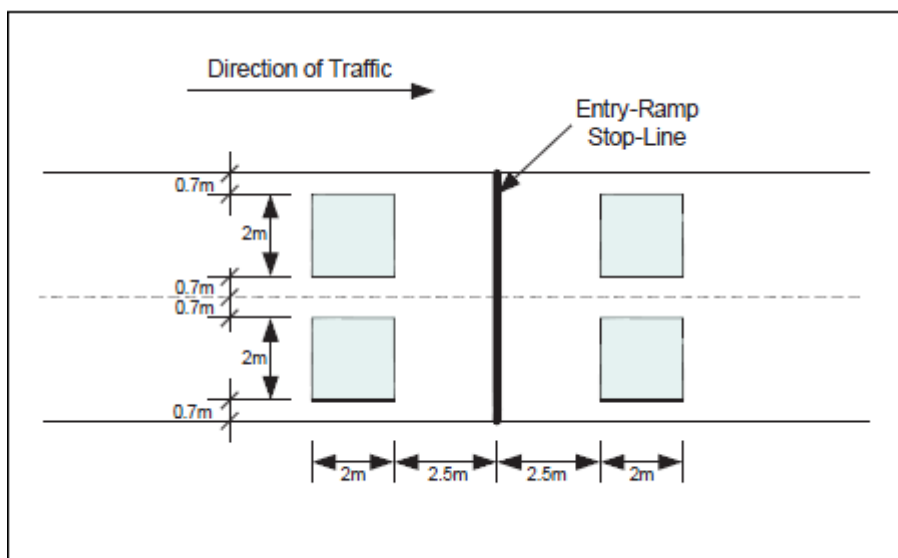
##### Stop line sensors

Sensors are to be placed immediately upstream of the stop-line to enable cycling of the ramp signals when the ramp signalling system is active.

Sensors are also to be placed immediately downstream of the stop-line for vehicle counting associated with the ramp signalling algorithms.

When inductive loops are used as sensors, they are to be placed as follows:

- loop to be placed 2.5 metres (trailing edge of loop) upstream of the stop-line, and
- loop to be placed 2.5 metres (leading edge of loop) downstream of the stop-line.

**Figure 6.1.2.2.1 – Stop-line loop placement details****Ramp queue sensors**

Sensors are to be placed at the ramp entrance and at the midpoint between the stop-line and the start of the ramp for queue length estimates and queue management by the ramp signalling algorithms.

Midpoint sensors are not required for an unmetered priority access lane; however, it is recommended that midpoint sensors be installed on unmetered priority access lanes for future consideration.

Where a ramp is very short relative to the desirable storage, additional sensors may be required to detect queues on the arterial roads leading on to the ramp.

**6.1.2.2.2 Motorway-to-motorway entry-ramps**

Motorway-to-motorway ramps provide connections between high-speed facilities where drivers may not expect to stop, nor expect to encounter a queue of stopped vehicles. Therefore, signalling motorway-to-motorway entry-ramps should be avoided wherever practicable. When this is not possible, adequate storage should be catered for in the geometric design of these ramps. The principles mentioned in Section 6.2.2.1 shall be applied on these ramps for effective ramp signalling.

**6.1.2.2.3 Non-metered entry-ramps**

Where ramp metering is not specified, the entry-ramps must have their flow measured for traffic volume (counting), speed, headway, occupancy and vehicle length. The sensors required to measure these parameters are to be located adjacent to the sensors measuring the mainline motorway flow immediately upstream of the entry-ramp nose.

**6.1.2.2.4 Exit-ramps**

All exit-ramps must have their flow measured for traffic volume (counting), speed, headway, occupancy and vehicle length. The sensors required to measure these parameters are to be located adjacent to the sensors measuring the mainline motorway flow towards the start of the exit-ramp so that queues can be detected and prevented from extending on to the motorway. Typically, these vehicle detection sensors are located at the one-third point along the ramp measured from the gore area. This may be adjusted depending on the situation.

## **6.2 Sensor installation for vehicle detection site**

### **6.2.1 Numbering of sensors**

#### **6.2.1.1 Intersection sensors**

For numbering sensors at an intersection, refer to the [\*Drafting and Design Presentation Standards Manual\*](#) (DDPSM) Volume 2 Chapter 2.

#### **6.2.2 Inductive loop installation**

Vehicle detection loops are to be located as shown on SD1424 *Traffic Signals - Detector loops installation details asphalt pavement* and SD1425 *Traffic Signals - Detector loops placement details*.

Vehicle detection loops installed on the department's road network are to be installed in asphalt or in concrete pavement. Loops installed in bitumen seals are not covered in this document.

When determining the placement of detector loops, the following points should be considered regarding loop installation:

- a) loop wire needs to be close to the road surface for optimum sensitivity: the minimum distance to surface is 15 mm
- b) loops cannot be installed over any bridges, culverts, stormwater drains, or similar structures, unless there is at least 80 mm of covering pavement
- c) loops cannot be installed closer than 300 mm to any ferrous metal object such as a manhole cover, pipe or reinforcing
- d) the distance between the loop and its detector unit, normally located in the controller housing, shall be as specified by the manufacturer
- e) inductive loops on new pavements shall be pre-formed unless otherwise specified by the Principal
- f) loops installed in new pavements shall be pre-formed, and
- g) loops installed in existing pavements may be formed insitu.

The location and/or size of any detector loop may vary to suit special circumstances, such as geometry (for example, driveway, turning lane, parking area), location of expansion joints or ferrous metal objects.

##### **6.2.2.1 Loop installed in asphalt pavement**

For installation in asphalt pavement, the Quadropole loop takes the form of a 'figure 8' as shown on SD1425 *Traffic Signals - Detector loops - placement details*. The following are the requirements of rectangular and Quadropole loops installed in asphalt pavement:

- a) loop cable shall comply with AS/NZS 2276.3 *Cables for traffic signal installations, Part 3 Loop cable for vehicle detectors*
- b) loop feeder cable shall comply with AS/NZS 2276.2 *Cables for traffic signal installations, Part 2 Feeder cable for vehicle detectors*.
- c) loop cable shall be continuous, that is, no joints permitted, between Start (S) and Finish (F).
- d) loop leadings (S and F) to each loop shall be twisted together at approximately 1 turn per 100 mm

- e) loop inductance connected across its input terminals lies within range 100  $\mu\text{H}$  to 700  $\mu\text{H}$  and a Q factor in the range of:
  - i. 5 to 50 below 60 kHz, and
  - ii. 3 to 50 above 60 kHz
- f) loop detector cables and feeder cables shall be jointed in Type 3 pits on the road reserve. Each joint shall be separately insulated and sealed to prevent water ingress
- g) all loop feeders shall be returned to the cable pit in the road reserve (or the median of a minimum 2 m wide) except for right-turn presence loops, or loops in the 2 lanes closest to the median in a 4 or more lane approach, which may be returned to a cable pit in the median if a median post is required
- h) all loop cable ends shall be labelled with Helagrip Markers (HG2 5) or equivalent with Start (S), Finish (F) and numbered as per the design plan
- i) all feeder cables shall be labelled with Helagrip Markers (HG4 9), or equivalent, at each end to show the detector number as per the design plan (for example, 1, 2 and so on)
- j) retaining wedges must be fitted at 300 to 400 mm spacing to ensure loop cable does not move while sealant is applied. The wedge material shall be flexible and water resistant
- k) the loop shall be sealed in the slots using a polyurethane slot sealant or equivalent
- l) the number of turns for loops shall be: Rectangular / Square (4 turns) and Quadrupole (3 turns). Motorway preformed loops have 5 turns, and
- m) for a combined detector cable and feeder cable lengths in excess of manufacturer specified limits, a 1% variation check is required to determine if another loop turn or a signal amplifier is needed.

#### **6.2.2.2 Loop installed in concrete pavement**

For installation in concrete pavement, the loop is recommended to be pre-formed and takes the form of a square as shown on SD1424 *Traffic Signals - Detector loops installation details asphalt pavement*. The following are the requirements of pre-formed square loops installed in concrete pavement:

1. loops shall be pre-formed, square, measuring 2 m by 2 m, supplied with 5 turns (acceptable inductance range: 100  $\mu\text{H}$  700  $\mu\text{H}$ )
2. pre-formed loops shall be assembled, joined and tested prior to delivery at site. The loops shall be supplied complete with factory assembled lead in cables. Cores shall be continuous: jointing of cores is unacceptable
3. the individual loop cores shall be insulated individually and encapsulated within a flexible sleeve constructed from polypropylene, polyethylene, XLPE or other suitable material
4. lead-in cable shall be a continuation of the loop cables. They shall be insulated individually, twisted together at approximately 4 turns per 100 mm and encapsulated within a flexible sleeve
5. detector loops shall be installed and sealed into slots cut into the top of a concrete sub-base

6. slots for the pre-formed loops shall be cut using conventional loop cutting or milling type equipment. Under no circumstances shall percussion type equipment be used to form the slots. The loop shall be sealed in the slots using an approved slot sealant
7. all loop feeders shall be returned to the cable pit in the footpath (or the median with a minimum width of 2 m). Length of lead-ins shall be kept to the minimum to extend 0.6 m to 1 m past the top of the pit. Loops in the 2 lanes closest to the median in a 4 or more lane approach may be returned to a cable pit in the median
8. loop detector cables and feeder cables shall be jointed in pits. Each joint shall be separately insulated and sealed to prevent water ingress, and
9. loops in asphalt pavement are to be installed in accordance with MRTS93 *Traffic Signals* in dense grade with open grade cover.

### 6.2.2.3 Loop cabling standards

The loop cable shall comply with AS/NZS 2276.3 *Cables for traffic signal installations, Part 3 Loop cable for vehicle detectors*.

The loop feeder cable shall comply with AS/NZS 2276.2 *Cables for traffic signal installations, Part 2 Feeder cable for vehicle detectors*.

All loops and feeder cables used must be preapproved by the department.

### 6.2.2.4 Loop feeder cable

The loop lead-in is the cable between the loop and its nearest pit. The loop feeder cable connects the lead in cable in the pit to the controller. The total length of the cables from the loop to the controller affects the detector sensitivity and should be kept to the minimum and, in any case, within the limits specified by the manufacturer.

### 6.2.2.5 Loop configuration

**Table 6.2.2.5 – Transport and Main Roads' vehicle detector loop configuration**

Application	Shape	Length <sup>1</sup>	Turns	Remarks
Stop line	Rectangular	2 m	3	Departing edge of loop is 4 m from the stop line
Right turn	Rectangular	1.2 m and 2 m	3	3 or more loops in series spaced at 1.5 m upstream from the stop line and/or at 1 m spacings downstream of the stop line
Mid-block ped crossing	Rectangular	2 m	3	
Mid-block measurement	Rectangular	2 m	4	
Advance	Rectangular	2 m	3	35-40 m in advance of the stop line
Speed <sup>2</sup>	2 x Rectangular	2 m	4 <sup>3</sup>	
Motorway	Rectangular	2 m	4 <sup>3</sup>	Same as speed loops; 4 turns, or 5 turns, if pre-formed

Application	Shape	Length <sup>1</sup>	Turns	Remarks
Motorway ramp	2 x Rectangular	2 m	4 <sup>3</sup>	Same as speed loops; 4 turns, or 5 turns, if pre-formed
Red light camera	Rectangular / Skew	0.7 m	Leading 4 turns Trailing 3 turns	Two groups; at the stop line and 2.5 m behind and parallel to the stop line
Bicycle	Rectangular	1.2 m	3 turns	The centre of the loop is to be marked longitudinally with five diamonds (100 mm x 100 mm at 300 mm centres)

Notes:

<sup>1</sup> Unless specified, width of loop varies with width of traffic lane.

- For Traffic Signals, refer to SD1425, and
- For Motorways, refer to SD1702

<sup>2</sup> Two loops required. Distance between leading edges is 7 m. Where a spacing of exactly 7 m between leading edges is not possible due to pavement constraints, spacing may be increased in 0.1 m increments to a maximum of 8.5 m.

<sup>3</sup> 5 turns if pre-formed.

#### 6.2.2.5.1 Shape of loop

The requirement to detect all types of vehicles from bicycles and motorcycles to high bed trailer trucks, while avoiding detection of vehicles in adjacent lanes, has led to a variety of loop designs. Detector loop designs used by the department are Rectangular and Quadrupole as shown in SD1424 *Traffic Signals – Detector loops installation details asphalt pavement* and SD1425 *Traffic Signals – Detector loops placement details*.

For speed measurement two identical rectangular loops are used. Refer to SD1702 *Traffic Signals – Detector loops motorways management placement details* for details on the distance between leading edges of loops.

#### 6.2.2.5.2 Sizes of loop

Loop sizes determine the detection zone of the loop.

Loop length depends on the dimension of the target vehicle and expected vehicle speed. Loop lengths used by the department vary from 0.7 m to 2.0 m. In some situations, multiple loops are used in series to give an effective loop length much longer than this. Refer to Table 6.2.2.5 for details of permitted configurations.

Loop width depends on the dimension of the target vehicles to be detected and on the width of the traffic lane. Unless specified otherwise, width of loop varies with the width of the traffic lane. Refer to Note (1) on Table 6.2.2.5 for details.

#### 6.2.2.5.3 Number of turns

The number of turns of the conductor making up the loop determines the loop inductance and sensitivity. All loops should have suitable number of turns to provide a nominal minimum inductance of between 100 to 700  $\mu\text{H}$ .

## 7 Placement and installation of traffic counter / classifier

Traffic counter / classifier in this section refers to the device used for counting / classifying motor vehicles. Traffic counter which performs traffic counting in active transport is discussed in Section 9.

### 7.1 Site selection

The general considerations when choosing a suitable site location are:

- safety
- visibility
- geometry, such as horizontal curvatures, vertical curvatures, longitudinal grade, and lane width
- risk of flooding
- security
- comfort
- cabinet location, and
- pavement condition.

In addition, the site and pavement characteristics in the vicinity of the sensors influence road users' behaviour and, hence, can affect the quality of data. It is important when selecting a site location that these considerations are thoroughly assessed as they will compromise data quality.

Although it may not always be possible to satisfy all the preferable site features, designers shall demonstrate that all effort has been made to minimise the risk of data inaccuracy and inconsistency resulting from unfavourable site locations and characteristics.

Listed following are the characteristics that a site should avoid:

- sites that have bad lane discipline and excessive lane changing
- sites where vehicles will not cross perpendicularly to the piezo or tube sensors
- sites where vehicles accelerate or decelerate due to geometry, traffic signals, or intersections
- sites where vehicles stop or park on / over sensors of the site, and/or
- sites where vehicles will turn

### 7.2 Applicable standard drawings

Sensor placement and installation at all traffic counter / vehicle classification sites shall be in accordance with the sections following as well as the details in the following Standard Drawings:

- SD1916 ITS – *Axle-based vehicle classifier sensor installation details*
- SD1917 ITS – *Axle-based vehicle classifier sensor configuration Loop-Piezo-Loop*
- SD1918 ITS – *Axle-based vehicle classifier sensor configuration Piezo-Loop-Piezo*
- SD1919 ITS – *Axle-based vehicle classifier sensor configuration Piezo-Piezo*

- SD1920 ITS – *Length based vehicle classifier sensor configuration Loop-Loop*, and
- SD1921 ITS – *Axle-based vehicle classifier sensor configuration Tube-Tube*

### **7.3 Sensor placement at traffic counter / vehicle classifier site**

Traffic counter / vehicle classifier sites use a combination of sensing technologies, including inductive loop, piezoelectric device, and pneumatic tube.

Traffic counter / classifier sites are used for capturing traffic information such as volume counts and vehicle classification for traffic survey and planning purposes.

Traffic counter / vehicle classifier site can be:

- a) temporary installation, or
- b) permanent site.

#### **7.3.1 Temporary traffic counter / vehicle classifier sensors**

Temporary Sites support short term traffic survey and, therefore, the installation requires short turnaround time and, in many instances, also requires flexibility in terms of site selection. In temporary sites, loggers are installed when needed and recovered after the survey period concludes, whereas sensors can be either permanently set in the pavement or temporarily installed for the period of traffic survey.

Where permanent sensors are used in a temporary site, the sensors shall be as per the details in Section 7.3.2.

Where temporary sensors are used in a temporary site, these are typically pneumatic tubes which can be installed in different ways to suit number of lanes, direction of traffic flow and traffic volume. Two types of sites are considered, namely:

- single carriageway bi-directional sites, and
- single carriageway uni-directional sites.

All tube classifier installations shall be able to measure individual vehicles' travelling speed, to classify vehicles by Austroads 94 scheme defined in *Austroads Guide to Traffic Management Part 3: Traffic Studies and Analysis Methods*, and to report traffic volume by vehicle class and by speed. To do this, all tube installations shall consist of 2 pneumatic tube sensors perpendicular to the running lane and in parallel to each other exactly one or 2 metres apart, depending on the type of logger being used. Refer to SD1921 *Intelligent Transport System – Axle-based vehicle classifier sensor configuration Tube-Tube* for details.

The normal use of pneumatic tubes is to provide a roadside logger with the exact timing of axle events. These axle events are downloaded from the logger and converted to classification, direction and speed of each vehicle event, and traffic summary parameters: for example, volume by vehicle types.

The accuracy, in terms of vehicle classification and traffic parameters, of a site using pneumatic tubes is comparable with that of sites using twin piezoelectric sensors.

A tube classifier installation does not have capability to detect vehicle length.

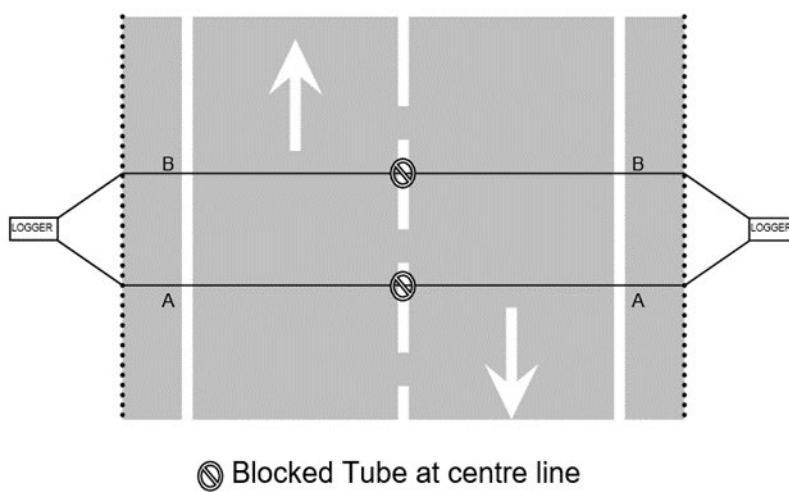
### 7.3.1.1 Single carriageway bi-directional sites

When surveying a single carriageway site with bi-directional traffic, the sensor array configurations can be:

- Two tubes blocked at the centre of the road with one logger per lane (refer to Figure 7.3.1.1(a)), or
- Two tubes across both lanes with no block at the centre with a single logger for both lanes (refer to Figure 7.3.1.1(b)).

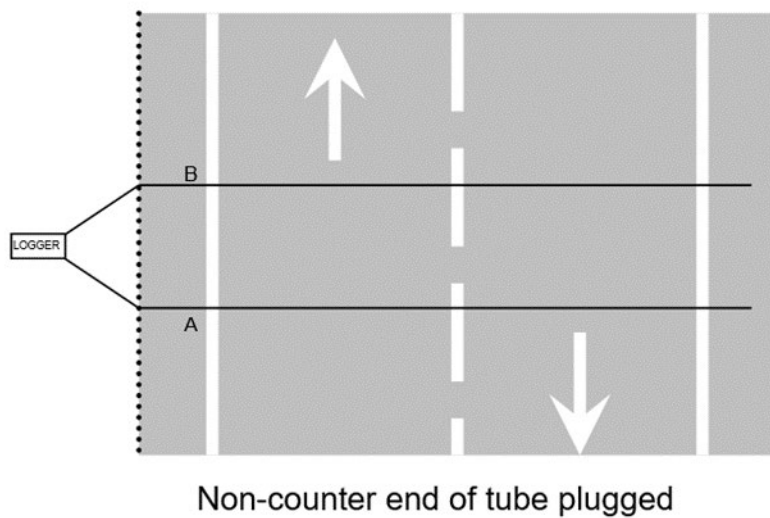
The first configuration (Figure 7.3.1.1(a)) will ensure the best possible accuracy of volume, classification, and speed data. Users must be aware that vehicles that are straddling lanes and that travel over both sensor arrays will be recorded in both lanes.

**Figure 7.3.1.1(a) – Preferred method for surveying single carriageway bi-directional site**



The second configuration Figure 7.3.1.1(b) is used on rural roads with less than 5000 AADT where it is feasible to use one single logger with one set of sensor array across both lanes. Consideration must be given to the level of degradation of data quality. A classification system based on one set of sensor array has finite probability of error when 2 vehicles in opposite directions traverse the sensors simultaneously, making it difficult to decipher the actual vehicle events. This configuration is only suitable for lower traffic volume situations.

**Figure 7.3.1.1(b) – Single carriageway bi-directional site with AADT < 5000**

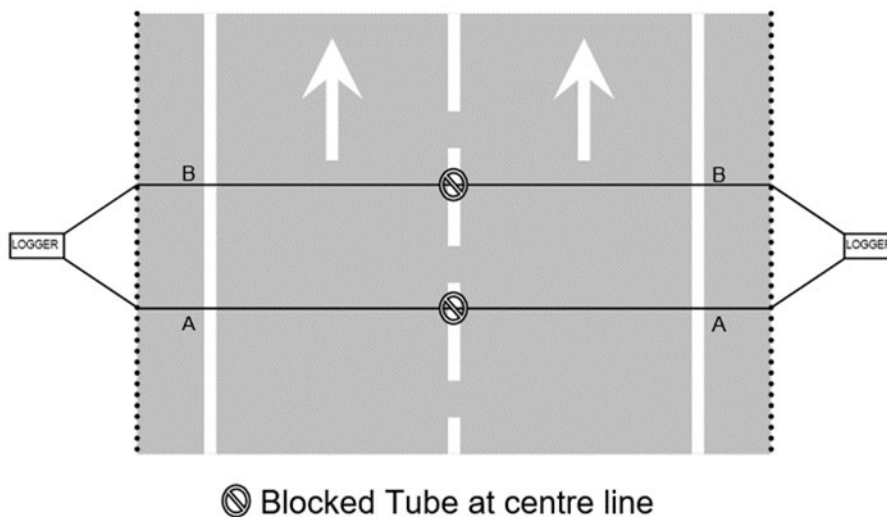


**7.3.1.2 Single carriageway uni-directional sites**

When surveying single carriageways with uni-directional traffic, the preferred sensor configuration is to use two tubes blocked at centre of the road with one logger per lane (refer to Figure 7.3.1.2).

This arrangement will ensure the best possible accuracy of traffic volume, vehicle classification and speed data. Users must be aware that vehicles straddling lanes will be recorded in both lanes by the respective loggers. This will cause error if data of the loggers are treated separately as individual sites. This arrangement is only suitable for up to two lanes. Sites with more than 2 lanes shall use permanent sensor array.

**Figure 7.3.1.2 – single carriageway uni-directional site**



### 7.3.2 Permanent traffic counter / vehicle classifier sensors

Permanent site is for long term data collection use. Both the logger and sensors are permanently installed at site. There are two vehicle classification categories for permanent classifier sensor configuration, namely:

- length-based vehicle classification, and
- axle-based vehicle classification.

Both classification categories depend on the measurement of speed.

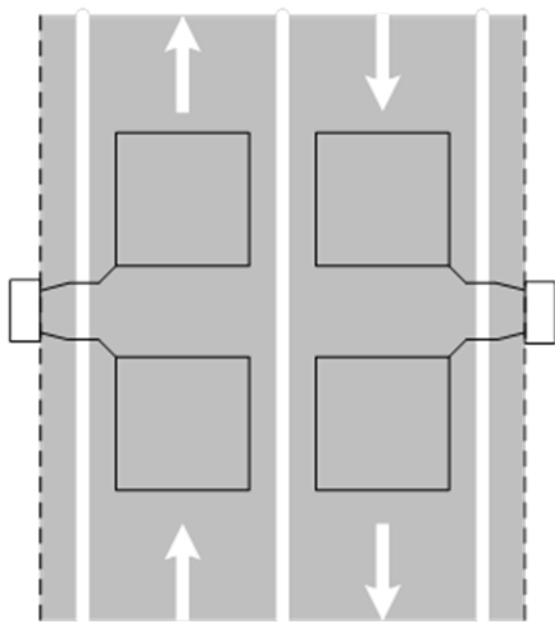
Permanent sites use a combination of sensing technologies: that is, inductive loop and piezoelectric device. Inductive loop enables the detection of vehicle body, whereas piezoelectric sensor allows the detection of vehicle axle. Vehicle travelling speed is calculated by measuring the time difference between 2 inductive loops or 2 piezoelectric sensors installed at a pre-determined spacing. Speed estimated using twin piezoelectric sensors is more accurate than that using twin loops.

#### 7.3.2.1 Length-based vehicle classification

##### 7.3.2.1.1 Loop-Loop sensors

Unless otherwise specified, sensor array used at a length-based traffic counter / vehicle classifier site, which can be installed on a single carriageway bi-directional or dual carriageway multilane road, will be of the Loop-Loop configuration type as shown in SD1920 *ITS – Length based vehicle classifier sensor configuration Loop-Loop*. Figure 7.3.2.1.1 depicts a typical sensor array configuration on a bi-directional carriageway.

**Figure 7.3.2.1.1 – Bi-directional carriageway (loop-loop configuration for length based vehicle classification)**



For detailed configuration and placement of Loop-Loop sensors, refer to SD1920 *ITS – Length based vehicle classifier sensor configuration Loop-Loop*.

### 7.3.2.2 Axle-based vehicle classification

For axle-based vehicle classification, the available options for sensors and their layout include:

- Piezo-Loop-Piezo sensors
- Loop-Piezo-Loop sensors, and
- Piezo-Piezo sensors

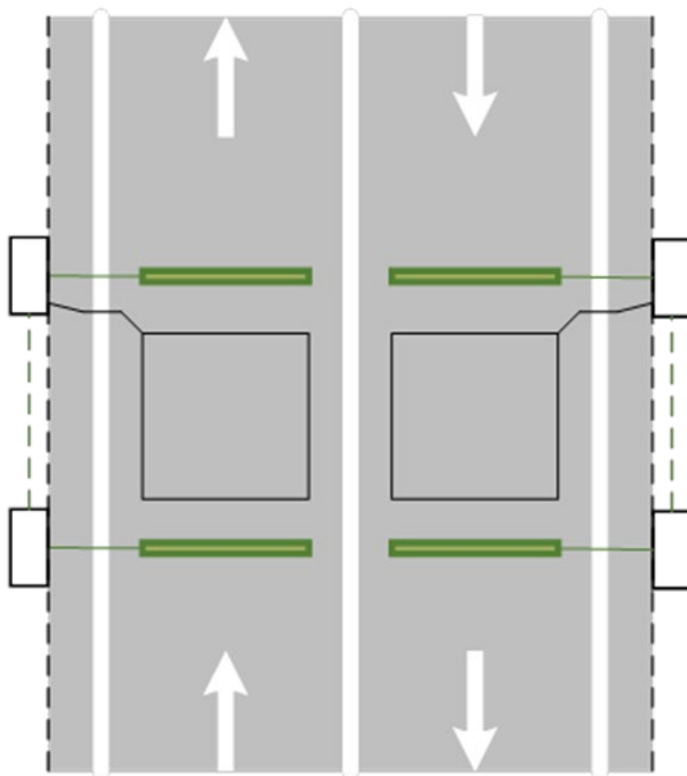
#### 7.3.2.2.1 Piezo-Loop-Piezo sensors

Figure 7.3.2.2.1 demonstrates a typical Piezo-Loop-Piezo configuration used in axle-based vehicle classification sites.

Piezo-Loop-Piezo configuration achieves the highest accuracy level among all sensor configurations for permanent sites. Vehicle length parameter can also be detected with the use of inductive loop placed between the piezoelectric sensors.

For detailed configuration and placement of piezo and loop sensors at different road settings, showing all dimensions and associated road furniture, refer to SD1918 *ITS – Axle-based vehicle classifier sensor configuration Piezo-Loop-Piezo*.

**Figure 7.3.2.2.1 – Typical Piezo-Loop-Piezo configuration on single carriageway bi-directional road**



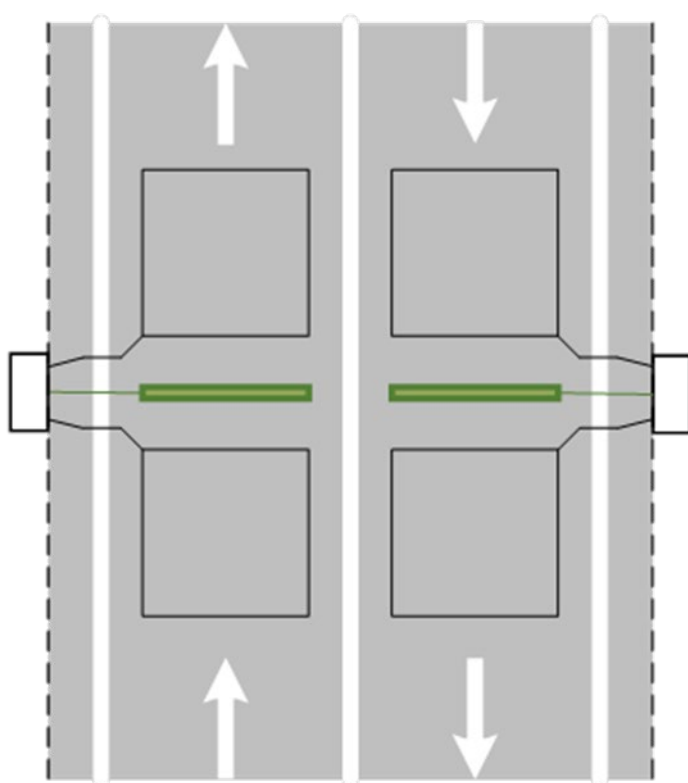
### 7.3.2.2.2 Loop-Piezo-Loop sensors

Figure 7.3.2.2.2 demonstrates a typical Loop-Piezo-Loop configuration used in sites for axle-based classification.

Loop-Piezo-Loop configuration allows the reporting of vehicle axle configuration as well as length parameter. Since it uses 2 loops to estimate vehicle travelling speed, its accuracy is not as high as any site using 2 piezoelectric sensors.

For detailed configuration and placement of piezo and loop sensors at different road settings, showing all dimensions and associated road furniture, refer to SD1917 *ITS – Axle-based vehicle classifier sensor configuration Loop-Piezo-Loop*.

**Figure 7.3.2.2.2 – Typical loop piezo-loop configuration on single carriageway bi-directional road**

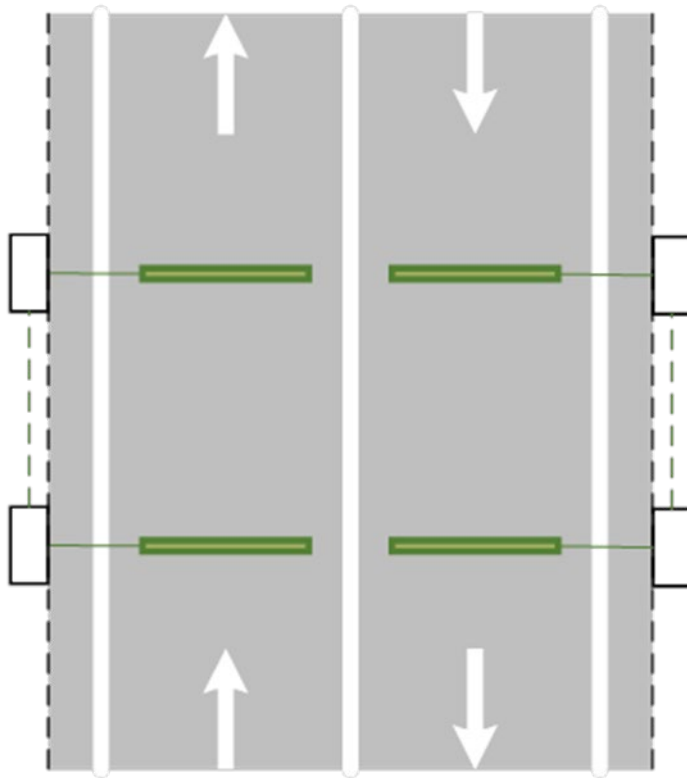


### 7.3.2.2.3 Piezo-Piezo sensors

Figure 7.3.2.2.3 demonstrates a typical Piezo-Piezo configuration used in sites for axle-based classification.

Piezo-Piezo configuration allows the reporting of vehicle axle configuration but without length parameter. Since it uses 2 piezoelectric sensors to estimate vehicle travelling speed, its accuracy is comparable to that of Piezo-Loop-Piezo configuration.

For detailed configuration and placement of piezo sensors showing all dimensions and including the placement of associated road furniture, refer to SD1919 *ITS – Axle-based vehicle classifier sensor configuration Piezo-Piezo*.

**Figure 7.3.2.2.3 – Typical piezo-piezo configuration on single carriageway bi-directional road**

## 7.4 Sensor installation for traffic counter / vehicle classifier site

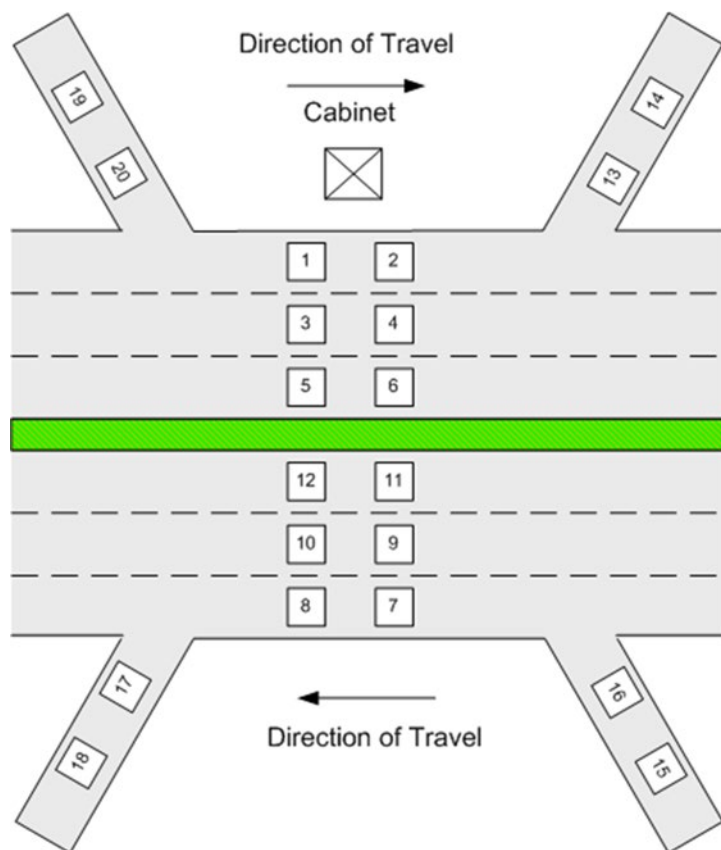
### 7.4.1 Numbering of sensors

This section outlines the recommended numbering sequence for installed sensors. Where a different numbering system is used, it must be documented for future reference.

The following recommended rules apply for the numbering sequence of sensors:

1. The sensors on the travelling direction nearest to the counting equipment (for example, cabinet or logger) shall precede the sensors on the farthest direction.
2. For lanes in the same travelling direction, the sensors on the left lane shall precede the sensors on the right.
3. The leading sensor shall precede the trailing sensor on the same lane.
4. The sensors on the main road shall precede the sensors on the branches (such as on ramp and off ramp). Branch precedence is determined by angular distance in clockwise manner from the cabinet, with reference to the vector from the first sensor (on the main road) to the cabinet.

Refer to Figure 7.4.1 for an illustration of these rules.

**Figure 7.4.1 – Loop numbering for counter / classifier sites****7.4.1.1 Pneumatic tubes**

Pneumatic tubes in a counter / classifier site shall be numbered sequentially according to the numbering rules in Section 7.4.1. For example, the leading and trailing tubes on the lane which is closest to the logger can be numbered as 1 and 2 respectively; the leading and trailing tubes in the opposite direction lane can be numbered as 3 and 4 respectively.

**7.4.1.2 Loops**

Loops in a counter / classifier site shall be numbered sequentially according to the numbering rules in Section 7.4.1. For example, on a dual carriageway 2 lane road with 2 loops on each lane, the loops can be numbered as shown in Figure 7.4.1.

**7.4.1.3 Piezoelectric sensors**

Piezoelectric sensors in a counter / classifier site shall be numbered sequentially as per Section 7.4.1. The examples shown in Figure 7.4.1 is also valid for numbering piezoelectric sensors by substituting loops with piezoelectric sensors in Figure 7.4.1.

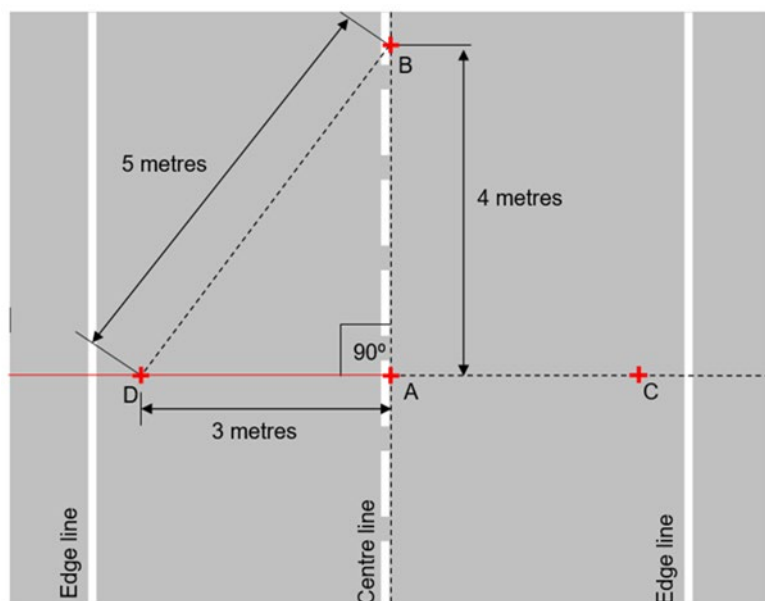
## 7.4.2 Pneumatic tube installation

This section outlines a recommended 10-step procedure for the installation of air tube axle sensors based on field experience. It should be supplemented with the manufacturer(s) installation manual.

The recommended steps for the installation of air tube axle sensors are as follows:

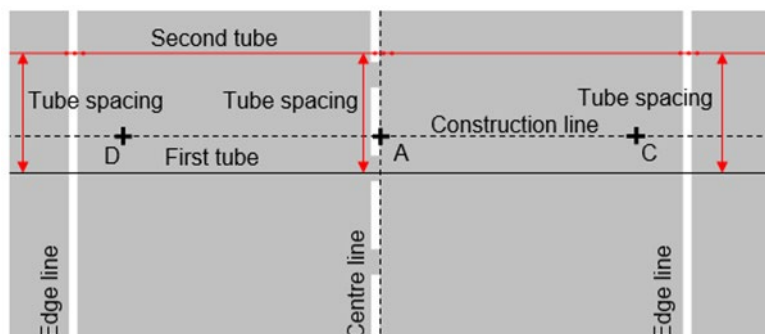
**Step 1 – Construction Line:** Use the 3-4-5 rule (Pythagoras' Theorem) to project a line (AD) perpendicular to the Centre line using the dimensions as shown in Figure 7.4.2(a). Extend the line DA towards C. This is the reference construction line from which tube locations can be offset.

**Figure 7.4.2(a) – Pneumatic tube installation details (Construction Line)**



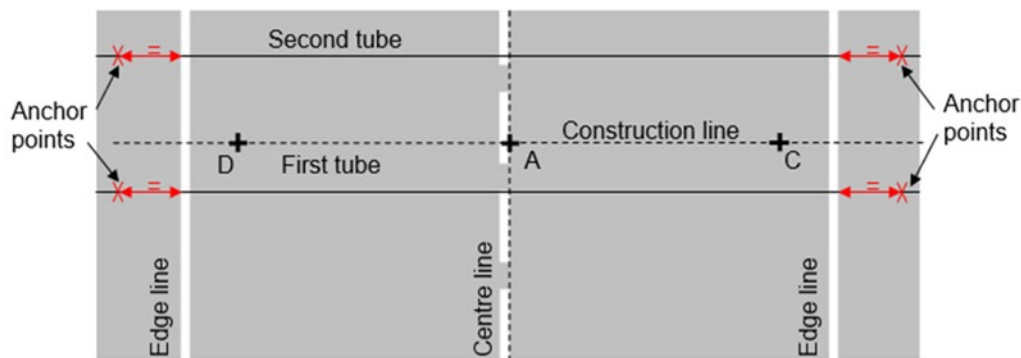
**Step 2 – Determine location of tubes:** Draw two lines parallel to the Construction Line. These are the locations of the first and second tubes respectively. Tube spacing shall be either  $1\text{ m} \pm 2\text{ mm}$  or  $2\text{ m} \pm 2\text{ mm}$  as determined by the Principal. Distance between the first tube and the Construction Line is 500 mm (refer to Figure 7.4.2(b)).

**Figure 7.4.2(b) – Pneumatic tube installation details (determining the location of tubes)**



**Step 3 – Anchor Points:** Mark out anchor points by measuring equal distances into shoulder from edge lines. At sites with narrow seals and unsealed shoulders, the anchor points should be located 100 mm from edge of seal (refer to Figure 7.4.2(c)).

**Figure 7.4.2(c) – Pneumatic tube installation details (Anchor Points)**



**Step 4 – Tube placement:** Prepare 2 round tubes of equal length. Tube length is determined by measuring from anchor point to anchor point, plus enough length to reach the logger at its securing points. If D tubes, instead of round tubes, are used across the traffic lanes, a round tube leader shall be joined to the D tubes by using a brass joiner and be sealed with tape. The round tube leaders for the first and second tubes shall be of equal length. If the tubes require being blocked at the centre line, this can be done by either tying a knot in the exact middle of the tubes or injecting a few squirts of silicone.

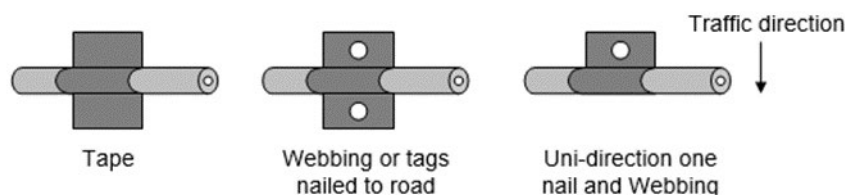
Note: Enough time shall be allowed for silicone to be settle if it is used.

**Step 5 – Tube anchoring and tensioning:** Anchor tubes to road. The portion of a tube between the two anchor points shall be tensioned by stretching the tube by 10% longer during anchoring. It is critical to ensure that the un-tensioned portions of the two tubes, which leads to the classifier at site, are of same length.

**Step 6 – Tube sealing:** Where no logger is to be attached, seal the ends of each tube by tying 2 knots, or inserting a wood dowel and seal with tape.

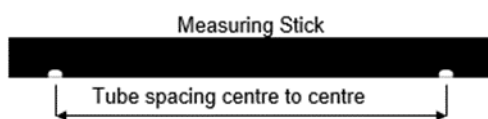
**Step 7 – Tube initial securing:** Secure tubes using any of the methods shown in Figure 7.4.2(d). to minimise lateral movement and maintain constant tube spacing.

**Figure 7.4.2(d) – Pneumatic tube installation details (tube initial securing)**



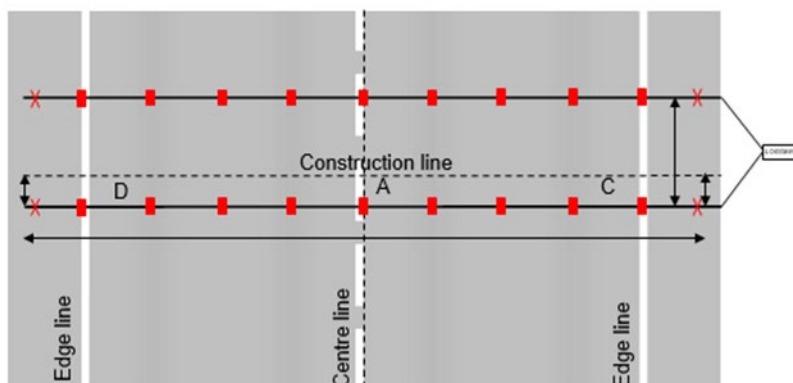
**Step 8 – Tube spacing:** Use a tape measure or measuring stick to ensure that both tubes are spaced correctly, as shown in Figure 7.4.2(e).

**Figure 7.4.2(e) – Pneumatic tube installation details (tube spacing)**



**Step 9 – Tube final securing:** Secure tubes on centre line, then on edge lines, and finally in the middle between centre line and edge lines as shown in Figure 7.4.2(f).

**Figure 7.4.2(f) – Pneumatic tube installation details (tube final securing)**



**Step 10 – Connecting tubes to logger:** Connect tubes into classifier. Ensure both tubes are connected to correct inputs.

**IMPORTANT:** The logger must be placed and secured in a non trafficable area. Slip base poles, including breakaway posts (SD1363, SD1368) and road light poles (SD1372), shall not be used for the purpose of securing the logger or wrapping the air tubes, as this will compromise the safety feature provided by slip base poles.

The contractor must obtain approval from the Principal prior to using any roadside furniture for the purpose of securing the logger and/or tubes.

### 7.4.3 Inductive loop installation

Inductive loop installation for traffic counter / classifier applications shall be as described in Section 6.2.2, except as varied following.

Only 2 m x 2 m square loops shall be used for traffic counter / classifier. Each loop shall have 4 turns (or 5 turns, depending on feeder cable length) to achieve the following electrical characteristics as measured across its input terminals in the cabinet:

- Inductance: 100  $\mu$ H to 250  $\mu$ H
- Resistance:  $\leq 2.5 \Omega$
- Q factor:  $\sim 20$  at 40 kHz

The applicable Standard Drawings for counter / classifier installation are as listed following:

- SD1916 ITS – Axle-based vehicle classifier sensor installation details
- SD1917 ITS – Axle-based vehicle classifier sensor configuration Loop-Piezo-Loop
- SD1918 ITS – Axle-based vehicle classifier sensor configuration Piezo-Loop-Piezo, and
- SD1920 ITS – Length based vehicle classifier sensor configuration Loop-Loop.

## 7.4.4 Piezoelectric sensor installation

### 7.4.4.1 Scope

Piezoelectric sensors are commonly used for vehicle classification and weigh-in-motion applications.

Brass Linguini piezoelectric sensors, which are the predominant piezoelectric sensors used by the department, come in 2 types, based on their output uniformity. The type with uniformity factor of  $\pm 7\%$  or better is suitable for use in counters / classifiers for axle detection and in weigh-in-motion installations for weighing axle loads, whereas the type with uniformity factor worse than  $\pm 7\%$ , typically  $\pm 20\%$ , can only be used in counters / classifiers for axle detection.

The following installation procedures apply only to the piezoelectric sensor of dimensions 1.5 mm thick and 6.5 mm wide. For installation procedures of piezoelectric sensors of different dimensions or sensors other than this technology, for example, quartz crystal sensor, refer to the manufacturers' instructions.

Where Piezo sensors are to be installed into an Open Graded Asphalt (OGA) surface, this shall be done in accordance with the key considerations listed in Section 7.4.4.3.

### 7.4.4.2 Installation procedure

A Brass Linguini piezoelectric sensor is designed for permanent installation into a straight slot on the road surface across the traffic lane in a flexible format so that it can conform to the profile of the road. The dimensions of the slot cut in the road shall comply with this instruction to minimise the impact on the road's structural integrity. The final installation shall be ideally flush with the road surface. Up to 1 mm protrusion is also acceptable; however, no dip is allowed. In most applications, the piezoelectric sensor life expectancy exceeds that of pavement.

**WARNING:** Piezo sensors must not be installed on a bridge deck or any form of structure whose structural integrity could be compromised by the piezo installation process.

Installation procedures are as follows:

1. Mark the location of the first piezo slot at a point in the centre of the road. This will be point A (refer to Figure 7.4.4.2(a)).
2. To ensure the piezo slot is marked exactly perpendicular to the traffic lane, draw a 3 m straight line along the centre line of the road with chalk on either side of point A.
3. Use the 3-4-5 rule (Pythagoras' Theorem) to project a line (AC) perpendicular to the chalk line.
4. Mark out the length of the piezo slot. Verify that the feeder cable length is enough to reach the cabinet.

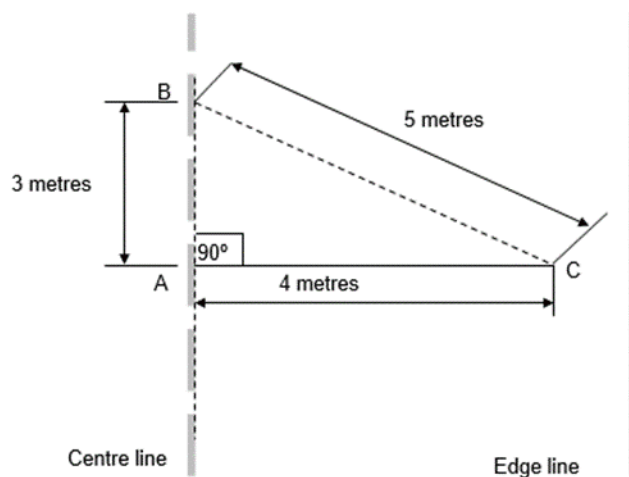
**Do not splice sensor cable if it is too short.**

5. Dry cut the sensor slot using a 19 mm thick (or a stack of multiple thinner blades to form a 19 mm thick) Diamond Blade. The slot must be 19 mm wide  $\pm$  1 mm by a minimum of 25 mm deep. Cut the slot 200 mm longer than the sensor length to accommodate sensor tail or feeder. The direction of cutting should be from the Edge line towards the Centre line of road. This will make it easier for the operator to maintain a uniform depth of slot without adjusting the height of the blade to compensate for change in grade of road.

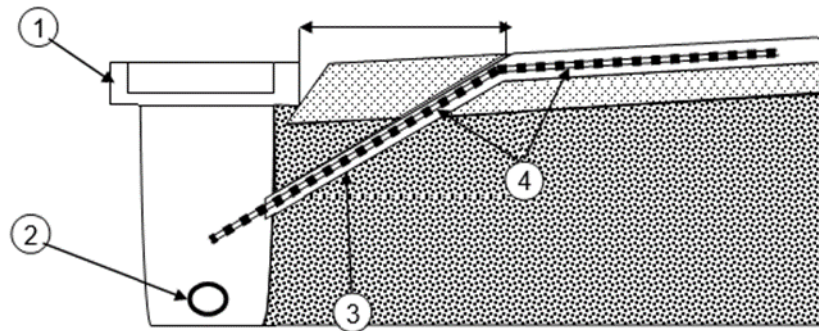
Dry cutting without controls in place to manage dust exposure is banned. Cutting sensor slots needs to have on-tool vacuum extraction system to capture the dust. Depending on the tool used and duration of cutting, workers may also need a respirator to protect themselves.

Refer to Transport and Main Roads *Managing exposure to silica procedure*, RoadTek SMS S001 *Respirable crystalline silica control standard*, RoadTek *Procedure - Selection and use of respiratory protection*, and WHSQ Code of practice – *Managing respirable crystalline silica dust exposure in manufacturing of construction elements*.

**Figure 7.4.4.2(a) – Piezoelectric installation details (location of first Piezo slot)**



6. Cut feeder run slots at 19 mm width. Centre the feeder slot on the sensor slot. Feeder slots are typically cut to a depth of 25 mm stopping 300 mm in from road edge. With a 25 mm core drill bit, drill down through pavement into pit. Before removing the core drill, place 20 mm flexible electrical conduit up the inside drill. Remove the core drill and the conduit will be installed. This method ensures that the cable is protected in its transition from road to pit (refer to Figure 7.4.4.2(b)).

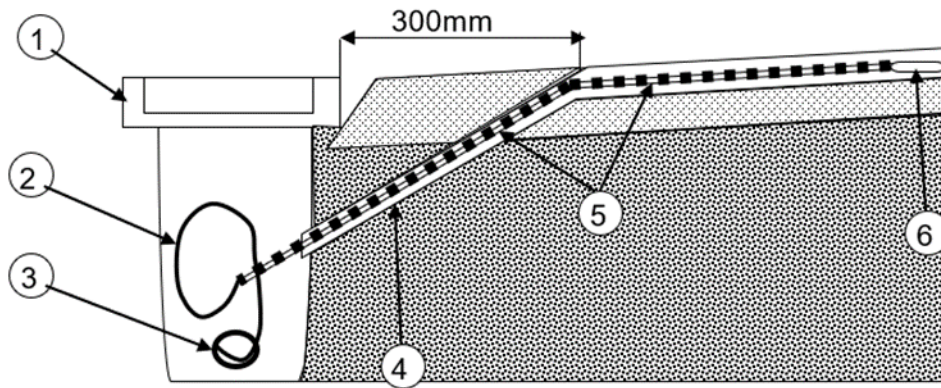
**Figure 7.4.4.2(b) – Piezoelectric installation details (feeder slot to pit arrangement)**

## NOTES

1. Electrical Cable Pit
2. Conduit
3. Core Drill down through pavement into pit
4. Flexible conduit from piezo join into pit

7. Vacuum-clean all slots to ensure they are free of dust or debris, and then dry all slots with compressed air and/or gas burners.
8. Remove sensor from packaging. Visually inspect sensor to ensure it is straight without any twists or curls. Check feeder cable for bare wire. Check joint for cracks or gaps. Sensors having any of these issues shall not be used. Refer to the QC test data sheet (enclosed inside the package) to ensure the correct sensor is to be installed. Verify that there is sufficient feeder cable with intact insulation to reach the cabinet.
9. Measure capacitance, dissipation factor and insulation of the sensor. Capacitance and dissipation should be within  $\pm 20\%$  of the enclosed data sheet. Resistance should be infinite when measured using an ohmmeter with a 20 M $\Omega$  range setting. Record the result of the measurements.
10. Place sensor next to the slot. From this point forward, handle the sensor with latex (or equivalent) gloves.
11. Clean sensor with steel wool or emery pad. Wipe down with alcohol and clean lint free cloth.
12. Place installation brackets on sensor every 150 mm for the length of the sensor. Use the 20 mm (small) brackets supplied together with the sensor. Thread feeder cable through flexible conduit.
13. Place sensor in the sensor slot. The end of the sensor should be at least 50 mm from the end of the slot, and the tip shall not touch the bottom of the slot. The lead attachment or joint shall not touch the bottom or the sides of the slot.
14. If any of the 3/4" 20 mm (small) brackets do not fit snugly against the sides of the slot or are loose, replace with a 25 mm (large) bracket and repeat Step 13.
15. Starting at the non-lead end, use the installation depth gauge to position the sensor so that it is 9 mm below the surface of the road by pressing the depth gauge against the top of the sensor. At this point, the installation bracket is 3 mm below the surface of the road.
16. Visually inspect the length of the sensor to ensure it is at uniform depth along its length and it is level and not twisted.
17. Run the feeder wire the length of the feeder slot (refer to Figure 7.4.2.2(c)).

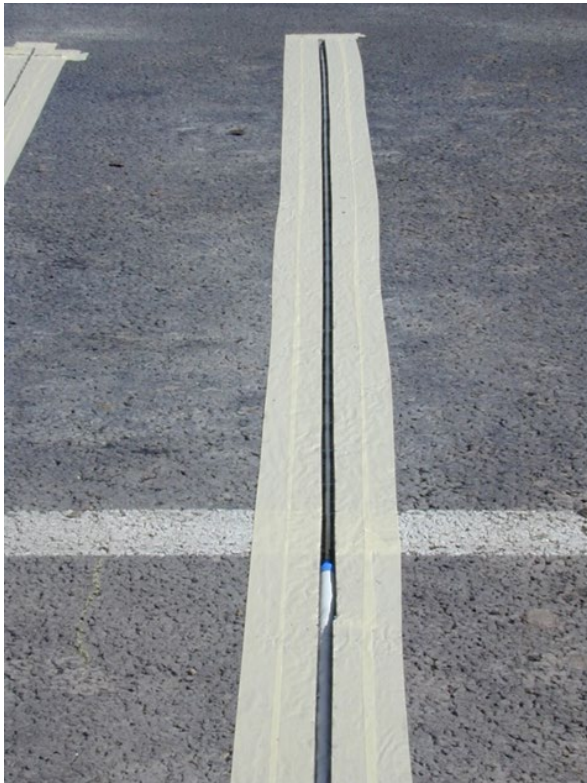
**Figure 7.4.2.2(c) – Piezoelectric installation details (feeder cable to pit arrangement)**



1. Electrical Cable Pit
2. Piezo cable
3. Conduit
4. Core Drill down through pavement into pit
5. Flexible conduit from piezo join into pit
6. Piezo join

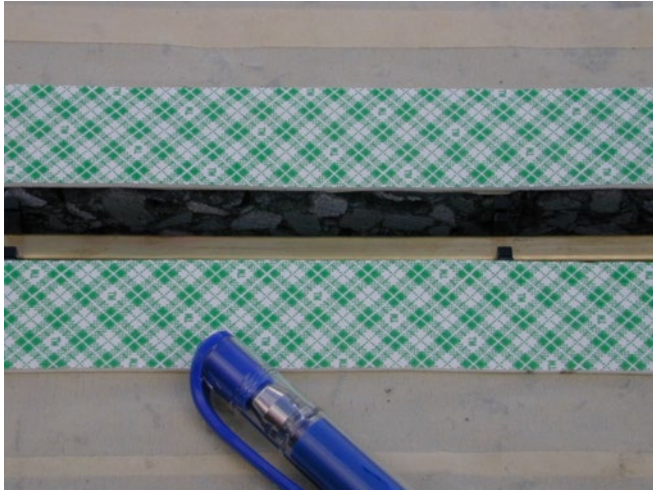
18. Seal conduit and feeder cable with a sealant to prevent epoxy running down into pit.
19. Place 50 mm masking tape along the length of both sides of the sensor slot. Tape must be 2 mm away from the slot.
20. Place another 50 mm masking tape along the length of the first row of tape ensuring a 5-10 mm overlap. This will allow excess epoxy to be removed easily (refer to Figure 7.4.4.2(d)).

**Figure 7.4.4.2(d) – Piezoelectric installation details (preparation of sealant feeder slot)**



21. Adhere double sided tape on top of the first row of masking tape on both sides, ensuring 2 mm away from the slot. Do not remove paper covering the adhesive. This provides a 2-3 mm formwork above the road surface level. When the slot is filled with epoxy to the level of the double-sided tape, it ensures that epoxy is 2-3 mm proud of the road surface (refer to Figure 7.4.4.2(e)).

**Figure 7.4.4.2(e) – Piezoelectric installation details (preparation of sealant feeder slot continuation)**



22. Using low speed mixing drill (450 rpm) and a mixing paddle, premix both parts of the epoxy as per manufacturer's instructions.
23. Add hardener to epoxy and mix according to manufacturer's instructions.
24. Immediately pour epoxy into the slot using a small bead. Using a small bead allows the installer to watch the epoxy flow under the sensor, eliminating air pockets. Start at the end and pour towards the lead attachment. Repeat until slot is overflowing the level of the double-sided tape slightly.

**DO NOT FILL SLOT IN ONE PASS.** This will introduce air pockets under the sensor.

25. Using putty knife, start at the lead attachment and lightly screed towards the end of the Piezo ensuring in that there is enough epoxy to keep a uniformed height along the length of the slot (refer to Figure 7.4.4.2(f)).

**Figure 7.4.4.2(f) – Piezoelectric installation details (feeder slot sealant application)**



26. Remove tape as soon as epoxy begins to set (2-5 min) (refer to Figure 7.4.4.2(g)).

**Figure 7.4.4.2(g) – Piezoelectric installation details (removal of sealant excess)**



27. Once epoxy is cured, use a belt sander to sand the top of the epoxy. For WiM sensors, the epoxy finish should be flush or no more than + 1 mm proud of roads surface. For classifier sensors, the epoxy finish should be 1 mm to 2 mm proud of roads surface. Regardless of finish epoxy height, it must be uniform height along the sensor length. If the epoxy finish is low anywhere along its length, it must be topped up with additional epoxy (refer to Figure 7.4.4.2(h)).

**Figure 7.4.4.2(h) – Piezoelectric installation details (making epoxy level with road surface)**



28. Wait allotted period, as prescribed in the material datasheet, to allow epoxy to fully cure and then open the lane to traffic.
29. Connect an oscilloscope to sensors and view wave forms as vehicles pass. Ensure signal is clear without noise.

#### **7.4.4.3 Installation of piezoelectric sensor on Open Grade Asphalt (OGA) pavement**

Open Graded Asphalt (OGA) is often specified for the road surface on high-speed, multi-lane roads such as freeways, highways, and heavily trafficked urban roads. It is different to other asphalt mix types, as it is designed to be permeable and allow for surface water to drain vertically through the OGA layer to an impermeable waterproofing seal and then laterally to the edge of the pavement. It is very important that an outlet be provided for the water that enters an OGA, otherwise, the layer deteriorates due to the ongoing presence of moisture in the layer. For this reason, OGA must have a free draining edge and be placed above the lip level of any adjacent kerb and channel.

OGA contains a large proportion of coarse aggregate and only a small amount of fine aggregate, resulting in a high interconnected void content between 20-25%, which makes the asphalt highly permeable. This in turn reduces the risk of vehicles aquaplaning in wet weather, due to the rapid removal of water from the surfacing. Another safety benefit is a reduction in water spray which results in improved visibility in wet weather. OGA has also been used in areas where a reduction in tyre road noise generation is required, as it has a high negative texture.

The nominal size of the aggregate used for OGA is either 10 mm or 14 mm and generally placed at a thickness of approximately three times the nominal aggregate size (refer to Technical Specification MRTS30 *Asphalt Pavements* for layer thickness requirements). Due to its composition and high air voids content, OGA has a shorter life expectancy than dense graded asphalt and does not perform as well in areas where high shear forces can be expected, such as heavily trafficked intersections.

The installation of piezo sensors into asphalt wearing course, as shown on departmental SD1906 *ITS - WIM Piezo Sensor Installation Details*, requires a 19 mm wide x 25 mm deep slot be cut into the surfacing. A polyurethane suitable epoxy resin sealant is then used to fill the slot to protect the wires, it is important that only departmental approved products are used in the construction and maintenance of infrastructure projects.

Piezo sensors are installed in pavement at locations where Austroads 12 bin vehicle classification data is required. Brass piezo sensors may be installed in OGA, however precautions are to be applied to ensure installations are not problematic due to several reasons.

Firstly, as OGA is porous, it is critical that the layer remains free draining. If the drainage path is blocked within the asphalt layer, the asphalt mix can remain in a moist condition state well after rainfall ceases. The long-term presence of moisture within the layer will typically lead to premature stripping and ravelling of the asphalt. To minimise this risk, it is important that the depth of cut be limited to 25 mm.

Secondly, where Piezo sensors are to be installed into an OGA surface, it is important that designers carefully consider the impact that the installation will have on the drainage properties of OGA. Given this, it is important that these piezo sensors are installed in locations where the road surface drainage paths are relatively short, and the design water film depth is below the desirable limit. Conversely, installing piezo sensors in locations where the road surface drainage paths are relatively long and/or the design water film depth is above the desirable limit, should be avoided.

Lastly, any saw cuts in an asphalt surfacing will represent a point of weakness. This weakness will be more pronounced in an OGA surfacing (when compared to other asphalt types) and may be more prone to premature ravelling / potholing in the longer term. Departmental experience is that, when polyurethane epoxy resin fillers are used, premature pavement failure has not occurred.

Where inductive loops are installed in conjunction with piezo sensors in new pavements, for best pavement performance, preformed loops are to be used, installed below the wearing layer in accordance with departmental SD1424 *Traffic Signals – Detector Loops Installation Details*.

To ensure optimum performance of both the pavement and the sensors, brass piezos shall be cut into OGA under the following conditions:

- Piezo slot depth is not to exceed 25 mm
- Piezo sensors are not to be installed on vertical curves
- Piezo sensors are not to be installed on longitudinal grades exceeding  $\pm 2\%$
- Piezo sensors are only to be installed in pavements with a - 3% crossfall, and
- Piezo slot to be sealed with polyurethane epoxy resin in accordance with the departmental standard drawing.

## **8 Placement and installation of high-speed weigh-in-motion sensors**

A WiM site requires a combination of inductive loops, piezoelectric sensors and/or strain gauges.

The function of inductive loops is to detect the presence of a vehicle. Vehicle length parameter can be estimated with the speed and duration of the vehicles being detected. Inductive loops used in WiM sites shall be of the same characteristics used in classifier / counter placement detailed in Section 7.4.3.

Brass Linguini piezoelectric sensors come in multiple grades, based on their output uniformity. The piezoelectric sensors for weighing function shall have a uniformity factor of  $\pm 7\%$  or better as a minimum requirement. A pair of piezoelectric sensors of constant spacing in a WiM site also allows the detection of vehicle travelling speed.

Strain gauge used in WiM sites is a machine milled steel bar of dimensions 300 mm (L) x 30 mm (W) x 6 mm (T). The central section of the bar is milled into a 30 mm diameter ring. Attached to this ring is a Wheatstone bridge and a buffer amplifier circuit which converts electrical resistance changes, caused by deflection of the gauge, to electrical current, before feeding the current signal to a data acquisition system unit.

### **8.1 Site selection**

For the WiM system to perform properly, the Contractor shall provide and maintain an adequate operating environment for the system's sensors and instruments. Proper selection, construction, and maintenance of each WiM site, including maintenance of the sensors, are extremely important.

The following site conditions shall be provided, as a minimum, by the Contractor to consistently meet the specified performance criteria.

This applies to both new road constructions where a WiM site is specified and an existing road installation. The Contractor is responsible for any Site assessments and investigations required to satisfy the site conditions.

#### 8.1.1 Horizontal curvature

The horizontal curvature of the roadway lane for 100 m in advance of and 50 m beyond the WiM system sensors shall have a radius not less than 1700 m measured along the centreline of the lane.

#### 8.1.2 Longitudinal gradient

The longitudinal gradient of the road surface for 100 m in advance of and 50 m beyond the WiM system sensors shall not exceed  $\pm 2\%$ .

#### 8.1.3 Cross carriageway gradient

For bi-directional single carriageways, the cross slope (lateral gradient) of the road surface for 100 m in advance of and 100 m beyond the WiM system sensors shall not exceed - 3%.

For dual carriageways, the cross slope (lateral gradient) of the road surface for 100 m in advance of and 50 m beyond the WiM system sensors shall not exceed - 3%.

#### 8.1.4 Lane width and line markings

The width of the paved roadway for 100 m in advance of and 50 m beyond the WiM system sensors shall accommodate a sealed shoulder of minimum 1.0 m wide on each side of the road and 3.5 m per trafficable lane.

The trafficable lane is the portion of the road devoted particularly to the use of vehicles moving in a forward direction as demarcated by appropriate line markings which shall be 100 mm to 150 mm wide.

#### 8.1.5 Surface evenness

Roadway surface evenness contributes to the accuracy of weighing vehicle axles. Table 8.1.5 provides indicative surface evenness parameters required to achieve the expected accuracy of a WiM site. Rutting is measured with a 3 m straightedge placed anywhere within a lane, whereas road roughness count is measured at 20 m intervals. These parameters apply to the paved roadway 100 m in advance of and 50 m beyond the WiM system sensors.

**Table 8.1.5 – Indicative surface evenness parameters**

Evenness parameters	Single axle weighing accuracy (95% confidence level)		
	$\pm 15\%$	$\pm 20\%$	$\pm 30\%$
Rutting (3 m straightedge)	$\leq 4$ mm	$\leq 7$ mm	$\leq 10$ mm
Roughness (NRM)	$< 33$ counts per km	$< 70$ counts per km	$< 105$ counts per km

In the event that the site fails the surface evenness test, and no alternative site is available, the Principal shall advise if a corrective course and tie ins to the existing pavement are required. The preparation and application for the corrective course and tie ins shall comply with MRTS30 *Asphalt Pavements*.

#### **8.1.6 Lane discipline**

The WiM site should be located on a carriageway that allows free flowing traffic for vehicles to travel at a constant speed within the same lane, preferably close to the regulatory sign posted speed.

#### **8.1.7 Free flowing traffic**

The WiM site selected shall allow for free-flowing traffic. Changes in vehicle speeds will affect data accuracy in weight, classification, and speed. Vehicles travelling under 30 km/h will not be accurately weighed.

Consideration should be given to avoid locations in the vicinity of intersections, caravan parks, small shopping centres, locations with overtaking lanes and areas with frequent congestion.

#### **8.1.8 Free of flooding**

The selected location for the WiM site should have nil risk of flooding. The pavement shall be well drained.

### **8.2 Applicable standard drawings**

Sensor placement and installation at WiM sites shall be in accordance with the sections following as well as the details in the following Standard Drawings:

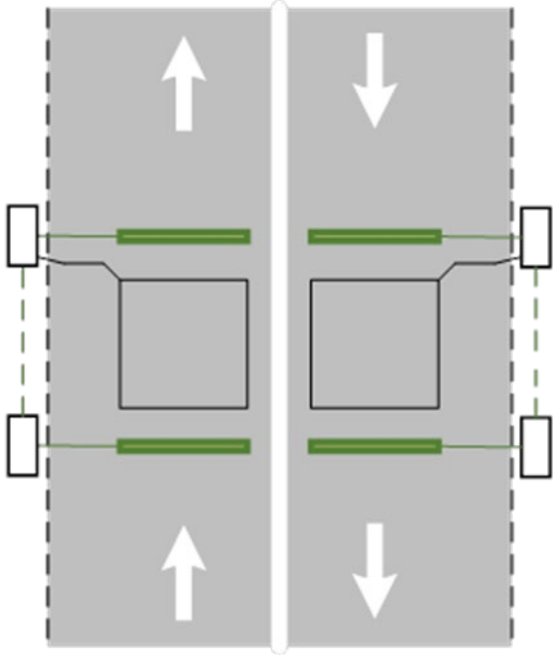
- SD1906 *ITS – WiM Piezo Sensor Installation Details*
- SD1908 *ITS – WiM Sensor Configuration Piezo-Loop-Piezo*
- SD1909 *ITS – WiM Sensor Configuration Piezo-Piezo -Loop- Piezo-Piezo*
- SD1910 *ITS – WiM Sensor Configuration Piezo-Piezo, and*
- SD1911 *ITS – WiM Sensor Configuration Strain Gauge Sensor.*

### **8.3 Sensor placement at high-speed weigh-in-motion site**

#### **8.3.1 Piezo-Loop-Piezo weigh-in-motion**

Figure 8.3.1 shows a typical Piezo-Loop-Piezo configuration used in WiM sites. For detailed configuration and placement of Piezo-Loop-Piezo at different road settings, showing all dimensions and associated road furniture, refer to SD1908 *ITS – WiM Sensor Configuration Piezo-Loop-Piezo*.

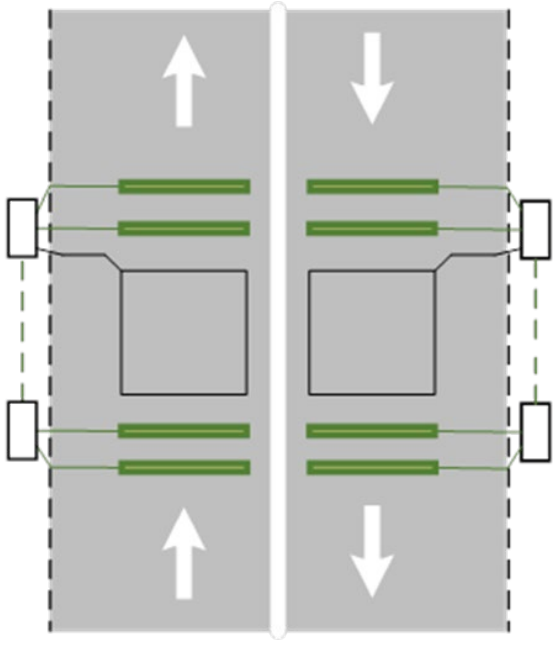
**Figure 8.3.1 – Single lane bi-directional carriageway (Piezo-Loop-Piezo configuration for weigh-in-motion sites)**



**8.3.2 Piezo-Piezo-Loop- Piezo-Piezo weigh-in-motion**

Figure 8.3.2 shows a typical Piezo-Piezo-Loop-Piezo-Piezo configuration used in WiM sites. This configuration is intended to reduce error by collecting more weighing samples of an axle. For detailed configuration and placement of Piezo-Piezo-Loop-Piezo-Piezo at different road settings, with all dimensions and associated road furniture, refer to SD1909 ITS – WIM Sensor Configuration Piezo-Piezo-Loop-Piezo-Piezo.

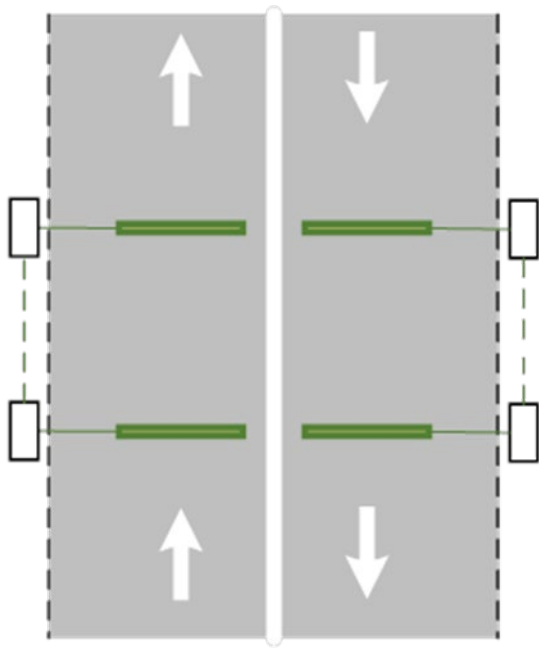
**Figure 8.3.2 – Single lane bi-directional carriageway (Piezo-Piezo-Loop-Piezo-Piezo configuration for weigh-in-motion sites)**



### 8.3.3 Piezo-Piezo weigh-in-motion

Figure 8.3.3 shows a typical Piezo-Piezo configuration used in WiM sites. This configuration does not have loop and is, therefore, unable to detect vehicle length. For detailed configuration and placement of Piezo-Piezo at different road settings and showing all dimensions and associated road furniture, refer to SD1910 *ITS – WIM Sensor Configuration Piezo-Piezo*.

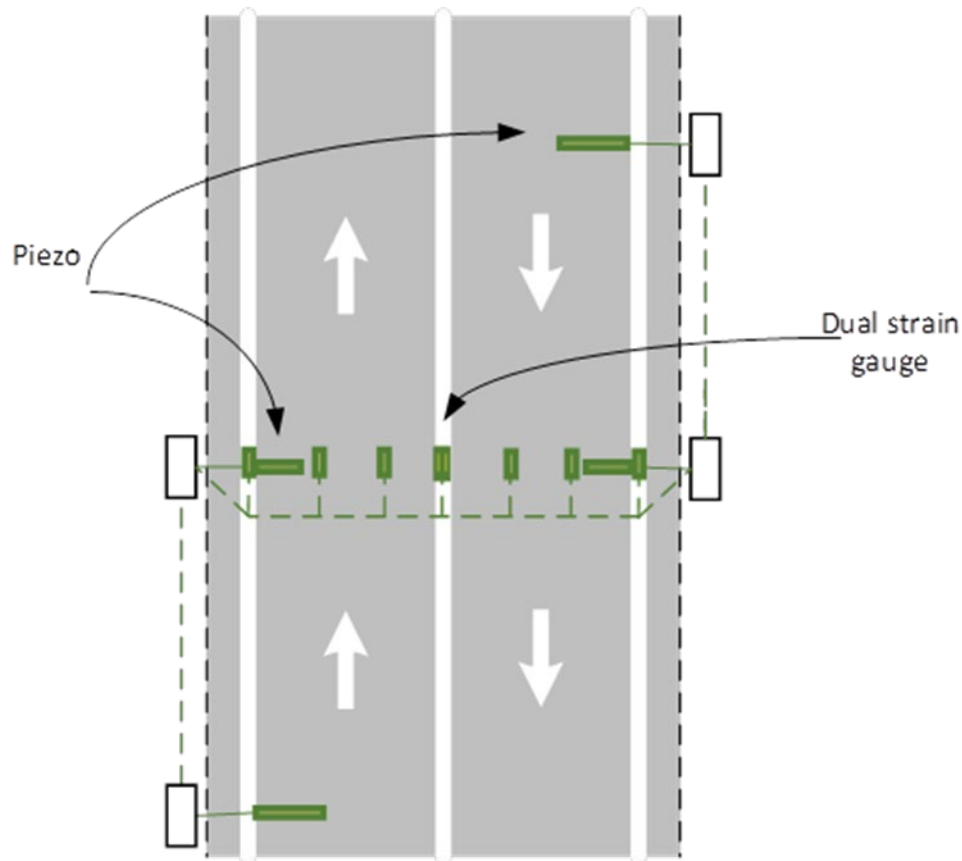
**Figure 8.3.3 – Single lane bi-directional carriageway (Piezo-Piezo configuration for weigh-in-motion sites)**



### 8.3.4 Strain gauge weigh-in-motion

A typical strain gauge WiM site has 4 strain gauges installed on the soffit of the culvert under each lane to measure the deflection of the culvert caused by the weight load above it. Each lane shall also have a pair of piezoelectric sensors (1.83 m in length) installed on the pavement to detect vehicle speed. Figure 8.3.4 shows a typical strain gauge sensor configuration used in WiM sites. For detailed configuration and placement of strain gauge sensors at different road settings and with all dimensions and associated road furniture, refer to SD1911 *ITS – WIM Sensor Configuration Strain Gauge Sensor*.

**Figure 8.3.4 – Single lane bi-directional carriageway (strain gauge sensor arrangement for weigh-in-motion sites)**



The culvert of an ideal Strain Gauge WiM site shall exhibit the following characteristics:

- Reinforced concrete box culverts with simply supported lids of size 1200 mm span, with a depth of about 1200 mm is preferred. Inverted box culverts with spans of 1800 mm to 3000 mm are also acceptable. Short span inverted culverts under 1200 mm shall not be used.
  - The depth of fill should be 600 mm at the minimum, assuming that roads have a 3% crossfall.
  - The culvert should be square to the road.
  - The soffit of the culvert should be free of cracks.
  - The box culvert sections should be in modules 1200 mm long.

## **8.4 Sensor Installation at high-speed weigh-in-motion site**

### **8.4.1 Numbering of sensors**

#### **8.4.1.1 Loops**

The numbering of loops as described in Section 7.4.1.2 applies to numbering of loops in WiM sites.

#### **8.4.1.2 Piezoelectric sensors**

The numbering of loops as described in Section 7.4.1.3 applies to numbering piezoelectric sensors in WiM sites.

#### **8.4.1.3 Strain gauges**

Strain gauges in a WiM site shall be numbered sequentially, according to the numbering rules in Section 7.4.1.

#### **8.4.2 Inductive loop installation**

The inductive loop sensor installation details described in Section 7.4.3, and the relevant Standard Drawings listed in Section 8.2, apply to WiM sites.

#### **8.4.3 Piezoelectric sensor installation**

The piezoelectric sensor installation details described in Section 7.4.4 and the relevant Standard Drawings listed in Section 8.2 apply to WiM sites.

#### **8.4.4 Strain gauge installation**

In the department's weigh-in-motion application, strain gauges are transducers installed on the soffit of a culvert. The associated buffer amplifiers are installed in the field cabinet with the data acquisition system. Each transducer, its associated buffer amplifier and the cable that connects the transducer with the amplifier are pre matched and pre calibrated by the manufacturer and, therefore, are not interchangeable. The cables must not be cut, extended, or joined. Excessive cable length shall be coiled and stored inside field cabinet.

SD1911 *ITS – WiM sensor configuration Strain Sensor* shows the placement of strain gauges and associated devices within a culvert. Holes are drilled into the concrete structure that match the transducer mounting holes. Threaded expanding-head bolts are inserted, spacer washers are fitted, then the strain transducer is secured with dyna bolts.

When securing each strain transducer, care shall be exercised to prevent excessive deformation of the device which could cause permanent damage. Modest deformation will result in an electrical output offset that, in most cases, can be balanced by adjusting the associated buffer amplifier. Greater deformation may require the re tensioning of the securing bolts; however, in severe cases, the repositioning and reinstallation of the securing bolts may be necessary.

After the transducer is properly installed, a polystyrene foam thermal insulating cover is fitted over the transducer. The insulators of the cover can minimise temperature differential between the transducer and the culvert soffit where the transducer is mounted. Rapid ambient temperature changes around the transducer could occur due to wind gusts through the culvert.

Upon completion of installation, every strain measuring channel – that is, transducer in association with its buffer amplifier – shall be re-calibrated. Refer to manufacturer's instructions for calibration procedures.

### **9 Placement and installation of active transport sensors**

This section applies to the placement of Active transport counter and classifier (ATCC) sensors on shared or separated pedestrian and bicycle paths as defined in Austroads AGRD06A-17 *Guide to Road Design Part 6A: Paths for Walking and Cycling*.

The primary purpose for the installation of active transport sensors is to measure the utilisation of the facility by counting the traffic volumes of different kinds of active transport users, including pedestrians, cyclists, and riders of scooters.

Section 9.3 discusses the sensor technologies currently used in Transport and Main Roads active transport paths.

### **9.1 Site selection**

Active transport sites may use different sensing technologies, including pneumatic tube (for temporary bicycle counting), piezoelectric sensor (for permanent bicycle counting), passive infrared sensor (for pedestrian counting), and video analytics camera (to identify, count and classify pedestrians, bicycles, scooters, and prospective personal mobility devices). Display units may also be added as optional to some active transport sites to provide information for path users. However, placement and installation of a display unit is out of scope of this manual.

The general site selection considerations for traffic counters/classifiers prescribed in Section 7.1 also apply to the selection of suitable location for active transport site. In addition, for active transport, site locations with any of the following characteristics should be avoided:

- locations where path users may stop, turn, or gather, resulting in double counting
- locations where path users need to make turns or where the path is divided / split
- locations where path users may stop or park on or over sensors of the site
- locations that have poor lane discipline and frequent lane changing
- for sites using piezoelectric sensors or pneumatic tubes, locations where active transport personal mobility device will not cross perpendicularly to the piezo or tube sensors
- locations where path users may accelerate or decelerate due to geometry, traffic signals, or intersections unless the site functions as ancillary input to traffic signal controller which is out of scope of this section
- locations where speeds may exceed 40 km/h (11.1 m/s), particularly for site that has display unit, which may be a safety hazard to cyclists travelling at high speed
- locations where the detection of a path user could be obstructed by another path user
- locations where there is poor access for installation and maintenance crews
- locations with poor surveillance, and
- locations that limit solar energy harvesting due to vegetation or high-rise buildings.

For sites using Video Analytics (VA) cameras, the following site features should be avoided:

- locations that have poor illumination unless the camera has night vision capability
- locations where there is obstruction or a likelihood of obstruction (e.g. due to vegetation) of line-of-sight between camera and detection zone
- locations with insufficient clearance for offsetting the camera pole
- locations where the footpath / cycle path has a horizontal curvature radius (R) not satisfying the conditions prescribed in Section 9.3.3.4
- locations with non-flat longitudinal gradient. The slope of the cycle path leading to detection zone should be gentle, if not completely flat, to limit cyclists from accelerating beyond a speed the camera can capture. Site should cater for a speed of 40 km/h (11.1 m/s), and
- locations where bicycle speed could go beyond 45 km/h (12.5 m/s).

## 9.2 Applicable standard drawings

- SD1928 ITS – Bicycle counter
- SD1929 ITS – Bicycle and pedestrian counter, and
- SD1930 ITS – Video analytics active transport classifier

## 9.3 Sensor placement at active transport site

Active transport counter and classifier (ATCC) sites may use pneumatic tube, piezoelectric sensor, PIR sensor, and video analytics cameras as detailed in the table below. The following sections discuss the placement of these sensors for various applications.

**Table 9.3 – ATCC sensors**

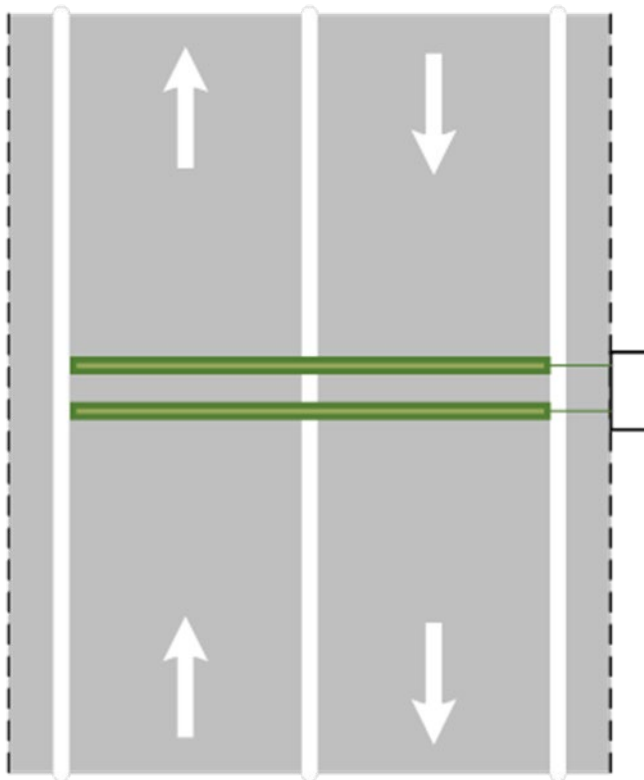
Sensing technology	Targets	Remarks
pneumatic tube	bicycle, scooter	<ul style="list-style-type: none"> <li>• suit temporary site only as not requiring pavement cutting, and</li> <li>• unable to differentiate bicycle and scooter</li> </ul>
piezoelectric sensor	bicycle, scooter	<ul style="list-style-type: none"> <li>• requires pavement cutting, and</li> <li>• unable to differentiate bicycle and scooter</li> </ul>
PIR sensor	pedestrian	<ul style="list-style-type: none"> <li>• animals could be mistaken as pedestrians</li> </ul>
video analytics camera	bicycle, scooter, pedestrian, undetermined object	<ul style="list-style-type: none"> <li>• site specific AI training is required</li> </ul>

### 9.3.1 Bicycle counter

A typical cycle path is a 3 m wide (between edge lines) single carriageway corridor for bi-directional cycling traffic movement. To construct a bicycle counter, a pair of piezoelectric sensors are installed across the path from one edge line to the edge line on the opposite side, perpendicular to the centre line. Spacing between the piezoelectric sensors shall be 300 mm. This configuration enables the counting of bicycles in each of the travelling directions. For dimensions and other details, refer to SD1928 ITS – Bicycle counter.

A piezoelectric sensor-based bicycle counter is unable to differentiate bicycle, scooter, and any 2-axle personal mobility device, though axle spacing parameter can be calculated. Data reported from a site of this kind is the count of all bicycle-like traffic.

Figure 9.3.1 exhibits a typical Piezo-Piezo bicycle counter configuration. For non-permanent bicycle counting site, pneumatic tubes may be installed in lieu of piezoelectric sensors.

**Figure 9.3.1 – Typical Piezo-Piezo configuration for bicycle counter**

For heavy traffic sites, the designer should consider having a pair of piezoelectric sensors on each lane of the path, to reduce the probability of having multiple cyclists concurrently rolling over the same piezoelectric sensor causing errors in detection.

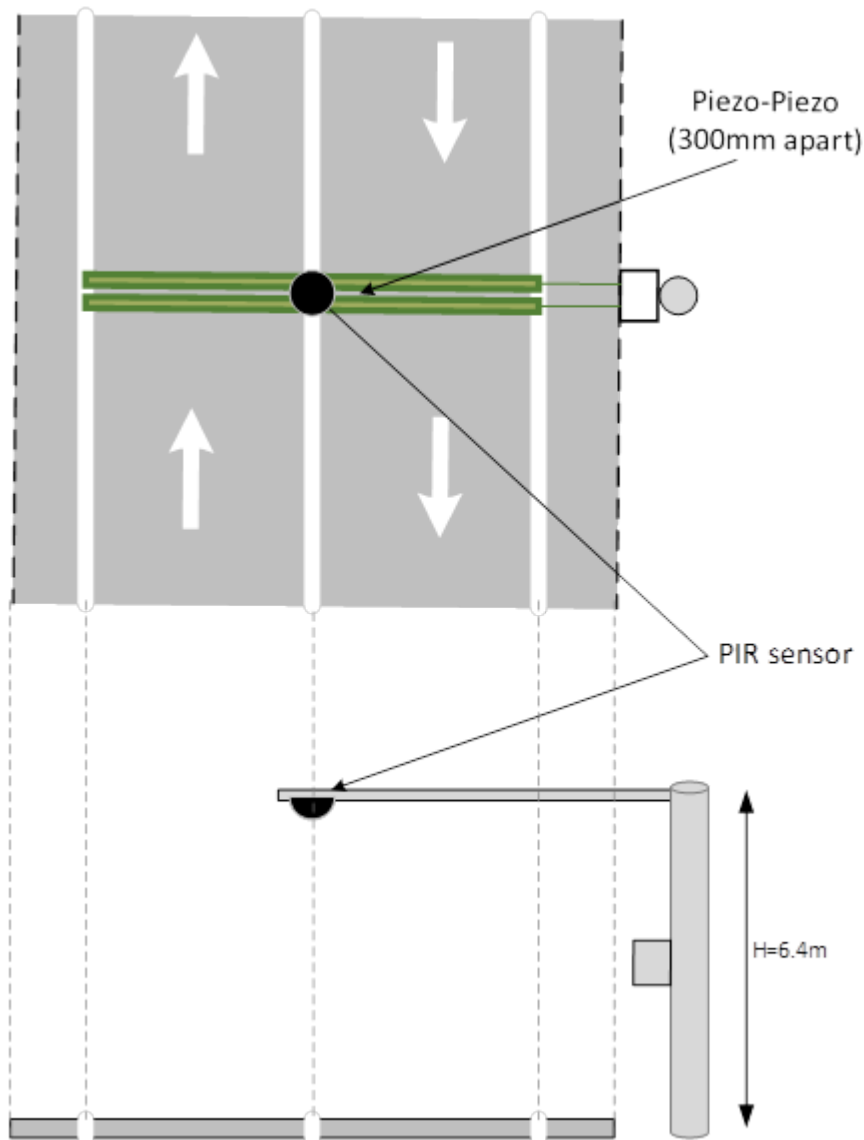
### 9.3.2 Collocated bicycle and pedestrian counter

Pedestrian counters use passive infrared (PIR) sensing technology to detect the presence of an object which has a differentiable temperature signature against the background.

A pedestrian counter can be installed in the form of a combined bicycle and pedestrian counting unit at site where both pedestrian and bicycle counts are needed, though it can be standalone.

On a shared path, a combined bicycle and pedestrian counting unit collects bicycle and pedestrian counts. The PIR sensor shall be mounted above the centre line of the path to create a detection zone to cover the pedestrian and cyclist traffic in both directions. The PIR sensor shall be placed right above the piezo-piezo bicycle sensors. In this setup, the combined bicycle and pedestrian counting unit should accurately report the true count of pedestrians by excluding cyclists who are also detected by the PIR sensor. For dimensions and placement details of the PIR sensor refer to SD1929 *ITS – Bicycle and pedestrian counter*.

**Figure 9.3.2 – Typical configuration for combined bicycle / pedestrian counter (Top view and Side view)**



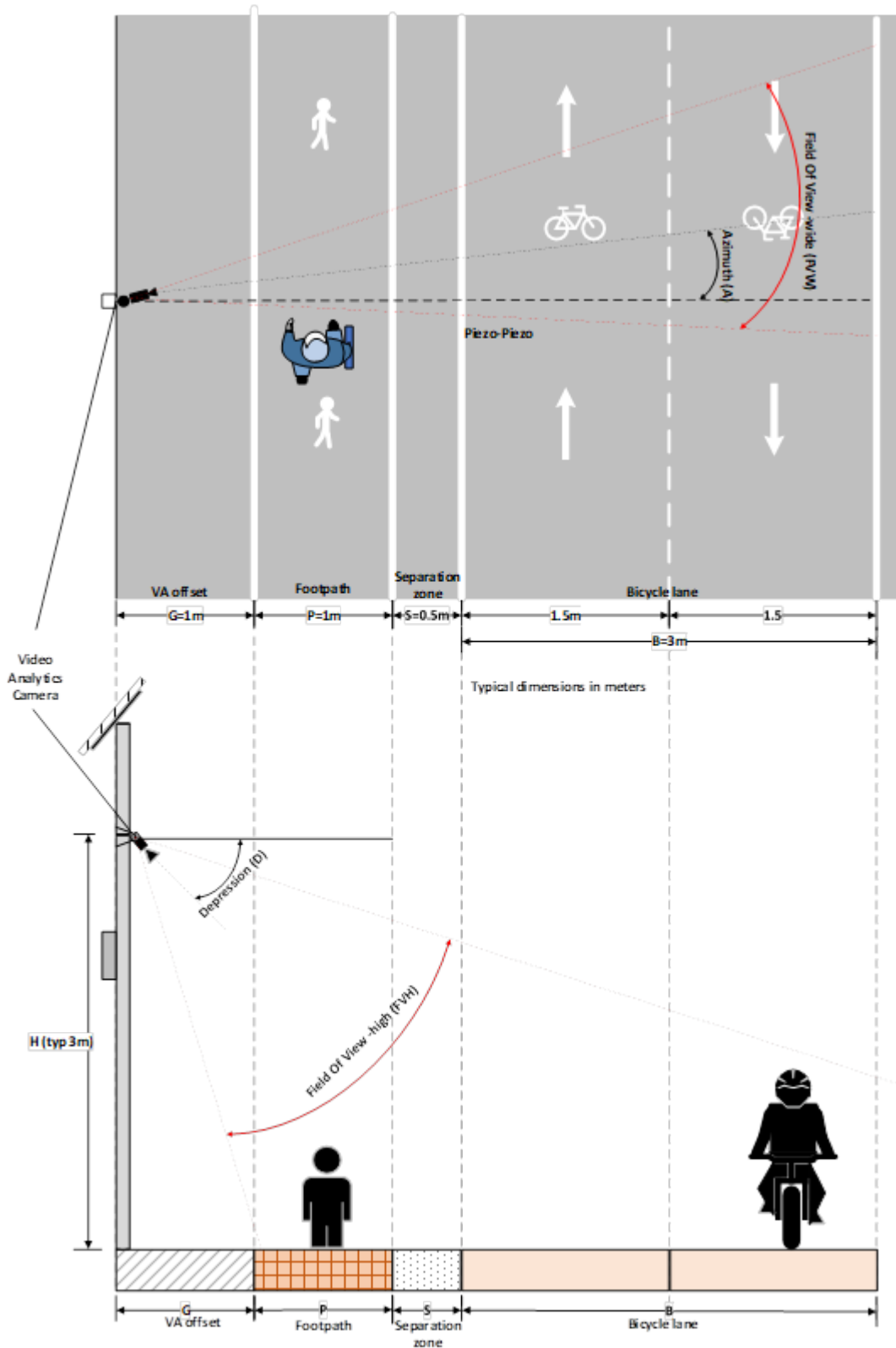
In sites where cyclist and pedestrian lanes are separated physically, the combined bicycle / pedestrian counting unit can be used as 2 independent counters, that is, one for bicycle counting and one for pedestrian counting.

### 9.3.3 Active transport classifier

Video analytics (VA) camera is used to classify active transport path users captured in video image frames. With pre-trained machine learning algorithms and site-specific enhancement learning, the camera can detect and identify bicycle, scooter, pedestrian or undetermined. A VA camera can be further extended to identify a wider range of active transport modes travelling on cycle path and footpath after its algorithms have been properly trained.

Active transport classifier can be installed on either shared path or separated path configuration. Figure 9.3.3 show a plan view and section view respectively of a typical site where cycle path and footpath are separated.

Figure 9.3.3 – Separated path (Top view) and (below) plan and section view



### 9.3.3.1 Design parameters

Designing an active transport classification site with VA cameras requires the designer to optimise a set of design parameters discussed in the following sub-sections, to achieve a best detection result.

Design parameters can be grouped under 5 categories, namely:

- Site geometry (Section 9.3.3.1.1)
- Path user attributes (Section 9.3.3.1.2)
- Detection zones (Section 9.3.3.1.3)
- VA camera placement (Section 9.3.3.1.4), and
- Camera type and associated features (Section 9.3.3.1.5).

#### 9.3.3.1.1 Site geometry

The general requirements for the detection of active travel defined in Section 9.1 apply to the selection of site for video analytics (VA).

Site geometry shall be evaluated for suitability for VA prior to selection. Geometric parameters considered for VA installation include:

- camera Offset
- footpath width
- separation zone width, where applicable
- bicycle lane width
- path curvature, where applicable, and
- longitudinal slope of path.

#### 9.3.3.1.2 Path user attributes

The designer should make the following assumptions regarding prospective path users, including pedestrians, scooter riders, and cyclists, under normal conditions:

- Maximum height of pedestrians, scooter riders, and cyclists (when seated on bicycles) is 1.75 m.
- Typical horizontal width for a pedestrian is 0.4 m.
- Typical horizontal width for a bicycle is 2 m.
- Cyclists generally avoid riding closer than 300 mm to the path edge when possible.
- Pedestrians tend to walk in the centre of the footpath if available. On a shared path, pedestrians keep to the left.
- Typical pedestrian speed is 4 kph, with a maximum speed of 16 kph.
- Typical cyclist speed is 20 kph, with a maximum speed of 40 kph.

#### 9.3.3.1.3 Detection zone

The detection zone is the area on the path where the VA camera has a full view of the entire path user, including any mobility device where present. It excludes the areas where only part of the path user is visible, and regions outside the path.

Whether on a shared path or separate path, the detection zone(s) should encompass pedestrians on the footpath and cyclists in both near and far cycle lane. The detection zone should generally meet the following criteria:

- The line of sight between the camera and its detection zone(s) must be unobstructed.
- The physical path area within the operating zone must be long enough for path users to traverse, allowing the VA camera sufficient time to capture the required image frames. The length of the path requirement is dependent of the features of the camera used (refer to Sections 9.3.3.1.4 and 9.3.3.1.5 below).
- The straight-line distance between the VA camera and any path user on the detection zone(s) should not exceed 30 m to avoid capturing objects too small to recognise.

#### **9.3.3.1.4 VA Camera placement**

The VA camera's setup parameters define the operating areas where it detects and classifies path users; these areas should be configured for maximum coverage.

General requirements for the placement of VA camera include:

- The VA camera must have a clear view of the entire bicycle, scooter, and pedestrian within the detection zone to accurately determine their presence.
- The VA camera should be oriented away from sun glare or any other direct light sources that could interfere with its functionality.
- Fine-tuning during installation, commissioning, and maintenance maybe required for optimal performance. If the mounting kit allows, the installer may rotate the camera about the viewing axis to optimise the field of view. Any adjustments to design parameters must be documented to support future maintenance activities.

The below define the considerations in defining key parameters in VA camera placement:

- **Location and Mounting height**
  - The VA camera should be mounted on the side closer to the footpath than to the cycle path as pedestrians generally travel slower than cyclists. This arrangement provides a longer detection distance for bicycles and reduces the risk by placing the mounting structure away from the higher-speed cycling path.
  - Avoid placing the VA camera in areas between the footpath and cycle path where the side view of the path user is minimal.
  - Installing the VA camera on a pole set farther from the path, can extend the detection zone coverage, though increased distance may reduce object size in images.
  - The VA camera shall be mounted at height to minimise vandalism while providing a clear view of users moving side-by-side. However, placing the VA camera too high may reduce image quality due to potential vibration and increased physical distance. A mounting height between 3.0 m and 6.5 m is recommended.

- **Depression**
  - Orientating the VA camera along the path's longitudinal axis, extends the length of the detection zone. However, aligning the VA camera more longitudinally, however, reduces the ability to distinguish between different kinds of path users, for example, pedestrian versus scooter rider. The distance between the detection zone and the camera becomes longer if the depression angle remains unchanged. A longer distance equates smaller object size in the image.
  - Marking a control point on the ground can assist installers aim the VA camera accurately during setup. The design plan should include the coordinates of the control point.
  - In general, the depression angle,  $D$ , *should not exceed 75°*.
- **Azimuth**
  - The VA camera should be aligned towards the side view of the objects as much as possible to distinguish between bicycles and scooters, with azimuth angle as close to 0° as possible.
  - The azimuth angle of VA camera *should not exceed 60°* to ensure sufficient side view of an object to be viewed.

#### 9.3.3.1.5 VA camera type and features

The type of VA camera used influences the target field of view (FoV) and the detection zone. A good VA camera may compensate for unfavourable site geometry resulting in optimal detection zone. The main considerations for a VA camera include:

- **Frame rate (fps)** – a minimum video frame rate 25 fps (frames per second)
- **Focal length (mm)** – The focal length of a camera is a major factor affecting the field of view
- **Camera lens format** – In selecting lens, the field of view of the camera shall be wide enough to create an optimal detection zone. However, wide angle lens incurs distortion that may cause complication for algorithms to identify the path user. For a given focal length, the field of view varies depending on the camera lens.
- **Resolution** – The target resolution for an image of a path user in a frame shall be 64 x 48 pixels or better. An image with more pixels makes it easier to distinguish between types, such as, cyclist, scooter rider, and pedestrian.
- **Night vision** – minimum level of illumination that the camera can adequately perform VA functions.

Table 9.3.3.1 lists the site design parameters applicable to a separated path configuration, using Figure 9.3.3 as a design reference plan. On a shared path, where pedestrians and cyclists share the same path, footpath width and cycle path-footpath separation parameters can be set to zero. Refer to Section 9.3.3.3.

### **9.3.3.2 Placement parameters on separated path**

Where cycle path and footpath are separated, the VA camera shall be placed on the footpath side to provide longer camera exposure distance for bicycles and scooters which travel faster than pedestrians.

Figure 9.3.3 shows a model arrangement for an Active Transport classification site on separated footpath / cycle path environment.

**Table 9.3.3 1 – List of Design Parameters**

Category	Parameter description	Parameter symbol (unit)	Range of Values	Typical Design Value (Example)	Remarks
Site Geometry	Camera offset from path	G (m)	0.5-2.0	1	Offset of the VA camera from nearest path edge (Refer to Figure 9.3.3)
	Footpath lane width	P (m)	0.5-2.0	1.5	Pedestrians are assumed travelling in the middle of the footpath. (Refer to Figure 9.3.3)
	Bicycle / footpath lane Separation	S (m)	0.5-1.0	0.5	Assume separated paths, that is, pedestrians are not allowed in cycle path. (Refer to Figure 9.3.3)
	Bicycle path lane width	B (m)	3.0-5.0	3	Path is assumed to be 2-lane bi-directional, and cyclists observe proper lane discipline by travelling in the middle of the corresponding lane. (Refer to Figure 9.3.3)
	Cycle path horizontal curvature radius	R (m)	>0 for camera outside the curve <0 for camera inside the curve $\infty$ for camera on straight path	$\infty$	Refer to Section 9.3.3.4 for illustrations of VA camera location relative to curvature.
	Path longitudinal slope (gradient)	SL (%)	0% (flat) – otherwise 3% (1:33) - 5% (1:20)	0	Must not exceed 5%

Category	Parameter description	Parameter symbol (unit)	Range of Values	Typical Design Value (Example)	Remarks
Path User attributes	Path user height (Pedestrians and cyclists)	(m)	1.0-2.0	1.75	Path user vertical height
	Pedestrian speed (includes running)	VP (m/s)	0.8-4.5	1	Typical walking speed is 1 m/s. Jogging speed, in some locations, may be as fast as 4.5 m/s.
	Bicycle / scooter speed	VB (m/s) or km/h	5-12.5 (18 km/h – 45 km/h)	8 (~30 km/h)	Avoid location where travel speed beyond 11.1 m/s (40 km/h)
Detection Zone *	Footpath coverage (effective footpath length in view)	CP (m)	0.5-4	0.81	The effective path length in which a typical pedestrian (1.75 m) walking in the middle of the footpath are seen in view. Path length requirement depends on camera performance.
	Near cycle lane coverage (effective near cycle lane length in view)	CBN (m)	3.0-10.0	5.56	The effective path length in which cyclists 1.75 m in height riding 300 mm offset from their left edge line in the near cycle lane are seen in view. Path length requirement depends on camera performance.
	Far cycle lane coverage (effective far cycle lane length in view)	CBF (m)	3.0-10.0	8.88	The effective path length in which cyclists 1.75 m in height riding 300 mm offset from their left edge line in the far cycle lane are seen in view. Path length requirement depends on camera performance.

Category	Parameter description	Parameter symbol (unit)	Range of Values	Typical Design Value (Example)	Remarks
VA Camera Placement	Azimuth angle (from camera toward cycle path)	A (°)	-60° to 60°	30	The camera Pan range - (Pan Angle)
	Depression angle	D (°)	15° to 75°	30	The camera vertical tilt range
	Camera offset from path	G (m)	0.5-2.0	1	Offset of the VA camera from nearest path edge (Refer to Figure 9.3.3)
	Mounting height	H (m)	3.0 - 6.5	3	Mounting height of VA camera up the pole
	Control point coordinate offset from VA pole	C_lat (m), C_lon (m)	2.0 - 10.0	4.5, 2.6	A point on site floor to aid aligning camera, measured as lateral and longitudinal offsets from camera pole along the path respectively.
Camera Features	Field of view (width x height)	FVW (°) x FVH (°)	Any range of values that capture the detection zone	65.4 x 46.4	The horizontal and vertical angles determining the field of view for the VA camera. (Refer to Figure 9.3.3)
	Frame rate	FR (fps)	>=25 fps	25	Minimum departmental requirement for frame rates in frames per second (fps)

### 9.3.3.3 Placement parameters on shared path

On a shared path where cyclists, scooter riders and pedestrians share the same physical space, the VA camera shall be placed on the side that provides the best visual quality. Generally, the side having minimum amount of sun glare is preferred.

Other factors to consider when selecting the optimal location to install VA camera include level of risk of vandalism and availability of sufficient solar-generated power.

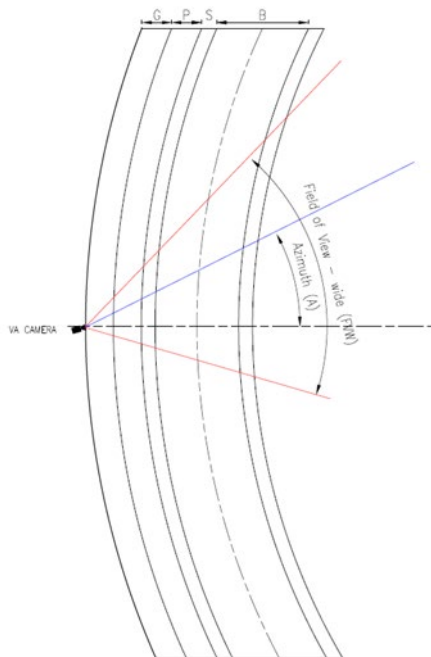
The model depicted by Figure 9.3.3 can represent a site on shared path by setting the 2 parameters, Footpath separation (S) and Footpath width (P), to zero.

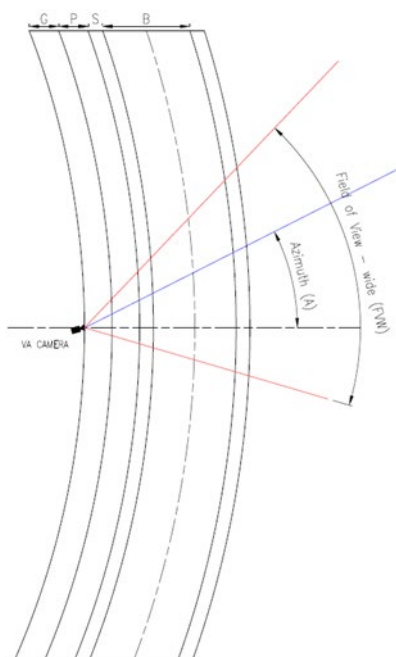
### 9.3.3.4 Site on curve path

It is advisable to install a VA camera on a straight path. However, if a site must be installed on a curvy path, then the horizontal curvature radius of the path is recommended to be greater than 10 times the distance from the VA camera pole to the median of the cycle path.

Installing a VA camera on the outside of a curvy path is equivalent to increasing the azimuth angle reducing the side view to the object. Refer to Figure 9.3.3.4(a). Whereas if a VA camera is installed in the inside of a curve, the detection zone is shortened compared to a straight path. Refer to Figure 9.3.3.4(b).

**Figure 9.3.3.4(a) – VA camera installed at the outside of a curvy path**



**Figure 9.3.3.4(b) – VA camera installed in the inside of a curvy path**

#### **9.4 Sensor installation for active transport counter/classifier (ATCC) site**

##### **9.4.1 Numbering of sensors**

The numbering sequence of ATCC sensors shall be as detailed in Section 7.4.1.

##### **9.4.2 Pneumatic tube installation**

The installation of pneumatic tubes for ATCC shall be in accordance with Section 7.4.2.

##### **9.4.3 Piezoelectric sensor installation**

The installation of pneumatic tubes for ATCC shall be in accordance with Section 7.4.4.

##### **9.4.4 Passive infrared sensor installation**

A PIR sensor at a combined bicycle and pedestrian counting site detects traffic in both travelling directions and, therefore, requires only one PIR sensor at site.

A PIR sensor shall be fixed at 4.6 m above the centre line of the path to create a detection zone to cover traffic in both directions. Refer to Section 9.3.2.

For shared path, PIR sensor installation shall be in accordance with Section A of SD1929 *ITS – Bicycle and pedestrian counter*. The counting of pedestrian shall be adjusted to avoid error on double counting cyclists as pedestrians.

For separated path, the PIR sensor shall be mounted similarly to shared path but positioned directly above the footpath to detect pedestrian traffic only.

**WARNING:** A PIR sensor shall not be installed within 10 m of any metallic pit lid or any object which has a thermal characteristic significantly different from that of the background.

### **9.4.5 Video analytics camera installation**

Unless specified by the manufacturer, a VA camera, should be mounted at height. This typically requires a mounting pole, enclosure, and cabling. Refer to SD1930 *ITS – Video analytics active transport classifier*. The VA camera must be properly aligned to meet the design objectives.

#### **9.4.5.1 Mounting pole**

The VA camera shall be mounted high enough to minimise vandalism but not too high to compromise system performance due to distorted object image or reduced object pixels in the image. Refer to Section 9.3.3.1.4. The mounting structure in its simplest form can be a pole. Should a site require a mounting height over 4.5 m, a swing pole should be considered for the convenience of maintenance.

The requirement and installation of any mounting structure shall comply with relevant departmental technical documents, including specifications, standard drawings, and guidelines.

#### **9.4.5.2 Enclosure**

VA cameras may require an enclosure to house supporting equipment, for example, edge processor, solar regulator, and battery. The enclosure shall comply with the requirements of MRTS226 *Telecommunications Field Cabinets* as a minimum.

#### **9.4.5.3 Cablings**

Cables must be concealed inside the mounting pole, conduits, or flexible conduits. Drip loops must be provided wherever applicable. Cabling entry points to the enclosure must be sealed and watertight.

#### **9.4.5.4 Installing and configuring VA camera**

The installation and configuration of a VA camera must meet the specified mounting height, azimuth angle, depression angle in the design drawings, as well as three coordinates of a control point which is a reference point on the floor to assist the installer to aim the camera. Refer to Section 9.3.3.1.

